

Making the railway system  
work better for society.

## Technical document

### *ELECTRONIC RESERVATION OF SEATS/BERTHS AND ELECTRONIC PRODUCTION OF TRAVEL DOCUMENTS - EXCHANGE OF MESSAGES – Annex 1*

*In the Document History table, version are identified as x.n where  
“x” is a correlative number assigned to an approved version when reaching a main milestones  
“n” is a correlative number assigned to draft versions, starting by 1. “n”=0 means version approved  
Information related to previous draft versions (i.e. 0.1, 0.2 etc.) shall be deleted from the table when a  
subsequent approved version is issued.*

#### *Document History*

<i>Version</i>	<i>Date</i>	<i>Comments</i>
1.4.5	15.12.2023	New annex A1

## Contents

1.	Overview.....	3
1.1.	Coding regulations.....	3
1.2.	List of abbreviations .....	4
1.3.	Characters used in the message elements.....	5
2.	Messages .....	6
2.1.	Binary messages (classic).....	6
2.1.1.	General .....	6
2.1.2.	Header .....	7
2.1.3.	"Application Text" prefix .....	8
2.1.4.	Reservation requests.....	9
2.1.5.	Partial cancellation requests .....	10
2.1.6.	Complete cancellation requests .....	12
2.1.7.	Synchronization request / reply .....	12
2.1.8.	Confirmation of reservation requests .....	13
2.1.9.	Confirmation of partial cancellation requests.....	16
2.1.10.	Confirmation of complete cancellation requests.....	20
2.1.11.	Replacement proposals, negative replies .....	21
2.1.12.	Correction messages - request/reply .....	22
2.1.13.	Distribution message description (DMD) .....	23
2.1.14.	Enquiry about availability and reply.....	24
3.	Coding the message elements "Reservation" .....	2
3.1.	Header .....	2
3.2.	Prefix "Application Text" .....	5
3.3.	Application text .....	7
4.	Exchange protocol at application level using MQ to MQ.....	45
4.1.	General .....	45
4.2.	Normal operation .....	46
4.3.	Defect in allocating system, before the reply can be sent .....	47
4.4.	Defect before the reply is received from the allocating system .....	49
4.5.	Defect in issuing system after receipt of reply from the allocating system.....	49
4.6.	The system is unable to use the confirmation received .....	50
4.7.	Extended error recovery in case of Time Out on Reservation .....	51
4.8.	Extended error recovery in case of Time Out on Cancellation .....	52
4.9.	Repeated requests on Cancellation.....	54
5.	Principal Binary Message Structure.....	55
5.1.	Definitions .....	56
5.1.1.	Element.....	56
5.1.2.	Group of elements.....	56
5.1.3.	Phrase .....	56
5.1.4.	Message.....	56
5.2.	Messages .....	57

5.2.1.	Identification of messages.....	57
5.2.2.	Phrase identifier .....	57
5.2.3.	Identity of the phrase.....	57
5.2.4.	Version code .....	57
5.2.5.	Topographical label .....	57
5.2.6.	Phrase structure .....	58
5.3.	Example of phrases to be transmitted .....	58
5.3.1.	Phrases with compulsory and optional elements .....	58
5.3.2.	Phrases which contain compulsory elements only .....	60
5.3.3.	Phrases which contain optional elements only.....	60
5.4.	Reservation messages .....	61
5.4.1.	Structure.....	61
5.4.2.	Header phrase.....	61
5.4.3.	Application text phrase .....	61
5.4.4.	Sequencing between the Application text phrases .....	62
5.4.5.	Sequencing request/negative reply or alternative proposal .....	63
5.4.6.	Sequencing request/global negative reply .....	64
5.5.	Extended reservation messages 918E .....	65
5.5.1.	Identification of 918E messages.....	65
5.5.2.	Sequencing of application texts in 918 <sup>E</sup> messages.....	65

**Application:**

With effect from **08 March 2012**.

All actors of the European Union falling under the provisions of the TAP TSI.

**1. Overview****1.1. Coding regulations**

The elements described below are always of the same length. If the information is shorter than the field length, the following rules apply:

**Numerical coding (N):**

The information is entered justified on the right and the left of the field is filled with zeros.

Optional elements must be coded in such a way that no elements occur containing only zeros.

**Alphanumerical coding (A) and alphanumerical coding with special character (C):**

The information is entered justified on the left and the right of the field is filled with "blanks" ("spaces").

Optional elements must be coded in such a way that no elements occur containing only blanks.

**1.2. List of abbreviations**

Heading	ACC	Confirmation
	AP	Partial cancellation
	ASS	Seats in trains
	AT	Complete cancellation
	AUB	Car on ferry
	AUT	Car-carrying train
	CC	Couchettes in trains
	D	Specific seat
	DEM	Request
	DMD	Distribution Message Descriptor
	L+C	Length and code
	MNS	Non-solicited message
	MR	Correction
	N	Normal seat request
	PB	Passengers on ferry
	PRM	Passenger with reduced mobility
	PRP	Replacement proposal for other service
	PRR	Replacement proposal for other RS
	PRT	Replacement proposal for other train/other ferry
	REP	Reply
	RES	Reservation
	RN	Negative reply
	RP	Seats with at-seat meal in trains
	V	Adjacent seat
	VL	Berths in trains
	VR	Meal in restaurant car
Column code	N	Numerical character
	A	Alphanumerical character
	C	Printable character (A + special character)
Table content	O	Obligatory element
	1 – 32	Optional element (serial number in topographical label)
	-	Element not existent

### 1.3. Characters used in the message elements

Coding	Designation	ASCII-Code
!	Exclamation sign	X'21'
"	Quote marks	X'22'
#	Hash	X'23'
\$	Dollar sign	X'24'
%	Percent	X'25'
&	Ampersand	X'26'
'	Apostrophe	X'27'
(	Left parenthesis	X'28'
)	Right parenthesis	X'29'
*	Asterisk	X'2A'
+	Plus	X'2B'
,	Comma	X'2C'
-	Minus	X'2D'
.	Dot	X'2E'
/	Slash	X'2F'
:	Colon	X'3A'
;	Semicolon	X'3B'
<	Less than	X'3C'
=	Equal to	X'3D'
>	More than	X'3E'
?	Question mark	X'3F'
@	e-mail 'at'	X'40'

## 2. Messages

### 2.1. Binary messages (classic)

#### 2.1.1. General

The application "Seat reservation" concerns messages relating to:

- › Reservation in trains,
- › Availability information,

The necessary information elements are described in this Technical Document.

### 2.1.2. Header

The obligatory header for all messages prepared in accordance with this Technical Document is:

Number	Element	L+C
1	Receiving reservation system	2 N O
2	Sending reservation system	2 N O
3	Dialogue number	5 N O
4	Number of the day in the year	3 N O
5	Type of message	1 N O
6	Type of service	1 N O
7	Number of the requesting terminal	7 A O
8	Type of requesting office or type of protocol message	1 N O
9	Number of the application version	1 N O
10	Field at disposal	2A O
11	Test	1 N O



### 2.1.3. "Application Text" prefix

This is obligatory before each application text.

An application text may be: a request, a confirmation, a negative reply, a replacement proposal, a correction message or a listing message.

Number	Element	L+C
15	Service	2NO
16	Type of request or reply	1 N O
17	Serial number	2 N O
18 <sup>a</sup>	Type of text	2NO

a. Element 18 is only available when, in the header, element 6 has the value 8 = 918<sup>E</sup> - message.

In these cases, at least 2 application texts are available in the message, the first of which is a DMD (see point 2.14 - page **Error! Bookmark not defined.**).

In case of a 918<sup>E</sup> – message with a DMD and negative replies the type of request or reply of the DMD should also be value 8 (=negative reply).

## 2.1.4. Reservation requests

No	Element	L+C	ASS			CC			VL			RP			AU T	VR
			N	D	V	N	D	V	N	D	V	N	D	V		
20A	Train number	5A	0	0	0	0	0	0	0	0	0	0	0	0	0	0
21A	Departure date	4N	0	0	0	0	0	0	0	0	0	0	0	0	0	0
22A	Boarding station	7N	0	0	0	0	0	0	0	0	0	0	0	0	0	0
22B	Destination station	7N	0	0	0	0	0	0	0	0	0	0	0	0	0	0
23A	Number of seats	2N	0	-	0	0	-	0	0	-	0	0	-	0	-	-
24	Class	1A	0	0	0	0	0	0	0	-	-	0	0	0	-	-
25A	Type and number of berths	12N	-	-	-	-	-	-	0	0	0	-	-	-	-	-
26A	Type and number of meals	6N	-	-	-	-	-	-	-	-	-	0	0	0	-	0
27	Coach number	3A	-	0	0	-	0	0	-	0	0	-	0	0	-	-
28A	Number of particular seat	3A	-	0	-	-	0	-	-	0	-	-	0	-	-	-
28B	Number of a reference seat	3A	-	-	0	-	-	0	-	-	0	-	-	0	-	-
29A	Vehicle category	1 N	-	-	-	-	-	-	-	-	-	-	-	-	0	-
30	Vehicle registration	10C	-	-	-	-	-	-	-	-	-	-	-	-	0	-
31	Number and ages of the passengers	8N	-	-	-	-	-	-	-	-	-	-	-	-	0	-
32	Journey number	1 N	-	-	-	-	-	-	-	-	-	-	-	-	0	-
33	Journey code	1 N	-	-	-	-	-	-	-	-	-	-	-	-	0	-
35	Smoking/non- smoking	1 N	1	-	-	1	-	-	-	-	-	1	-	-	-	-
36	Position of seat	4 N	2	-	-	2	-	-	1	-	-	2	-	-	-	-
37	Compartment request	6 N	3	-	-	3	-	-	2	-	-	3	-	-	-	-
38A	Position of compartment! request	1 N	a	-	-	-	-	-	3	-	-	a	-	-	-	-
39	Compartment with connecting door	1 N	-	-	-	-	-	-	4	-	-	-	-	-	-	-
40	Compartment characteristics <sup>b</sup>	1 N	-	-	-	-	-	-	5	1	-	-	-	-	-	-
41B	Time of lunch	4N	-	-	-	-	-	-	-	-	-	4	1	1	-	1
41C	Time of dinner	4N	-	-	-	-	-	-	-	-	-	5	2	2	-	2
42A	Tariff 1	9N	4	1	1	4	1	1	6	2	1	6	3	3	a	-
42B	Tariff 2	9N	5	-	2	5	-	2	7	-	2	7	-	4	-	-
43	Individual reservation tickets requested	1 N	6	-	3	6	-	3	8	-	3	8	-	5	-	3
44	Another train acceptable	1 N	7	-	-	7	-	-	9	-	-	9	-	-	1	-
45A	Trailer category	1 N	-	-	-	-	-	-	-	-	-	-	-	-	2	-
29B	Boat category	1 N	-	-	-	-	-	-	-	-	-	-	-	-	3	-

No	Element	L+C	ASS			CC			VL			RP			AUT	VR
			N	D	V	N	D	V	N	D	V	N	D	V		
46	Number of dogs	1 N	-	-	-	-	-	-	-	-	-	-	-	-	4	-
47A	Requesting reservation system	2N	8	2	4	8	2	4	10	3	4	10	4	6	-	4
69	Vehicle transport price only	1 N	-	-	-	-	-	-	-	-	-	-	-	-	5	-
70	Loading lower deck	1 N	-	-	-	-	-	-	-	-	-	-	-	-	6	-
71	Height	3N	-	-	-	-	-	-	-	-	-	-	-	-	7	-
76	Code of the travel agent's organisation	5 N	9	3	5	9	3	5	11	4	5	11	5	7	8	5
77	Passenger with vehicle	1 N	10	4	6	10	4	6	12	5	6	12	6	8	-	-
38A	Position of compartment request	1 N	11	-	-	-	-	-	a	-	-	13	-	-	-	-
42A	Tariff 1	9N	a	a	a	a		a	a	a	a	a	a	a	9	-
80	Country code of requesting terminal	2A	12	5	7	11	5	7	13	6	7	14	7	9	10	6
90	FulfillmentMedium	3 A	13	6	8	12	6	8	14	7	8	15	8	10	11	-
91	PassengerData	400 C	14	7	9	13	7	9	15	8	9	16	9	11	12	-
92	PassengerDataExtension	1000 C	15	8	10	14	8	10	16	9	10	17	10	12	13	-
96	ExchangeReference	24 A	16	9	11	15	9	11	17	10	11	18	11	13	14	-
93	ListOfPassengerIdsCancelled	70 A	17	10	12	16	10	12	18	11	12	19	12	14	15	-
97	Number of coaches accepted (default value 1)	1 N	18	11	13	17	11	13	19	12	13	20	13	15	16	-

- a This element appears several times in the Table but only once in the message.
- b Appears only if the number of seats does not correspond to a number of complete compartments.

### 2.1.5. Partial cancellation requests

No.	Element	L+C	ASS	CC	VL	RP	AUT	VR
20A	Train number	5 A	O	O	O	O	O	O
21A	Departure date	4 N	O	O	O	O	O	O
23A	Number of seats	2 N	O	O	O	O	-	-
25A	Type and number of berths	12N	-	-	O	-	-	-
26A	Type and number of meals	6 N	-	-	-	O	-	O
34A	Reference number of reservation ticket to be cancelled	12 N	O	O	O	O	O	O

36	Position of seat	4 N	1	1	1	1	-	-
38A	Position of compartment/request	1 N	A	-	2	a	-	-
40	Compartment characteristics <sup>b</sup>	1 N	-	-	3	-	-	-
42A	Tariff 1	9N	2	2	4	2	-	-
42B	Tariff 2	9N	3	3	5	3	-	-
47A	Requesting reservation system	2 N	4	4	6	4	-	1
74	Reason for cancellation	2 N	5	5	7	5	-	-
76	Code of the travel agent's organisation	5 N	6	6	8	6	-	2
38A	Position of compartment/request	1 N	7	-	a	7	-	-
80	Country code of requesting terminal	2 A	8	7	9	8	2	3
90	FulfillmentMedium	3 A	9	8	10	9		
91	PassengerData	400 C	10	11	11	10		
92	PassengerDataExtension	1000 C	11	12	12	13		
93	ListOfCanceledPassengerIds	70 A	12	13	14			

In case the personal data are incomplete the booking will be rejected with reply code 003.

- a. This element appears several times in the Table but only once in the message.
- b. Appears only if the number of seats does not correspond to a number of complete compartments.

**2.1.6. Complete cancellation requests**

No.	Element	L+C	ASS	CC	VL	RP	AUT	VR
20A	Train number	5 A	0	0	0	0	0	0
21A	Departure date	4 N	0	0	0	0	0	0
34A	Reference number of reservation ticket to be cancelled	12 N	0	0	0	0	0	0
47A	Requesting reservation system	2 N	1	1	1	1	-	1
74	Reason for cancellation	2 N	2	2	2	2	1	-
76	Code of the travel agent's organisation	5 N	3	3	3	3	2	2
80	Country code of requesting terminal	2 A	4	4	4	4	3	3

**2.1.7. Synchronization request / reply**

The synchronization request and reply message include the message header only. They do not contain an application text.

The synchronization message is used in case of lost reservation dialogs according to the error scenarios defined in Appendix **Error! Reference source not found..**

The dialog number (Element 3) contains the dialog number of the lost dialog as described in section **Error! Reference source not found..**

## 2.1.8. Confirmation of reservation requests

No.	Element	L+C	ASS	CC	VL	RP	AUT	VR
20A	Train number	5 A	O	O	O	O	O	O
48	Train category	2 N	O	O	O	O	O	-
21A	Departure date	4 N	O	O	O	O	O	O
41A	Departure time	4 N	O	O	O	O	-	-
49A	Name of boarding station	30 C	O	O	O	O	-	O
49B	Name of destination station	30 C	O	O	O	O	-	O
34B	Reference number of accommodations	12 N	O	O	O	O	O	-
34C	Reference number for breakfast	12 N	-	-	-	O	-	O
34D	Reference number for lunch	12 N	-	-	-	O	-	O
34E	Reference number for dinner	12 N	-	-	-	O	-	O
27	Coach number	3 A	O	O	O	O	-	-
23A	Number of seats	2 N	O	O	O	O	-	-
50A	Accommodation allocated	32 C	O	O	O	O	-	-
24	Class	1A	O	O	O	O	-	-
51	Type of compartment allocated	6 N	O	O	O	O	-	-
26A	Type and number of meals	6 N	-	-	-	O	-	O
41 B	Time of lunch	4 N	-	-	-	O	-	O
41 C	Time of dinner	4 N	-	-	-	O	-	O
52A	Price (reservation charge, supplement)	7 N	O	O	O	O	O	-
52B	Price of breakfast	7 N	-	-	-	O	-	O
52C	Price of lunch	7N	-	-	-	O	-	O
52D	Price of dinner	7 N	-	-	-	O	-	O
49C	Name of loading station	30 C	-	-	-	-	O	-
21C	Loading date	4N	-	-	-	-	O	-
41D	Start of loading period	4 N	-	-	-	-	O	-
41 E	End of loading period	4 N	-	-	-	-	O	-
49D	Name of unloading station	30 C	-	-	-	-	O	-
21D	Unloading date	4N	-	-	-	-	O	-
41 F	Start of unloading period	4 N	-	-	-	-	O	-
41G	End of unloading period	4 N	-	-	-	-	O	-
30	Vehicle registration	10C	-	-	-	-	O	-

No.	Element	L+C	ASS	CC	VL	RP	AUT	VR
53	Number of the entry in loading list	3 N	-	-	-	-	0	-
32	Journey number	1 N	-	-	-	-	0	-
29A	Vehicle category	1 N	-	-	-	-	0	-
54	Price calculation code	1 N	-	-	-	-	0	-
55	Number of passengers	4 N	-	-	-	-	0	-
65	Undertaking providing the service	1 N	-	-	0	-	-	-
56	Change of train/date	1 N	1	1	1	1	1	1
57	Change of station	1 N	2	2	2	2	2	2
41 H	Arrival time	4 N	3	3	3	3	-	-
50B	Additional accommodation allocated	32 C	4	4	4	4	-	-
39	Compartment with connecting door	1 N	-	-	5	-	-	-
21 E	Date of breakfast	4 N	-	-	-	5	-	3
21F	Date of lunch	4N	-	-	-	6	-	4
21G	Date of dinner	4N	-	-	-	7	-	5
58	Number of supplements	2 N	5	5	6	8	-	-
59	Type of supplements	1 N	6	6	7	9	-	-
42A	Tariff 1	9 N	7	7	8	10	-	-
42B	Tariff 2	9 N	8	8	9	11	-	-
60	Number of night sectors	1 N	-	9	-	-	-	-
45A	Trailer category	1 N	-	-	-	-	3	-
46	Number of dogs	1 N	-	-	-	-	4	-
49E	Name of boarding station (start of journey)	30 C	-	-	-	-	5	-
49F	Name of destination station (end of journey)	30 C	-	-	-	-	6	-
29B	Boart category	1 N	-	-	-	-	7	-
41I	Start of additional loading period	4 N	-	-	-	-	8	-
41J	End of additional loading period	4 N	-	-	-	-	9	-
41K	Start of additional unloading period	4 N	-	-	-	-	10	-
41 L	End of additional unloading period	4 N	-	-	-	-	11	-
23C	Number of overbooked seats	2 N	9	-	-	-	-	-

No.	Element	L+C	ASS	CC	VL	RP	AUT	VR
47A	Requesting reservation system	2 N	10	10	10	12	-	-
66	Text for special offers	30 C	11	11	11	13	-	-
40	Compartment characteristics	1 N	-	-	12	-	-	-
70	Loading lower deck	1 N	-	-	-	-	12	-
71	Height	3N	-	-	-	-	13	-
67	Type of price	1 N	12	12	13	14	14	-
73A	Partial price 1	14N	13	13	14	15	-	-
73B	Partial price 2	14 N	14	14	15	16	-	-
73C	Partial price 3	14 N	15	15	16	17	-	-
21H	Arrival date	4N	16	16	17	18	15	-
77	Passenger with vehicle	1 N	17	17	18	19	-	-
38B	Position of compartment/allocation	1 N	18	-	19	20	-	-
79	List of carriers	36A	19	18	20	21	16	-
42A	Tariff 1	9N	a	a	a	a	17	-
81	Service brand information	40 C	20	19	21	22	18	-
86	Cancellation time limits	96 C	21	20	22	23	19	-
90	FulfillmentMedium	3 A	22	21	23	24	20	-
94	eTicketData	500 C	23	22	24	25	21	-
95	eTicketDataExtension	2000 C	24	23	25	26	22	-

a. This element appears several times in the Table but only once in the message



## 2.1.9. Confirmation of partial cancellation requests

No.	Element	L+C	ASS	CC	VL	RP	AUT	VR
20A	Train number	5 A	O	O	O	O	O	O
48	Train category	2 N	O	O	O	O	O	-
21A	Departure date	4 N	O	O	O	O	O	O
41A	Departure time	4 N	O	O	O	O	-	-
49A	Name of boarding station	30 C	O	O	O	O	-	O
49B	Name of destination station	30 C	O	O	O	O	-	O
34B	Reference number of accommodations	12 N	O	O	O	O	O	-
34C	Reference number for breakfast	12 N	-	-	-	O	-	O
34D	Reference number for lunch	12 N	-	-	-	O	-	O
34E	Reference number for dinner	12 N	-	-	-	O	-	O
27	Coach number	3 A	O	O	O	O	-	-
23A	Number of seats	2 N	O	O	O	O	-	-
50A	Accommodation allocated	32 C	O	O	O	O	-	-
24	Class	1A	O	O	O	O	-	-
51	Type of compartment allocated	6 N	O	O	O	O	-	-
26A	Type and number of meals	6 N	-	-	-	O	-	O
41 B	Time of lunch	4 N	-	-	-	O	-	O
41 C	Time of dinner	4 N	-	-	-	O	-	O
52A	Price (reservation charge, supplement)	7 N	O	O	O	O	O	-
52B	Price of breakfast	7 N	-	-	-	O	-	O
52C	Price of lunch	7N	-	-	-	O	-	O
52D	Price of dinner	7 N	-	-	-	O	-	O
49C	Name of loading station	30 C	-	-	-	-	O	-
21C	Loading date	4N	-	-	-	-	O	-
41D	Start of loading period	4 N	-	-	-	-	O	-
41 E	End of loading period	4 N	-	-	-	-	O	-
49D	Name of unloading station	30 C	-	-	-	-	O	-
21D	Unloading date	4N	-	-	-	-	O	-
41 F	Start of unloading period	4 N	-	-	-	-	O	-
41G	End of unloading period	4 N	-	-	-	-	O	-
30	Vehicle registration	10C	-	-	-	-	O	-

No.	Element	L+C	ASS	CC	VL	RP	AUT	VR
53	Number of the entry in loading list	3 N	-	-	-	-	0	-
32	Journey number	1 N	-	-	-	-	0	-
29A	Vehicle category	1 N	-	-	-	-	0	-
54	Price calculation code	1 N	-	-	-	-	0	-
55	Number of passengers	4 N	-	-	-	-	0	-
34F	Reference number of cancelled reservation	12 N	0	0	0	0	0	0
52E	Amount of refund	7 N	0	0	0	0	0	0
23B	Number of cancelled seats	2 N	0	0	-	0	-	-
25B	Type and number of cancelled berths	12 N	-	-	0	-	-	-
26B	Types and number of cancelled meals	6 N	-	-	-	0	-	0
45B	Category of the cancelled trailer	1 N	-	-	-	-	0	-
64	Date of the original reservation	5 N	0	0	0	0	0	0
65	Undertaking providing the service	1 N	-	-	0	-	-	-
57	Change of station	1 N	1	1	1	1	-	1
41 H	Arrival time	4 N	2	2	2	2	-	-
50B	Additional accommodation allocated	32 C	3	3	3	3	-	-
39	Compartment with connecting door	1 N	-	-	4	-	-	-
21 E	Date of breakfast	4 N	-	-	-	4	-	2
21F	Date of lunch	4N	-	-	-	5	-	3
21G	Date of dinner	4N	-	-	-	6	-	4
58	Number of supplements	2 N	4	4	5	7	-	-
59	Type of supplements	1 N	5	5	6	8	-	-
42A	Tariff 1	9 N	6	6	7	9	a	-
42B	Tariff 2	9 N	7	7	8	10	-	-
60	Number of night sectors	1 N	-	8	-	-	-	-
46	Number of dogs	1 N	-	-	-	-	1	-
49E	Name of boarding station (start of journey)	30 C	-	-	-	-	2	-
49F	Name of destination station (end of journey)	30 C	-	-	-	-	3	-

No.	Element	L+C	ASS	CC	VL	RP	AUT	VR
29B	Boat category	1 N	-	-	-	-	4	-
41I	Start of additional loading period	4 N	-	-	-	-	5	-
41J	End of additional loading period	4 N	-	-	-	-	6	-
41K	Start of additional unloading period	4 N	-	-	-	-	7	-
41 L	End of additional unloading period	4 N	-	-	-	-	8	-
23C	Number of overbooked seats	2 N	8	-	-	-	-	-
47A	Requesting reservation system	2 N	9	9	9	11	-	-
66	Text for special offers	30 C	10	10	10	12	-	-
40	Compartment characteristics	1 N	-	-	11	-	-	-
70	Loading lower deck	1 N	-	-	-	-	9	-
71	Height	3N	-	-	-	-	10	-
67	Type of price	1 N	11	11	12	13	11	-
73A	Partial price 1	14N	12	12	13	14	-	-
73B	Partial price 2	14 N	13	13	14	15	-	-
73C	Partial price 3	14 N	14	14	15	16	-	-
73D	Partial price 4	14 N	15	15	16	17	-	-
73E	Partial price 5	14N	16	16	17	18	-	-
73F	Partial price 6	14N	17	17	18	19	-	-
75	Mark of changed price	1 N	18	18	19	20	-	-
21 H	Arrival date	4 N	19	19	20	21	-	-
77	Passenger with vehicle	1 N	20	20	21	22	-	-
38B	Position of compartment/allocation	1 N	21	-	22	23	-	-
79	List of carriers	36A	22	21	23	24	12	-
42A	Tariff 1	9N	a	a	a	a	13	-
81	Service brand information	40 C	23	22	24	25	14	-
86	Cancellation time limits	96 C	24	23	25	26	15	-
88	Original Cancellation Date	6 N	25	24	26	27	16	-
89	Requesting system of original cancellation	2 N	26	25	27	28	17	-
90	FulfillmentMedium	3 A	27	26	28	29	18	

No.	Element	L+C	ASS	CC	VL	RP	AUT	VR
94	eTicketData	500 C	28	27	29	30	19	
95	eTicketDataExtension	2000 C	29	28	30	31	20	

a. This element appears several times in the table but only once in the message.

## 2.1.10. Confirmation of complete cancellation requests

No.	Element	L+C	ASS	CC	VL	RP	AUT	VR
20A	Train number	5 A	0	0	0	0	0	0
21A	Departure date	4 N	0	0	0	0	0	0
41A	Departure time	4 N	0	0	0	0	-	-
24	Class	1A	0	0	0	0	-	-
34F	Reference number of cancelled reservation ticket	12 N	0	0	0	0	0	0
52E	Amount of refund	7 N	0	0	0	0	0	0
23B	Number of cancelled seats	2 N	0	0	-	0	-	-
25B	Type and number of cancelled berths	12 N	-	-	0	-	-	-
26B	Type and number of cancelled meals	6 N	-	-	-	0	-	0
29C	Category of cancelled vehicle	1 N	-	-	-	-	0	-
64	Date of the original reservation	5 N	0	0	0	0	0	0
65	Undertaking providing the service	1 N	-	-	0	-	-	-
45B	Category of the cancelled trailer	1 N	-	-	-	-	1	-
29D	Category of cancelled boat	1 N	-	-	-	-	2	-
60	Number of night sectors	1 N	-	1	-	-	-	-
42A	Tariff 1	9N	1	2	1	1	-	-
42B	Tariff 2	9N	2	3	2	2	-	-
58	Number of supplements	2 N	3	4	3	3	-	-
59	Type of supplements	1 N	4	5	4	4	-	-
47A	Requesting reservation system	2 N	5	6	5	5	-	-
67	Type of price	1 N	6	7	6	6	3	-
73D	Partial price 4	14 N	7	8	7	7	-	-
73E	Partial price 5	14 N	8	9	8	8	-	-
73F	Partial price 6	14 N	9	10	9	9	-	-
75	Mark of changed price	1 N	10	11	10	10	4	-
88	Original Cancellation Date	6 N	11	12	11	11	5	1
89	Requesting system of original cancellation	2 N	12	13	12	12	6	2

*2.1.11. Replacement proposals, negative replies*

No.	Element	L+C	PRP	PRT	PRR	RN
47B	Reservation system with further seat offer	2 N	-	-	0	-
20A	Train number	5 A	-	0	1	-
62	Available services	9 A	0	1	-	-
63	Reply code	3N	-	-	-	0
21A	Departure date	4 N	-	2	-	-
41A	Departure time	4 N	-	3	-	-
41 H	Arrival time	4 N	-	4	-	-
48	Train category	2 N	-	5	-	-
61	Request number	2 N	1	6	2	1
81	Service brand information	40 C	-	7	-	-

**2.1.12. Correction messages - request/reply****Principles**

1. The dialogue number allocated by the sender is quoted by the allocating system in the reply. The number differs from the message which initiated the cancellation request.
2. If a reply is not received to a cancellation request, a synchronisation message follows.
3. A correction message is not necessary for a complete cancellation.
4. The correction message may contain several application texts if the reply originally received contained several confirmations.

No.	Element	L+C	ASS	CC	VL	RP	AUT	VR
68	Number of the original dialogue	5 N	O	O	O	O	O	O
20A	Train number	5 A	O	O	O	O	O	O
21A	Departure date	4 N	O	O	O	O	O	O
23A	Number of seats	2 N	O	O	O	O	-	-
34B	Reference number of accommodations	12 N	O	O	O	O	O	-
34C	Reference number for breakfast	12 N	-	-	-	O	-	O
34D	Reference number for lunch	12 N	-	-	-	O	-	O
34E	Reference number for dinner	12 N	-	-	-	O	-	O
52A	Price (reservation charge, supplement)	7 N	O	O	O	O	O	-
52B	Price of breakfast	7 N	-	-	-	O	-	O
52C	Price of lunch	7N	-	-	-	O	-	O
52D	Price of dinner	7 N	-	-	-	O	-	O
47A	Requesting reservation system	2 N	O	O	O	O	-	-
80	Country code of requesting terminal	2 A	1	1	1	1	1	1

2.1.13. *Distribution message description (DMD)*

No.	Element	L+C	Request	Confirmation
22C	Starting station	7 N	0	0
22D	Final station	7N	0	0
22E	Return station	7 N	0	0
33	Journey code	1 N	0	0
314	Product code	10A	0	0
307	not used	12A	1	1
306	not used	30 C	2	2
304	not used	1 N	3	3
305	Currency code	3 A	4	4
310	not used	4N	5	5
311	Number of combined messages	2 N	6	6
66A	Notices	30 C	7	7

In case of a 918<sup>E</sup> – message with a DMD and negative replies the type of request or reply of the DMD application text prefix should also be value 8 (=negative reply).



## 2.1.14. Enquiry about availability and reply

No.	Element	L+C	Request	Confirmation
20A	Train number	5 A	0	0
22A	Boarding station	7 N	0	-
22B	Destination station	7 N	0	-
49A	Name of boarding station	30 C	-	0
49B	Name of destination station	30 C	-	0
326A	Departure date	6N	0	0
41A	Departure time	4 N	0	0
326B	Arrival date	6 N	-	0
41 H	Arrival time	4 N	-	0
318A	Service code 1	2A	0	0
300A	Availability information 1	8A	-	0
321	Text groups - identifier	2 N	-	1
314	Product code	10A	-	2
317C	Request area	1 N	1	-
48	Train category	2 N	2	3
37	Compartment request	6 N	3	-
51	Type of compartment allocated	6 N	-	4
322A	Conditions of use	3 N	-	5
318B	Service code 2	2 A	4	-
318C	Service code 3	2 A	5	-
308A	Service Level – Tariff Link 1	4A	6	-
308B	Service Level – Tariff Link 2	4 A	7	-
308C	Service Level – Tariff Link 3	4 A	8	-
300B	Availability information 2	8A	-	6
300C	Availability information 3	8A	-	7
300D	Availability information 4	8A	-	8
300E	Availability information 5	8A	-	9
300F	Availability information 6	8A	-	10
300G	Availability information 7	8 A	-	11

328	Tariff table	13 A	-	12
329	Tariff table 2	26 A	-	13
330	Tariff table 4	52 A	-	14
331	Tariff table 8	104 A	-	15
332	Tariff table 16	208 A	-	16
82	Service brand code	4 N	9	
81	Service brand information	40 C		17
27	Coach number <sup>1</sup>	3 A	10	18
340	Price Table	<b>Error! Reference not found.</b>		19
341	Price Table2	<b>2 * Error! Reference not found.</b>		20
342	Price Table4	<b>4 * Error! Reference not found.</b>		21
343	Price Table8	<b>8 * Error! Reference not found.</b>		22
344	Price Table16	<b>16 * Error! Reference not found.</b>		23
345	Price Table32	<b>32 * Error! Reference not found.</b>		24
346	Price Table64	<b>64 * Error! Reference not found.</b>		25
2	Allocating Reservation system	<b>2 N Error! Reference not found.</b>		26
351	Include Price Flag	1 N	11	
352	Tariff Selection	32 A	12	

If the requestor wants to get price information the Include Price Flag must be set.

The Price Tables include all information available in the Tariff Table elements as well, the Tariff Table elements therefore can be omitted if the Price Table elements are requested and sent.

The Elements Price Table, Allocating Railway, Include Price Flag and Tariff Selection are used to include prices in the availability message.

The elements Price Tables and Allocated Railway can be sent only if the prices are requested by sending the Include Price Flag.

<sup>1</sup> If the reply message include element 27 all information only belong to this coach.

### 3. Coding the message elements "Reservation"

#### 3.1. Header

##### 1 - Receiving reservation system

Length = 2, coding = numerical

See Code List B.5.1

##### 2 - Sending reservation system

(see element 1)

##### 3 - Dialogue number

Length = 5, coding = numerical

In the dialogue operation, the dialogue number is the only information which enables the reply received to be related to the request submitted. This number is given by the requesting reservation system. The reservation system addressed quotes the number in the reply.

##### 4 - Number of day in the year

Length = 3, coding = numerical

Within a year, the day on which the message is sent. In the response message the day is given by the allocating reservation system. (It is also the accounting date).

In case of a synchronization request the date must be the date of the initial reservation request. In the synchronization response message the day is given by the allocating reservation system.

##### 5 - Type of message

Length = 1, coding = numerical

See Code List B.5.5

##### 6 - Type of service

Length = 1, coding = numerical

See Code List B.5.6

The following table gives the possible combinations of the type of message and type of service elements:

Type of message	Type of service								
	Code	0	RES 1	AT 2	AP 3	ECH 4	MR 5	AD 6	APR 7
DEM	1	-	X	X	X	X	X	-	-
REP	2	X	X	X	X	X	X	-	-
MNS	3	-	-	-	-	-	-	X	X

### 7 - Number of the requesting terminal

Length = 7, coding = alphanumerical

The terminal number is made up as follows:

5 digits: main code location part as specified in *ERA TAP TSI Technical Document B.9* (see Bibliography). If this is not possible, another code is permissible.

2 digits: serial number of the terminal in the office.

For protocol messages, this element contains the value = 0000000.

### 8 - Type of requesting office or type of protocol message

Length = 1, coding = numerical

#### Reservation:

See Code List B.5.8

### 9 - Number of the application version

Length = 1, coding = numerical

In the operation, the same version number applies for all connected reservation systems. If it is changed, a standard first validity day must be specified for all reservation systems.

0 = Standard version

1 = Non-standard version

### 10 - Field at disposal

Length = 2, coding = alphanumerical

#### Reservation:

The field contains information from the requesting system which must be quoted back unchanged by the replying system (not with protocol messages).

With protocol messages, the following values are possible:

### Reply to a synchronisation request

#### Code = 00

- correction of the reservation file was needed (reservation or partial cancellation request), the reservation was corrected,
- the cancellation was processed (the reservation file was already corrected),
- the complete cancellation was effected (the reservation file remains unchanged).

#### Code = 20

- The receiving application cannot recover (lost dialogue). Inclusion in the litigation files by the sending reservation system.

#### Code = 30

- The original request was not processed or negatively replied:
  - for cancellations, the sending reservation system includes it in the litigation file
  - for a reservation, partial or complete cancellation request, no special processing takes place.

### Synchronisation requests

#### Code = 00

- the session was interrupted.

#### Code = 10

- a time-out occurred.

–

### Throughput messages

Not being used for the seat reservation application for the time being.

#### Code 01-99

- specified throughput quota.

## 11 - Test

Length = 1, coding = numerical

See Code List B.5.11

**In case of a reservation request** with this value 9 the reply messages should at least contain the correct price, at the time when the reply was sent, for the requested tariff, class, etc. If the tariff is not allowed, or not available for the requested train the reply should be a negative reply. The reference number element should in the first 2 positions hold the reservation system number, while the following digits should hold 10 zeroes.

The desired (but not obligatory) action is that the request is evaluated identical to a real booking, but the booking is not made persistent. In that case if no place (or no place with requested attributes including tariff) is available the result should be a negative reply. It is desired, that in a positive reply the element 50 contains relevant place numbers and correct place codes, element 27 the relevant coach number and element 51 the type of compartment that could have been allocated.

No accounting record will be made for these transactions. There must not be correction or synchronisation requests made related to these transactions.

**In case of a cancellation info request (includes partial cancellation info)** with this value 9, the reply message should at least contain the correct refund amount for the number of cancelled places at the time when the reply was sent. The reference number element in the partial cancellation reply should in the first 2 positions hold the reservation system number, while the following digits should hold 10 zeroes.

The desired (but not obligatory) action is that the request is evaluated identical to a real cancellation, but the cancellation is not made persistent. If for the requested tariff no refund is defined, than it will be given a positive reply with the refund amount is zero.

In case of a given incorrect reference number, wrong tariff, wrong number of places etc. a negative reply will be sent.

No accounting record will be made for these transactions. There must not be correction or synchronisation requests made related to these transactions.

## 12 to 14 - Not used

### 3.2. Prefix "Application Text"

#### 15 - Service

Length = 2, coding = numerical

See Code List B.5.15

#### 16 - Type of the request or reply

Length = 1, coding = numerical

0 = Listing

1 = Request for normal seat

2 = Request for a particular seat

3 = Request for adjacent seat

4 = Confirmation

5 = Replacement proposal for other service

6 = Replacement proposal for other train

7 = Replacement proposal for other reservation system

8 = Negative reply

9 = Free

The tables below give the possible combinations of the service elements and type of the request or reply.

The following combinations are possible for requests:

Service	Type of request			
	Code	N 1	D 2	V 3
ASS	01	X	X	X
CC	02	X	X	X
VL	03	X	X	X
RP	04	X	X	X
VR	05	X	-	-
AUT	06	X	-	-
AUB	30	X	-	-
PB	31	X	-	-
VSC	40	X	-	-
HO	50	X	-	-

In the event of cancellation and exchange requests, the element type of request is not significant (Coding = 0).

The following combinations are possible for replies:

Service	Type of reply					
	Code	ACC 4	PRP 5	PRT 6	PRR 7	RN 8
ASS	01	X	X	X	X	X
CC	02	X	X	X	X	X
VL	03	X	X	X	X	X
RP	04	X	X	X	X	X

<b>VR</b>	05	X	-	-	X	X
<b>AUT</b>	06	X	-	X	X	X
<b>AUB</b>	30	X	-	X	X	X
<b>PB</b>	31	X	-	X	X	X
<b>VSC</b>	40	X	-	-	-	X
<b>HO</b>	50	X	-	-	-	X

For replies to cancellation or exchange requests, only the codings 4 (confirmation) and 8 (negative reply) are possible for the element type of reply.

For replies to a rectification, only the codings 4 (confirmation) and 8 (negative reply) are possible.

### 17 - Serial number

Length = 2, coding = numerical

Application texts are transmitted together in a message, that is to say with a particular dialogue number and connected by the serial number. The numbering is done in decreasing order.

The lowest value is "01".

### 18 - Type of text

Length = 2, coding = numerical

See Code List B.5.18

### 19 – Not used

#### 3.3. Application text

### 20 - Train

Length = 5, coding = alphanumerical

#### 20A Train number

In the requests, this is generally the number which the train has at the boarding station of the passenger or at the departure station of the car-carrying train.

In the confirmations, it is always the number which the train has at the boarding station of the passenger or the loading station of the car.

In the replacement proposals, it is the number of the proposed train.

#### 20B Original train number

This is the train number in which the ticket to be exchanged was issued.

#### 20C Train number for return journey



## 21 - Date

Length = 4, coding = numerical

2 digits for the day

2 digits for the month

### *21A Departure date*

In the requests and in the confirmations, this is the date of departure of the train from the passenger's boarding station or the departure date of the car-carrying train. In the replacement proposals, it is the departure date of the proposed train if this differs from that of the requested train.

### *21B Original departure date*

This is the date of departure on the ticket to be exchanged.

### *21C Loading date*

This is the car loading date at the departure station of the car-carrying train.

### *21D Unloading date*

This is the date on which the car is unloaded at the arrival station of the car-carrying train.

### *21E Date of breakfast*

This is given when the date of the meal is different from the departure date at boarding station.

### *21F Date of lunch (see element 21 E)*

### *21 G Date of dinner (see element 21 E)*

### *21H Arrival date*

This is the arrival date of the train at the destination station of the passenger.

## 22 - Station codes

Length = 7, coding = numerical

2 digits for country code + 5 digits for station codes (as specified in *ERA TAP TSI Technical Document B.9*)

### *22A Boarding station*

### *22B Destination station*

### *22C Starting station*

This is the first station of the journey to which the message refers.

### *22D Final station*

This is the last station of the journey to which the message refers.

#### *22E Return station*

This is the code for the return station of a forward and return journey, if the final station is different from the starting station.

#### *22F First intermediate station*

This is the first (or only) intermediate station on the journey. It defines a stopping station or a station passed through on the train journey.

#### *22G Second intermediate station*

This is the second intermediate station in the journey. It defines a stopping station or a station passed through on the train journey.

### **23 - Seats (number)**

Length = 2, coding = numerical

01 to 40 for VL

01 to 16 for CC1

01 to 36 for ASS and CC2

#### *23A Number of seats*

For partial cancellation, this is the number of remaining seats with following restrictions:

01 to 39 for VL

01 to 15 for CC1

01 to 35 for ASS and CC2

#### *23B Number of cancelled seats*

#### *23C Number of overbooked seats*

#### *23D Number of smoking seats*

#### *23E Number of non-smoking seats*

### **24 - Class**

Length = 1, coding = alphanumerical

See Code List B.5.24

### **25 - Berths (type and number)**

Length = 12, coding = numerical

1st	+	2 <sup>nd</sup> digits	=	Single (max. 18)
3rd	+	4 <sup>th</sup> digits	=	Special (max. 18)
5th	+	6 <sup>th</sup> digits	=	Double (max. 36)
7th	+	8 <sup>th</sup> digits	=	T2 (max. 36)
9th	+	10th digits	=	T3 (max. 39)
11 <sup>th</sup>	+	12th digits	=	T4 (max.40)

Only the following combinations are possible:

1st	+	2nd digits (value = 01) and	5th	+	6th	digit (value = 02)
1st	+	2 <sup>nd</sup> digits (value = 01) and	9th	+	10th	digit (value = 03)
5th	+	6 <sup>th</sup> digits (value = 02) and	9th	+	10th	digit (value = 03)
3rd	+	4 <sup>th</sup> digits (value=01) and	7th	+	8th	digit (value=02)

### *25A Type and number of berths*

For partial cancellations, this is the number of remaining berths with following restrictions:

01 to 39 for VL

01 to 15 for CC1

01 to 35 for ASS and CC2

### *25B Type and number of cancelled berths*

## **26 - Meals**

Length = 6, coding = numerical

2 digits = Number of breakfasts

2 digits = Number of lunches

2 digits = Number of dinners

### *26A Type and number of meals*

Refers, for partial cancellation, to the type and number of remaining meals.

### *26B Type and number of cancelled meals*

## 27 - Coach number

Length = 3, coding = alphanumerical

Number of coach in which the seats are requested.

The element can be empty in some special cases:

- i.e.:
- cycle places without coach number
  - ferry places without coach number
  - bus places without coach number
  - overbooked seats

According to the general rules of the Technical Document, “empty” means filled with blanks.

## 28 - Seat number

Length = 3, coding = alphanumerical

### *28A Number of a particular seat*

Number of the seat requested by the passenger.

Can also be “blank” (only in the case of berths) and then means any berth or berths in the coach in question.

### *28B Number of a reference seat*

Number of the seat on which the allocation of the desired seats should be based; it must be the closest seat to the reference seat within the compartment concerned.

## 29 - Category of vehicle/boat

Length = 1, coding = numerical

See Code List B.5.29

### *29A Vehicle category*

### *29B Boat category*

### *29C Category of the cancelled vehicle*

### *29D Category of the cancelled boat*

## 30 - Vehicle registration

Length = 10, coding = printable characters

### 31 - Number and ages of the passengers

Length = 8, coding = numerical

- 1st digit = number of adults in 1st Class
- 2nd digit = number of children from 4 to 5 years old in 1st Class
- 3rd digit = number of children from 5 to 12 years old in 1st Class
- 4th digit = number of children from 12 to 15 years old in 1st Class
- 5th digit = number of adults in 2nd Class
- 6th digit = number of children from 4 to 5 years old in 2nd Class
- 7th digit = number of children from 5 to 12 years old in 2nd Class
- 8th digit = number of children from 12 to 15 years old in 2nd Class

In case of requests for a car carriage place only the element has to be filled with zeroes completely.

### 32 - Journey number

Length = 1, coding = numerical

Serial number, indicating the order in which successive journeys are made. In the case of single journey, the journey number will be zero.

### 33 - Journey code

Length = 1, coding = numerical

Shows whether the request refers to a single journey or to one of a number of sections of a journey.

See Code List B.5.33

### 34 - Reference number

Length = 12, coding = numerical

The seats or meals originally booked which are to be cancelled or exchanged can be identified from the reference number:

The reference number formed according to the rules of each RS must be sufficiently reliable to ensure that places cannot be erroneously released by mistyped reference numbers.

The elements from the request:

- Train number
- Travel date
- Type of service

must be checked to comply with the booking referenced by the reference number given in the cancellation and partial cancellation request.

The reference number must be unique combined with the train number and the travel date. However it is recommended to use intrinsically unique reference numbers unique for one year.

2 digits for the reservation system, having allocated the seats or responsible for the ticket, and 10 digits for the actual reference number

#### *34A Reference number of reservation ticket to be cancelled*

#### *34B Reference number of accommodations*

Concerns the reservation of seats, couchettes, berths or car places.

#### *34C Reference number for breakfast*

Concerns the allocation of breakfast in the coach with meals at seat or in the restaurant car.

#### *34D Reference number for lunch*

Concerns the allocation of lunch in the coach with meals at seat or in the restaurant car.

#### *34E Reference number for dinner*

Concerns the allocation of dinner in the coach with meals at seat or in the restaurant car.

#### *34F Reference number of cancelled reservation ticket*

#### *34G Reference number of ticket issued*

This element describes the identification number of a pre-printed ticket or a printed ticket at the time of issue.

#### *34H Reference number of travel ticket to be cancelled*

#### *34I Reference number of cancelled ticket*

### **35 - Smoking/non-smoking**

Length = 1, coding = numerical

See Code List B.5.35

### **36 - Position of seat**

Length = 4, coding = numerical

This field, which consists of 4 individual digits, gives the number of seats desired in the respective position (maximum 2).

Should the request for a certain seat be considered as mandatory, the digit concerned must be increased by 5. This is only used at present for "lower couchette places mandatory". 1 and 2 become 6 and 7.

The digits mean:

	Number		
	Seats	Couchettes	Sleeper berths
1st digit	window	upper	upper
2nd digit	middle	middle	middle
3rd digit	gangway	lower	lower
4th digit	window isolated	-	-

In the event of partial cancellation, this gives the number of the remaining seats for each place position.

### 37 - Compartment request

Length = 6, coding = numerical

The element consists of 3 sub-elements.

1st and 2nd positions: type of coach

See Code List B.5.37.1

3rd and 4th position: compartment with special features

See Code List B.5.37.2

5th and 6th position: special offer/allocations

See Code List B.5.37.3

The offer of the various Tour-Operators is released by agreement at various times before the date of travel depending on the particular train (e.g. 21 days or 3 days) for the general reservation service.

### 38 - Position of compartment

Length = 1, coding = numerical

This element indicates the desired level of the seats or the sleeping-car compartment

#### 38A Position of compartment/request

See Code List B.5.38.1

*38B Position of compartment/allocation*

See Code List B.5.38.2

Concerns the level of the remaining seats or compartments in the case of partial cancellation.

### **39 - Compartment with connecting door**

Length = 1, coding = numerical

1 = compartment with connecting door desired or allocated in the response

### **40 - Compartment characteristics**

Length = 1, coding = numerical

See Code List B.5.40

### **41 - Time**

Length = 4, coding = numerical

2 digits for the hour                      Local time in 24 hour system  
2 digits for the minute

*4 1A Departure time*

This is the departure time from the station where the passenger boards.

*41B Time of lunch*

*41C Time of dinner*

*41D Start of loading period*

*41E End of loading period*

*41F Start of unloading period*

*41G End of unloading period*

*41H Arrival time*

This is the arrival time at the station where the passenger alights. The element 41H has to be delivered even if it is marked as optional element in the message.

*41I Start of additional loading period*



*41J End of additional loading period*

*41K Start of additional unloading period*

*41L End of additional unloading period*

*41M Waiting time at first intermediate station*

Length of waiting time at the first intermediate station.

*41N Waiting time at second intermediate station*

Length of waiting time at the second intermediate station

*41O Departure time of the return journey*

Departure time of the return journey

## **42 - Tariff**

Length = 9, coding = numerical

1st and 2nd digits = 2-position reason for reduction (00 - 99)

Code as specified in Code List B.5.42

3rd, 4th, 5th and 6th digits = 4-position reason for reduction (0100 - 9999)

7th digit = Free

8th and 9th digits = Number of passengers with price reduction

Where the value "04" is shown in the 1st and 2nd digits, only the 4-position reason for reduction in digits 3 to 6 applies. If the 4-position reason for reduction is not used, digits 3 to 6 = zero.

*42A Tariff 1*

Marks a deviation from the normal fare. Concerns the remaining seats for partial cancellations.

*42B Tariff 2*

Marks a second deviation from the normal fare. Concerns the remaining seats for partial cancellations.

## **43 - Individual reservation tickets requested**

Length = 1, coding = numerical

The allocating system should give a reservation confirmation (that is to say a reservation ticket) for each reserved seat requested.

See code list B.5.43

**44 - Another train acceptable**

Length = 1, coding = numerical

1 = Desired train

See code list B.5.44

The passenger accepts another train to the one requested.

**45 - Trailers**

Length = 1, coding = numerical

See Code List B.5.45

*45A Trailer category*

*45B Category of the cancelled trailer*

**46 - Number of dogs**

Length = 1, coding = numerical

**47 - Reservation system**

Length = 2, coding = numerical

Codes see element 1.

*47A Requesting reservation system*

This element describes the issuing railway coded with the reservation system code in case this railway is different from the requesting reservation system.

In case the message element is mandatory (correction message) the element should contain the issuing railway, even if it is the same as the code of the requesting reservation system.

*47B Reservation system with further seat offer*

This is the reservation system with a further seat offer to which the requesting reservation system can turn.

**48 - Train category**

Length = 2, coding = numerical

The element 48 (train category) shall not be processed in the messages.

**49 - Station names**

Length = 30, coding = printable characters

The method of writing given in *ERA TAP TSI Technical Document B.9* is used.

*49A Name of boarding station*

*49B Name of destination station*

*49C Name of loading station*

*49D Name of unloading station*

*49E Name of boarding station (start of journey)*

*49F Name of destination station (end of journey)*

Together with element 49E, this is the route of the passenger in connection with a car reservation with inclusive price calculation.

*49G Name of first intermediate station*

*49H Name of second intermediate station*

## **50 - Place allocation**

Length = 32, coding = by characters

The field consists of a maximum of 8 sub-elements, which are sub-divided as follows:

3 digits place number (alphanumeric)

1 digit place code (by characters)

The element can be empty in some special cases:

- i.e.:
- bicycle places without place number
  - ferry places without place number
  - bus places without place number
  - overbooked seats

According to the general rules of the Technical Document “empty” means filled with blanks.

The codes are described below:

### **1. Seats and seats with meals at seat**

See Code List B.5.50.1

### **2. Couchette berths**

See Code List B.5.50.2

### 3. Berths

See Code List B.5.50.3

Codes to be used for places in compartments without separated gender. These codes are to be used only if the places have been requested by code “mixed” in element 40.

See Code List B.5.50.4

*50A Accommodation allocated*

*50B Additional accommodation allocated*

Enables the issue of further allocated seats, if all 8 sub-elements of element 50A are already filled.

However no from-to number sequences may be split from element 50A into the element 50B.

### 51 - Type of compartment allocated

Length = 6, coding = numerical

The element consists of three sub-elements. 1st and 2nd positions: type of coach

See Code List B.5.51.1

3rd and 4th positions: compartment special features

See Code List B.5.51.2

5th and 6th positions: special offers/contingent

See Code List B.5.51.3

The offer of the various Tour-Operators is withdrawn by agreement at various times before the date of travel depending on the train (e.g. 21 days or 3 days) and then made available for the general reservations.

## **52 - Amount**

Length = 7, coding = numerical

5 digits for the euro

2 digits for the cent

The amount is given in euro, provided no other currency is defined in the element currency code in the same application text.

### *52A Amount (supplement, global price IRT)*

This element normally contains the total amount (supplement, global price IRT).

For inclusive amount calculation in car-carrying trains, the amount may also include the cost of travel tickets for the passengers.

For partial cancellations, the amount relates to the remaining seats.

Reservation fees are calculated by the issuing railway and are not included in the message exchange.

### *52B Amount of breakfast*

For partial cancellations, the amount relates to the remaining seats.

### *52C Amount of lunch*

For partial cancellations, the amount relates to the remaining seats.

### *52D Amount of dinner*

For partial cancellation, the amount relates to the remaining seats.

### *52E Amount of refund*

If the amount differs from the amount of the original reservation, element 75 is delivered. For partial cancellation, the amount is the refund of the cancelled places + the amount of remaining places.

### *52F Amount*

This element contains the product amount in 918E replies.

### *52G VAT-amount*

The amount of VAT.

### **53 - Number of the entry in loading list**

Length = 3, coding = numerical

### **54 - Price calculation code**

Length = 1, coding = numerical

This gives the rules used by the allocating reservation system for the price calculation for car-carrying traffic.

See Code List B.5.54

### **55 - Number of passengers**

Length = 4, coding = numerical

1st digit	= Number of adults in 1st Class
2nd digit	= Number of children in 1st Class
3rd digit	= Number of adults in 2nd Class
4th digit	= Number of children in 2nd Class

### **56 - Change of train/date**

Length = 1, coding = numerical

Note about change in the customer's wishes regarding train number and/or date of travel.

See Code List B.5.56

Only the value = 1 is possible for an exchange

### **57 - Change of station**

Length = 1, coding = numerical

Note about change in the customer's wishes regarding stations.

See Code List B.5.57

### **58 - Number of supplements**

Length = 2, coding = numerical

Details of the number of supplements to be paid for.

### **59 - Type of supplements**

Length = 1, coding = numerical

See Code List B.5.59

### **60 - Number of night sectors**

Length = 1, coding = numerical

The number of night sectors is required for the exact calculation of the price in the national currency of the issuing reservation system.

The information only appears if the number of night sectors is greater than 1.

### **61 - Request number**

Length = 2, coding = numerical

For combined requests, the request number enables a replacement proposal or a negative reply to be given to the appropriate request.

This element contains the serial number of the request.

### **62 - Available services**

Length = 9, coding = alphanumerical

When the required service is sold out, this gives the services still available in the requested train or available services in an alternative train.

See Code List B.5.62

Each of the 9 positions may contain one of the above-mentioned codes. A maximum of 9 replacement proposals are possible.

### **63 - Reply code**

Length = 3, coding = numerical

The code gives the reason for the negative reply.

See Code List B.5.63

**64 - Date of the original reservation**

Length = 5, coding = numerical

Display: YYDDD

Consists of the sub elements:

- Year: YY
- Day number: DDD

**65 - Undertaking providing the service**

Length = 1, coding = numerical

See Code List B.5.65

**66 - Text for special offer**

Length = 30, coding = printable characters

*66A Notices*

**67 - Type of price**

Length = 1, coding = numerical

See Code list B.5.67

**68 - Number of the original dialogue**

Length = 5, coding = numerical

**69 - Vehicle transport price only**

Length = 1, coding = numerical

1 = Vehicle transport price only

Indicates to the allocating system when making an inclusive price calculation that it must only calculate the cost for transporting the car.

**70 - Loading lower deck**

Length = 1, coding = numerical

See Code List B.5.70

**71 - Height**

Length = 3, coding = numerical

Details of vehicle height in centimetres



**72 - Free****73 - Partial price**

Length = 14, coding = numerical

The element consists of 3 sub-elements and details the composition of element 52

1st-5th digit = Tariff code

6th-7th digit = Number of individual prices  
(e.g. passengers, compartments, etc.)

8th-14th digit = Individual price in euro

*73A Partial price 1**73B Partial price 2**73C Partial price 3*

The elements 73A, 73B and 73C are used for reservation, partial cancellation and exchange confirmations.

*73D Partial price 4**73E Partial price 5**73F Partial price 6*

The elements 73D, 73E and 73F are used for partial cancellation and complete cancellation confirmation for the price of the original reservation.

The element 73 provides a split of the prices in element 52A and 52E per tariff and person. It can be used in currency conversion to avoid rounding errors.

$$\text{local price} = \text{persons-tariff-0} * (\text{rounded / converted price element 72 (tariff 0)}) + \text{persons-tariff-1} * (\text{rounded / converted price element 72 (tariff 1)}) + \text{persons-tariff-2} * (\text{rounded / converted price element 72 (tariff 2)})$$

which is different from:

$$\text{local price} = \text{total number of persons} * \text{rounded / converted total price (Element 52A)}$$

By using the partial price the prices remain additive (e.g. two persons pay the double price also in local currency).

Elements 73A/B/C correspond to the price in 52A, Elements 73D/E/F split the price of element 52E.

Example on partial price element:

One reservation with 2 adults (Tariff 72 and 1 child (tariff 73):

- 2 x Tariff 72 (Adult) partial price 22,60 €
  - 1 x Tariff 73 (Child) partial price 15,40 €
- total price: 60,60 €

- message element: "000720200022600073010001540000000000000000"

local currency SFR: 1 : 1,20 rounding up to 0.10 SFR

- simple conversion:  $60,60 * 1,20 = 72,72$ 
  - → 72,80 SFR
- using partial price element:
  - $22,60 * 1,20 = 27,12 \rightarrow 27,20$  SFR
  - $15,40 * 1,20 = 18,48 \rightarrow 18,50$  SFR

→ 72,90 SFR

#### **74 - Reason for cancellation**

Length = 2, coding = numerical

See Code List B.5.74

#### **75 - Mark of changed price**

Length = 1, coding = numerical

See Code list B.5.75

#### **76 - Code of the travel agent's organisation**

Length = 5, coding = numerical

#### **77 - Passenger with vehicle**

Length = 1, coding = numerical

See Code List B.5.77

#### **78 - Carrier**

Length = 4, coding = alphanumerical

See codes specified in *ERA TAP TSI Technical Document B.8.*

**79 - List of carriers**

Length = 36, coding = alphanumerical

The list of carriers comprises the following 9 sub-elements:

No.	Element	L + C
78	Carrier	4 A
78	Carrier	4 A
78	Carrier	4 A
78	Carrier	4 A
78	Carrier	4 A
78	Carrier	4 A
78	Carrier	4 A
78	Carrier	4 A
78	Carrier	4 A

**80 - Country code of the requesting terminal**

Length = 2, coding = alphanumerical

Coding in accordance with *ISO standard 3166* 2-position alphabetical code

**81 – Service brand information**

Length = 40, coding = printable characters

The element is composed of three sub elements:

NUM	Element	L+C
82	Service brand code	4 N
83	Abbreviation of service brand	3 C
84	Service brand name	33 C

The element 81 has to be delivered even if it is marked as optional element in the message.

81 A – Service brand information for a return train

## 82 – Service brand code

Length = 4, coding = numerical

See Code List B.5.82

82 A – Service brand code for a return train

## 83 – Service brand abbreviation

Length = 3, coding = printable characters

See Code List B.5.83

Abbreviation used for printing on RCT2 tickets.

## 84 – Service brand name

Length = 33, coding = printable characters

See Code List B.5.84

Full text used for printing on RCT2 tickets.

## 85 - Places (number)

Length = 4, coding = numerical

Number of places

## 86 – Cancellation time limits

Length = 96, Format = alphanumeric

Length 8 x 12 (up to 8 reasons incl. „no reason“), Format = alphanumeric

Date and Time up to then the cancellation can be made with the specified reasons of cancellation or no reason at all. If the reason is not listed the free cancellation time limit is unspecified.

An entry might be left blank if the information is not given for all reasons. In this case the complete element should be left blank.

Date and Time are given in [Coordinated Universal Time \(UTC\)](#)!

<u>Num</u>	<u>Element</u>	<u>L + C</u>												
86	Cancellation Time Limits 8 x : time limit per reason code	96 C												
	<table border="1"> <thead> <tr> <th>Num</th> <th>Element</th> <th>L + C</th> </tr> </thead> <tbody> <tr> <td>74</td> <td>Reason for cancellation 00 == cancellation without reason</td> <td>2 N</td> </tr> <tr> <td>326</td> <td>Date DDMMYY</td> <td>6 N</td> </tr> <tr> <td>41</td> <td>Time HHmm</td> <td>4 N</td> </tr> </tbody> </table>		Num	Element	L + C	74	Reason for cancellation 00 == cancellation without reason	2 N	326	Date DDMMYY	6 N	41	Time HHmm	4 N
Num	Element		L + C											
74	Reason for cancellation 00 == cancellation without reason		2 N											
326	Date DDMMYY		6 N											
41	Time HHmm	4 N												

If a reason for cancellation is missing the free cancellation time limit is unspecified for that reason and might have any date and time.

## 88 – Original Cancellation Date

Length = 6, coding = numerical YYMMDD

In case of a cancellation request on a reservation that was already cancelled before the allocating system has two options to react. It can return a negative reply with the appropriate error code indicating that the reservation was already cancelled.

As a second option the allocating system can return the cancellation confirmation again and must then indicate the date of the original cancellation in the reply message with using this element. This option can be used to limit the impact of errors in case of time out in a cancellation message exchange.

The date is given in the time zone of the allocating system.

## 89 – Original Cancelling reservation system

Length = 2, coding = numerical

Codes from the reservation systems code list element 01.

In case of a cancellation request on a reservation that was already cancelled before the allocating system has two options to react. It can return a negative reply with the appropriate error code indicating that the reservation was already cancelled.

As a second option the allocating system can return the cancellation confirmation again and must then indicate the reservation system that made the original cancellation in the reply message with using this element. This option can be used to limit the impact of errors in case of time out in a cancellation message exchange.

## 90 - FulfillmentMedium

Length = 3, coding = alphanumerical

Up to 3 ordered entries of fulfillment Medium possible ordered by preference.

Corresponds to FulfillmentMedium Tag in XML.

Codes:

- " " – blank in case less than 3 Medium are provided
  - A - "RCT2" security feature for secure paper RCT2
  - B - "RCCST" security feature for secure paper RCCST
  - C - "paper" security feature for blank paper
  - D - "phone" security feature for smart phone
  - E - "noMedium" travelling with a name an Id or Card (SIS Security in System)
- F = A or B  
H = C or D

In the request message the fulfilment Medium supported by the issuer are indicated ordered by the preference of the passenger. In the reply message the fulfilment Medium allowed are indicated ordered by preference of the allocator.

## 91 PassengerData

Length = 400, coding = alphanumerical with special characters (C)

A comma separated list of passenger data containing a list of the following elements. Multiple passengers are separated by a semicolon.

- PassengerLink and birth date:
  - PassengerLink: 1 character – linking the passenger in the request with the passenger in the reply in case of ticket URLs or ids per passenger (Elements 94/95). The Linking should start with 1 and continue with letters in case more than 9 passengers are used.
  - Date of Birth: DDDYYYY to be filled with blanks if not provided
- “,” separator
- First Name: alphanumeric
  - In info requests “Xx” is used
- “,” separator
- Last Name: alphanumeric
  - In info requests “Yy” is used
- “,” separator
- E-mail
- “,” separator
- Country of birth (ISO-Code 2A)
- “,” separator

Data of the passengers are separated by a semicolon “;”, data of one passenger are separated with a “,”.

e.g.:

Passengers:

John Doe born 1.1.1954

Jane Doe born 20.11.1985

10011954,John,Doe,john.doe@yahoo.com;23241985,Jane,Doe,jane.doe@yahoo.com

The remaining space of the element has to be filled with blanks.

In case the space is not sufficient the element 92 can be used to continue the data.

Note: SNCF will not be able to process the large element.

In case of a partial cancellation request the passenger data of the passengers kept are provided.

In case the space is not sufficient the content needs to be shortened. Optional elements (e-mails) can be removed. The first name can be shortened.

## 92 - PassengerDataExtension

Length = 1000, coding = alphanumerical with special characters (C)

For content specification see Element 91.

## 93 - CancelledPassengerIds

Length = 70, coding = alphanumerical

Comma separated list of passengerIds for the passengers to be cancelled from the original booking. The passengerIds must have been provided in the reservation reply.

## 94 - eTicketData

Length = 500, coding = alphanumerical with special characters (C)

A comma and semicolon separated list of the following elements:

- ControllId
- “ ”
- URL document type – default is pdf download for eticket
- “ ”
- URL
- Per Passenger:
  - “;” semicolon to indicate the start of the data for one passenger.
  - PassengerLink: 1 character to link the passenger in the request to the passenger data in the reply. This is the passengerLink received in the elements 91/92 identifying the passenger.
  - “ ”
  - passengerId: allocators id of the passenger in this ticket
  - “ ”
  - URL document type
  - “ ”
  - URL

e.g.:

ABCZYX,,;http://example.com/myticket.pdf

or

ABCZYX,,;1,3425653276,,http://example.com/JohnDoesTicket.pdf;2,5268767,,http://example.com/JohnDoesTicket.pdf

URL document type:

Default: download link for a pdf ticket

The URL type provides information on the format of the ticket to be downloaded. The issuer can decide whether the format is supported for his clients before downloading the file.

A: pdf

B: any



## 95 - eTicketDataExtension

Length = 2000, coding = alphanumerical with special characters (C)

Element to be used in case the space in element 94 is not sufficient.

SNCF will not be able to process this large element.

## 96 - Exchange Reference

Length = 12 + 5 + 7

N12: Reference number of reservation to be exchanged

A5: Train number of reservation to be exchanged

N7: Travel date of reservation to be exchanged (DDDDYYYY)

## 97 to 299 - Not used

**300 - Availability information**

Length = 8, coding = alphanumerical

Each element of availability information consists of the following sub-elements:

No.	Element	L + C
308A	Fare code 1	4A
23D	Number of smoking seats	2 N
23E	Number of non-smoking seats	2 N

**In Application Version 2:**

NUM	Element	L + C
308A	Service Level - Tariff Link	4 A
85	Number of Places	4 N

*300A Availability information 1*

*300B Availability information 2*

*300C Availability information 3*

*300D Availability information 4*

*300E Availability information 5*

*300F Availability information 6*

*300G Availability information 7*

**301 - 302 - Not used****304 – Not Used**

Length = 1, coding = numerical.

**305 - Currency code**

Length = 3, coding = alphanumerical

This element describes the currency of a price or a price group. If this element is not given, the price is given in euro. The currency is defined using the ISO 4217 codes "*Codes for the representation of currencies and funds*".

**306 – Not Used**

Length = 30, coding = printable characters

**307 – Not Used**

Length = 12, coding = alphanumerical

**308 - Service Level - Tariff Link**

Length = 4, coding = alphanumerical

This element can be used to give special types of price, price ranges or price stages.

The 1st + 2nd positions of this element contain a code which designates the accommodation category.

See Code List B.5.308

The 3<sup>rd</sup> and 4<sup>th</sup> position contain an arbitrary code used to provide a unique link between the availability information elements (element 300) and the tariff information element (element 328) in one application text. The code is unique within one application text only. The code has no meaning as a standalone code.

*308A Fare code 1*

*308B Fare code 2*

*308C Fare code 3*

**309 – Not used****310 – Not Used**

Length = 4, coding = numerical

**311 - Number of combined messages**

Length = 2, coding = numerical

This element gives the number of combined requests which belong to a special message.

**312 – 313 Not Used****314 - Product code**

Length = 10, coding = alphanumerical

This element can be used to identify a certain product in a product catalogue.

**315 - Product identifier**

Length = 3, coding = numerical

This element can be used to identify a certain part of a product.

1st and 2nd position = service (element 15), and

3rd position = partial identifier of product from the product catalogue .

### **316 - Purchase conditions**

Length = 3, coding = numerical .

1st digit: Booking restrictions

See code list B.5.316.1

2nd digit: Conditions for use

See code list B.5.316.2

3rd digit: Refund conditions

See code list B.5.316.3

### **318 - Service code**

Length = 2, coding = alphanumerical

The first position contains the physical class and the second contains the service level. 1st position:

See code list B.5.318 2<sup>nd</sup> position " " or "0" = Not significant *318A Service code 1*

*318B Service code 2 (not used at present)*

*318C Service code 3 (not used at present)*

### **319 - Service identifier**

Length = 1, coding = numerical

See Code List B.5.319

*319A Catering identifier*

*319B Luggage identifier*

*319C Bicycle identifier*

*319D Disabled equipment identifier*

*319E Hotel identifier*

*3 19F Hire car identifier*

*319G Connection identifier*

*319H Public transport identifier*

### **320 - Service information type**

Length = 1, coding = numerical

See Code List B.5.320

### **321 - Text groups - identifier**

Length = 2, coding = numerical

The first position contains the group number and the second position the group element.

If application texts are combined in a request or reply, this element allows the identification of a group and its elements. Each position is an independent serial number: for groups the first position, and for the application texts within the group the second position. The numbering is in descending order for both positions, and the lowest value is 1.

### **322 - Text - identifier**

Length = 3, coding = numerical

3-position identifier for a free text format in the language of the receiver of the message.

*322A Conditions of use*

*322B Product information*

### **323 - Ticket issue identifier**

Length = 1, coding = numerical

0 = Ticket-issue confirmation not necessary

1 = Ticket-issue confirmation necessary

### **324 - Type of ticket**

Length = 1, coding = alphanumerical

0 = Not significant

1 = Not specified

2 = ATB

3 = Credit Card format

**325 - Rate of VAT**

Length = 3, coding = numerical

**326 - Date**

Length = 6, coding = numerical

2 digits for the day

2 digits for the month

2 digits for the year

*326A Departure date*

*326B Arrival date*

*326C Departure date of the return journey*

**327 - Tariff code**

Length = 2, coding = alphanumerical

Possible values: See Code List B.5.327

**Different definition when Application Version = 1 in Element 9**

Length = 4, coding = alphanumerical

Possible values: reserved

*327A Tariff code 1*

*327B Tariff code 2*

*327C Tariff code 3*

*327D Tariff code 4*

**328 - Tariff Table**

Length = 13, coding = alphanumerical

Each element in the Tariff Table consists of the following sub-elements:

No.	Element	L + C
308A	Fare code 1	4A
67	Type of price	1 N
327A	Tariff code 1	2A
327B	Tariff code 2	2 A
327C	Tariff code 3	2 A
327D	Tariff code 4	2 A

**Different definition when Application Version = 1 in Element 9**

Length = 21, coding = alphanumerical

Each element in the Tariff Table consists of the following sub-elements:

No.	Element	L + C
308A	Fare code 1	4A
67	Type of price	1 N
327A	Tariff code 1	4A
327B	Tariff code 2	4 A
327C	Tariff code 3	4 A
327D	Tariff code 4	4 A

**329 - Tariff Table2**

Length = 26, coding = alphanumerical

The element Tariff Table 2 consists of the following sub-elements:

No.	Element	L + C
328	Tariff Table	13 A
328	Tariff Table	13 A

**Different definition when Application Version = 1 in Element 9**

Length = 42, coding = alphanumerical

The element Tariff Table 2 consists of the following sub-elements:

No.	Element	L + C
328	Tariff Table	21 A
328	Tariff Table	21 A

**330 - Tariff Table 4**

Length = 52, coding = alphanumerical

The element Tariff Table 4 consists of the following sub-elements:

No.	Element	L + C
328	Tariff Table	13 A
328	Tariff Table	13 A
328	Tariff Table	13 A
328	Tariff Table	13 A

**Different definition when Application Version = 1 in Element 9**

Length = 84, coding = alphanumerical

The element Tariff Table 4 consists of the following sub-elements:

No.	Element	L + C
328	Tariff Table	21 A
328	Tariff Table	21 A
328	Tariff Table	21 A
328	Tariff Table	21 A

**331 - Tariff Table 8**

Length = 104, coding = alphanumerical

The element Tariff Table 8 consists of the following sub-elements:

No.	Element	L + C
328	Tariff Table	13 A
328	Tariff Table	13 A
328	Tariff Table	13 A
328	Tariff Table	13 A
328	Tariff Table	13 A
328	Tariff Table	13 A
328	Tariff Table	13 A
328	Tariff Table	13 A
328	Tariff Table	13 A

**Different definition when Application Version = 1 in Element 9**

Length = 168, coding = alphanumerical

The element Tariff Table 8 consists of the following sub-elements:

No.	Element	L + C
328	Tariff Table	21 A



328	Tariff Table	21 A
328	Tariff Table	21 A
328	Tariff Table	21 A
328	Tariff Table	21 A
328	Tariff Table	21 A
328	Tariff Table	21 A
328	Tariff Table	21 A

**332 - Tariff Table 16**

Length = 208, coding = alphanumerical

The element Tariff Table 16 consists of the following sub-elements:

No.	Element	L + C
328	Tariff Table	13 A
328	Tariff Table	13 A
328	Tariff Table	13 A
328	Tariff Table	13 A
328	Tariff Table	13 A
328	Tariff Table	13 A
328	Tariff Table	13 A
328	Tariff Table	13 A
328	Tariff Table	13 A
328	Tariff Table	13 A
328	Tariff Table	13 A
328	Tariff Table	13 A
328	Tariff Table	13 A
328	Tariff Table	13 A
328	Tariff Table	13 A
328	Tariff Table	13 A
328	Tariff Table	13 A
328	Tariff Table	13 A
328	Tariff Table	13 A
328	Tariff Table	13 A

**Different definition when Application Version = 1 in Element 9**

Length = 336, coding = alphanumerical

The element Tariff Table 16 consists of the following sub-elements:

No.	Element	L + C
328	Tariff Table	21 A
328	Tariff Table	21 A
328	Tariff Table	21 A

328	Tariff Table	21 A
328	Tariff Table	21 A
328	Tariff Table	21 A
328	Tariff Table	21 A
328	Tariff Table	21 A
328	Tariff Table	21 A
328	Tariff Table	21 A
328	Tariff Table	21 A
328	Tariff Table	21 A
328	Tariff Table	21 A
328	Tariff Table	21 A
328	Tariff Table	21 A
328	Tariff Table	21 A
328	Tariff Table	21 A
328	Tariff Table	21 A

**333 - Tariff code 4 digits**

Length = 4, coding = alphanumerical

Possible values:

" " = Not significant (blanks)

0000-9999 = UIC tariff code

**334 - 339 - Not used**

**340 - Price Table**

Length = 44 coding = alphanumerical

Each element in the Price Table consists of the following sub-elements:

No.	Element	L + C
308	Service Level – Tariff Link	4 A
333	Tariff code	4 A
52 F	Amount	7 N
348	Price Scope	2 N
347	Price Stability	2 N
350	Tariff Flexibility	1 A
67	Type of Price	1 N
nnn	For future use	3 A
349	Tariff Description	20 A

The element “for future use” is included to be able to extend the function in future. The content of this value must be ignored within the systems.

### 341 - Price Table2

Length = 2 x **Error! Reference source not found.**, coding = alphanumerical

The element Price Table 2 consists of the following sub-elements:

No.	Element	L + C
340	Price Table	<b>Error</b>
340	Price Table	<b>!</b>

### 342 - Price Table4

Length = 4 x **Error! Reference source not found.**, coding = alphanumerical

The element Price Table 4 consists of the following sub-elements:

No.	Element	L + C
341	Price Table 2	88 A
341	Price Table 2	88 A

### 343 - Price Table8

Length = 8 x **Error! Reference source not found.**, coding = alphanumerical

The element Price Table 8 consists of the following sub-elements:

No.	Element	L + C
342	Price Table 4	176 A
342	Price Table 4	176 A

### 344 - Price Table16

Length = 16 x **Error! Reference source not found.**, coding = alphanumerical

The element Price Table 16 consists of the following sub-elements:

No.	Element	L + C
343	Price Table 8	352 A
343	Price Table 8	352 A

**345 - Price Table32**

Length = 32 x **Error! Reference source not found.**, coding = alphanumerical

The element Price Table 32 consists of the following sub-elements:

No.	Element	L + C
344	Price Table 16	704 A
344	Price Table 16	704 A

**346 - Price Table64**

Length = 64 x **Error! Reference source not found.**, coding = alphanumerical

The element Price Table 64 consists of the following sub-elements:

No.	Element	L + C
345	Price Table 32	1408 A
345	Price Table 32	1408 A

### 347 - Price Stability

Length = 2, coding = alphanumerical

00 – no information

01 - transient, might change instantaneously

02 - stable for at least 1 hour

03 - stable for the current day in carrier systems time zone

### 348 - Price Scope

Length = 2, coding = alphanumerical

00 – no information

02 - Price per passenger

03 - Price per compartment

04 - Price for exact number of requested passengers only (nonlinear dependency on number of passengers)

### 349 – Tariff Description

Length = 20, coding = alphanumerical

Description text of a fare to be printed on the RCT-2 ticket in case the issuing railway does not provide a translated text.

### 350 – Tariff Flexibility

Length = 1, coding = alphanumerical

F fully flexible, can be exchanged without fees

S Semi flexible, can be exchanged with some restrictions

N Non flexible, exchange implies high fees

### 351 – Include Price Flag

Length = 1, coding = numerical

prices should be included in the availability reply

If the element is omitted the price tables and allocating railway elements must not be sent in the availability reply.

### 352 – Tariff Selection

Length = 32, coding = alphanumerical

The availability reply should give information on the listed tariffs only. The tariff code itself is numerical but empty elements must contain blanks.

No.	Element	L + C
333	Tariff code	4A
333	Tariff code	4A
333	Tariff code	4A
333	Tariff code	4A
333	Tariff code	4A
333	Tariff code	4A
333	Tariff code	4A
333	Tariff code	4A

## 4. Exchange protocol at application level using MQ to MQ

### 4.1. General

This transmission protocol can be used in case of communication via MQ series without an intermediate translator. It implies that reservation requests and information requests (e.g. availability requests and reservation-info only requests) use a limited expiry time for transmission whereas all other requests do not expire. It concerns only the issuing railway and the allocating railway applications.

The connection between the terminals and systems to which they are connected, are the exclusive responsibility of these systems.

An issuing system, which has sent a request to the allocating system for synchronising the system, uses the rules given in point 3.1, element 10 - page **Error! Bookmark not defined.** depending on the code received in the reply.

If a allocating system receives a synchronisation request before sending the reply to the request concerned, then in principle it should not reply to the original request.

## 4.2. Normal operation

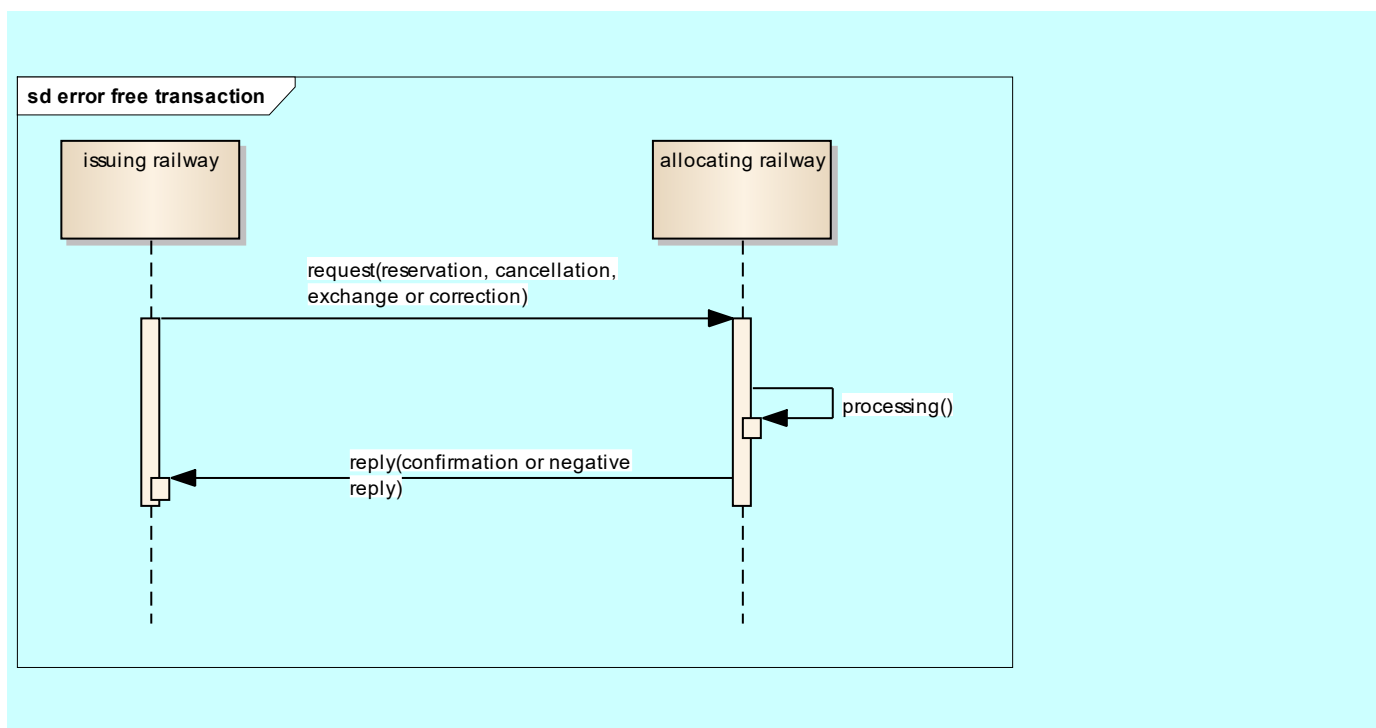

### 4.3. Defect in allocating system, before the reply can be sent

If after sending a request, the issuing system has not received a reply (from the allocating system) after a time "t", it sends a synchronising request to the allocating system.

After restoration of the service, the replying system analyses the situation and addresses the reply to the synchronising request using the reply codes given in point 3.1, element 10 - page **Error! Bookmark not defined..**

No synchronising request can be given for a synchronising request.

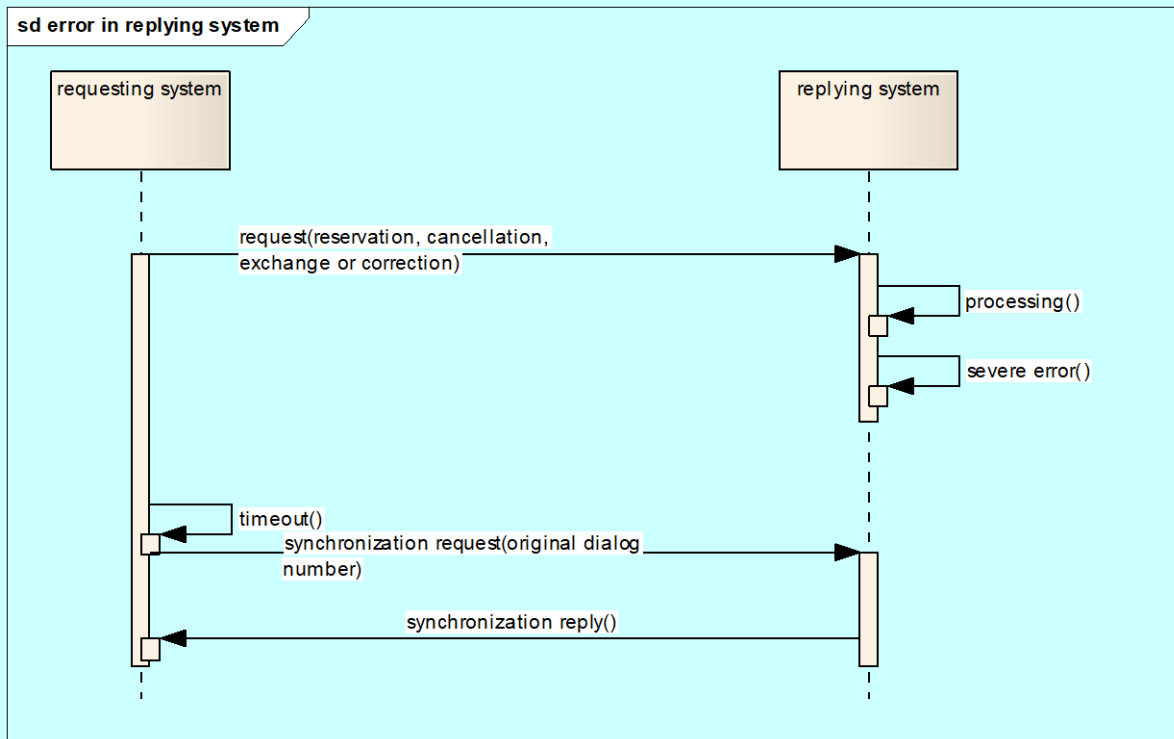



Corresponding state diagram at the issuing system in case of reservations:

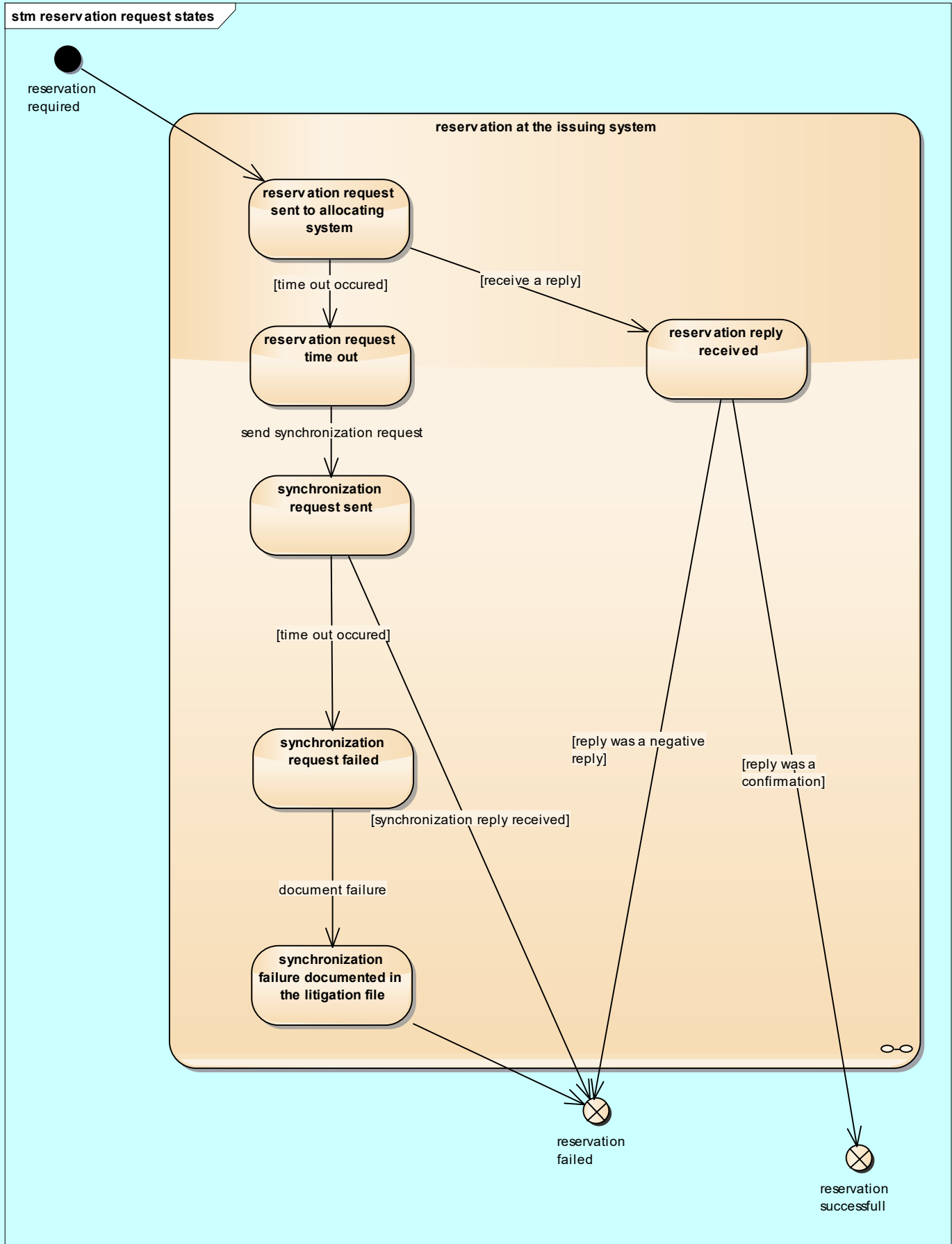

#### 4.4. Defect before the reply is received from the allocating system

When service is resumed the issuing system sends a synchronising request for the dialogue concerned to the allocating system.

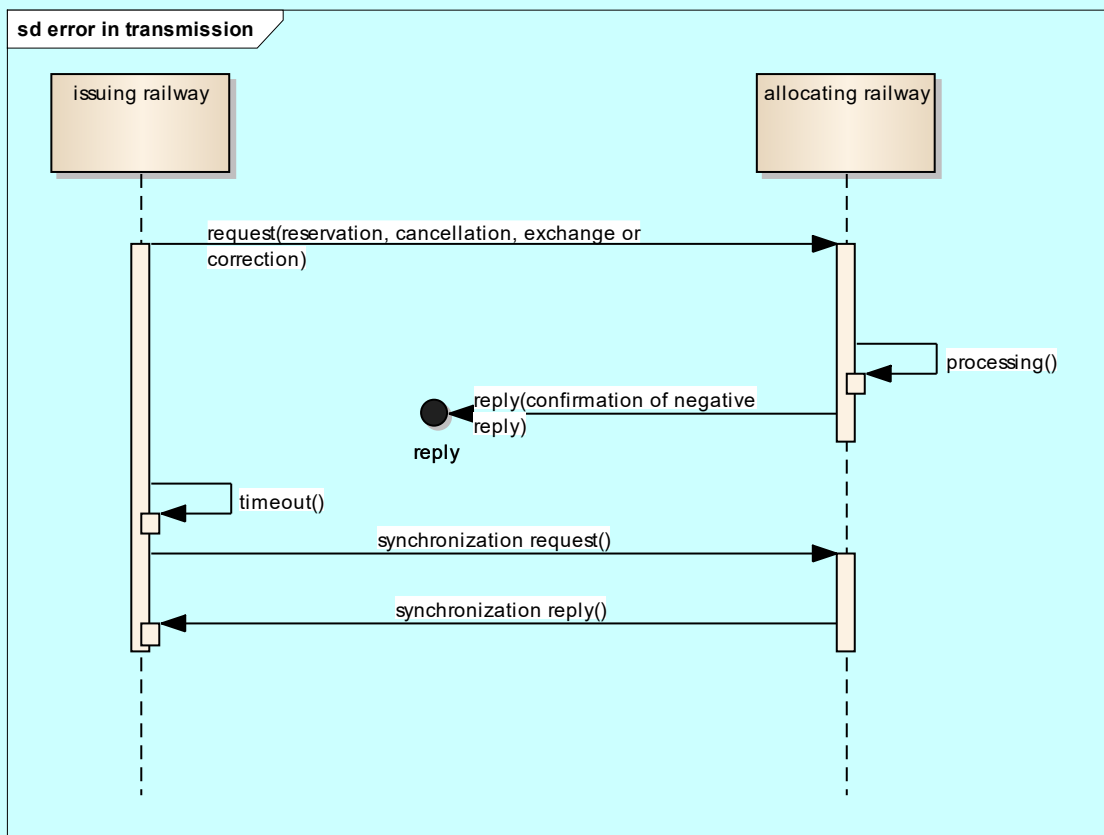

#### 4.5. Defect in issuing system after receipt of reply from the allocating system

When operation is resumed, if the reply involves a confirmation and if the document cannot be prepared, the issuing railway sends a correction request to the allocating railway. If this request results in a negative reply from the allocating railway, the issuing railway enters the request in the litigation file.

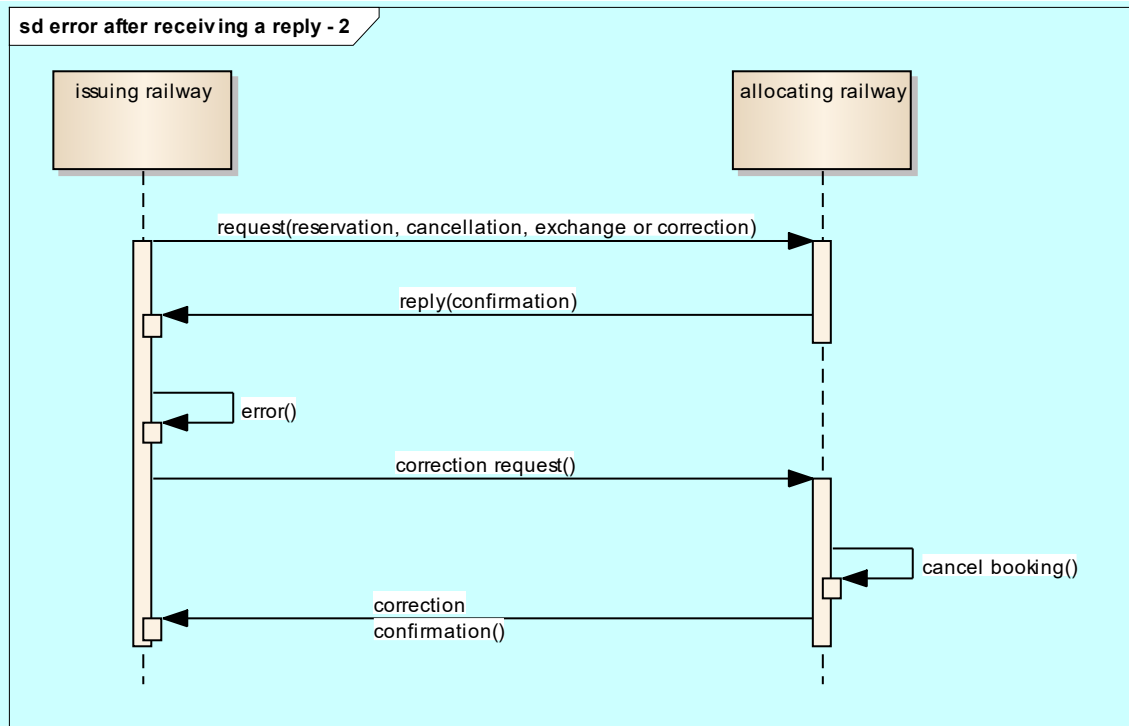

**4.6. The system is unable to use the confirmation received**

If, for any reason, the issuing system cannot send confirmation of an original request or confirmation of a partial cancellation to the requesting terminal, the issuing system sends a correction request to the allocating system.

In the case of a negative reply, the event shall be recorded in the litigation file.

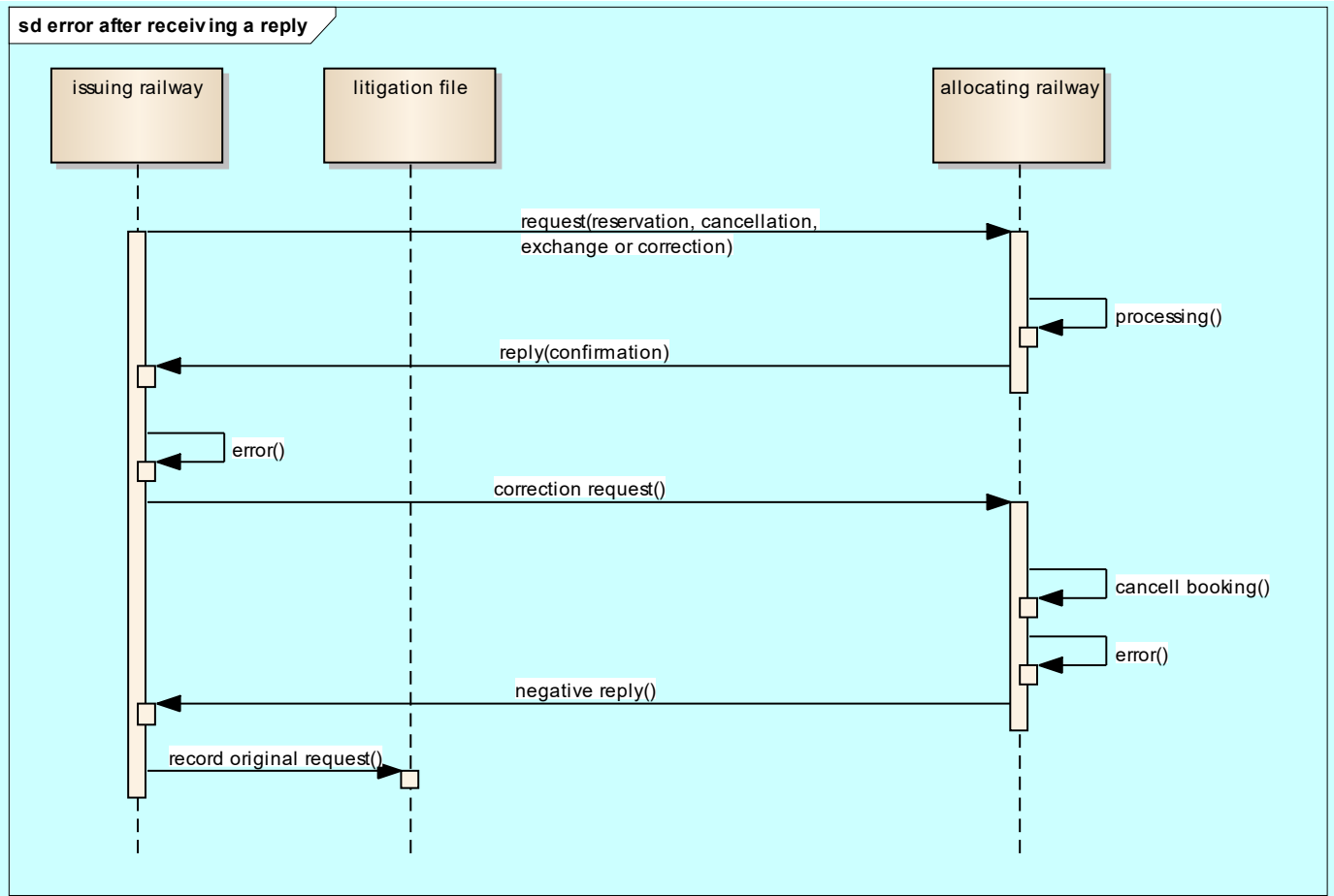

#### 4.7. Extended error recovery in case of Time Out on Reservation

This is the recommended error handling in case of a time out on a reservation request. The scenario extends the mandatory minimal behaviour specified in section “**Error! Reference source not found.**” and “**Error! Reference source not found.**”.

In case of a time out on a reservation request the issuing system must send a synchronization request to the allocating system.

Any time out should be documented in the litigation file.

The sending of the synchronization message should be repeated until a reply is received. The repetition should be continued for 72 hours but not beyond the departure date of the train. To avoid network traffic the request should not be repeated more than one time per hour.

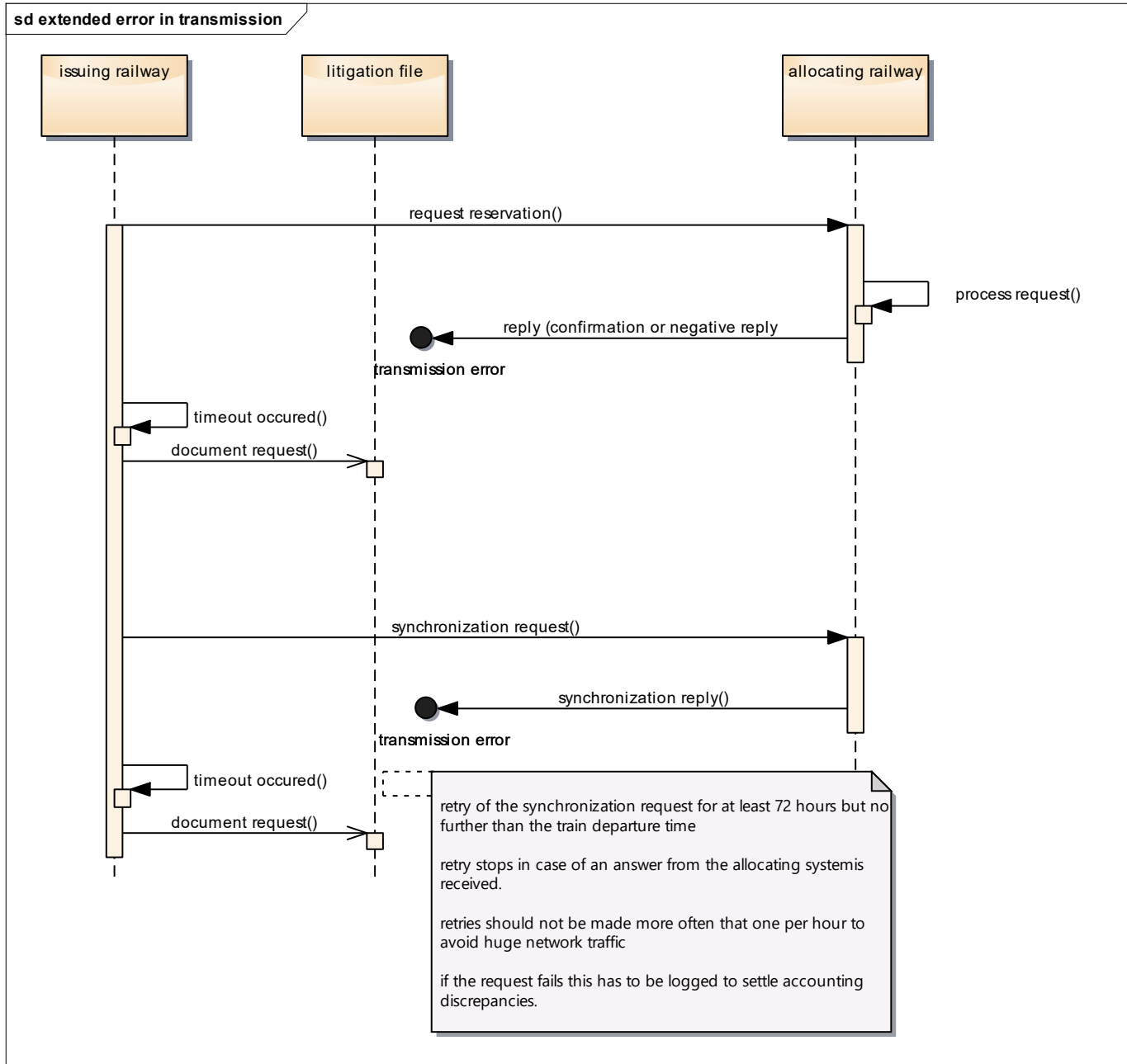

#### 4.8. Extended error recovery in case of Time Out on Cancellation

This is the recommended error handling in case of a time out on a cancellation or correction request. The scenario extends the mandatory minimal behaviour specified in section “**Error! Reference source not found.**” and “**Error! Reference source not found.**”.

In case of a time out on a cancellation or correction request the issuing system must repeat the request to the allocating system until the system received a reply different from a negative reply with an error code 110 and 111.

Any time out should be documented in the litigation file.

The sending of the cancellation or correction message should be repeated until a reply is received. The repetition should be continued for 72 hours but not beyond the departure date of the train. To avoid network traffic the request should not be repeated more than one time per hour.

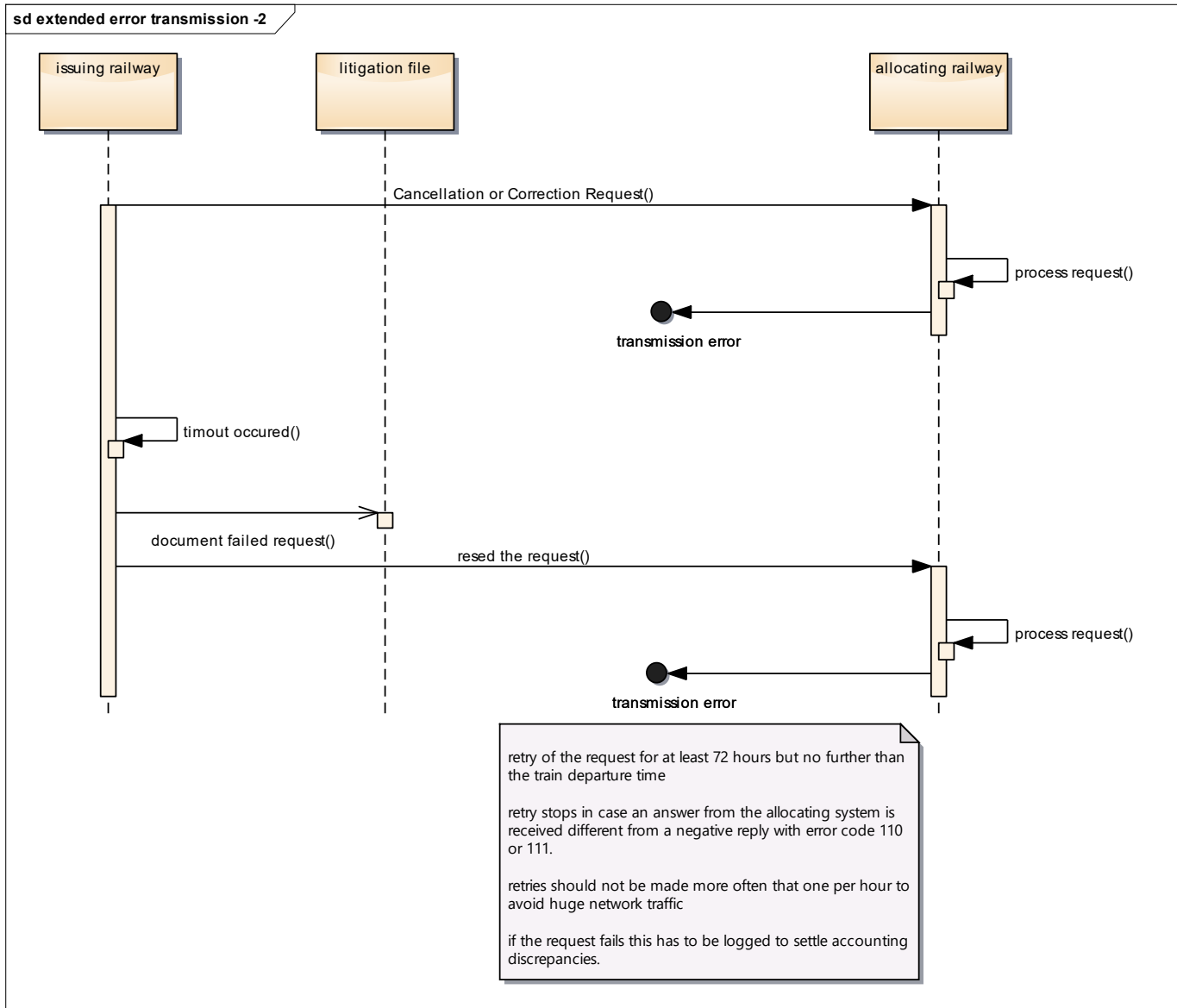

### 4.9. Repeated requests on Cancellation

The allocating railway can support different scenarios on repeated requests for a cancellation:

#### Scenario 1: Negative reply on already cancelled reservation

The allocating system returns a negative reply on a request for a reservation already cancelled.

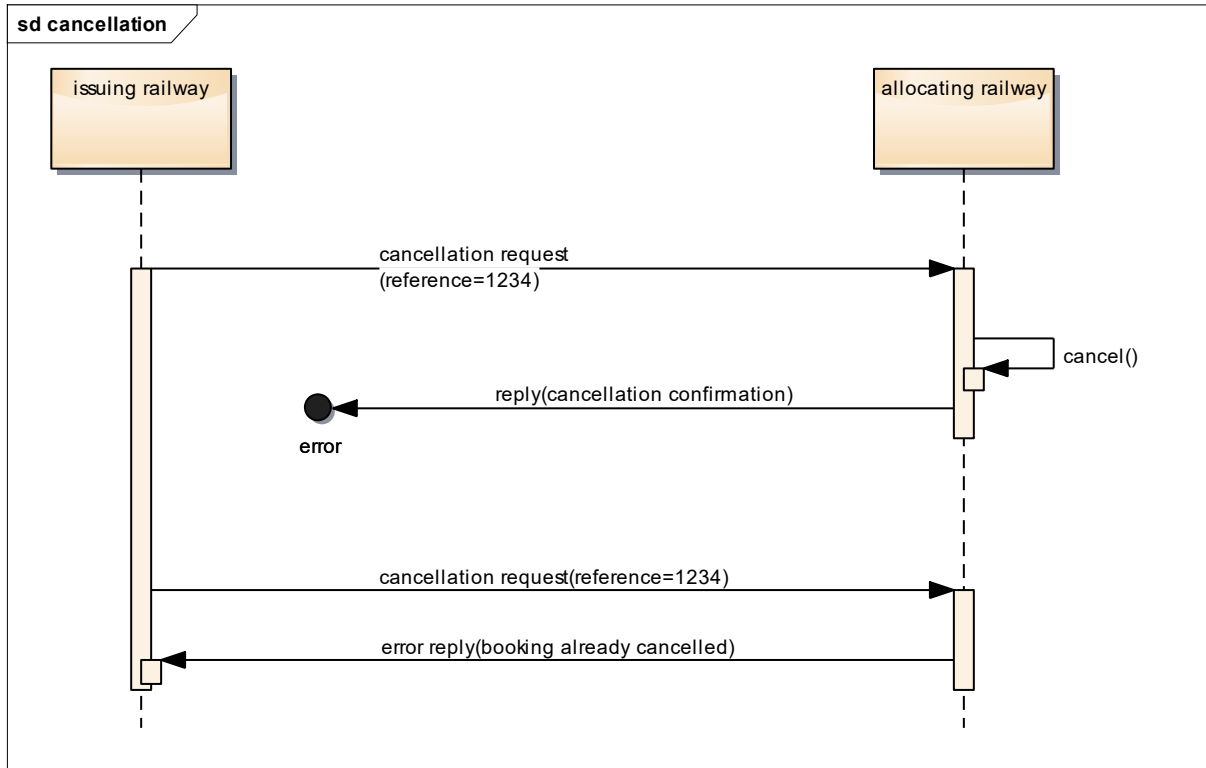

#### Scenario 2: Repeated reply on already cancelled reservation

The allocating system returns a repeated confirmation of the cancellation indicating the original cancelling railway and the original cancellation date to indicate that this confirmation has already been sent.

The issuing system must ensure the refund is given to the customer only one time. Thus it has to check whether the cancellation confirmation had already been forwarded to the customer or not.

In case the cancellation was originally made by another issuer no refund should be given to the customer without ensuring that there has not been a refund yet.

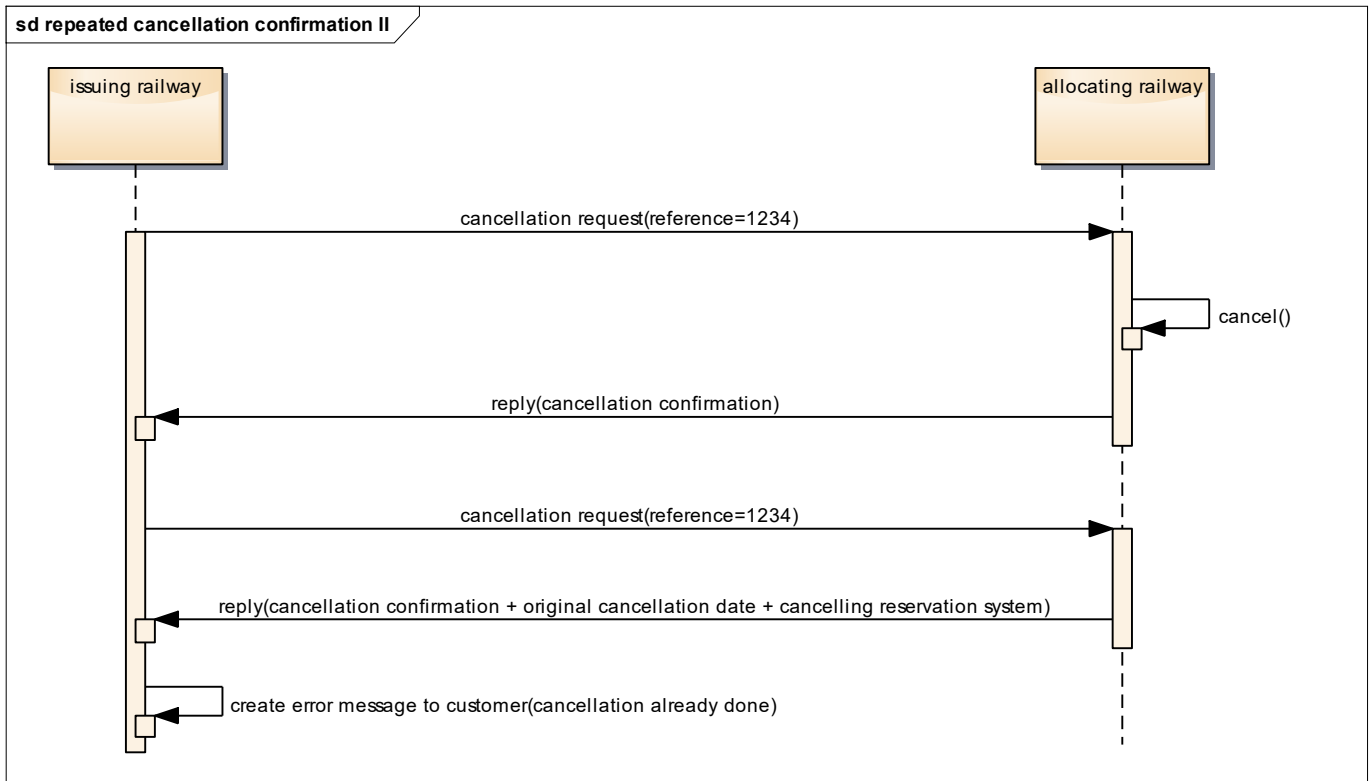
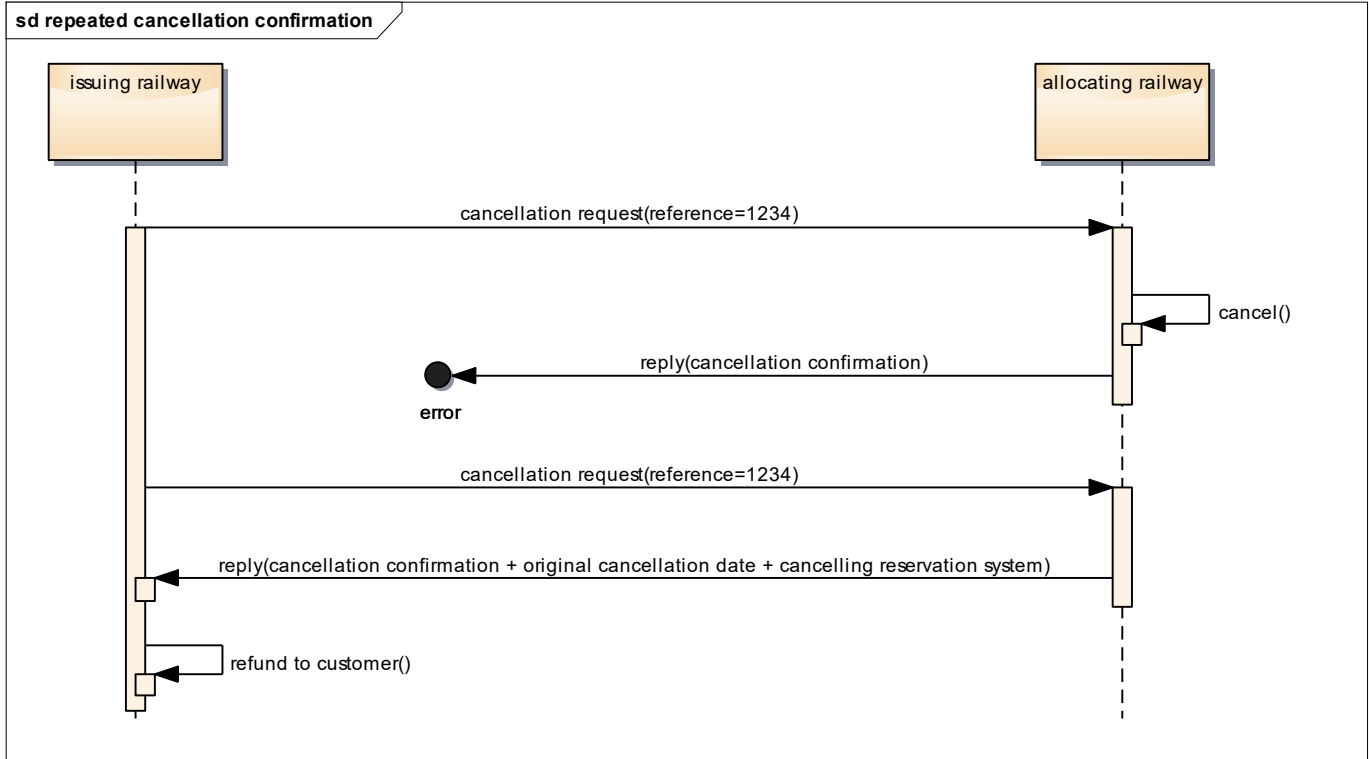

## 5. Principal Binary Message Structure



## 5.1. Definitions

### 5.1.1. Element

An element (basic element) is an indivisible item of data (for example, the code for a year, a station or a railway).

### 5.1.2. Group of elements

A group of elements is the combination of several elements to form another item of data belonging to a specific phrase (for example: the year + the month + the day, forming "the date").

### 5.1.3. Phrase

There are two kinds of phrase:

The standard phrase is a combination of elements and/or groups of elements forming a logical whole from the point of view of a function to be performed (for example: for charging, a phrase is formed with the general data of the consignment note, a phrase with the route data, a phrase with the wagon data for each wagon in the consignment, a phrase with the charging data for each wagon);

Each phrase has an identifier made up of 9 8-bit bytes.

An element (or group of elements) is optional when it need not necessarily be included in the phrase. Its absence is only revealed by the position zero of a bit in the topographical label. When it is absent, no position is therefore occupied by this element (or group of elements) in the sequence of data making up the phrase.

However, for applications of the "dialogue" type (for example, reservation of accommodation), where the "Response time" factor and the simultaneous processing of combined phrases are decisive factors, it may prove necessary to regard a message consisting of several phrases as the unit of data transmitted.

A message is made up of several phrases, consisting of two types:

- a "Header" phrase which is mandatory
- "Application text" phrases

### 5.1.4. Message

A message is a form of communication which makes it possible to perform a function, and which forms part of a more or less integrated system for international freight, passenger and baggage traffic as well as documentary research.

A message may be made up of one or more phrases: since the phrase - and not the message - is the unit of data transmitted, link elements must be incorporated in the phrases to enable them to be linked together and to reassemble the message.

## 5.2. Messages

### 5.2.1. Identification of messages

Messages may consist of phrases from various sources, and it is therefore not necessary to identify the messages by specific codes. A phrase, however, is an indivisible entity, and therefore requires a strict and standardised form of identification.

### 5.2.2. Phrase identifier

The phrase identifier is independent of the data exchange mode and is systematically made up of 9 bytes.

It is sub-divided into 3 parts: the identity, the version code, the topographical label.

### 5.2.3. Identity of the phrase

The identity of the phrase consists of 4 digits. The first two digits from the left represent the application number. The application number for the reservation application is « 01 » The next two digits contain the number of the phrase within the application.

### 5.2.4. Version code

The version code is expressed by 1 digit. It is used to differentiate between versions of the same phrase if these versions differ only slightly from each other.

### 5.2.5. Topographical label

The topographical label contains information showing the difference between the content of the phrase exchanged between two computers and that of the standard phrase, since the latter contains some items of information which may be unnecessary or may not be available at the time the phrase is formed.

This label consists of 32 bits, which is equivalent to 4 bytes, and is used to indicate the presence (bit with the value 1) or absence (bit with the value 0) of a maximum of 32 optional elements (or groups of elements) in a phrase. It is therefore merely a mask indicating the composition of the phrase transmitted, and thus makes it possible to process phrases of variable length easily.

Superfluous bits systematically assume the value 0.

For free-format phrases, the 4 bytes in question indicate the length of the phrase by giving the (decimal) number of characters in the phrase.

#### 5.2.6. Phrase structure

The structure of a phrase remains unalterable, irrespective of the destination of the phrase:

- the identifier:
  - identity ;
  - version code;
  - topographical label;
  
- compulsory elements and/or groups of elements;
  
- optional elements and/or groups of elements.

This order must be strictly observed.

An element (or group of elements) is compulsory when a fixed position is reserved for it in the layout of the phrase. The absence of a value for this element (or group of elements) is therefore revealed in the phrase by a number of blank positions equal to the number of characters stipulated for it.

### 5.3. Example of phrases to be transmitted

#### 5.3.1. Phrases with compulsory and optional elements

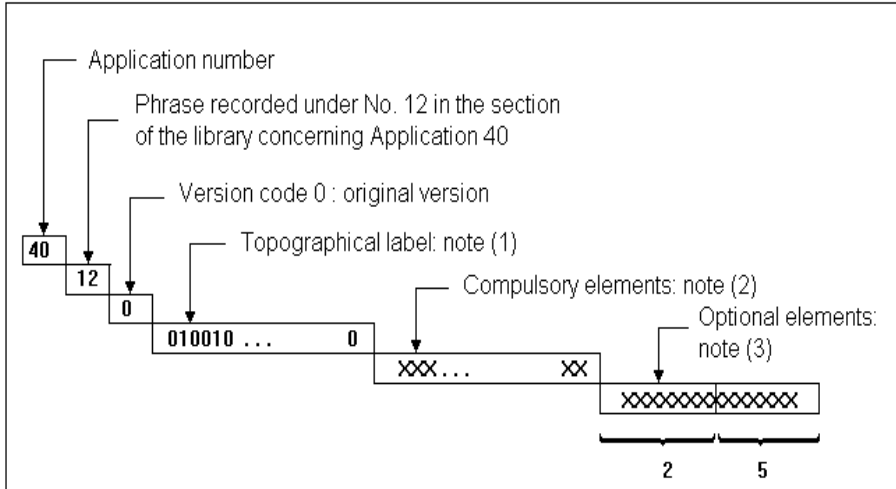

**Note (1):**

The topographical label indicates in binary form that for phrase no.12, only the optional elements 2 and 5 have been selected for transmission. Therefore, in the topographical label, bits 2 and 5 have the value 1 and the other 30 bits have the value 0.

**Note (2):**

The compulsory elements in phrase 12 shall be transmitted in full; they are recorded in the relevant field.

**Note (3)**

Of the n optional elements ( $n_{max} = 32$ ) in phrase 12, only elements 2 and 5 are chosen for transmission, they are recorded in the relevant field in increasing order according to their serial number in the library.

5.3.2. Phrases which contain compulsory elements only

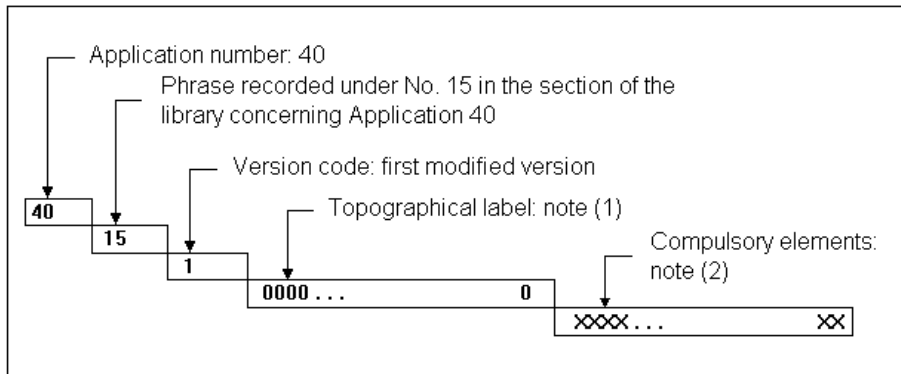

**Note (1):**

Since there are no optional elements available for phrase 15, the binary code in the topographical label contains only 0s.

**Note (2):**

The field of data contains only the compulsory elements of phrase 15.

5.3.3. Phrases which contain optional elements only

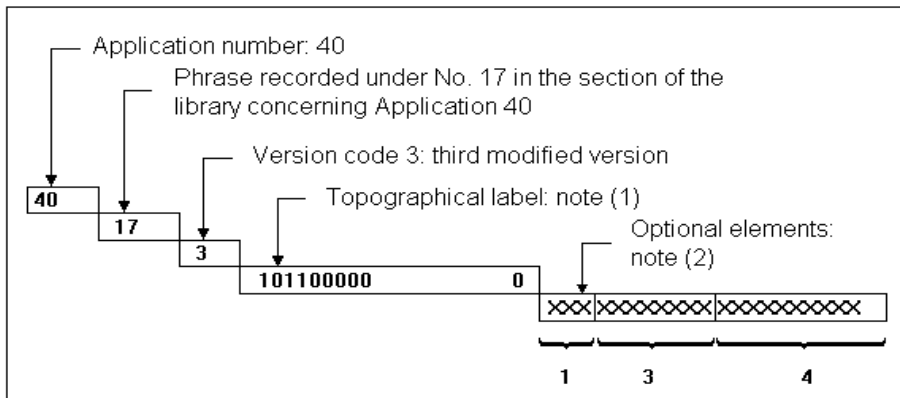

**Note (1):**

Phrase 17 contains only elements which are optional in the library. The topographical label indicates that only elements nos. 1, 3 and 4 are transmitted. The corresponding bits have the value 1.

**Note (2):**

The optional elements in phrase 17 chosen for transmission are recorded in the field of data in increasing order according to their serial number in the library.

## 5.4. Reservation messages

### 5.4.1. Structure

A message is made up of several phrases, consisting of two types:

- a "Header" phrase which is mandatory
- "Application text" phrases

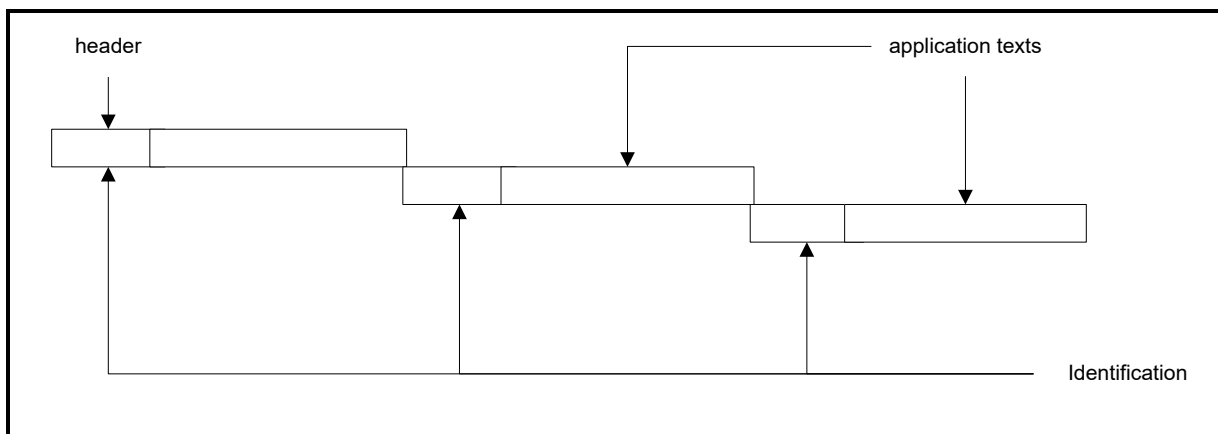

### 5.4.2. Header phrase

This enables the message to be identified and contains the information:

- required for the application level exchange procedure,
- denoting the function to be performed,
- clarifying whether it is an operational or test message,
- specifying the application version.

### 5.4.3. Application text phrase

This contains the information required for processing based on the type of message and service. The types of service that can be provided by reservation messages are:

- reservation (request and reply),
- cancellation (request and reply),
- correction (request and reply) of data in the allocating RS due to an anomaly during processing or transmission,
- messages in 918E format.

Each phrase is characterised by a prefix.

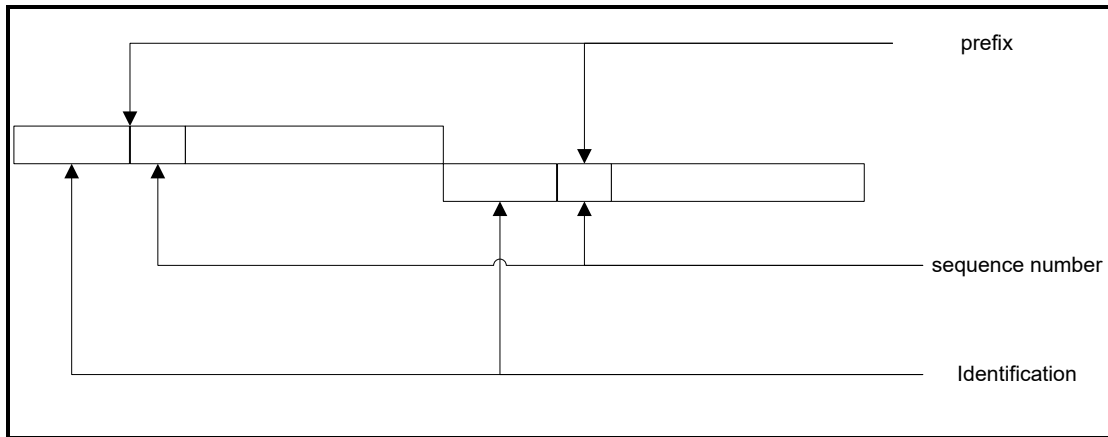

If a message contains several "Application text" phrases, they must be linked by the prefix serial number. The phrases must be numbered in decreasing order and end with 1. If there is only one "Application text" phrase, the serial number shall be 1.

#### 5.4.4. Sequencing between the Application text phrases

It may sometimes be necessary to establish a link between the "Application text" phrases:

- for a request and the corresponding reply,
- for a reservation confirmation and the correction message.

For correction messages, the initial dialogue number enable the link to be established.

Regarding negative replies and alternative proposals, the sequencing is established by including the "serial number" value of the request in the "request number" of the reply(ies).

If a reply concerns the entire request message, the element "request number" is absent.

5.4.5. Sequencing request/negative reply or alternative proposal

Solution 1

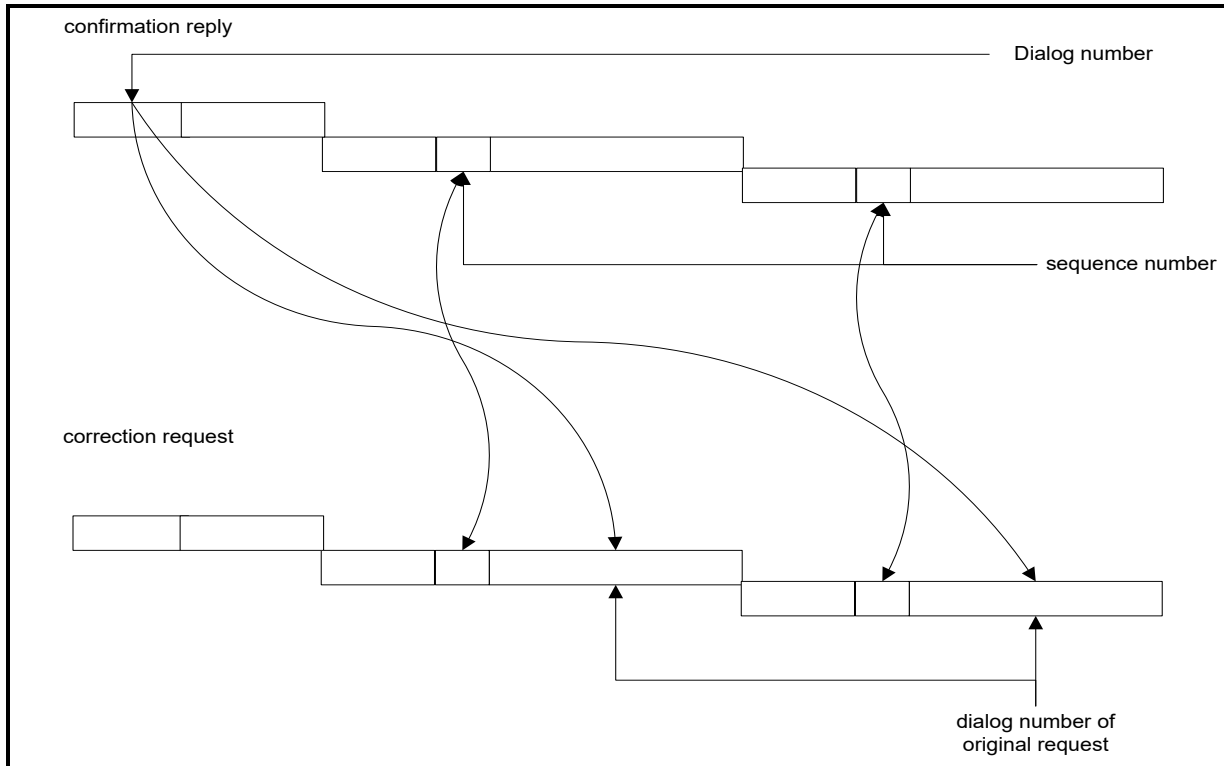

Solution 2:

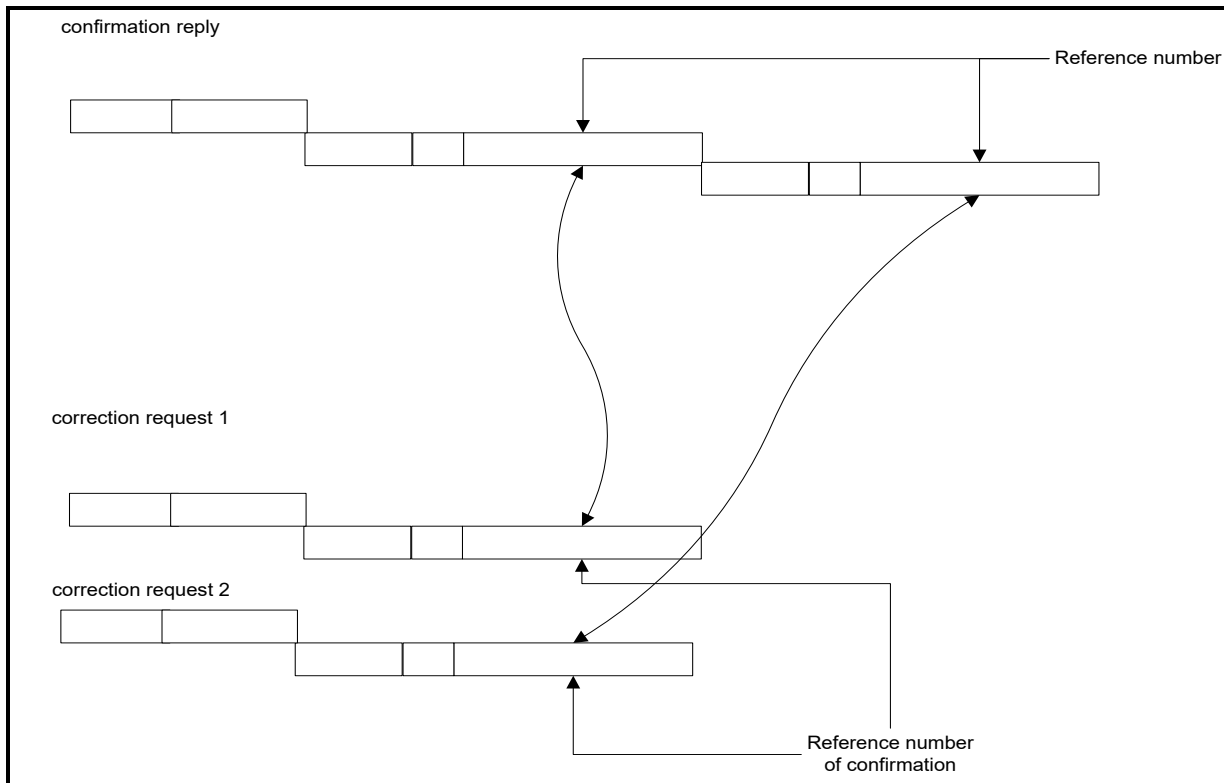



5.4.6. Sequencing request/global negative reply

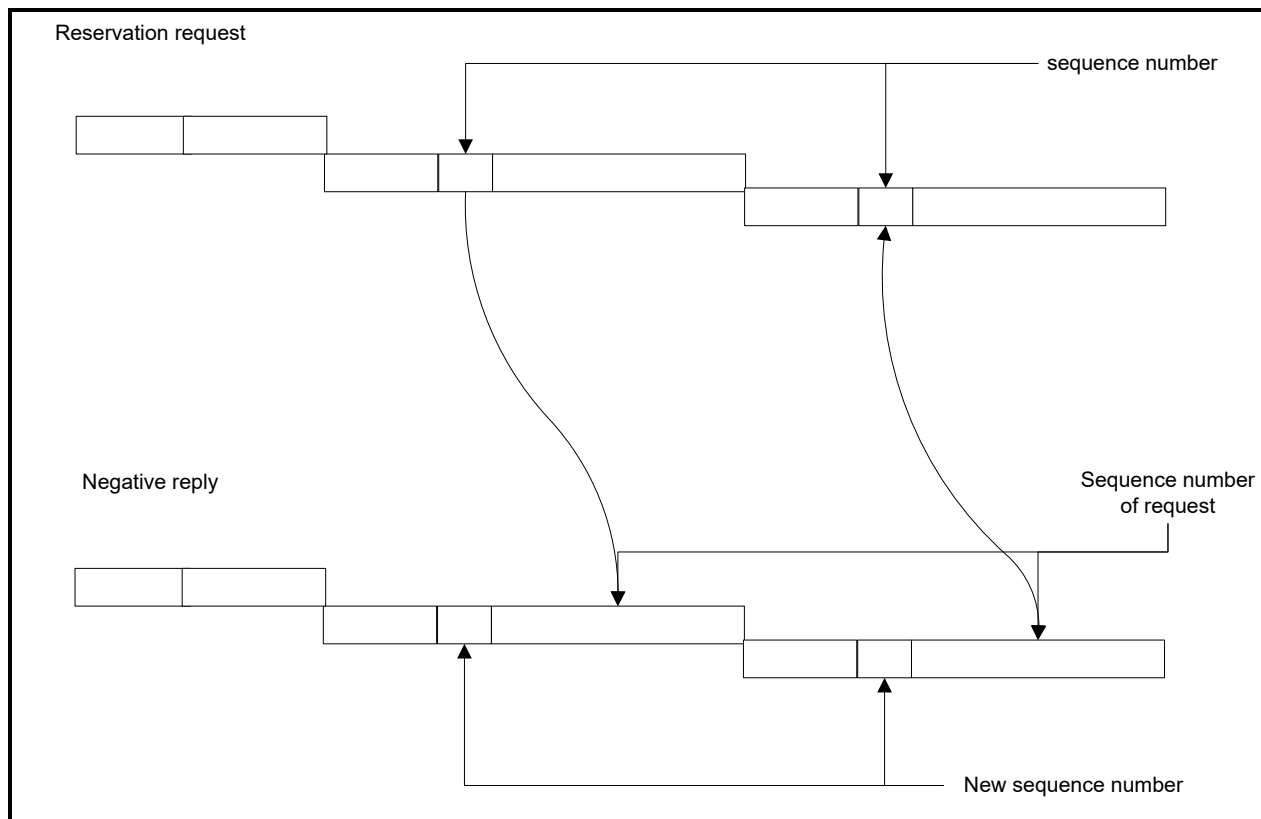

In case of a negative reply not related to a particular application text, the reply does not contain one of the old sequence numbers.

### 5.5. Extended reservation messages 918E

The extended binary message definition 918<sup>E</sup> includes an additional element 18 – “type of text” in the prefix of each application text. This element specifies the application text provided. The 2 digit code allows to use the application texts from the old 918 binary format as well as additional application texts for availability information and the DMD.

A 918<sup>E</sup> message contains at least 2 application texts in the message, the first of which is a DMD (see point 2.14 - page **Error! Bookmark not defined.**).

In a 918E message all application texts must use the 918<sup>E</sup> format.

#### 5.5.1. Identification of 918E messages

A 918E message is identified by the value 8 in element type of request.

In case of a 918E – message with a DMD and negative replies the type of request or reply of the DMD should also be value 8 (=negative reply).

#### 5.5.2. Sequencing of application texts in 918<sup>E</sup> messages

The application texts of a 918E message contain a text group identifier. It identifies a group with the first digit and numbers the application texts of the group in the second digit subsequently.

