

ERTMS/ETCS
Train Interface FFFIS
REF : SUBSET-119 ISSUE : 4.0.0 DATE : 2023-07-05

Company	Technical Approval	Management approval
ALSTOM		
AZD		
CAF		
FAIVELEY TRANSPORT		
HITACHI RAIL STS		
KNORR-BREMSE		
MERMEC		
SIEMENS		
THALES		
TÜV		
VOITH TURBO		
VOSSLOH		

MODIFICATION HISTORY

Version	Date	Modification / Description	Editor
0.1.0	05-09-2013	Submission to sector for review	Armin Weiss
0.1.1	08-10-2013	Review according open SG comments 3.2.1.3.4 added acc. Telco 4.3.2.1 deleted acc. Telco Table 4-1 Missing references added 5.2.6.2 Names corrected (T_...) 5.3.2.2.2 Reference added 5.3.3.7 Reference added 5.3.8.7 Reference added 5.3.13 added 5.5.2.4.1.5 extended due to specific signals for special brake status 5.5.2.4.3.2f adapted due to specific signals for special brake status	Armin Weiss
0.1.2	11.10.2013	changes see review sheet Subset-119v010_review sheet_ERA_091013_SG v2.doc	Armin Weiss
0.1.3	24.10.2013	changes see review sheet Subset-119v010_review sheet_ERA_091013_SG v2.doc	Armin Weiss
0.1.4	29.10.2013	changes see review sheet Subset-119v010_review sheet_ERA_091013_SG v3.doc	JP Gilbert
0.1.5	12.11.2013	changes see review sheet Subset-119v010_review sheet_ERA_091013_SG v3.doc 5.1.1.2.1. Explanation for invalid signal values adapted.	Armin Weiss
0.1.6	9.12.2013	BT Review	Armin Weiss
0.1.7	10.01.2014	TI acronym added	JP Gilbert
0.1.8	17.01.2014	Review meeting in Berlin	Armin Weiss
0.1.9	11.02.2014	Review of Live meeting main brake pipe, main pipe -> brake pipe STM order chapters referring to related trackside order chapters	Jean-Pierre Gilbert, Armin Weiss
0.1.9.1	12.02.2014	Changes after agreement with SG: HMI pictograms removed from pictures	Armin Weiss

		Area signals in variant 2 removed Variant 1 for special brake inhibition introduced	
0.1.10	27.02.2014	Changes acc. Review meeting in Munich	Armin Weiss
0.1.11	04.03.2014	Changes acc. Review confcall March, 4 th	Armin Weiss
0.1.12	25.09.2014	Changes according review Unisig_SG_COM_SS-119v0 1 11_1 0	J.P. Gilbert
0.1.13	16.10.2014	For consistency with Subset-034 and Subset-026 removed Test in progress, Emergency Brake Command Status, EB Command Feedback, and the clause 5.4.1.2.2. Replaced the contents of the following with “to be harmonized” (because the solutions are not part of MR1): Management of Track Conditions including Open MCB and Traction Current Cut-Off, and train data information. Added specifications for STM orders. Deleted TCO Solution 1.	F. Bitsch
1.0.1	20.06.2016	Reworked the document due to solution of the relevant B3R2 CRs CR0239, CR0539, and CR1163 and consideration of SG comments with agreed corrections.	F. Bitsch
1.0.2	27.07.2016	Correction that change marks are only related to the last official version 0.1.13 and not to pre-versions of 1.0.1. Change mark authors harmonised to “UNISIG”. Consideration of SG comments with agreed corrections.	F. Bitsch
1.0.3	25.10.2017	Reworked according to the agreements achieved for CR0539 and CR1163 in 10/2016. Consideration of agreed review comments.	F. Bitsch
1.0.4	20.01.2018	Incorporation of the answers for review comments	F. Bitsch
1.0.5	07.05.2018	Incorporation of the answers for review comments and decisions from the phone conferences 06.03.2018 and 13.4.2018	F. Bitsch
1.0.6	26.05.2018	Incorporation of the decisions from the phone conferences 23. And 24.05.2018	F. Bitsch
1.0.7	14.06.2018	Changes according to discussed review comments received for versions 1.0.4-1.0.6	F. Bitsch

1.0.8	07.09.2018	Rework of train data topic (especially chapter 5.5) based on the discussion on purpose of train data and principles of train data entry from external source	F. Bitsch
1.0.9	21.10.2018	Changes for the train data topic (especially chapter 5.5) due to the discussed review comments. Added new clause 3.3.1.1.	F. Bitsch
1.0.10	11.01.2019	Further changes for chapter 5.5 due to the discussed review comments. 1.1.1.3 re-stored to the formulation of version 1.0.5 due to discussions with UNISIG SC.	F. Bitsch
1.0.11	12.04.2019	Changes according to discussed review comments received for versions 1.0.10	F. Bitsch
1.0.12	04.06.2019	Changes according to decisions of the telco 24.05.2019 for Special Brake Status, Brake Position, §3.3.1.1, and §5.3.11.1.2.1	F. Bitsch
1.0.13	06.06.2019	Changes according to decisions of the telco 06.06.2019 in 4.3.1.7, 4.3.7, 5.3.1.12, and 5.3.7	F. Bitsch
1.0.14	07.06.2019	Editorial changes. Changes in the name of OBU_TR_SP_Height(K)_BitX for indication of bit0 – bit 4	F. Bitsch
1.0.15	25.06.2019	Editorial changes.	F. Bitsch
1.1.0	29.09.2020	Baseline 3 2 nd release version	F. Bitsch
1.1.1	19.07.2020	Deletion of parts to be moved to SS-143 and additions for consistency with SS-143	F. Bitsch
1.1.2	21.09.2020	Changes according to the review meeting 09.09.2020	F. Bitsch
1.1.3	28.09.2020	Introduction of Train Integrity according to CR940 solution	F. Bitsch
1.1.4	31.10.2020	Changes according to the received comments for changes related to Train Integrity	F. Bitsch
1.1.5	02.11.2020	Changes according to the review meeting in the UNIFE MG On-board Architecture at 02.11.2020	F. Bitsch
1.1.6	09.11.2020	Changes according to new comments.	F. Bitsch
1.1.7	16.11.2020	Changes according to the review meeting in the UNIFE MG On-board Architecture at 16.11.2020	F. Bitsch
1.1.8	23.11.2020	Changes according to the review meeting in the UNIFE MG On-board Architecture at 23.11.2020	F. Bitsch

1.2.0	24.11.2020	Draft version for distribution in the ERA TWG ARCHI	F. Bitsch
1.2.1	14.12.2020	Introduction of the AD output signal compliant with CR1238 solution	F. Bitsch
1.2.2	05.05.2021	Changes according to the discussed review comments in the ERA TWG ARCHI 18.02.2021 and the follow-up meeting at 05.05.2021	F. Bitsch
1.2.3	26.07.2021	Changes according to further received comments in the UNIFE MG On-board Architecture and ERA comment no. 9	F. Bitsch
1.2.4	06.09.2021	Changes according to further received comments in the UNIFE MG On-board Architecture	F. Bitsch
1.2.5	02.11.2021	Added Appendix A; changes based on safety analysis; consideration of CR solutions for CR1374, CR1383, CR1290, and CR1346	F. Bitsch
1.2.6	15.11.2021	Changes due to review comments in the UNIFE MG On-board Architecture.	F. Bitsch
1.2.7	11.01.2022	Changes due to comments from OCORA.	F. Bitsch
1.2.8	18.01.2022	Changes due to follow-up comments from OCORA.	F. Bitsch
1.2.9	22.01.2022	Editorial changes for the submission to EECT	F. Bitsch
1.2.10	25.04.2022	Changes due to comments from OCORA and EECT and due to alignment of terms with TSI Loc&Pas	F. Bitsch
1.2.11	27.05.2022	Changes due to EECT 05/05/22; deletion of "Train Type" signal according to the proposed changes to Subset-034; §5.3.11.1.1 extended for STM	F. Bitsch
1.2.12	28.06.2022	Changes due to EECT 09/06/22; deletion of "Tilting Status" signal; references to S-120 are aligned with its update; clarification for SDTv2 parameters; Remote Shunting due to changed safety analysis	F. Bitsch
1.2.13	09.11.2022	Alignment with the CR solution for CR1367	F. Bitsch
1.2.14	07.01.2023	Changes due to comments from EUG/OCORA and ERA and update of the CR1367 solution.	F. Bitsch
3.9.2	15.02.2023	Formal update for the B4R1 pre-release version	F. Bitsch
4.0.0	05.07.2023	Baseline 4 1 st release version	F. Bitsch



TABLE OF CONTENTS

1. INTRODUCTION	13
1.1 Scope and Purpose	13
1.2 Document Structure.....	15
1.3 References	15
1.4 Terms and Abbreviations	16
2. TRAIN INTERFACE.....	19
2.1 Architecture	19
2.2 Naming Conventions	22
2.2.1 Signals on the Hard-wired Interface.....	22
2.2.2 Signals on the Serial Interface	24
3. GENERAL REQUIREMENTS FOR THE HARD-WIRED INTERFACE.....	27
3.1 General Requirements.....	27
3.2 Reference Input and Output Architecture (RIO)	27
3.3 Boolean OBU Inputs	28
3.4 Boolean OBU Outputs	29
4. GENERAL REQUIREMENTS FOR THE SERIAL INTERFACE.....	31
4.1 General Requirements.....	31
4.2 Serial Architectures.....	31
4.2.1 General.....	31
4.2.2 Architecture a)	31
4.2.3 Architecture b)	33
4.3 Coding.....	34
4.3.1 General.....	34
4.3.2 Serial Interface Signals.....	36
4.3.3 TR Packet 1.....	51
4.3.4 TR Packet 2.....	53
4.3.5 TR Packet 3.....	55
4.3.6 Variables for Generic Packet Structures	56
4.3.7 OBU Packet 1.....	61
4.3.8 OBU Station Platform (OBU Packet 2).....	64
4.3.9 OBU Packet 3.....	67
4.3.10 OBU Packet 4.....	69
4.3.11 OBU Packet 5.....	70



4.3.12	OBU Packet 6.....	72
4.3.13	OBU Packet 7.....	73
4.4	MVB	75
4.4.1	General.....	75
4.4.2	Data Properties and Application of the Safety Protocol.....	75
4.5	CAN.....	78
4.5.1	General.....	78
4.5.2	Data Properties and Application of the Safety Protocol.....	79
4.6	ECN.....	79
4.6.1	General.....	79
4.6.2	Data Properties and Application of the Safety Protocol.....	80
5.	REQUIREMENTS FOR THE SIGNALS TO BE EXCHANGED AT THE TRAIN INTERFACE	84
5.1	Mode Control	84
5.1.1	Sleeping	84
5.1.2	Passive Shunting.....	84
5.1.3	Non Leading	85
5.1.4	Isolation	85
5.1.5	Automatic Driving	86
5.1.6	Remote Shunting.....	86
5.2	Signals for the Control of Brakes	87
5.2.1	Service Brake Command.....	87
5.2.2	Brake Pressure.....	87
5.2.3	Emergency Brake Interface	88
5.2.4	Special Brake Inhibition Area – Trackside Orders.....	94
5.2.5	Special Brake Inhibition Area – STM Orders.....	95
5.2.6	Special Brake Status	97
5.2.7	Additional Brake Status	99
5.3	Control of Train Functions.....	99
5.3.1	General.....	99
5.3.2	Change of Traction System	102
5.3.3	Powerless Section with Pantograph to be Lowered – Trackside orders	104
5.3.4	Pantograph – STM Orders.....	105
5.3.5	Air Tightness Area – Trackside orders.....	106
5.3.6	Air Tightness – STM Orders	107
5.3.7	Station Platform	108



5.3.8	Powerless Section with Main Power Switch to be Switched Off – Trackside Orders	111
5.3.9	Main Power Switch – STM Orders	113
5.3.10	Change of Allowed Current Consumption	113
5.3.11	Engine Orientation in Supervised Manoeuvre	115
5.3.12	Traction Cut-Off	116
5.4	Signals for Train Status Information	117
5.4.1	Cab Status	117
5.4.2	Direction Controller	117
5.4.3	Train Integrity	118
5.4.4	Traction Status	119
5.4.5	Set Speed	120
5.5	Train Data	121
5.5.1	General	121
5.5.2	Type of Train Data Entry	122
5.5.3	Overall Consist Length Information	123
5.5.4	Other Train Data Information	125
5.6	Additional Data	133
5.6.1	Train Running Number	133
5.7	National System Isolation	134
6.	CONFIGURATION MANAGEMENT	135
7.	APPENDIX A – PROFINET SIGNAL AND PACKET DEFINITIONS	138
7.1.1	TR Packet 1	138
7.1.2	TR Packet 2	140
7.1.3	TR Packet 3	142
7.1.4	OBU Packet 1	143
7.1.5	OBU Station Platform (OBU Packet 2)	145
7.1.6	OBU Packet 3	149
7.1.7	OBU Packet 4	150
7.1.8	OBU Packet 5	151
7.1.9	OBU Packet 6	153
7.1.10	OBU Packet 7	154



TABLE OF TABLES

Table 1-1 Cross references between Subset-034 and Subset-119	14
Table 1-2 Terms	16
Table 1-3 Abbreviations	18
Table 2-1 Reference to all functional I/O	22
Table 3-1 Definition of signal states	28
Table 3-2 Characteristics for OBU Boolean Inputs	29
Table 3-3 Characteristics for OBU Boolean outputs	30
Table 4-1 Generic Serial Interface Table.....	50
Table 4-2 Coding for Variables used for Generic Packet Structures.....	59
Table 4-3 Meaning of Track Condition Type Values.....	60
Table 5-1 Coding for enable Sleeping function.....	84
Table 5-2 Coding for Passive Shunting	84
Table 5-3 Coding for Non Leading	85
Table 5-4 Coding for Isolation (of ETCS)	85
Table 5-5 Coding for Automatic Driving	86
Table 5-6 Coding for Remote Shunting	86
Table 5-7 Coding for Service Brake command.....	87
Table 5-8 Coding for Brake Pressure	87
Table 5-9 Coding for EB1 and EB2 command (solutions 1 and 2).....	93
Table 5-10 Coding for EB1 and EB3 command (solution 3)	93
Table 5-11 Coding for Regenerative Brake Inhibit.....	95
Table 5-12 Coding for Magnetic Shoe Brake Inhibit	95
Table 5-13 Coding for Eddy Current Brake for Service Brake Inhibit.....	95
Table 5-14 Coding for Eddy Current Brake for Emergency Brake Inhibit.....	95
Table 5-15 Coding for Regenerative Brakes Inhibition command – STM Orders.....	96
Table 5-16 Coding for Magnetic Shoe Brake Inhibition command – STM Orders.....	96
Table 5-17 Coding for Eddy Current Brake for Service Brake Inhibition command – STM Orders...	96
Table 5-18 Coding for Eddy Current Brake for Emergency Brake Inhibition command – STM Orders	96



Table 5-19 Coding for Electro Pneumatic Brake Status	97
Table 5-20 Coding for Eddy Current Brake Status	97
Table 5-21 Coding for Regenerative Brake Status	98
Table 5-22 Coding for Magnetic Shoe Brake Status	98
Table 5-23 Coding of variables “OBU_TR_XXX_D_Entry” and “OBU_TR_XXX_D_Change”	101
Table 5-24 Coding of variables “OBU_TR_XXX_D_Exit”	101
Table 5-25 Coding for Change of Traction System	103
Table 5-26 Coding for Lower Pantograph Command	105
Table 5-27 Coding for Pantograph Command – STM Orders	106
Table 5-28 Coding for Air Tightness Area Command	107
Table 5-29 Coding for Air Tightness – STM Orders	107
Table 5-30 Coding for Station Platform	109
Table 5-31 Coding for passing a Powerless Section with Main Power Switch to be Switched Off .	113
Table 5-32 Coding for Main Power Switch – STM Orders	113
Table 5-33 Coding for Change of Allowed Current Consumption	114
Table 5-34 Coding for Engine Orientation in Supervised Manoeuvre	115
Table 5-35 Coding for Traction Cut Off	116
Table 5-36 Coding for Cab Status	117
Table 5-37 Coding for Direction Controller	118
Table 5-38 Coding for Train Integrity	119
Table 5-39 Coding for Traction Status (only for STM)	120
Table 5-40 Coding for Set Speed value	120
Table 5-41 Coding for Set Speed display	120
Table 5-42 Coding of variable Type of Train Configuration	122
Table 5-43 Coding for Type of Train Data Entry	122
Table 5-44 Coding for Overall Consist Length	125
Table 5-45 Coding of variable Brake Percentage	128
Table 5-46 Coding for Brake Position	129
Table 5-47 Coding of Traction System(s) Accepted by the Engine	132
Table 5-48 Coding for Train Fitted with Airtight System	133



Table 5-49 Coding for Train Running Number	133
Table 5-50 Coding for National System Isolated (in case the NTCx safety level requires only one signal).....	134
Table 5-51 Coding for National System Isolated (in case the NTCx safety level requires two signals)	134
Table 6-1 Configuration data related to the Train Interface	137



TABLE OF FIGURES

Figure 2-1 Hard-wired and serial links between vehicle and ERTMS/ETCS on-board equipment ...	19
Figure 3-1 Reference I/O pair	27
Figure 4-1 Architecture a)	32
Figure 4-2 Architecture b)	33
Figure 4-3 Safe Data Transmission via CAN.....	79
Figure 5-1 EB architecture example with electric safety loop	88
Figure 5-2 EB architecture example with brake pipe	89
Figure 5-3 EB architecture example with one EB line and a serial link	90
Figure 5-4 EB function, Solution 1: 2 EB lines.....	91
Figure 5-5 EB function, Solution 2: 2 EB lines.....	92
Figure 5-6 EB function, Solution 3: 1 EB line, serial interface.....	92
Figure 5-7 Passing a Special Brake Inhibition Area	94
Figure 5-8 Changing the traction system.....	103
Figure 5-9 Passing a Powerless Section with Pantograph to be Lowered.....	104
Figure 5-10 Passing an Air Tightness Area.....	106
Figure 5-11 Station Platform	111
Figure 5-12 Passing a Powerless Section with Main Power Switch to be Switched Off.....	112
Figure 5-13 Change of Allowed Current Consumption	114
Figure 5-14 Illustration of the term Engine Orientation	115
Figure 5-15 TCO function: 1 TCO line and a serial interface	116

1. INTRODUCTION

1.1 Scope and Purpose

1.1.1.1 This interface specification defines the form fit functional interface between the ERTMS/ETCS on-board equipment and the vehicle. It is the physical implementation of the interface that is functionally specified in [6]. The references for each function specified in [6] are shown in Table 1-1. The safety requirements for each signal is specified in [13], chapter 2 shall be considered along with this subset.

Section of Subset-119	Name	Section of Subset-034
5.1.1	Sleeping	2.2.1
5.1.2	Passive Shunting	2.2.2
5.1.3	Non Leading	2.2.3
5.1.4	Isolation	2.2.4
5.1.5	Automatic Driving	2.2.5
5.1.6	Remote Shunting	2.2.6
5.2.1	Service Brake Command	2.3.1
5.2.2	Brake Pressure	2.3.2
5.2.3	Emergency Brake Command	2.3.3
5.2.4	Special Brake Inhibition Area – Trackside Orders	2.3.4
5.2.5	Special Brake Inhibit – STM Orders	2.3.5
5.2.5.3	Special Brake Status	2.3.6
5.2.7	Additional Brake Status	2.3.7
5.3.2	Change of Traction System	2.4.1
5.3.3	Powerless Section with Pantograph to be Lowered – Trackside Orders	2.4.2
5.3.4	Pantograph – STM Orders	2.4.3
5.3.5	Air Tightness Area – Trackside Orders	2.4.4
5.3.6	Air Tightness – STM Orders	2.4.5
5.3.7	Station Platform	2.4.6
5.3.8	Powerless Section with Main Power Switch to be Switched Off – Trackside Orders	2.4.7
5.3.9	Main Power Switch – STM Orders	2.4.8
5.3.10	Change of Allowed Current Consumption	2.4.10
5.3.11	Engine Orientation in Supervised Manoeuvre	2.4.11
5.3.12	Traction Cut-Off	2.4.9

Section of Subset-119	Name	Section of Subset-034
5.4.1	Cab Status	2.5.1
5.4.2	Direction Controller	2.5.2
5.4.3	Train Integrity	2.5.3
5.4.4	Traction Status	2.5.4
5.4.5	Set Speed	2.5.5
5.5.1.2	Type of Train Configuration	2.6.4
5.5.2	Type of Train Data Entry	2.6.1
5.5.3	Overall Consist Length Information	2.6.2
5.5.4.2	Train Category	2.6.3
5.5.4.3	Train Length	2.6.3
5.5.4.4	Traction/Brake Parameters	2.6.3
5.5.4.5	Maximum Train Speed	2.6.3
5.5.4.6	Loading Gauge	2.6.3
5.5.4.7	Axle Load Category	2.6.3
5.5.4.8	Traction System(s) Accepted by the Engine	2.6.3
5.5.4.9	Train Fitted with Airtight System	2.6.3
5.6.1	Train Running Number	2.7.1
7	National System Isolation	2.8

Table 1-1 Cross references between Subset-034 and Subset-119

- 1.1.1.2 This interface specification aims at minimising the number of interfaces/components needed for the integration of ERTMS/ETCS on-board equipment into a vehicle.
- 1.1.1.3 In order to cover different applications, any Rolling Stock having an ERTMS/ETCS on-board from basic diesel locomotives to high tech train sets, and from 'newly developed vehicle designs' to 'all other vehicle types and rolling stock in operation', several solutions are specified and all shall be supported by the ERTMS/ETCS on-board.

1.2 Document Structure

- 1.2.1.1 Chapter 1 describes the scope and purpose of the document, the terms and abbreviations and the references
- 1.2.1.2 Chapter 2 describes the architecture of the interface and the naming conventions.
- 1.2.1.3 Chapter 3 describes the general requirements for the hard-wired interface.
- 1.2.1.4 Chapter 4 describes the general requirements for the serial interface as well as the specific requirements for the MVB, the CAN and the ECN.
- 1.2.1.5 Chapter 5 describes the requirements for the signals to be exchanged via the TI.

1.3 References

1.3.1.1 The following references, part of TSI CCS Annex A, are used in this document:

- [1] SUBSET-026 ERTMS/ETCS System Requirements Specification
- [2] ETCS Driver Machine Interface-ERA_ERTMS_015560
- [3] SUBSET-035 Specific Transmission Module (FFFIS)
- [4] SUBSET-091 Safety Requirements for the Technical Interoperability of ETCS in Levels 1 & 2
- [5] TSI LOC&PAS, 1302/2014/EU
- [6] SUBSET-034 FIS for the Train Interface
- [7] SUBSET-023 Glossary of Terms and Abbreviations
- [8] SUBSET-059 Performance Requirements for STMs
- [9] EN50159 Safety related communication in transmission systems
- [10] SUBSET-040 Dimensioning and Engineering rules
- [11] ERA_ERTMS_040001 Assignment of values to ETCS variables
- [12] SUBSET-125 ATO over ETCS – System Requirements Specification
- [13] SUBSET-120 FFFIS TI – Safety Analysis
- [14] SUBSET-147 FFFIS part: CCS Consist Network Communication Layers

1.3.1.2 The following documents, not part of TSI CCS Annex A, are used in this document:

	<u>Version</u>
[15] IEC61375-1 TCN – Train Communication Network – General Architecture	2012

[16]	IEC61375-2-1 TCN – Train Communication Network – WTB	2012
[17]	IEC61375-2-3 TCN – Train Communication Network – Communication Profile	2015
[18]	IEC61375-3-1 TCN – Train Communication Network – MVB	2012
[19]	IEC61375-3-3 TCN – Train Communication Network – CAN	2012
[20]	IEC61375-3-4 TCN – Train Communication Network – ECN	2014
[21]	IEC61158-Serie Profinet	2019
[22]	IEC61784-3-3 Profisafe	2016
[23]	CIP Networks Library from ODVA	2009

1.4 Terms and Abbreviations

1.4.1.1 Only those terms are listed, which are not defined in the ETCS glossary [7]

Option	Option refers to the case in which the hard-wired interface is used instead of the mandatory serial interface.
Hard-wired Interface	An interface where each signal is transmitted by a separate pair of wires.
Serial Interface	An interface where multiple signals are transmitted via a bus/network or a point-to-point connection. Three types of busses are considered in section 4.
Solution	Solution refers to a mandatory implementation.
Traction Cut Off	Inhibit positive traction effort (i.e. driving effort).
Brake actuator	Device that physically brakes the train.
Pressure switch	Device that measures pressure in a brake pipe, main pipe or brake cylinder. It is actuated by a change in pressure at a level threshold.
Train integrator	The one responsible for integration of ERTMS/ETCS on-board in the vehicle
Cycle time on the serial bus	Time between two successive frames or ports which are cyclically transmitted on the serial bus, see [20].

Table 1-2 Terms

1.4.1.2 Only those abbreviations are listed, which are not defined in [7].

ATO-OB	ATO On-Board Unit
BW	Backward
CAN	Controller Area Network
CCS	Control-Command and Signalling
CR	Change Request
cstUUID	unique consist identifier
ECN	Ethernet Consist Network
EC	Eddy Current Brake
ECS	Eddy Current Brake for Service Brake
ECE	Eddy Current Brake for Emergency Brake
EP	Electro Pneumatic Brake
FDT	Fault Detection Time as used in [13]
FW	Forward
MG	Magnetic Shoe Brake
MPU	Main Processor Unit
MVB	Multifunction Vehicle Bus
MSFE	Maximum Safe Front End
mSRE	Minimum Safe Rear End
NID	National Identification
OBU	ERTMS/ETCS On-Board Unit
PG	Pantograph
RIO	Remote Input Output
RB	Regenerative Brake
RST	Rolling Stock
SDT	Safe Data Transmission like defined in [17], Appendix B
SID	Safety Identifier
SSC	Safe Sequence Counter
TCMS	Train Control and Monitoring System



TFR	Tolerable Failure Rate
THR	Tolerable Hazard Rate
TI	Train Interface
TR	Train

Table 1-3 Abbreviations

2. TRAIN INTERFACE

2.1 Architecture

- 2.1.1.1 The Train Interface specified in this document consists of serial interface and hard-wired interface.
- 2.1.1.2 Some signals are only supported over serial interface due to the type of data.
- 2.1.1.3 ERTMS/ETCS on-board equipment shall support the serial interface as defined in this specification and the following four signals on the hard-wired interface: O_EB1_C, O_EB2_C, O_TC1_C, O_IS_S.
- 2.1.1.4 ERTMS/ETCS on-board equipment might also support the signals defined in this specification via the hard-wired interface. In this case, these signals shall be compliant with this specification.
- 2.1.1.5 Serial data defined in this document shall not be distributed over more than one type of BUS in one specific application.
- 2.1.1.6 Figure 2-1 shows the OBU (green colour) interfaced to the vehicle (blue colour) via hard-wired and serial Interface. The interface itself is drawn in red colour.

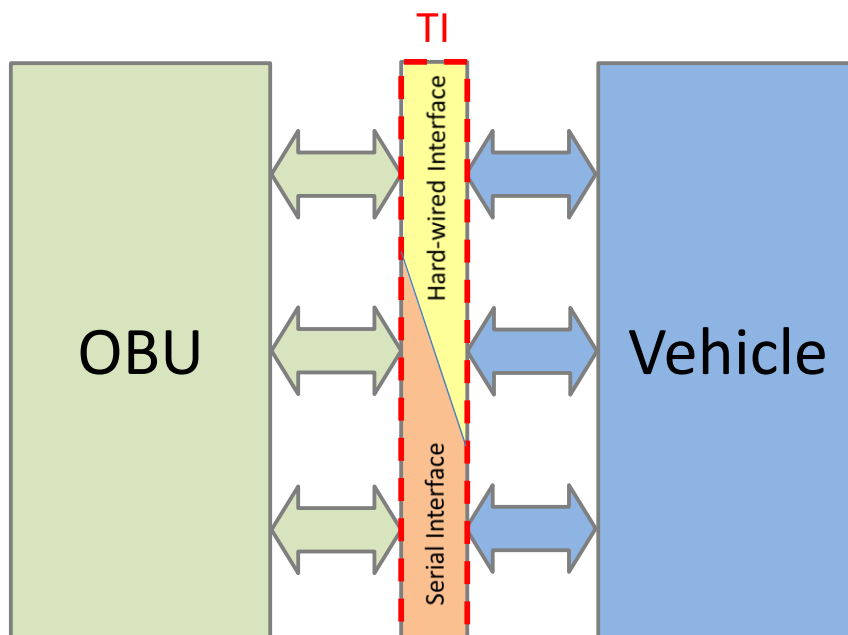

Figure 2-1 Hard-wired and serial links between vehicle and ERTMS/ETCS on-board equipment

- 2.1.1.7 Hard-wired interfaces are defined according to the standardized Reference Input and Output Architecture (RIO) circuits defined in Chapter 3.2.
- 2.1.1.8 The ERTMS/ETCS on-board equipment shall support as serial interface one or several of the following types of bus: CAN, MVB and ECN as defined in chapter 4.
- 2.1.1.9 Table 2-1 gives an overview of the functional I/O with the requirements for which ways of transmission shall be provided mandatorily or optionally. Which information shall be transmitted via the serial or hard-wired interface is marked with “M” for mandatory and which can be transmitted via the hard-wired interface is marked with ‘O’ for optional. On the other hand ‘-’ refers to a case where it is not supported by the interface. Technical requirements for the implementation are described in Chapters 4 and 5.
- 2.1.1.10 Subset-034 [6] contains the mandatory and optional requirements for the application of the I/O functions by the rolling stock subsystem. All I/O functions shall be implemented in the ERTMS/ETCS on-board with the exception of the acquisition of train data information from the train interface which is an optional feature for the ERTMS/ETCS on-board equipment according to [6], 2.6.2.2.
 - 2.1.1.10.1 The simultaneous use of both hard-wired and serial interface for the same functionality is only allowed if required to achieve a safety level as defined in [13], chapter 2 (e.g. EB command, solution 3). Otherwise, either serial or hard-wired interface shall be used for the same function.
 - 2.1.1.10.2 If for a given functionality, optionally the hard-wired interface is used, the corresponding signal on the serial interface shall be provided but shall not be evaluated at the receiving end (either train or ERTMS/ETCS on-board unit according to the source of information).
 - 2.1.1.10.3 Exception 1: EB command as described in solution 3 shall use both hard-wired and serial interface.
 - 2.1.1.10.4 Exception 2: TCO command shall use both hard-wired and serial interface.

No	Functional I/O as per [6]	Source	Hard-wired interface	Serial interface
1	Sleeping	TR	O	M
2	Passive Shunting	TR	O	M
3	Non-Leading	TR	O	M
4	Isolation (of ETCS)	OBU	M	-
5	Automatic Driving	OBU	O	M
6	Remote Shunting	OBU	O	M
7	Service Brake Command	OBU	O	M
8	Brake Pressure	TR	-	M
9	Emergency Brake Command	OBU	M	M
10	Regenerative Brake Inhibit	OBU	-	M ¹
11	Magnetic Shoe Brake Inhibit	OBU	-	M ¹
12	Eddy Current Brakes for Service Brake Inhibit	OBU	-	M ¹
13	Eddy Current Brakes for Emergency Brake Inhibit	OBU	-	M ¹
14	Special Brake Inhibit – STM Orders	OBU	O	M
15	Special Brake Status	TR	O	M
16	Additional Brake Status	TR	O	M
17	Change of Traction System	OBU	-	M ¹
18	Powerless Section with Pantograph to be Lowered – Trackside Orders	OBU	-	M ¹
19	Pantograph – STM Orders	OBU	O	M
20	Air Tightness – Trackside Orders	OBU	-	M ¹
21	Air Tightness – STM Orders	OBU	O	M
22	Station Platform	OBU	-	M ¹
23	Powerless Section with Main Power Switch to be Switched Off – Trackside Orders	OBU	-	M ¹
24	Main Power Switch – STM Orders	OBU	O	M
25	Change of Allowed Current Consumption	OBU	-	M ¹
26	Engine Orientation in Supervised Manoeuvre	OBU	O	M
27	Traction Cut-Off	OBU	M	M
28	Cab Status	TR	O	M
29	Direction Controller	TR	O	M
30	Train Integrity	TR	O	M

31	Traction Status (only for STM)	TR	O	M
32	Set Speed (for DMI indication)	TR	-	M
33	Type of Train Data Entry	TR	O	M
34	Overall Consist Length Information	TR	-	M
35	Train Data Information	TR	O ²	O
36	Train Running Number	TR	-	M
37	National System Isolation	TR	O	M

Table 2-1 Reference to all functional I/O

2.2 Naming Conventions

2.2.1 Signals on the Hard-wired Interface

2.2.1.1 The naming conventions are used to ensure identification of each single signal inside of this specification and the safety requirements in the associated [13], chapter 2.

2.2.1.2 The name of each signal has the following character structure, where each digit indicates the position of a character: 1_23(4)_5_(6)

2.2.1.3 Character 1: Signal source

T = Train

O = ERTMS/ETCS on-board equipment

2.2.1.4 Character 2+3(+4): Function or signal short name

AD	Automatic Driving
AT	Air Tightness
BW	Backward
BP	Brake Position
CS	Cab Status
CT	Change of Traction System
EB1	Emergency Brake 1

¹ For vehicles in which the communication of ERTMS Track Conditions via serial interface is not supported a project specific adaptation is necessary which allows to command the ETCS Track Condition orders via hard-wired interface, see §5.3.1.15.

² Only optional for train fitted with airtight system and brake position. Other signals are available only via serial interface.

EB2	Emergency Brake 2
ECS	Eddy Current Brake for Service Brake
ECE	Eddy Current Brake for Emergency Brake
FAT	Fitted with Airtight System
FW	Forward
IS	Isolation (of ETCS)
MG	Magnetic Shoe Brake
NL	Non Leading
PG	Pantograph
PS	Passive Shunting
RB	Regenerative Brake
RS	Remote Shunting
SB	Service Brake
SL	Sleeping
TC1	Traction Cut-off
TR	Traction Status (only for STM)
TRI	Train Integrity
TT1, TT2	Type of Train Data Entry

2.2.1.5 Character 5: Signal class

A	Status Cab A
B	Status Cab B
C	Command
E	Enable
F	Feedback of a command
I	Inhibition
S	Status

2.2.1.6 Character 6 (optional): Contact index or number of relay (1 to m) or type of logic for the signal (non-inverted or inverted):

1 .. m	Contact index related to the same signal.
N	The non-inverted signal of an antivalent pair.
I	The inverted signal of an antivalent pair.

2.2.1.7 Examples:

O_EB1_C_1 means “Emergency brake 1 command signal contact number 1”.

O_EB1_C_3 means “Emergency brake 1 command signal contact number 3”.

T_SL_E_N means “Sleeping enable not inverted signal”.

2.2.2 Signals on the Serial Interface

2.2.2.1 The naming conventions are used to ensure identification of the signals on the serial interface inside of this specification and the safety requirements in the associated [13], chapter 2.

2.2.2.2 The name of each signal has the following structure, where each digit indicates the position: 1_2_3(_4_5)

2.2.2.3 1: Signal source

TR = Train side

OBU = ERTMS/ETCS on-board equipment

2.2.2.4 2: Signal sink

TR = Train

OBU = ERTMS/ETCS on-board equipment

2.2.2.5 3: signal name in a readable form, giving information about the corresponding function

AirTightFitted	Train Fitted with Airtight System
ACC	Allowed Current Consumption
AD	Automatic Driving
AT	Air Tightness
AxleLoadCat	Axle Load Category
BrakePercentage	Brake percentage
BrakePosition	Brake Position
BrakePressure	Brake Pressure
Brake_Status	Brake Status
CabStatus	Cab Status
CTS	Change of Traction System
DirectionFW	Direction Controller Forward
DirectionBW	Direction Controller Backward
EB3	Emergency Brake 3

ECE / ECEInhibit	Eddy Current Brake for Emergency Brake inhibition
ECS / ECSInhibit	Eddy Current Brake for Service Brake Inhibition
L_CONSISTFRONTCABAMAX	Max Consist Length on the side of the engine corresponding to Cab A and counted from the end of the engine corresponding to the orientation of this cab A
L_CONSISTFRONTCABAMIN	Min Consist Length on the side of the engine corresponding to Cab A and counted from the end of the engine corresponding to the orientation of this cab A
L_CONSISTFRONTCABANOM	Nominal Consist Length on the side of the engine corresponding to Cab A and counted from the end of the engine corresponding to the orientation of this cab A
L_CONSISTREARCABAMAX	Max Consist Length on the side of the engine opposite to Cab A and counted from the end of the engine corresponding to the orientation of this cab A
L_CONSISTREARCABAMIN	Min Consist Length on the side of the engine opposite to Cab A and counted from the end of the engine corresponding to the orientation of this cab A
L_CONSISTREARCABANOM	Nominal Consist Length on the side of the engine opposite to Cab A and counted from the end of the engine corresponding to the orientation of this cab A
LoadingGauge	Loading Gauge
MGI / MGINhibit	Magnetic Shoe Brake Inhibition
MPS	Main Power Switch
NLEnabled	Non Leading
NTCIsolated	National System Isolation
PassiveShunting	Passive Shunting
PG	Pantograph
RBI / RBInhibit	Regenerative Brake Inhibition
RS	Remote Shunting
ServiceBrake	Service Brake
SetSpeed	Set Speed (for DMI indication)
SP	Station Platform
SupTractionSys	Supported Traction Systems
TCO	Traction Cut-Off
Traction_Status	Traction Status (only for STM)

TrainCatCantDef	Train Category Cant Deficiency
TypeTrainConfiguration	Type of Train Configuration
TrainIntegrity	Train Integrity
TrainLength	Train Length
TrainSleep	Sleeping
TypeTrainData	Type of Train Data Entry

2.2.2.6 4_5: if necessary, more detailed information about the signal/function (Status, Feedback, information about possible iterations, additional names, explanation if signal is inverted)

3. GENERAL REQUIREMENTS FOR THE HARD-WIRED INTERFACE

3.1 General Requirements

3.1.1.1 For the ERTMS/ETCS on-board the hard-wired interface for the signals specified in clause 2.1.1.3 is mandatory. It shall comply with the requirements in this section 3.

3.1.1.2 The cabling between the vehicle and the ERTMS/ETCS on-board is within the responsibility of the vehicle.

3.2 Reference Input and Output Architecture (RIO)

3.2.1.1 Output refers to the information from the OBU to the vehicle.

3.2.1.2 Input refers to the information from the vehicle to the OBU.

3.2.1.3 For binary inputs and outputs the following architecture is defined:

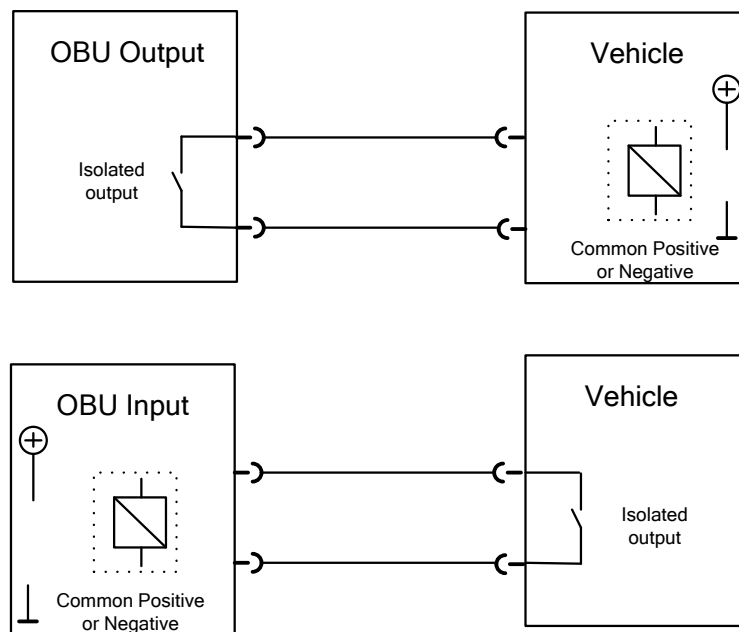

Figure 3-1 Reference I/O pair

3.2.1.3.1 Note1: Figure represents the functionality of an isolated output, but it is not restricted to a specific design.

3.2.1.3.2 Characteristics for input signals are specified by the ERTMS/ETCS on-board power supply, whereas the characteristics for the output signals are specified by the vehicle power supply.

3.2.1.3.3 Characteristics for input and output signals are listed in the Table 3-2 and Table 3-3.

3.2.1.4 Definition of signal states:

Signal	Output	Level
0	Open (high impedance)	Low
1	Closed (low impedance)	High

Table 3-1 Definition of signal states

3.3 Boolean OBU Inputs

3.3.1.1 For input signals, the input information shall be considered as stable whenever the values of the signal remains unchanged for a period greater than the time $t_{transient_period_inputs}$ which is configurable. During the transient time, the state of the input information has to be considered as unchanged.

3.3.1.2 Inputs shall have the following characteristics:

Characteristic	Value
Max. voltage between pins	<ul style="list-style-type: none"> • 24 V + overvoltage according EN 50155 • 48 V + overvoltage according EN 50155 • 72 V + overvoltage according EN 50155 • 96 V + overvoltage according EN 50155 • 110 V + overvoltage according EN 50155
Max. input current in High level* ¹	<ul style="list-style-type: none"> • 200 mA for 24 V nominal voltage • 100 mA for 48 V nominal voltage • 60 mA for 72 V nominal voltage • 50 mA for 96 V and 110 V nominal voltage
Max. L/R* ²	<ul style="list-style-type: none"> • 40ms
Min. input current in High level* ¹	<ul style="list-style-type: none"> • 4 mA for 24 V nominal voltage • 4 mA for 48V nominal voltage • 3 mA for 72V nominal voltage • 2 mA for 96V nominal voltage • 2 mA for 110V nominal voltage • Otherwise: 1 mA and transient peak
Max. input current that has to be detected as Low level* ^{3*1}	<ul style="list-style-type: none"> • 250µA

Table 3-2 Characteristics for OBU Boolean Inputs

3.3.1.2.1 *1: Input current is the current that flows through the input pin.

3.3.1.2.2 *2: L/R is the fraction of inductance over the resistance of the load.

3.3.1.2.3 *3: Higher currents could also be detected as Low level, but should be avoided by the vehicle output.

3.4 Boolean OBU Outputs

3.4.1.1 In case of two (or more) independent output signals composing a single output, the output information shall be considered as stable whenever the values of the two (or more) signals remain unchanged for a period greater than the time $t_{\text{transient_period_outputs}}$ which is configurable.

3.4.1.2 Outputs shall comply with the following characteristics:

Characteristic	Value
Max. voltage between output pins in "Open" state	<ul style="list-style-type: none"> • 24 V + over-voltage according EN 50155 • 48 V + over-voltage according EN 50155 • 72 V + over-voltage according EN 50155 • 96 V + over-voltage according EN 50155 • 110 V + over-voltage according EN 50155
Max. continuous current through output in "Closed" state	<ul style="list-style-type: none"> • 1 A for 24 V nominal voltage • 0.5 A for 48 V nominal voltage • 0.3 A for 72 V nominal voltage • 0.2 A for 96 V and 110 V nominal voltage
Lowest possible output current in Closed status	High Power Outputs
	<ul style="list-style-type: none"> • 15 mA for 24 V nominal voltage • 15 mA for 48 V nominal voltage • 13 mA for 72 V nominal voltage • 10 mA for 96 V nominal voltage • 10 mA for 110 V nominal voltage
	Low Power Outputs
	<ul style="list-style-type: none"> • 4 mA for 24 V nominal voltage • 4 mA for 48 V nominal voltage • 3 mA for 72 V nominal voltage • 2 mA for 96 V nominal voltage • 2 mA for 110 V nominal voltage
Max. leakage current in Open status at any voltage	250 μ A
Max. L/R* ¹	40 ms
Max. allowed time for a signal with two independent outputs to be invalid in transition phase	100 ms (this time covers switching time between independent outputs and contact bouncing time)
Output durability (in operating cycles)	\geq 100.000 electrically at 20 VA load and 40 ms L/R

Table 3-3 Characteristics for OBU Boolean outputs

3.4.1.2.1 *1 L/R is the fraction of inductance over the resistance of the load.

4. GENERAL REQUIREMENTS FOR THE SERIAL INTERFACE

4.1 General Requirements

- 4.1.1.1 For the ERTMS/ETCS on-board the serial interface is mandatory. It shall comply with the requirements in this section and specified in [14].
- 4.1.1.2 This chapter includes the solutions regarding the ECN, MVB and CAN based on [17], [18], [19], [20], [21], [22], and [23].
- 4.1.1.2.1 Note: The application communication protocols, e.g. PROFINET, CIP, and TRDP are supplementary protocols for the application of ECN.
- 4.1.1.3 All data is transmitted cyclically as process data (see [15] for process data definition).
- 4.1.1.4 Transmission cycle time for the process data on the serial bus shall be the one defined in Table 4-1.

4.2 Serial Architectures

4.2.1 General

- 4.2.1.1 There are two possible architectures for the transmission of information via a serial bus – architecture a) and b). Both architectures are fit for the transmission of safety related and non-safety related information as defined [13], chapter 2. It is up to the train integrator to choose the adequate architecture.

4.2.2 Architecture a)

- 4.2.2.1 Note: This architecture allows the use of hardware which is not able to implement requirements defined in [9] necessary for safety related communication.
- 4.2.2.2 Note: The interface on the serial bus regarding port and packet structure depends on the used I/O module hardware. As the frames on the serial bus of an I/O module hardware depends of its design and is not standardised the interface cannot be standardised. In case of architecture a) the realisation could deviate from the packets defined in chapter 4.3.

4.2.2.3 The following figure describes architecture a).

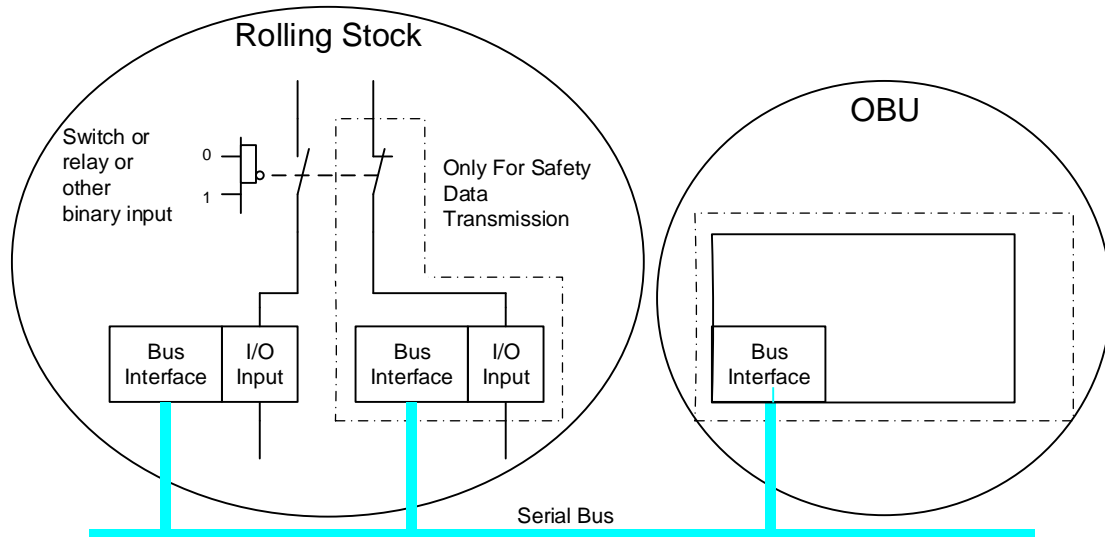

Figure 4-1 Architecture a)

4.2.2.4 The architecture can define information signals using either single contact or antivalent contacts.

4.2.2.5 When using Architecture a), the following principles shall be used for safety related information:

4.2.2.5.1 Information shall be derived using antivalent contacts.

4.2.2.5.2 In case of antivalent/redundant input/output information is required separate I/O hardware shall be used.

4.2.3 Architecture b)

- 4.2.3.1 Note: This architecture allows the use of hardware which is able to implement requirements defined in [9] necessary for safety related communication.
- 4.2.3.2 The architecture allows the transmission of both non-safety related and safety related information.
- 4.2.3.3 Using safety devices the TFR achievable depends on the Rolling Stock (e.g. TCMS) design (Hardware and software).

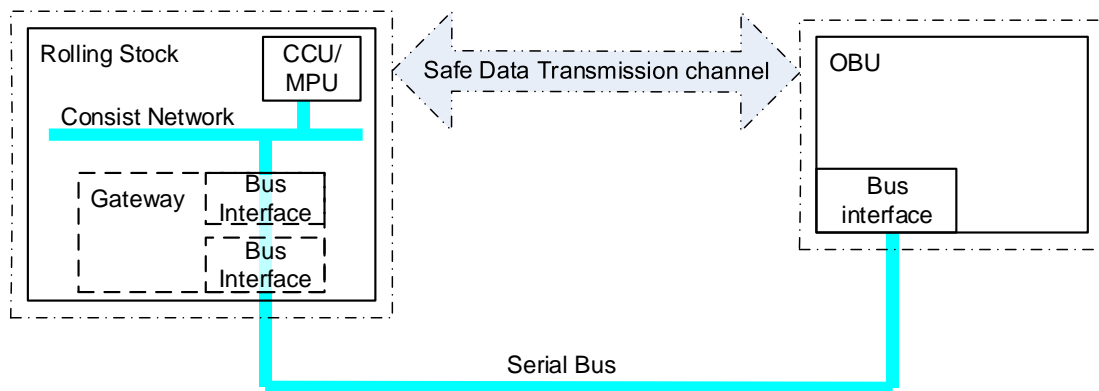

Figure 4-2 Architecture b)

- 4.2.3.4 When using Architecture b) safe data transmission shall be applied according to [17], Appendix B when the required safety integrity level of certain functionality cannot be fulfilled with safety integrity level provided by the serial bus transmission.
- 4.2.3.5 Exception: In case the safety protocol ProfiSafe according to IEC 61784-3-3 [22] is applied, the SDT trailer is replaced by the ProfiSafe trailer.
- 4.2.3.6 Optionally the Rolling Stock (e.g. TCMS) can integrate a gateway to adapt to the bus type defined by the ERTMS/ETCS on-board. The additional transfer delay introduced due the implementation of the gateway shall be below 200ms (worst case).

4.3 Coding

4.3.1 General

- 4.3.1.1 This chapter presents the definition of the data to be transmitted via Bus.
- 4.3.1.2 The structure of the packets defined below is identical for both safety and non-safety related information.
- 4.3.1.3 The packets on the serial bus shall provide for each signal a specific validity bit to be set at source side.
 - 4.3.1.3.1 A signal has its validity bit set to false if it is not used on the source side i.e. the signal is spare (the part of a packet is not used) or the signal is not trustable due to a problem on the source side.
 - 4.3.1.3.2 Note: The validity bit is set to TRUE independently on whether the signal is used by the receiver or not.
- 4.3.1.4 Signals not provided from the defined source shall be marked as not used by setting the related validity bit to FALSE at source side.
 - 4.3.1.4.1 In case EB command is performed as described in Solution 1 (see §5.2.3.2.7) or Solution 2 (see §5.2.3.2.8), the signal OBU_TR_EB3_Cmd shall not be used.
- 4.3.1.5 The Serial Interface Table 4-1, provided in section 4.3.2, describes for each function the maximum cycle time, signal size in bit, data type for transmission, name on hard-wired interface, name on serial interface and a comment.
- 4.3.1.6 The tables in chapter 4.3.3 to 4.3.13 describing the coding of the different packets sent from OBU and TR are derived from Table 4-1. The packets for MVB, CAN and ECN differ



only in the additional trailer necessary for safe data transmission (in case of architecture b), see 4.2.3).

- 4.3.1.7 The packets are defined in big endian byte order. The data ordering in packets shall be according to [16].
- 4.3.1.8 Spare bits and bytes in the packets shall be set to 0.
- 4.3.1.9 If the validity bit is set to 0 a spare value check of this data field shall not take place.

4.3.2 Serial Interface Signals

4.3.2.1 Note: The signal types used in the following table are defined in [16], table 19.

Function	maximum cycle time for MVB and CAN / ECN [ms]	signal size[Bit]	signal type for transmission	name on serial interface	Comment
Sleeping	128 / 100	2	2*BOOLEAN1	TR_OBU_TrainSleep, TR_OBU_TrainSleep_Not	Enable sleeping function <u>Coding:</u> see Table 5-1
Passive Shunting	128 / 100	1	BOOLEAN1	TR_OBU_PassiveShunting	Passive shunting <u>Coding:</u> see Table 5-2
Service Brake	128 / 100	1	BOOLEAN1	OBU_TR_ServiceBrake	Service brake command <u>Coding:</u> see Table 5-7
Emergency Brake	128 / 100	1	BOOLEAN1	OBU_TR_EB3_Cmd	EB 3 command <u>Coding:</u> see Table 5-9. Note: the EB command via the serial interface refers to Figure 5-6
Traction Cut Off	128 / 100	1	BOOLEAN1	OBU_TR_TCO_Cmd	Traction cut-off <u>Coding:</u> see Table 5-35
Non Leading	128 / 100	1	BOOLEAN1	TR_OBU_NLEnabled	Non Leading <u>Coding:</u> see Table 5-3

Function	maximum cycle time for MVB and CAN / ECN [ms]	signal size[Bit]	signal type for transmission	name on serial interface	Comment
Automatic Driving	128 / 100	1	BOOLEAN1	OBU_TR_AD_StatusStatus	Status for Automatic Driving <u>Coding:</u> see Table 5-5
Remote Shunting	128 / 100	1	2*BOOLEAN1	OBU_TR_RS_Status	Status for Remote Shunting <u>Coding:</u> see Table 5-6
Direction Controller	128 / 100	2	2*BOOLEAN1	TR_OBU_DirectionFW, TR_OBU_DirectionBW	Status of Direction controller relative to occupied cab <u>Coding:</u> see Table 5-37
Cab Status	128 / 100	2	2*BOOLEAN1	TR_OBU_CabStatusA, TR_OBU_CabStatusB	Status of Cabs <u>Coding:</u> see Table 5-36
Brake Pressure	128 / 100	8	UNSIGNED8	TR_OBU_BrakePressure	Brake Pressure <u>Coding:</u> see Table 5-8
Special Brake Inhibition Area – Trackside Orders (Regenerative Brake Inhibit)	256 / 200	16	INTEGER16, 2's complement	OBU_TR_RBI_D_Entry	Remaining distance from the max safe front end to the start location of the regenerative brake inhibition area <u>Coding:</u> see Table 5-23
Special Brake Inhibition Area – Trackside Orders (Regenerative Brake Inhibit)	256 / 200	16	INTEGER16, 2's complement	OBU_TR_RBI_D_Exit	Remaining distance from the min safe rear end to the end location of the regenerative brake inhibition area <u>Coding:</u> see Table 5-24

Function	maximum cycle time for MVB and CAN / ECN [ms]	signal size[Bit]	signal type for transmission	name on serial interface	Comment
Special Brake Inhibit – STM Orders	128 / 100	1	BOOLEAN1	OBU_TR_RBInhibit_Cmd	Regenerative brake inhibit command Coding: see Table 5-15
Special Brake Inhibition Area – Trackside Orders (Magnetic Shoe Brake Inhibit)	256 / 200	16	INTEGER16, 2's complement	OBU_TR_MGI_D_Entry	Remaining distance from the max safe front end to the start location of the magnetic shoe brake inhibition area Coding: see Table 5-23
Special Brake Inhibition Area – Trackside Orders (Magnetic Shoe Brake Inhibit)	256 / 200	16	INTEGER16, 2's complement	OBU_TR_MGI_D_Exit	Remaining distance from the min safe rear end to the end location of the magnetic shoe brake inhibition area Coding: see Table 5-24
Special Brake Inhibit – STM Orders	128 / 100	1	BOOLEAN1	OBU_TR_MGIInhibit_Cmd	Magnetic shoe brake inhibit command Coding: see Table 5-16
Special Brake Inhibition Area – Trackside Orders (Eddy Current Brakes for Service Brake Inhibit)	256 / 200	16	INTEGER16, 2's complement	OBU_TR_ECS_D_Entry	Remaining distance from the max safe front end to the start location of the inhibition area of the eddy current brake for service brake Coding: see Table 5-23

Function	maximum cycle time for MVB and CAN / ECN [ms]	signal size[Bit]	signal type for transmission	name on serial interface	Comment
Special Brake Inhibition Area – Trackside Orders (Eddy Current Brakes for Service Brake Inhibit)	256 / 200	16	INTEGER16, 2's complement	OBU_TR_ECS_D_Exit	Remaining distance from the min safe rear end to the end location of the inhibition area of the eddy current brake for service brake <u>Coding:</u> see Table 5-24
Special Brake Inhibit – STM Orders	128 / 100	1	BOOLEAN1	OBU_TR_ECSInhibit_Cmd	Eddy current brake inhibit command for service brake <u>Coding:</u> see Table 5-17
Special Brake Inhibition Area – Trackside Orders (Eddy Current Brakes for Emergency Brake Inhibit)	256 / 200	16	INTEGER16, 2's complement	OBU_TR_ECE_D_Entry	Remaining distance from the max safe front end to the start location of the inhibition area of the eddy current brake for emergency brake <u>Coding:</u> see Table 5-23
Special Brake Inhibition Area – Trackside Orders (Eddy Current Brakes for Emergency Brake Inhibit)	256 / 200	16	INTEGER16, 2's complement	OBU_TR_ECE_D_Exit	Remaining distance from the min safe rear end to the end location of the inhibition area of the eddy current brake for emergency brake <u>Coding:</u> see Table 5-24

Function	maximum cycle time for MVB and CAN / ECN [ms]	signal size[Bit]	signal type for transmission	name on serial interface	Comment
Special Brake Inhibit – STM Orders	128 / 100	1	BOOLEAN1	OBU_TR_ECEInhibit_Cmd	Eddy current brakes inhibit command for emergency brake <u>Coding:</u> see Table 5-18
Brake Status	128 / 100	8	BITSET8	TR_OBU_Brake_Status	Brake status <u>Coding for each bit:</u> Bit0: Electro Pneumatic Brake Status (EP_S), see Table 5-19 Bit1: Electro Pneumatic Brake Status (EP_S_Not), see Table 5-19 Bit2: Eddy Current Brake Status (EC_S), see Table 5-20 Bit3: Eddy Current Brake Status (EC_S_Not), see Table 5-20 Bit4: Regenerative Brake Status (RB_S), see Table 5-21 Bit5: Regenerative Brake Status (RB_S_Not), see Table 5-21 Bit6: Magnetic Shoe Brake Status (MG_S), see Table 5-22 Bit7: Magnetic Shoe Brake Status (MG_S_Not), see Table 5-22
Type of Train Data Entry	256 / 200	2	2*BOOLEAN1	TR_OBU_TypeTrainData_S1, TR_OBU_TypeTrainData_S2	Type of train data entry. <u>Coding:</u> see Table 5-43
Type of Train Configuration	256 / 200	8	UNSIGNED8	TR_OBU_TypeTrainConfiguration	Type of Train Configuration. <u>Coding:</u> bit 0..4 see Table 5-42 bit 5..7 set to 0
Train Data	256 / 200	12	UNSIGNED16	TR_OBU_L_ CONSISTFRONTCABAMAX	Max consist length on the side of the Engine corresponding to Cab A <u>Coding:</u> bit 0..11 see Table 5-44 bit 12..15 set to 0
Train Data	256 / 200	12	UNSIGNED16	TR_OBU_L_ CONSISTFRONTCABAMIN	Min consist length on the side of the Engine corresponding to Cab A <u>Coding:</u> bit 0..11 see Table 5-44 bit 12..15 set to 0



Function	maximum cycle time for MVB and CAN / ECN [ms]	signal size[Bit]	signal type for transmission	name on serial interface	Comment
Train Data	256 / 200	12	UNSIGNED16	TR_OBU_L_ CONSISTFRONTCABANOM	Nominal consist length on the side of the Engine corresponding to Cab A <u>Coding:</u> bit 0..11 see Table 5-44 bit 12..15 set to 0
Train Data	256 / 200	12	UNSIGNED16	TR_OBU_L_ CONSISTREARCABAMAX	Max consist length on the side of the Engine opposite to Cab A <u>Coding:</u> bit 0..11 see Table 5-44 bit 12..15 set to 0
Train Data	256 / 200	12	UNSIGNED16	TR_OBU_L_ CONSISTREARCABAMIN	Min consist length on the side of the Engine opposite to Cab A <u>Coding:</u> bit 0..11 see Table 5-44 bit 12..15 set to 0
Train Data	256 / 200	12	UNSIGNED16	TR_OBU_L_ CONSISTREARCABANOM	Nominal consist length on the side of the Engine opposite to Cab A <u>Coding:</u> bit 0..11 see Table 5-44 bit 12..15 set to 0
Train Data	256 / 200	4	UNSIGNED8	TR_OBU_TrainCatCantDef	Train data: train category cant deficiency <u>Coding:</u> bit 0..3 see 5.5.4.2.3.1 bit 4..7 set to 0
Train Data	256 / 200	12	UNSIGNED16	TR_OBU_TrainLength	Train data: train length <u>Coding:</u> bit 0..11 see 5.5.4.3.3.1 bit 12..15 set to 0
Train Data	256 / 200	8	UNSIGNED8	TR_OBU_BrakePercentage	Train data: brake percentage <u>Coding:</u> bit 0..8 see 5.5.4.4.4.3
Train Data	256 / 200	4	4*BOOLEAN1	TR_OBU_BrakePosition1, TR_OBU_BrakePosition1_Not, TR_OBU_BrakePosition2, TR_OBU_BrakePosition2_Not	Train data: Brake Position <u>Coding:</u> see Table 5-46

© This document has been developed and released by UNISIG in collaboration with Faiveley Transport, Knorr-Bremse, TÜV, Voith Turbo and Vossloh

Function	maximum cycle time for MVB and CAN / ECN [ms]	signal size[Bit]	signal type for transmission	name on serial interface	Comment
Train Data	256 / 200	8	UNSIGNED8	TR_OBU>LoadingGauge	Train data: loading gauge <u>Coding:</u> see 5.5.4.6.3.1
Train Data	256 / 200	7	UNSIGNED8	TR_OBU>AxleLoadCat	Train data: axle load category <u>Coding:</u> bit 0..6 see 5.5.4.7.3.1 bit 7 set to 0
Train Data	256 / 200	10	UNSIGNED32	TR_OBU>SupTractionSys	Train data: list of supported available traction systems i <u>Coding:</u> bit 0 set o 0 bit 1..31 see 5.5.4.8.3
Train Data	256 / 200	1	BOOLEAN1	TR_OBU>AirTightFitted	Train data: train fitted with airtight system <u>Coding:</u> see Table 5-48

Function	maximum cycle time for MVB and CAN / ECN [ms]	signal size[Bit]	signal type for transmission	name on serial interface	Comment
National System Isolation	128 / 100	16	UNSIGNED16	TR_OBU_NTCIsolated	National System Isolation <u>Coding:</u> Coding for each bit (see Table 5-50): Bit0: NTC system 1 (T_IS_S_N1 / ISS1) Bit1: NTC system 2 (T_IS_S_N2 / ISS2) Bit2: NTC system 3 (T_IS_S_N3 / ISS3) Bit3: NTC system 4 (T_IS_S_N4 / ISS4) Bit4: NTC system 5 (T_IS_S_N5 / ISS5) Bit5: NTC system 6 (T_IS_S_N6 / ISS6) Bit6: NTC system 7 (T_IS_S_N7 / ISS7) Bit7: NTC system 8 (T_IS_S_N8 / ISS8) Bit8: NTC system 9 (T_IS_S_N9 / ISS9) Bit9: NTC system 10 (T_IS_S_N10 / ISS10) Bit10: NTC system 11 (T_IS_S_N11 / ISS11) Bit11: NTC system 12 (T_IS_S_N12 / ISS12) Bit12: NTC system 13 (T_IS_S_N13 / ISS13) Bit13: NTC system 14 (T_IS_S_N14 / ISS14) Bit14: NTC system 15 (T_IS_S_N15 / ISS15) Bit15: NTC system 16 (T_IS_S_N16 / ISS16)

Function	maximum cycle time for MVB and CAN / ECN [ms]	signal size[Bit]	signal type for transmission	name on serial interface	Comment
National System Isolation	128 / 100	16	UNSIGNED16	TR_OBU_NTCIsolated_Not	<p>National System Isolation Inverted (in case the NTCx safety level requires a second signal)</p> <p><u>Coding:</u></p> <p><u>Coding for each bit (see Table 5-50):</u> Bit0: NTC system 1 (T_IS_S_I1 / ISS_Not1) Bit1: NTC system 2 (T_IS_S_I2 / ISS_Not2) Bit2: NTC system 3 (T_IS_S_I3 / ISS_Not3) Bit3: NTC system 4 (T_IS_S_I4 / ISS_Not4) Bit4: NTC system 5 (T_IS_S_I5 / ISS_Not5) Bit5: NTC system 6 (T_IS_S_I6 / ISS_Not6) Bit6: NTC system 7 (T_IS_S_I7 / ISS_Not7) Bit7: NTC system 8 (T_IS_S_I8 / ISS_Not8) Bit8: NTC system 9 (T_IS_S_I9 / ISS_Not9) Bit9: NTC system 10 (T_IS_S_I10 / ISS_Not10) Bit10: NTC system 11 (T_IS_S_I11 / ISS_Not11) Bit11: NTC system 12 (T_IS_S_I12 / ISS_Not12) Bit12: NTC system 13 (T_IS_S_I13 / ISS_Not13) Bit13: NTC system 14 (T_IS_S_I14 / ISS_Not14) Bit14: NTC system 15 (T_IS_S_I15 / ISS_Not15) Bit15: NTC system 16 (T_IS_S_I16 / ISS_Not16)</p>
Change of Traction System	128 / 100	16	INTEGER16, 2's complement	OBU_TR_CTS_D_Change	<p>Remaining distance from the max safe front end to the location of change of traction system</p> <p><u>Coding:</u> see Table 5-23</p>
Change of Traction System	128 / 100	10	UNSIGNED16	OBU_TR_CTS_NewId	<p>Country identifier of the new traction system</p> <p><u>Coding:</u> bits 0..9: see Table 5-25 bits 10..15: spare bits</p>

Function	maximum cycle time for MVB and CAN / ECN [ms]	signal size[Bit]	signal type for transmission	name on serial interface	Comment
Change of Traction System	128 / 100	4	UNSIGNED8	OBU_TR_CTS_NewVoltage	Voltage of the new traction system <u>Coding:</u> bits 0..3: see Table 5-25 bits 4..7: spare bits
Powerless Section with Pantograph to be Lowered – Trackside Orders	256 / 200	16	INTEGER16, 2's complement	OBU_TR_PG_D_Entry	Remaining distance from the max safe front end to the start location of the powerless section with pantograph to be lowered <u>Coding:</u> see Table 5-23
Powerless Section with Pantograph to be Lowered – Trackside Orders	256 / 200	16	INTEGER16, 2's complement	OBU_TR_PG_D_Exit	Remaining distance from the min safe front end to the end location of the powerless section with pantograph to be lowered <u>Coding:</u> see Table 5-24
Pantograph – STM Orders	128 / 100	1	BOOLEAN1	OBU_TR_PG_Cmd	Pantograph command <u>Coding:</u> see Table 5-27
Air Tightness Area – Trackside Orders	256 / 200	16	INTEGER16, 2's complement	OBU_TR_AT_D_Entry	Remaining distance from the max safe front end to the start location of the air tightness area <u>Coding:</u> see Table 5-23
Air Tightness Area – Trackside Orders	256 / 200	16	INTEGER16, 2's complement	OBU_TR_AT_D_Exit	Remaining distance from the min safe rear end to the end location of the air tightness area <u>Coding:</u> see Table 5-24

Function	maximum cycle time for MVB and CAN / ECN [ms]	signal size[Bit]	signal type for transmission	name on serial interface	Comment
Air Tightness – STM Orders	128 / 100	1	BOOLEAN1	OBU_TR_AT_Cmd	Command air tightness command <u>Coding:</u> see Table 5-29
Station Platform	256 / 200	16	INTEGER16, 2's complement	OBU_TR_SP_D_Entry1	Remaining distance from the max safe front end to the start location of the platform 1 <u>Coding:</u> see Table 5-23
Station Platform	256 / 200	16	INTEGER16, 2's complement	OBU_TR_SP_D_Exit1	Remaining distance from the min safe front end to the end location of the platform 1 <u>Coding:</u> see Table 5-24
Station Platform	256 / 200	4	4*BOOLEAN1	OBU_TR_SP_Height1_Bit0, OBU_TR_SP_Height1_Bit1, OBU_TR_SP_Height1_Bit2, OBU_TR_SP_Height1_Bit3	Height of the platform 1 <u>Coding:</u> see Table 5-30
Station Platform	256 / 200	2	2*BOOLEAN1	OBU_TR_SP_Right1, OBU_TR_SP_Left1	Side the platform 1 is on. <u>Coding (OBU_TR_SP_Left, OBU_TR_SP_Right):</u> see Table 5-30
Station Platform	256 / 200	16	INTEGER16, 2's complement	OBU_TR_SP_D_Entry2	Remaining distance from the max safe front end to the start location of the platform 2 <u>Coding:</u> see Table 5-23
Station Platform	256 / 200	16	INTEGER16, 2's complement	OBU_TR_SP_D_Exit2	Remaining distance from the min safe front end to the end location of the platform 2 <u>Coding:</u> see Table 5-24
Station Platform	256 / 200	4	4*BOOLEAN1	OBU_TR_SP_Height2_Bit0, OBU_TR_SP_Height2_Bit1, OBU_TR_SP_Height2_Bit2, OBU_TR_SP_Height2_Bit3	Height of the platform 2 <u>Coding:</u> see Table 5-30

Function	maximum cycle time for MVB and CAN / ECN [ms]	signal size[Bit]	signal type for transmission	name on serial interface	Comment
Station Platform	256 / 200	2	2*BOOLEAN1	OBU_TR_SP_Right2, OBU_TR_SP_Left2	Side the platform 2 is on. <u>Coding</u> (OBU_TR_SP_Left, OBU_TR_SP_Right); see Table 5-30
Station Platform	256 / 200	16	INTEGER16, 2's complement	OBU_TR_SP_D_Entry3	Remaining distance from the max safe front end to the start location of the platform 3 <u>Coding</u> ; see Table 5-23
Station Platform	256 / 200	16	INTEGER16, 2's complement	OBU_TR_SP_D_Exit3	Remaining distance from the min safe front end to the end location of the platform 3 <u>Coding</u> ; see Table 5-24
Station Platform	256 / 200	4	4*BOOLEAN1	OBU_TR_SP_Height3_Bit0, OBU_TR_SP_Height3_Bit1, OBU_TR_SP_Height3_Bit2, OBU_TR_SP_Height3_Bit3	Height of the platform 3 <u>Coding</u> ; see Table 5-30
Station Platform	256 / 200	2	2*BOOLEAN1	OBU_TR_SP_Right3, OBU_TR_SP_Left3	Side the platform 3 is on. <u>Coding</u> (OBU_TR_SP_Left, OBU_TR_SP_Right); see Table 5-30
Station Platform	256 / 200	16	INTEGER16, 2's complement	OBU_TR_SP_D_Entry4	Remaining distance from the max safe front end to the start location of the platform 4 <u>Coding</u> ; see Table 5-23
Station Platform	256 / 200	16	INTEGER16, 2's complement	OBU_TR_SP_D_Exit4	Remaining distance from the min safe front end to the end location of the platform 4 <u>Coding</u> ; see Table 5-24
Station Platform	256 / 200	4	4*BOOLEAN1	OBU_TR_SP_Height4_Bit0 , OBU_TR_SP_Height4_Bit1, OBU_TR_SP_Height4_Bit2, OBU_TR_SP_Height4_Bit3	Height of the platform 4 <u>Coding</u> ; see Table 5-30



Function	maximum cycle time for MVB and CAN / ECN [ms]	signal size[Bit]	signal type for transmission	name on serial interface	Comment
Station Platform	256 / 200	2	2*BOOLEAN1	OBU_TR_SP_Right4, OBU_TR_SP_Left4	Side the platform 4 is on. Coding (OBU_TR_SP_Left, OBU_TR_SP_Right); see Table 5-30
Station Platform	256 / 200	16	INTEGER16, 2's complement	OBU_TR_SP_D_Entry5	Remaining distance from the max safe front end to the start location of the platform 5 Coding: see Table 5-23
Station Platform	256 / 200	16	INTEGER16, 2's complement	OBU_TR_SP_D_Exit5	Remaining distance from the min safe front end to the end location of the platform 5 Coding: see Table 5-24
Station Platform	256 / 200	4	4*BOOLEAN1	OBU_TR_SP_Height5_Bit0, OBU_TR_SP_Height5_Bit1, OBU_TR_SP_Height5_Bit2, OBU_TR_SP_Height5_Bit3	Height of the platform 5 Coding: see Table 5-30
Station Platform	256 / 200	2	2*BOOLEAN1	OBU_TR_SP_Right5, OBU_TR_SP_Left5	Side the platform 5 is on. Coding (OBU_TR_SP_Left, OBU_TR_SP_Right); see Table 5-30
Powerless Section with Main Power Switch to be Switched Off – Trackside Orders	256 / 200	16	INTEGER16, 2's complement	OBU_TR_MPS_D_Entry	Remaining distance from the max safe front end to the start location of the powerless section with main power switch to be switched off Coding: see Table 5-23
Powerless Section with Main Power Switch to be Switched Off – Trackside Orders	256 / 200	16	INTEGER16, 2's complement	OBU_TR_MPS_D_Exit	Remaining distance from the min safe front end to the end location of the powerless section with main power switch to be switched off Coding: see Table 5-24

© This document has been developed and released by UNISIG in collaboration with Faiveley Transport, Knorr-Bremse, TÜV, Voith Turbo and Vossloh

Function	maximum cycle time for MVB and CAN / ECN [ms]	signal size[Bit]	signal type for transmission	name on serial interface	Comment
Main Power Switch – STM Orders	128 / 100	1	BOOLEAN1	OBU_TR_MPS_Cmd	MPS open command <u>Coding:</u> see Table 5-32
Change of Allowed Current Consumption	128 / 100	16	INTEGER16, 2's complement	OBU_TR_ACC_D_Change	Remaining distance from the max safe front end to the location of change of allowed current consumption <u>Coding:</u> see Table 5-23
Change of Allowed Current Consumption	128 / 100	10	UNSIGNED16	OBU_TR_ACC_Limit	New allowed current consumption <u>Coding:</u> Bit 0..9: see Table 5-33 Bit 10..15: spare
Engine Orientation in Supervised Manoeuvre	128 / 100	1	BOOLEAN1	OBU_TR_EngOrientSM	Engine Orientation in Supervised Manoeuvre <u>Coding:</u> see Table 5-34
Traction Status (only for STM)	128 / 100	1	BOOLEAN1	TR_OBU_Traction_Status	Traction status <u>Coding:</u> see Table 5-39
Set Speed value	128 / 100	16	UNSIGNED16	TR_OBU_SetSpeedValue	Set speed value <u>Coding:</u> see Table 5-40
Set Speed display	128 / 100	1	BOOLEAN1	TR_OBU_SetSpeedDisplay	Set speed display <u>Coding:</u> see Table 5-41

Function	maximum cycle time for MVB and CAN / ECN [ms]	signal size[Bit]	signal type for transmission	name on serial interface	Comment
Train Integrity	256 / 200	4	4*BOOLEAN1	TR_OBU_TrainIntegrity_S1, TR_OBU_TrainIntegrity_S1_Not, TR_OBU_TrainIntegrity_S2, TR_OBU_TrainIntegrity_S2_Not	Train integrity <u>Coding:</u> see Table 5-38
Train Running Number	256 / 200	32	UNSIGNED32	TR_OBU_NID_OPERATIONAL	Train running number <u>Coding:</u> see Table 5-49

Table 4-1 Generic Serial Interface Table

- 4.3.2.2 All signals are transmitted over the networks in packets according to reference [15]. The list of the various packets is given hereafter in the following paragraphs.
- 4.3.2.3 The safety protocol ProfiSafe according to IEC 61784-3-3 [22] requires the use of a limited range of data types and a specific order of signals in a packet depending on their data types. In order to fulfil IEC 61784-3-3 [23], the data structures (codings and packets) defined in the following chapters need to be re-arranged. The data structures applicable in this case are defined in Appendix A – Profinet Signal and Packet Definitions.



4.3.3 TR Packet 1

TR Packet 1			
Data name	Type	Description (as a complement to Table 4-1)	Byte.Bit Offset
TR_OBU_TrainSleep	BOOLEAN1		0.0
TR_OBU_TrainSleep_Not	BOOLEAN1		0.1
TR_OBU_PassiveShunting	BOOLEAN1		0.2
TR_OBU_NLEnabled	BOOLEAN1		0.3
TR_OBU_DirectionFW	BOOLEAN1		0.4
TR_OBU_DirectionBW	BOOLEAN1		0.5
TR_OBU_CabStatusA	BOOLEAN1		0.6
TR_OBU_CabStatusB	BOOLEAN1		0.7
TR_OBU_TypeTrainData_S1	BOOLEAN1		1.0
TR_OBU_TypeTrainData_S2	BOOLEAN1		1.1
Spare1	BOOLEAN1		1.2
Spare2	BOOLEAN1		1.3
TR_OBU_Traction_Status	BOOLEAN1		1.4
Spare3	BOOLEAN1		1.5
TR_OBU_SetSpeedDisplay	BOOLEAN1		1.6

© This document has been developed and released by UNISIG in collaboration with Faiveley Transport, Knorr-Bremse, TÜV, Voith Turbo and Vossloh



TR Packet 1			
Data name	Type	Description (as a complement to Table 4-1)	Byte.Bit Offset
Spare4	BOOLEAN1		1.7
TR_OBU_BrakePressure	UNSIGNED8		2.0
TR_OBU_Brake_Status	BITSET8		3.0
TR_OBU_NTClolated	UNSIGNED16		4.0
TR_OBU_SetSpeedValue	UNSIGNED16		6.0
TR_OBU_NTClolated_Not	UNSIGNED16		8.0
Spare5	UNSIGNED16		10.0
Spare6	UNSIGNED16		12.0
Spare7	UNSIGNED16		14.0
Spare8	UNSIGNED16		16.0
Spare9	UNSIGNED16		18.0
Spare10	UNSIGNED16		20.0
Validity1	UNSIGNED16	Validity of value of variables contained in the first two bytes of the packet. The validity of the signal with offset 0.0 is in bit 0. The validity of the signal with offset 1.0 is in bit 8. The validity of the signal with offset 1.7 is in bit 15.	22.0
Validity2	UNSIGNED16	Validity of value of variables contained in bytes 2 to 21 of the packet. The validity of the signal with offset 2.0 is in bit 0. The validity of the signal with offset 20.0 is in bit 11.	24.0

© This document has been developed and released by UNISIG in collaboration with Faiveley Transport, Knorr-Bremse, TÜV, Voith Turbo and Vossloh



4.3.4 TR Packet 2

TR Packet 2			
Data name	Type	Description (as a complement to Table 4-1)	Byte.Bit Offset
Spare1	BOOLEAN1		0.0
Spare2	BOOLEAN1		0.1
TR_OBU_BrakePosition1	BOOLEAN1		0.2
TR_OBU_BrakePosition1_Not	BOOLEAN1		0.3
TR_OBU_BrakePosition2	BOOLEAN1		0.4
TR_OBU_BrakePosition2_Not	BOOLEAN1		0.5
TR_OBU_AirTightFitted	BOOLEAN1		0.6
Spare3	BOOLEAN1		0.7
Spare4	UNSIGNED8		1.0
TR_OBU_TypeTrainConfiguration	UNSIGNED8		2.0
TR_OBU_BrakePercentage	UNSIGNED8		3.0
Spare5	UNSIGNED16		4.0
TR_OBU_TrainLength	UNSIGNED16		6.0
TR_OBU_LoadingGauge	UNSIGNED8		8.0
TR_OBU_AxleLoadCat	UNSIGNED8		9.0
TR_OBU_TrainCatCantDef	UNSIGNED8		10.0

© This document has been developed and released by UNISIG in collaboration with Faiveley Transport, Knorr-Bremse, TÜV, Voith Turbo and Vossloh



TR Packet 2			
Data name	Type	Description (as a complement to Table 4-1)	Byte.Bit Offset
TR_OBU_TrainIntegrity_S1	BOOLEAN1		11.0
TR_OBU_TrainIntegrity_S1_Not	BOOLEAN1		11.1
TR_OBU_TrainIntegrity_S2	BOOLEAN1		11.2
TR_OBU_TrainIntegrity_S2_Not	BOOLEAN1		11.3
Spare6	BOOLEAN1		11.4
Spare7	BOOLEAN1		11.5
Spare8	BOOLEAN1		11.6
Spare9	BOOLEAN1		11.7
TR_OBU_SupTractionSys	UNSIGNED32		12.0
TR_OBU_NID_OPERATIONAL	UNSIGNED32		16.0
Spare10	UNSIGNED16		20.0
Validity1	UNSIGNED16	Validity of value of variables contained in bytes 0 to 10 of the packet. The validity of the signal with offset 0.0 is in bit 0. The validity of the signal with offset 1.0 is in bit 8. The validity of the signal with offset 10.0 is in bit 15.	22.0
Validity2	UNSIGNED16	Validity of value of variables contained in bytes 11 to 20 of the packet. The validity of the signal with offset 11.0 is in bit 0. The validity of the signal with offset 20.0 is in bit 10.	24.0

© This document has been developed and released by UNISIG in collaboration with Faiveley Transport, Knorr-Bremse, TÜV, Voith Turbo and Vossloh



4.3.5 TR Packet 3

TR Packet 3			
Data name	Type	Description (as a complement to Table 4-1)	Byte.Bit Offset
TR_OBU_ L_CONSISTFRONTCABAMAX	UNSIGNED16		0.0
TR_OBU_ L_CONSISTFRONTCABAMIN	UNSIGNED16		2.0
TR_OBU_ L_CONSISTFRONTCABANOM	UNSIGNED16		4.0
TR_OBU_ L_CONSISTREARCABAMAX	UNSIGNED16		6.0
TR_OBU_ L_CONSISTREARCABAMIN	UNSIGNED16		8.0
TR_OBU_ L_CONSISTREARCABANOM	UNSIGNED16		10.0
Spare1	UNSIGNED16		12.0
Spare2	UNSIGNED16		14.0
Spare3	UNSIGNED16		16.0
Spare4	UNSIGNED16		18.0
Spare5	UNSIGNED16		20.0
Spare6	UNSIGNED16		22.0

© This document has been developed and released by UNISIG in collaboration with Faiveley Transport, Knorr-Bremse, TÜV, Voith Turbo and Vossloh



TR Packet 3			
Data name	Type	Description (as a complement to Table 4-1)	Byte.Bit Offset
Validity	UNSIGNED16	Validity of value of variables contained in bytes 0 to 11 of the packet. The validity of the signal with offset 0.0 is in bit 0. The validity of the signal with offset 22.0 is in bit 11.	24.0

4.3.6 Variables for Generic Packet Structures

- 4.3.6.1 The OBU packets 1 to 2 shall have a static packet structure, see clause 5.3.1.2. The OBU packets 3 to 7 shall have a generic packet structure, see clause 5.3.1.2.
- 4.3.6.2 The track conditions which shall be transmitted with generic packet structure (see clause 5.3.1.2) have the same data structure.
- 4.3.6.3 Coding for variables used for generic packet structures

Name	Size	Meaning
OBU_TR_TC_ID1, OBU_TR_TC_ID2, OBU_TR_TC_ID3, OBU_TR_TC_ID4, OBU_TR_TC_ID5, OBU_TR_TC_ID6, OBU_TR_TC_ID7, OBU_TR_TC_ID8, OBU_TR_TC_ID9,	8 bits	Track condition ID. The purpose of the track condition ID is to be able to distinguish more easily the track conditions to be transmitted among themselves. 0x00 to 0xFF are set for track conditions which are transmitted. For the next track condition to be transmitted the next value

© This document has been developed and released by UNISIG in collaboration with Faiveley Transport, Knorr-Bremse, TÜV, Voith Turbo and Vossloh



<p>OBU_TR_TC_ID10, OBU_TR_TC_ID11, OBU_TR_TC_ID12, OBU_TR_TC_ID13, OBU_TR_TC_ID14, OBU_TR_TC_ID15, OBU_TR_TC_ID16, OBU_TR_TC_ID17, OBU_TR_TC_ID18, OBU_TR_TC_ID19, OBU_TR_TC_ID20</p>		<p>shall be set. The Track condition ID of one track condition shall not change as long as this track condition is transmitted. Note: this means that if, while the OBU is transmitting a track condition and a track condition ID becomes free (this ID was used for the transmission of another track condition which transmission is now terminated), the OBU will continue the transmission of this track condition keeping the same ID, even if the new free ID has a lower value than the currently used one.</p>
<p>OBU_TR_TC_TYPE1, OBU_TR_TC_TYPE2, OBU_TR_TC_TYPE3, OBU_TR_TC_TYPE4, OBU_TR_TC_TYPE5, OBU_TR_TC_TYPE6, OBU_TR_TC_TYPE7, OBU_TR_TC_TYPE8, OBU_TR_TC_TYPE9, OBU_TR_TC_TYPE10, OBU_TR_TC_TYPE11, OBU_TR_TC_TYPE12, OBU_TR_TC_TYPE13, OBU_TR_TC_TYPE14, OBU_TR_TC_TYPE15,</p>	<p>8 bits</p>	<p>Track Condition Type.</p> <p>For each type of track condition there is an unambiguous value. The used value indicates which type of track condition is transmitted.</p> <p>The values are defined in Table 4-3.</p>



OBU_TR_TC_TYPE16, OBU_TR_TC_TYPE17, OBU_TR_TC_TYPE18, OBU_TR_TC_TYPE19, OBU_TR_TC_TYPE20		
OBU_TR_D_ENTRY1, OBU_TR_D_ENTRY2, OBU_TR_D_ENTRY3, OBU_TR_D_ENTRY4, OBU_TR_D_ENTRY5, OBU_TR_D_ENTRY6, OBU_TR_D_ENTRY7, OBU_TR_D_ENTRY8, OBU_TR_D_ENTRY9, OBU_TR_D_ENTRY10, OBU_TR_D_ENTRY11, OBU_TR_D_ENTRY12, OBU_TR_D_ENTRY13, OBU_TR_D_ENTRY14, OBU_TR_D_ENTRY15, OBU_TR_D_ENTRY16, OBU_TR_D_ENTRY17, OBU_TR_D_ENTRY18, OBU_TR_D_ENTRY19, OBU_TR_D_ENTRY20	16 bits	Remaining distance to the start location point D (OBU_TR_XXX_D_Entry) for the respective Track Condition Type, see Table 5-23.
OBU_TR_D_EXIT1, OBU_TR_D_EXIT2,	16 bits	Remaining distance to the end location point E (OBU_TR_XXX_D_Exit) for the

© This document has been developed and released by UNISIG in collaboration with Faiveley Transport, Knorr-Bremse, TÜV, Voith Turbo and Vossloh

OBU_TR_D_EXIT3, OBU_TR_D_EXIT4, OBU_TR_D_EXIT5, OBU_TR_D_EXIT6, OBU_TR_D_EXIT7, OBU_TR_D_EXIT8, OBU_TR_D_EXIT9, OBU_TR_D_EXIT10, OBU_TR_D_EXIT11, OBU_TR_D_EXIT12, OBU_TR_D_EXIT13, OBU_TR_D_EXIT14, OBU_TR_D_EXIT15, OBU_TR_D_EXIT16, OBU_TR_D_EXIT17, OBU_TR_D_EXIT18, OBU_TR_D_EXIT19, OBU_TR_D_EXIT20		respective Track Condition Type, see Table 5-24.
--	--	--

Table 4-2 Coding for Variables used for Generic Packet Structures

4.3.6.4 If with track condition variables no track condition information is transmitted the respective validity bit shall be set to “0”.

4.3.6.5 Meaning of the Track Condition Type Values and the relation to Track Condition Distance Variables

Value of OBU_TR_TC_TYPEx x	Type of Track Condition / Meaning	Variable to be allocated to OBU_TR_D_ENTRYxx	Variable to be allocated to OBU_TR_D_EXITxx
---	--	---	--



0x00	Regenerative Brake Inhibition	OBU_TR_RBI_D_Entry	OBU_TR_RBI_D_Exit
0x01	Magnetic Shoe Brake Inhibition	OBU_TR_MGI_D_Entry	OBU_TR_MGI_D_Exit
0x02	Eddy Current Brake for SB Inhibition	OBU_TR_ECS_D_Entry	OBU_TR_ECS_D_Exit
0x03	Eddy Current Brake for EB Inhibition	OBU_TR_ECE_D_Entry	OBU_TR_ECE_D_Exit
0x04	Air Tightness Section	OBU_TR_AT_D_Entry	OBU_TR_AT_D_Exit
0x05	Powerless Section with Pantograph to be Lowered	OBU_TR_PG_D_Entry	OBU_TR_PG_D_Exit
0x06	Powerless Section with Main Power switch to be Switched Off	OBU_TR_MPS_D_Entry	OBU_TR_MPS_D_Exit
0x07 to 0xFF	Spare values	-	-

Table 4-3 Meaning of Track Condition Type Values

4.3.6.6 Note: There is a simple indication of going back to initial state or keep the current setting for the track conditions which consists in stopping to provide information for this track condition, which means sending the special value “8000h” for the remaining distance to



the start and end location or to the location of change according to §5.3.1.12. This applies for the transmission with the static packet structure and also with the generic packet structure.

4.3.7 OBU Packet 1

OBU Packet 1			
Data name	Type	Description (as a complement to Table 4-1)	Byte.Bit Offset
OBU_TR_ServiceBrake	BOOLEAN1		0.0
OBU_TR_EB3_Cmd	BOOLEAN1		0.1
OBU_TR_TCO_Cmd	BOOLEAN1		0.2
OBU_TR_RBInhibit_Cmd	BOOLEAN1		0.3
OBU_TR_MGInhibit_Cmd	BOOLEAN1		0.4
OBU_TR_ECSEInhibit_Cmd	BOOLEAN1		0.5
OBU_TR_ECEInhibit_Cmd	BOOLEAN1		0.6
OBU_TR_AT_Cmd	BOOLEAN1		0.7
OBU_TR_MPS_Cmd	BOOLEAN1		1.0
OBU_TR_PG_Cmd	BOOLEAN1		1.1
OBU_TR_AD_Status	BOOLEAN1		1.2
OBU_TR_RS_Status	BOOLEAN1		1.3
Spare1	BOOLEAN1		1.4

© This document has been developed and released by UNISIG in collaboration with Faiveley Transport, Knorr-Bremse, TÜV, Voith Turbo and Vossloh



OBU Packet 1			
Data name	Type	Description (as a complement to Table 4-1)	Byte.Bit Offset
Spare2	BOOLEAN1		1.5
Spare3	BOOLEAN1		1.6
OBU_TR_EngOrientSM	BOOLEAN1		1.7
Spare4	UNSIGNED16		2.0
OBU_TR_CTS_D_Change	INTEGER16	Change of Traction System	4.0
OBU_TR_CTS_NewId	UNSIGNED16		6.0
OBU_TR_CTS_NewVoltage	UNSIGNED8		8.0
Spare5	UNSIGNED8		9.0
OBU_TR_ACC_D_Change	INTEGER16	Change of Allowed Current Consumption	10.0
OBU_TR_ACC_Limit	UNSIGNED16		12.0
Spare6	UNSIGNED16		14.0
Spare7	UNSIGNED16		16.0
Spare8	UNSIGNED16		18.0
Spare9	UNSIGNED16		20.0
Validity1	UNSIGNED16	Validity of value of variables contained in the first two bytes of the packet. The validity of the signal with offset 0.0 is in bit 0. The validity of the signal with offset 1.0 is in bit 8. The validity of the signal with offset 1.7 is in bit 15.	22.0

© This document has been developed and released by UNISIG in collaboration with Faiveley Transport, Knorr-Bremse, TÜV, Voith Turbo and Vossloh



OBU Packet 1			
Data name	Type	Description (as a complement to Table 4-1)	Byte.Bit Offset
Validity2	UNSIGNED16	Validity of value of variables contained in bytes 2 to 19 of the packet. The validity of the 1 st signal with offset 2.0 is in bit 0. The validity of the signal with offset 20.0 is in bit 10.	24.0



4.3.8 OBU Station Platform (OBU Packet 2)

OBU Station Platform			
Data name	Type	Description (as a complement to Table 4-1)	Byte.Bit Offset
Validity1	BOOLEAN1	Variables for element 1 are used	0.0
Validity2	BOOLEAN1	Variables for element 2 are used	0.1
Validity3	BOOLEAN1	Variables for element 3 are used	0.2
Validity4	BOOLEAN1	Variables for element 4 are used	0.3
Validity5	BOOLEAN1	Variables for element 5 are used	0.4
Spare1	BOOLEAN1	-	0.5
Spare2	BOOLEAN1	-	0.6
Spare3	BOOLEAN1	-	0.7
OBU_TR_SP_Left1	BOOLEAN1		1.0
OBU_TR_SP_Right1	BOOLEAN1		1.1
Spare4	BOOLEAN1		1.2
Spare5	BOOLEAN1		1.3
OBU_TR_SP_Height1_Bit0	BOOLEAN1		1.4
OBU_TR_SP_Height1_Bit1	BOOLEAN1		1.5
OBU_TR_SP_Height1_Bit2	BOOLEAN1		1.6
OBU_TR_SP_Height1_Bit3	BOOLEAN1		1.7

© This document has been developed and released by UNISIG in collaboration with Faiveley Transport, Knorr-Bremse, TÜV, Voith Turbo and Vossloh



OBU Station Platform			
Data name	Type	Description (as a complement to Table 4-1)	Byte.Bit Offset
OBU_TR_SP_Left2	BOOLEAN1		2.0
OBU_TR_SP_Right2	BOOLEAN1		2.1
Spare6	BOOLEAN1		2.2
Spare7	BOOLEAN1		2.3
OBU_TR_SP_Height2_Bit0	BOOLEAN1		2.4
OBU_TR_SP_Height2_Bit1	BOOLEAN1		2.5
OBU_TR_SP_Height2_Bit2	BOOLEAN1		2.6
OBU_TR_SP_Height2_Bit3	BOOLEAN1		2.7
OBU_TR_SP_Left3	BOOLEAN1		3.0
OBU_TR_SP_Right3	BOOLEAN1		3.1
Spare8	BOOLEAN1		3.2
Spare9	BOOLEAN1		3.3
OBU_TR_SP_Height3_Bit0	BOOLEAN1		3.4
OBU_TR_SP_Height3_Bit1	BOOLEAN1		3.5
OBU_TR_SP_Height3_Bit2	BOOLEAN1		3.6
OBU_TR_SP_Height3_Bit3	BOOLEAN1		3.7
OBU_TR_SP_Left4	BOOLEAN1		4.0
OBU_TR_SP_Right4	BOOLEAN1		4.1

© This document has been developed and released by UNISIG in collaboration with Faiveley Transport, Knorr-Bremse, TÜV, Voith Turbo and Vossloh



OBU Station Platform			
Data name	Type	Description (as a complement to Table 4-1)	Byte.Bit Offset
Spare10	BOOLEAN1		4.2
Spare11	BOOLEAN1		4.3
OBU_TR_SP_Height4_Bit0	BOOLEAN1		4.4
OBU_TR_SP_Height4_Bit1	BOOLEAN1		4.5
OBU_TR_SP_Height4_Bit2	BOOLEAN1		4.6
OBU_TR_SP_Height4_Bit3	BOOLEAN1		4.7
OBU_TR_SP_Left5	BOOLEAN1		5.0
OBU_TR_SP_Right5	BOOLEAN1		5.1
Spare12	BOOLEAN1		5.2
Spare13	BOOLEAN1		5.3
OBU_TR_SP_Height5_Bit0	BOOLEAN1		5.4
OBU_TR_SP_Height5_Bit1	BOOLEAN1		5.5
OBU_TR_SP_Height5_Bit2	BOOLEAN1		5.6
OBU_TR_SP_Height5_Bit3	BOOLEAN1		5.7
OBU_TR_SP_D_Entry1	INTEGER16		6.0
OBU_TR_SP_D_Exit1	INTEGER 16		8.0
OBU_TR_SP_D_Entry2	INTEGER16		10.0
OBU_TR_SP_D_Exit2	INTEGER 16		12.0

© This document has been developed and released by UNISIG in collaboration with Faiveley Transport, Knorr-Bremse, TÜV, Voith Turbo and Vossloh



OBU Station Platform			
Data name	Type	Description (as a complement to Table 4-1)	Byte.Bit Offset
OBU_TR_SP_D_Entry3	INTEGER16		14.0
OBU_TR_SP_D_Exit3	INTEGER 16		16.0
OBU_TR_SP_D_Entry4	INTEGER16		18.0
OBU_TR_SP_D_Exit4	INTEGER 16		20.0
OBU_TR_SP_D_Entry5	INTEGER16		22.0
OBU_TR_SP_D_Exit5	INTEGER 16		24.0

4.3.9 OBU Packet 3

OBU Packet 3				
Data name (structure and fixed generic content)	Type	Default values	Values per type of track condition	Byte.Bit Offset
OBU_TR_TC_ID1	UNSIGNED8	-	0x00 to 0xff	0.0
OBU_TR_TC_TYPE1	UNSIGNED8	-	0x00 to 0x06	1.0
OBU_TR_D_ENTRY1	INTEGER16	-	OBU_TR_xxx_D_Entry	2.0
OBU_TR_D_EXIT1	INTEGER16	-	OBU_TR_xxx_D_Exit	4.0
OBU_TR_TC_ID2	UNSIGNED8	-	0x00 to 0xff	6.0
OBU_TR_TC_TYPE2	UNSIGNED8	-	0x00 to 0x06	7.0

© This document has been developed and released by UNISIG in collaboration with Faiveley Transport, Knorr-Bremse, TÜV, Voith Turbo and Vossloh



OBU Packet 3				
Data name (structure and fixed generic content)	Type	Default values	Values per type of track condition	Byte.Bit Offset
OBU_TR_D_ENTRY2	INTEGER16	-	OBU_TR_xxx_D_Entry	8.0
OBU_TR_D_EXIT2	INTEGER16	-	OBU_TR_xxx_D_Exit	10.0
OBU_TR_TC_ID3	UNSIGNED8	-	0x00 to 0xff	12.0
OBU_TR_TC_TYPE3	UNSIGNED8	-	0x00 to 0x06	13.0
OBU_TR_D_ENTRY3	INTEGER16	-	OBU_TR_xxx_D_Entry	14.0
OBU_TR_D_EXIT3	INTEGER16	-	OBU_TR_xxx_D_Exit	16.0
OBU_TR_TC_ID4	UNSIGNED8	-	0x00 to 0xff	18.0
OBU_TR_TC_TYPE4	UNSIGNED8	-	0x00 to 0x06	19.0
OBU_TR_D_ENTRY4	INTEGER16	-	OBU_TR_xxx_D_Entry	20.0
OBU_TR_D_EXIT4	INTEGER16	-	OBU_TR_xxx_D_Exit	22.0
Validity	UNSIGNED16	-	Validity of value of variables contained in bytes 0 to 22 of the packet. The validity of the signal with offset 0.0 is in bit 0. The validity of the signal with offset 22.0 is in bit 15.	24.0



4.3.10 OBU Packet 4

OBU Packet 4				
Data name (structure and fixed generic content)	Type	Default values	Values per type of track condition	Byte.Bit Offset
OBU_TR_TC_ID5	UNSIGNED8	-	0x00 to 0xff	0.0
OBU_TR_TC_TYPE5	UNSIGNED8	-	0x00 to 0x06	1.0
OBU_TR_D_ENTRY5	INTEGER16	-	OBU_TR_xxx_D_Entry	2.0
OBU_TR_D_EXIT5	INTEGER16	-	OBU_TR_xxx_D_Exit	4.0
OBU_TR_TC_ID6	UNSIGNED8	-	0x00 to 0xff	6.0
OBU_TR_TC_TYPE6	UNSIGNED8	-	0x00 to 0x06	7.0
OBU_TR_D_ENTRY6	INTEGER16	-	OBU_TR_xxx_D_Entry	8.0
OBU_TR_D_EXIT6	INTEGER16	-	OBU_TR_xxx_D_Exit	10.0
OBU_TR_TC_ID7	UNSIGNED8	-	0x00 to 0xff	12.0
OBU_TR_TC_TYPE7	UNSIGNED8	-	0x00 to 0x06	13.0
OBU_TR_D_ENTRY7	INTEGER16	-	OBU_TR_xxx_D_Entry	14.0
OBU_TR_D_EXIT7	INTEGER16	-	OBU_TR_xxx_D_Exit	16.0
OBU_TR_TC_ID8	UNSIGNED8	-	0x00 to 0xff	18.0
OBU_TR_TC_TYPE8	UNSIGNED8	-	0x00 to 0x06	19.0
OBU_TR_D_ENTRY8	INTEGER16	-	OBU_TR_xxx_D_Entry	20.0
OBU_TR_D_EXIT8	INTEGER16	-	OBU_TR_xxx_D_Exit	22.0

© This document has been developed and released by UNISIG in collaboration with Faiveley Transport, Knorr-Bremse, TÜV, Voith Turbo and Vossloh



OBU Packet 4				
Data name (structure and fixed generic content)	Type	Default values	Values per type of track condition	Byte.Bit Offset
Validity	UNSIGNED16	-	Validity of value of variables contained in bytes 0 to 22 of the packet. The validity of the signal with offset 0.0 is in bit 0. The validity of the signal with offset 22.0 is in bit 16.	24.0

4.3.11 OBU Packet 5

OBU Packet 5				
Data name (structure and fixed generic content)	Type	Default values	Values per type of track condition	Byte.Bit Offset
OBU_TR_TC_ID9	UNSIGNED8	-	0x00 to 0xff	0.0
OBU_TR_TC_TYPE9	UNSIGNED8	-	0x00 to 0x06	1.0
OBU_TR_D_ENTRY9	INTEGER16	-	OBU_TR_xxx_D_Entry	2.0
OBU_TR_D_EXIT9	INTEGER16	-	OBU_TR_xxx_D_Exit	4.0
OBU_TR_TC_ID10	UNSIGNED8	-	0x00 to 0xff	6.0
OBU_TR_TC_TYPE10	UNSIGNED8	-	0x00 to 0x06	7.0
OBU_TR_D_ENTRY10	INTEGER16	-	OBU_TR_xxx_D_Entry	8.0
OBU_TR_D_EXIT10	INTEGER16	-	OBU_TR_xxx_D_Exit	10.0

© This document has been developed and released by UNISIG in collaboration with Faiveley Transport, Knorr-Bremse, TÜV, Voith Turbo and Vossloh



OBU Packet 5				
Data name (structure and fixed generic content)	Type	Default values	Values per type of track condition	Byte.Bit Offset
OBU_TR_TC_ID11	UNSIGNED8	-	0x00 to 0xff	12.0
OBU_TR_TC_TYPE11	UNSIGNED8	-	0x00 to 0x06	13.0
OBU_TR_D_ENTRY11	INTEGER16	-	OBU_TR_xxx_D_Entry	14.0
OBU_TR_D_EXIT11	INTEGER16	-	OBU_TR_xxx_D_Exit	16.0
OBU_TR_TC_ID12	UNSIGNED8	-	0x00 to 0xff	18.0
OBU_TR_TC_TYPE12	UNSIGNED8	-	0x00 to 0x06	19.0
OBU_TR_D_ENTRY12	INTEGER16	-	OBU_TR_xxx_D_Entry	20.0
OBU_TR_D_EXIT12	INTEGER16	-	OBU_TR_xxx_D_Exit	22.0
Validity	UNSIGNED16	-	Validity of value of variables contained in bytes 0 to 22 of the packet. The validity of the signal with offset 0.0 is in bit 0. The validity of the signal with offset 22.0 is in bit 15.	24.0



4.3.12 OBU Packet 6

OBU Packet 6				
Data name (structure and fixed generic content)	Type	Default values	Values per type of track condition	Byte.Bit Offset
OBU_TR_TC_ID13	UNSIGNED8	-	0x00 to 0xff	0.0
OBU_TR_TC_TYPE13	UNSIGNED8	-	0x00 to 0x06	1.0
OBU_TR_D_ENTRY13	INTEGER16	-	OBU_TR_xxx_D_Entry	2.0
OBU_TR_D_EXIT13	INTEGER16	-	OBU_TR_xxx_D_Exit	4.0
OBU_TR_TC_ID14	UNSIGNED8	-	0x00 to 0xff	6.0
OBU_TR_TC_TYPE14	UNSIGNED8	-	0x00 to 0x06	7.0
OBU_TR_D_ENTRY14	INTEGER16	-	OBU_TR_xxx_D_Entry	8.0
OBU_TR_D_EXIT14	INTEGER16	-	OBU_TR_xxx_D_Exit	10.0
OBU_TR_TC_ID15	UNSIGNED8	-	0x00 to 0xff	12.0
OBU_TR_TC_TYPE15	UNSIGNED8	-	0x00 to 0x06	13.0
OBU_TR_D_ENTRY15	INTEGER16	-	OBU_TR_xxx_D_Entry	14.0
OBU_TR_D_EXIT15	INTEGER16	-	OBU_TR_xxx_D_Exit	16.0
OBU_TR_TC_ID16	UNSIGNED8	-	0x00 to 0xff	18.0
OBU_TR_TC_TYPE16	UNSIGNED8	-	0x00 to 0x06	19.0
OBU_TR_D_ENTRY16	INTEGER16	-	OBU_TR_xxx_D_Entry	20.0
OBU_TR_D_EXIT16	INTEGER16	-	OBU_TR_xxx_D_Exit	22.0

© This document has been developed and released by UNISIG in collaboration with Faiveley Transport, Knorr-Bremse, TÜV, Voith Turbo and Vossloh



OBU Packet 6				
Data name (structure and fixed generic content)	Type	Default values	Values per type of track condition	Byte.Bit Offset
Validity	UNSIGNED16	-	Validity of value of variables contained in bytes 0 to 22 of the packet. The validity of the signal with offset 0.0 is in bit 0. The validity of the signal with offset 22.0 is in bit 15.	24.0

4.3.13 OBU Packet 7

OBU Packet 7				
Data name (structure and fixed generic content)	Type	Default values	Values per type of track condition	Byte.Bit Offset
OBU_TR_TC_ID17	UNSIGNED8	-	0x00 to 0xff	0.0
OBU_TR_TC_TYPE17	UNSIGNED8	-	0x00 to 0x06	1.0
OBU_TR_D_ENTRY17	INTEGER16	-	OBU_TR_xxx_D_Entry	2.0
OBU_TR_D_EXIT17	INTEGER16	-	OBU_TR_xxx_D_Exit	4.0
OBU_TR_TC_ID18	UNSIGNED8	-	0x00 to 0xff	6.0
OBU_TR_TC_TYPE18	UNSIGNED8	-	0x00 to 0x06	7.0
OBU_TR_D_ENTRY18	INTEGER16	-	OBU_TR_xxx_D_Entry	8.0
OBU_TR_D_EXIT18	INTEGER16	-	OBU_TR_xxx_D_Exit	10.0

© This document has been developed and released by UNISIG in collaboration with Faiveley Transport, Knorr-Bremse, TÜV, Voith Turbo and Vossloh



OBU Packet 7				
Data name (structure and fixed generic content)	Type	Default values	Values per type of track condition	Byte.Bit Offset
OBU_TR_TC_ID19	UNSIGNED8	-	0x00 to 0xff	12.0
OBU_TR_TC_TYPE19	UNSIGNED8	-	0x00 to 0x06	13.0
OBU_TR_D_ENTRY19	INTEGER16	-	OBU_TR_xxx_D_Entry	14.0
OBU_TR_D_EXIT19	INTEGER16	-	OBU_TR_xxx_D_Exit	16.0
OBU_TR_TC_ID20	UNSIGNED8	-	0x00 to 0xff	18.0
OBU_TR_TC_TYPE20	UNSIGNED8	-	0x00 to 0x06	19.0
OBU_TR_D_ENTRY20	INTEGER16	-	OBU_TR_xxx_D_Entry	20.0
OBU_TR_D_EXIT20	INTEGER16	-	OBU_TR_xxx_D_Exit	22.0
Validity	UNSIGNED16	-	Validity of value of variables contained in bytes 0 to 22 of the packet. The validity of the signal with offset 0.0 is in bit 0. The validity of the signal with offset 22.0 is in bit 15.	24.0

4.4 MVB

4.4.1 General

4.4.1.1 The lower communication layers are specified in [14].

4.4.1.2 In case of architecture b) (see 4.2.3) the safe data transmission shall be implemented in accordance with [17], Appendix B. Note: Only the packet part which is termed as “send telegram” in [17], figure B.13 “MVB-VDP” is defined in this Subset.

4.4.2 Data Properties and Application of the Safety Protocol

4.4.2.1 TR Packet 1

Properties:

Port address: configurable

Source device: TR

Sink device: OBU

Data class: Process data, 32 bytes

Maximum cycle time: 128 ms

TR Packet 1			
Data name	Type	Description	Byte.Bit Offset
Content according to TR Packet 1 (see chapter 4.3.3)			0.0
Safe data transmission trailer according to [17], Appendix B (in case of architecture b), see 4.2.3)			26.0

4.4.2.2 TR Packet 2

Properties:

Port address: configurable

Source device: TR

Sink device: OBU

Data class: Process data, 32 bytes

Maximum cycle time: 256 ms

TR Packet 2			
Data name	Type	Description	Byte.Bit Offset
Content according to TR Packet 2 (see chapter 4.3.4)			0.0
Safe data transmission trailer according to [17], Appendix B (in case of architecture b), see 4.2.3)			26.0

4.4.2.3 TR Packet 3

Properties:

Port address: configurable

Source device: TR

Sink device: OBU

Data class: Process data, 32 bytes

Maximum cycle time: 256 ms

TR Packet 3			
Data name	Type	Description	Byte.Bit Offset
Content according to TR Packet 3 (see chapter 4.3.5)			0.0
Safe data transmission trailer according to [17], Appendix B (in case of architecture b), see 4.2.3)			26.0

4.4.2.4 OBU Packet 1

Properties:

Port address: configurable

Source device: OBU

Sink device: TR

Data class: Process data, 32 bytes

Maximum cycle time: 128 ms

OBU Packet 1			
Data name	Type	Value Interpretation	Byte.Bit Offset
Content according to OBU Packet 1 (see chapter 4.3.7)			0.0
Safe data transmission trailer according to [17], Appendix B (in case of architecture b), see 4.2.3)			26.0

4.4.2.5 OBU Station Platform Packet (OBU Packet 2)

Properties:

Port address: configurable

Source device: OBU

Sink device: TR

Data class: Process data, 32 bytes

Maximum cycle time: 256 ms

OBU Station Platform			
Data name	Type	Value Interpretation	Byte.Bit Offset
Content according to OBU Station Platform (see chapter 4.3.8)			0.0
Safe data transmission trailer according to [17], Appendix B (in case of architecture b), see 4.2.3)			26.0

4.4.2.6 OBU Packet 3 to OBU Packet 7

Properties:

Port address: configurable

Source device: OBU

Sink device: TR

Data class: Process data, 32 bytes

Maximum cycle time: 256 ms

OBU Packet 3 ... OBU Packet 7			
Data name	Type	Value Interpretation	Byte.Bit Offset
Content according to OBU Packet 3 to OBU Packet 7 (see chapters 4.3.9 to 4.3.13)			0.0
Safe data transmission trailer according to [17], Appendix B (in case of architecture b), see 4.2.3)			26.0

4.5 CAN

4.5.1 General

4.5.1.1 The lower communications layers are specified in [14].

4.5.1.2 In case of architecture b) (see 4.2.3) the safe data transmission shall be implemented in accordance with [17], Appendix B (MVB).

4.5.1.2.1 An MVB packet shall be constructed at sender side to calculate the CRC and shall be split for transmission in 5 CAN packets, each with a different CAN packet identifier, see Figure 4-3.

4.5.1.2.2 At receiver side the CAN packets shall be merged again to an MVB packet to check the CRC.

4.5.1.2.3 All packets (CAN and MVB) of the same sequence shall use the same SSC value taken over from the MVB packet.

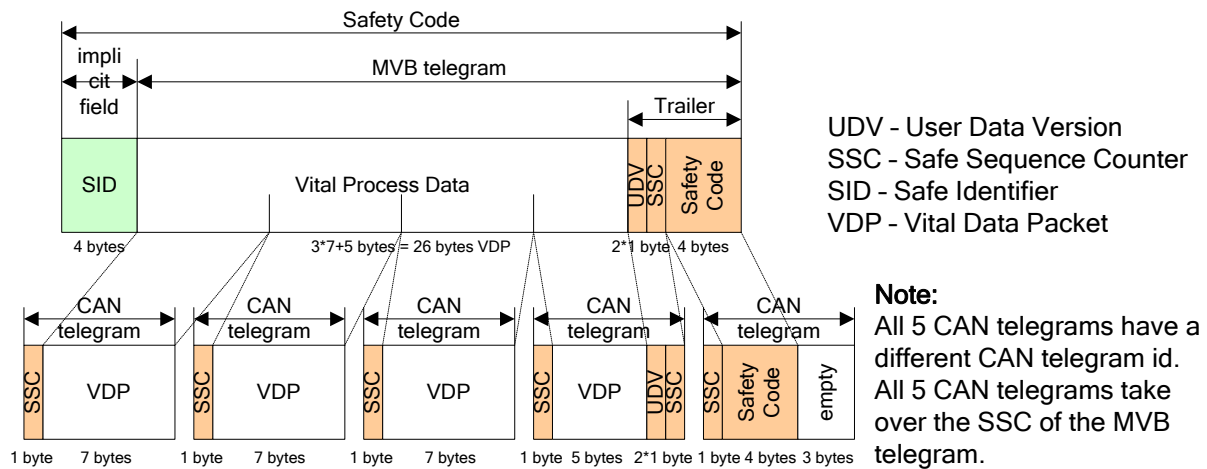

Figure 4-3 Safe Data Transmission via CAN

4.5.1.3 Note: Only the packet part which is termed as “send telegram” in [17], figure B.13 “MVB-VDP” is defined in this Subset.

4.5.2 Data Properties and Application of the Safety Protocol

4.5.2.1 CAN is using MVB coding, see chapter 4.4.2.

4.5.2.2 CAN packet numbers are configurable according to [19].

4.6 ECN

4.6.1 General

4.6.1.1 The lower communications layers are specified in [14].

4.6.1.2 In case of architecture b) (see 4.2.3) the safe data transmission shall be implemented in accordance with [17], Appendix B.

4.6.1.3 Note: The reference to SDTv2 covers only the safety protocol but it does not mean that embedding into TRDP is required.

4.6.1.4 Note: Only the packet part which is termed as “send telegram” in [17], figure B.6 “ETB-VDP” is defined in this Subset.

4.6.1.5 Note: SafeTopoCount is set to 0 as the network is only a Consist local communication network.

- 4.6.1.6 The value of cstUUID (unique consist identifier) shall be configured as a fixed value.
- 4.6.1.7 Exception: In case the optional safety protocol ProfiSafe according to IEC 61784-3-3 [22] is applied, the SDT trailer is replaced by the ProfiSafe trailer and appended directly to the data structures as defined in Appendix A, without any padding bytes.

4.6.2 Data Properties and Application of the Safety Protocol

4.6.2.1 TR Packet 1

Properties:

ComId: configurable

Source device: TR

Sink device: OBU

Data class: Process data

Maximum cycle time of source device: 100 ms

Dataset ID: configurable

TR Packet 1			
Data name	Type	Description	Byte.Bit Offset
Content according to TR Packet 1 (see chapter 4.3.3)			0.0
Padding	UNSIGNED16	SDT trailer needs to start at 4 byte alignment	26.0
Safe data transmission trailer according to [17], Appendix B (in case of architecture b), see 4.2.3)			28.0

4.6.2.2 TR Packet 2

Properties:

ComId: configurable

Source device: TR

Sink device: OBU

Data class: Process data

Maximum cycle time of source device: 200 ms

Dataset ID: configurable

TR Packet 2			
Data name	Type	Description	Byte.Bit Offset
Content according to TR Packet 2 (see chapter 4.3.4)			0.0
Padding	UNSIGNED16	SDT trailer needs to start at 4 byte alignment	26.0
Safe data transmission trailer according to [17], Appendix B (in case of architecture b), see 4.2.3)			28.0

4.6.2.3 TR Packet 3

Properties:

ComId: configurable

Source device: TR

Sink device: OBU

Data class: Process data

Maximum cycle time of source device: 200 ms

Dataset ID: configurable

TR Packet 3			
Data name	Type	Description	Byte.Bit Offset
Content according to TR Packet 3 (see chapter 4.3.5)			0.0
Padding	UNSIGNED16	SDT trailer needs to start at 4 byte alignment	26.0
Safe data transmission trailer according to [17], Appendix B (in case of architecture b), see 4.2.3)			28.0

4.6.2.4 OBU Packet 1

Properties:

ComId: configurable

Source device: OBU

Sink device: TR

Data class: Process data

Maximum cycle time of source device: 100 ms

Dataset ID: configurable

OBU Packet 1			
Data name	Type	Value Interpretation	Byte.Bit Offset
Content according to OBU Packet 1 (see chapter 4.3.7)			0.0
Padding	UNSIGNED16	SDT trailer needs to start at 4 byte alignment	26.0
Safe data transmission trailer according to [17], Appendix B (in case of architecture b), see 4.2.3)			28.0

4.6.2.5 OBU Station Platform Packet (OBU Packet 2)

Properties:

ComId: configurable

Source device: OBU

Sink device: TR

Data class: Process data

Maximum cycle time of source device: 200 ms

Dataset ID: configurable

OBU Station Platform			
Data name	Type	Value Interpretation	Byte.Bit Offset
Content according to OBU Packet 2 (see chapter 4.3.8)			0.0
Padding	UNSIGNED16	SDT trailer needs to start at 4 byte alignment	26.0
Safe data transmission trailer according to [17], Appendix B (in case of architecture b), see 4.2.3)			28.0

4.6.2.6 OBU Packet 3 to OBU Packet 7

Properties:

ComId: configurable

Source device: OBU

Sink device: TR

Data class: Process data

Maximum cycle time of source device: 200 ms

Dataset ID: configurable

OBU Packet 3 ... OBU Packet 7			
Data name	Type	Value Interpretation	Byte.Bit Offset
Content according to OBU Packet 3 to OBU Packet 7 (see chapters 4.3.9 to 4.3.13)			0.0
Padding	UNSIGNED16	SDT trailer needs to start at 4 byte alignment	26.0
Safe data transmission trailer according to [17], Appendix B (in case of architecture b), see 4.2.3)			28.0

5. REQUIREMENTS FOR THE SIGNALS TO BE EXCHANGED AT THE TRAIN INTERFACE

5.1 Mode Control

5.1.1 Sleeping

5.1.1.1 Architecture

5.1.1.1.1 Reference architecture as defined in Chapter 3 or serial connection (bus) as defined in Chapter 4 is allowed.

5.1.1.2 Coding

T_SL_E_N/ TR_OBU_TrainSleep	T_SL_E_I/ TR_OBU_TrainSleep_Not	Meaning
0	0	Invalid
0	1	Sleeping not requested
1	0	Sleeping requested
1	1	Invalid

Table 5-1 Coding for enable Sleeping function

5.1.1.3 Safety Requirements

5.1.1.3.1 Safety requirements shall apply as defined in [13], chapter 2.

5.1.2 Passive Shunting

5.1.2.1 Architecture

5.1.2.1.1 Reference architecture as defined in Chapter 3 or serial connection (bus) as defined in Chapter 4 is allowed.

5.1.2.2 Coding

T_PS_E/ TR_OBU_PassiveShunting	Meaning
0	Passive shunting not permitted
1	Passive shunting permitted

Table 5-2 Coding for Passive Shunting

5.1.2.3 Safety Requirements

5.1.2.3.1 Safety requirements shall apply as defined in [13], chapter 2.

5.1.3 Non Leading

5.1.3.1 Architecture

5.1.3.1.1 Reference architecture as defined in Chapter 3 or serial connection (bus) as defined in Chapter 4 is allowed.

5.1.3.2 Coding

T_NL_E / TR_OBU_NLEnabled	Meaning
0	Non-leading not permitted
1	Non-leading permitted

Table 5-3 Coding for Non Leading

5.1.3.3 Safety Requirements

5.1.3.3.1 Safety requirements shall apply as defined in [13], chapter 2.

5.1.4 Isolation

5.1.4.1 Architecture

5.1.4.1.1 Reference architecture as defined in Chapter 3 is allowed.

5.1.4.1.2 The signal shall be generated directly by the ERTMS/ETCS isolation device.

5.1.4.2 Coding

O_IS_S	Meaning
0	ERTMS/ETCS on-board not isolated
1	ERTMS/ETCS on-board isolated

Table 5-4 Coding for Isolation (of ETCS)

5.1.4.3 Safety Requirements

5.1.4.3.1 Safety requirements shall apply as defined in [13], chapter 2.

5.1.5 Automatic Driving

5.1.5.1 Architecture

5.1.5.1.1 Reference architecture as defined in Chapter 3 or serial connection (bus) as defined in Chapter 4 is allowed.

5.1.5.2 Coding

O_AD_S / OBU_TR_AD_Status	Meaning
0	ERTMS/ETCS on-board is not in AD mode
1	ERTMS/ETCS on-board is in AD mode

Table 5-5 Coding for Automatic Driving

5.1.5.2.1 Note: It is assumed that this output information is used for GOA2.

5.1.5.3 Safety Requirements

5.1.5.3.1 Safety requirements shall apply as defined in [13], chapter 2.

5.1.6 Remote Shunting

5.1.6.1 Architecture

5.1.6.1.1 Reference architecture as defined in Chapter 3 or serial connection (bus) as defined in Chapter 4 is allowed.

O_RS_S / OBU_TR_RS_Status	Meaning
0	ERTMS/ETCS on-board is not in a mode permitting remote shunting
1	ERTMS/ETCS on-board is in a mode permitting remote shunting

Table 5-6 Coding for Remote Shunting

5.1.6.2 Safety Requirements

5.1.6.2.1 Safety requirements shall apply as defined in [13], chapter 2.

5.2 Signals for the Control of Brakes

5.2.1 Service Brake Command

5.2.1.1 Architecture

5.2.1.1.1 Reference architecture as defined in Chapter 3 or serial connection (bus) as defined in Chapter 4 is allowed.

5.2.1.2 Coding

O_SB_C / OBU_TR_ServiceBrake	Meaning
0	Service brake not commanded
1	Service brake commanded

Table 5-7 Coding for Service Brake command

5.2.1.3 Safety Requirements

5.2.1.3.1 Safety requirements shall apply as defined in [13], chapter 2.

5.2.2 Brake Pressure

5.2.2.1 General

5.2.2.1.1 Note: The value of air pressure input represents either the pressure in the brake cylinders or in the UIC brake pipe, see [6], 2.3.2.3.1.

5.2.2.2 Architecture

5.2.2.2.1 Only serial connection (bus) as defined in Chapter 4 is allowed.

5.2.2.3 Coding

Name	Size	Meaning	
TR_OBU_BrakePressure	8 bits	0	0.0 bar
		1 ... 60	Steps of 0.1 bar up to 6 bar
		61 ... 255	Spare values

Table 5-8 Coding for Brake Pressure

5.2.2.4 Safety Requirements

5.2.2.4.1 Safety requirements shall apply as defined in [13], chapter 2.

5.2.3 Emergency Brake Interface

5.2.3.1 General

5.2.3.1.1 Two standard ways of transfer of the emergency brake command within the vehicle and train consist exist according to [5]:

- Electrical safety line (Figure 5-1)
- Pneumatic brake pipe according to (Figure 5-2)

5.2.3.2 Emergency Brake Command

5.2.3.2.1 Figure 5-1 shows a possible integration of an ERTMS/ETCS on-board on each end vehicle of a consist into an emergency brake architecture based on an electric safety line, where the emergency brake command is transmitted by de-energizing electric actors. Relays K1 and K2 are the transfer components.

5.2.3.2.1.1 Note: This is only a principle drawing not showing all details of the safety loop.

5.2.3.2.2 EB lines are redundant for safety reasons. The contacts of the ERTMS/ETCS on-board in each line shall be controlled separately in order to be able to test each line independently.

5.2.3.2.3 Notes to all figures: All contacts are drawn in position “no power” which corresponds to “EB commanded”. Actors 1, m and n are devices (valves, relays, electronic inputs of brake control etc.) either on one vehicle or distributed over the consist or distributed over the train. In addition, “ETCS” refers to ERTMS/ETCS on-board equipment.

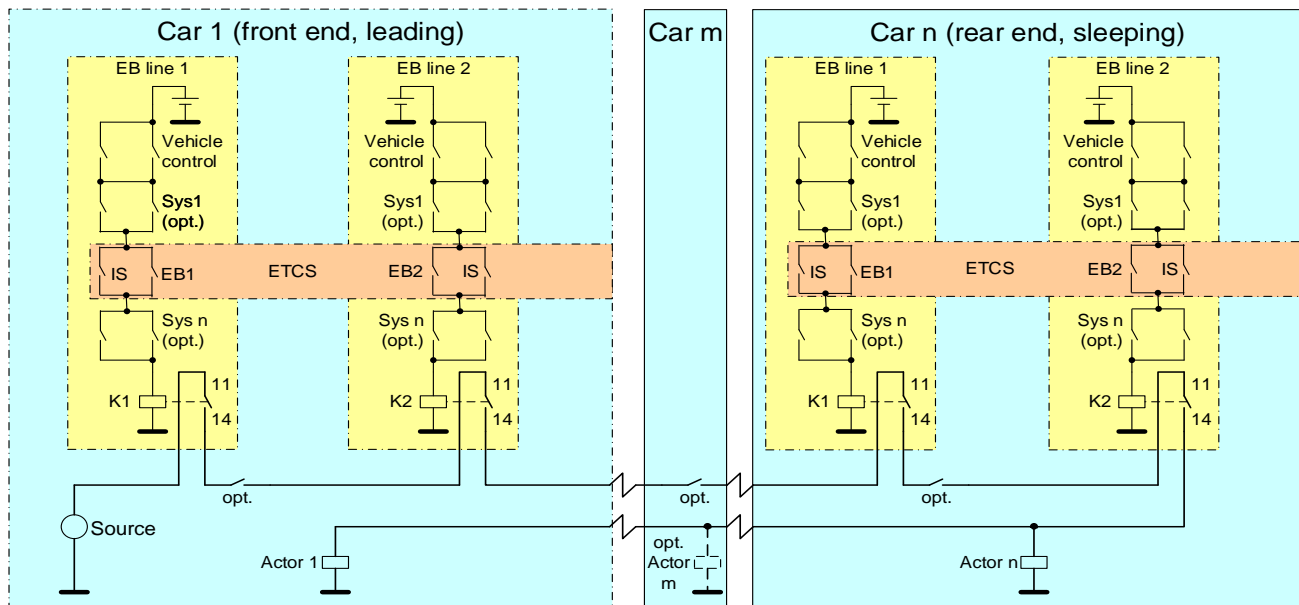

Figure 5-1 EB architecture example with electric safety loop

5.2.3.2.4 The following figure shows a possible integration of an ERTMS/ETCS on-board on each end vehicle into an emergency brake architecture based on a brake pipe where the emergency brake command is transmitted by venting a pneumatic pipe. In this architecture the transfer components are the valves controlled by the EB lines and venting the brake pipe.

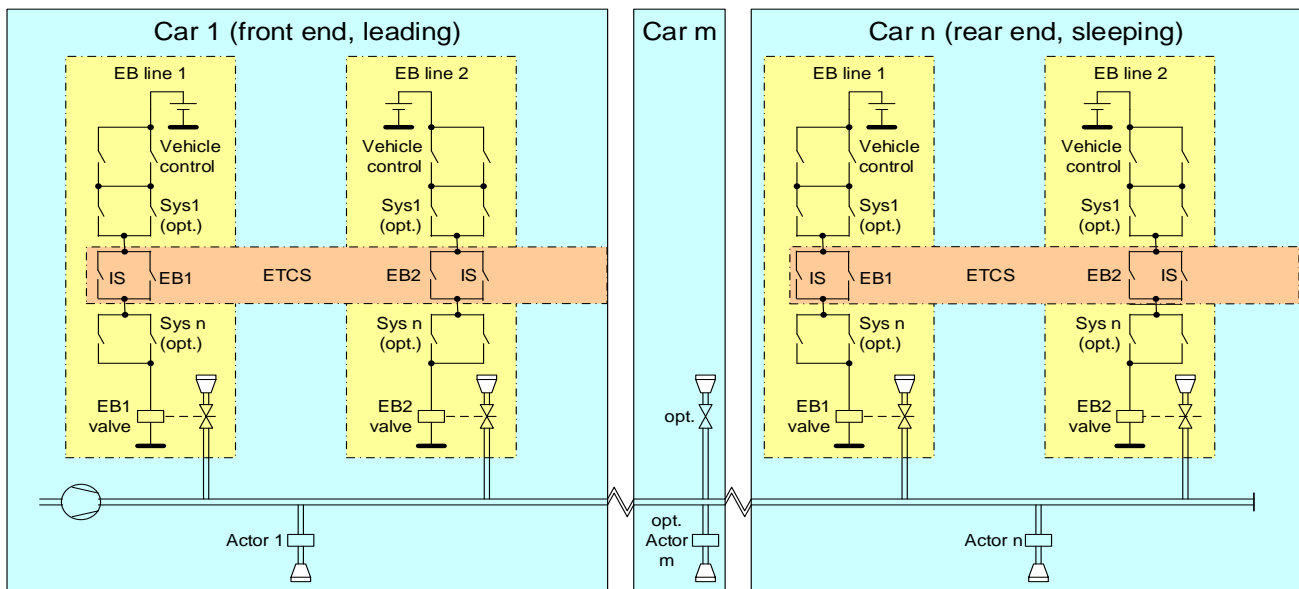

Figure 5-2 EB architecture example with brake pipe

5.2.3.2.5 The following figure shows another possible integration of an ERTMS/ETCS on-board on each end vehicle. The second EB line is implemented by using the serial interface to the Rolling Stock (e.g. TCMS). The further transmission from the Rolling Stock to the brake system is out of scope, but needs to be considered in the safety case (see safety requirements referenced in section 5.2.3.2.13)

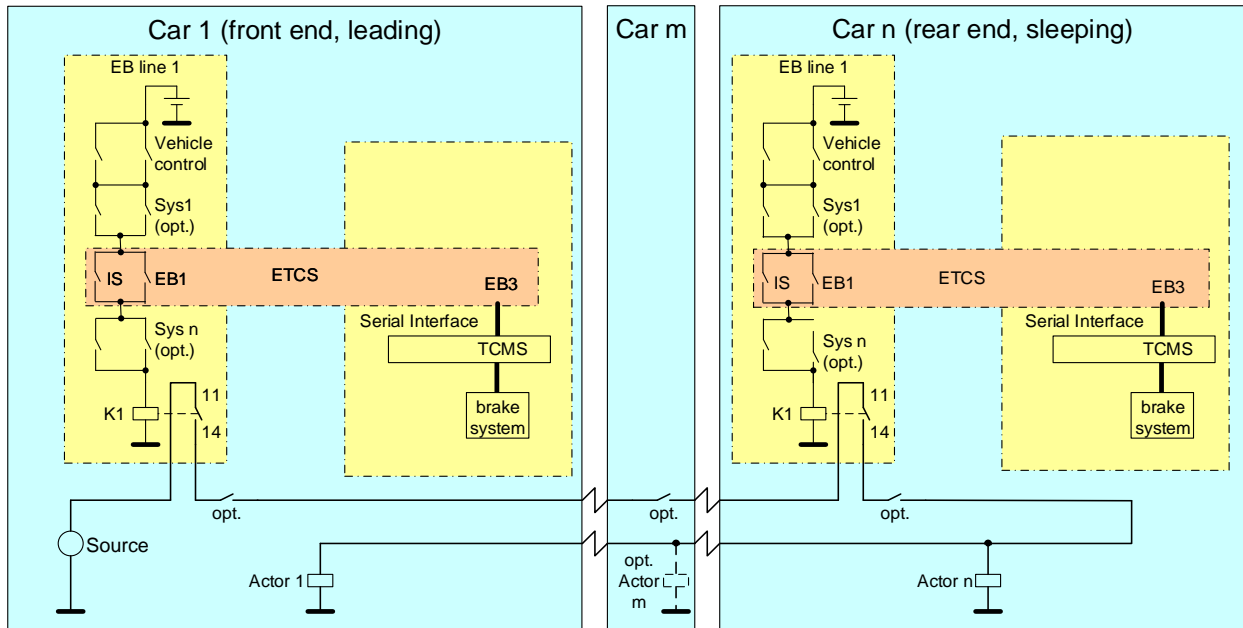

Figure 5-3 EB architecture example with one EB line and a serial link

- 5.2.3.2.6 In sections 5.2.3.2.7, 5.2.3.2.8 and 5.2.3.2.9 harmonized solutions for the EB command interface are defined.
- 5.2.3.2.7 Architecture Solution 1: Four NO contacts for two EB lines (see figure 5-4).
- 5.2.3.2.7.1 Architecture Solution 1 can be used for the architecture examples of Figure 5-1 and Figure 5-2.

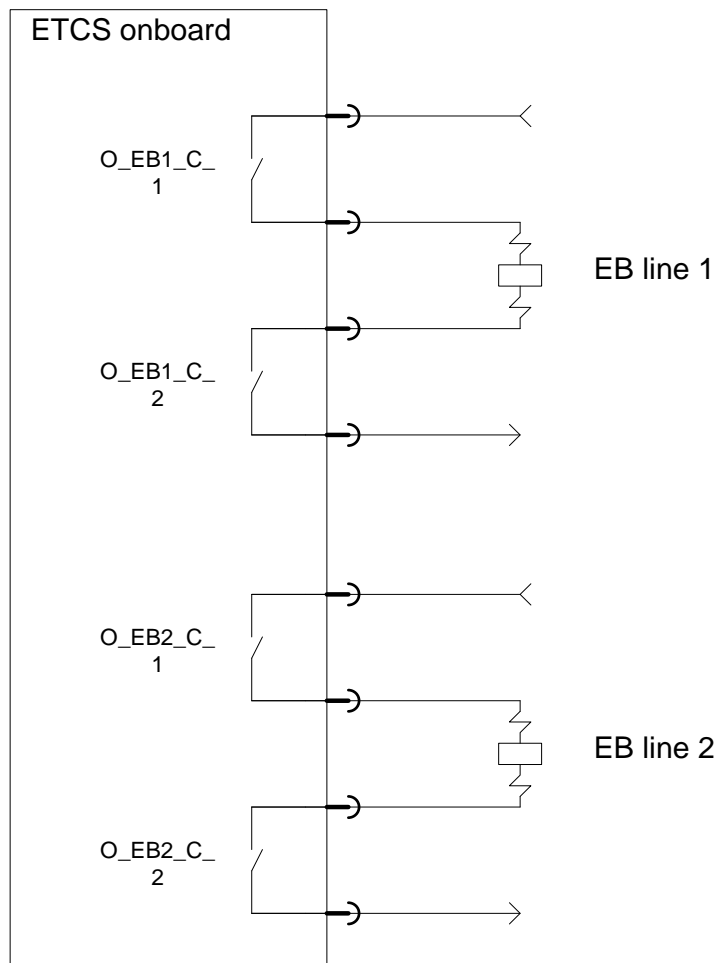

Figure 5-4 EB function, Solution 1: 2 EB lines

5.2.3.2.7.2 The contacts O_EB1_C_1 and O_EB1_C_2 are part of the same relay and form only one signal named O_EB1_C. O_EB2_C_1 and O_EB2_C_2 are part of another single relay and form another signal named O_EB2_C.

5.2.3.2.8 Architecture Solution 2: Two NO contacts for two EB lines (see figure 5-5).

5.2.3.2.8.1 Architecture Solution 2 can be used for the architecture examples of Figure 5-1 and Figure 5-2.

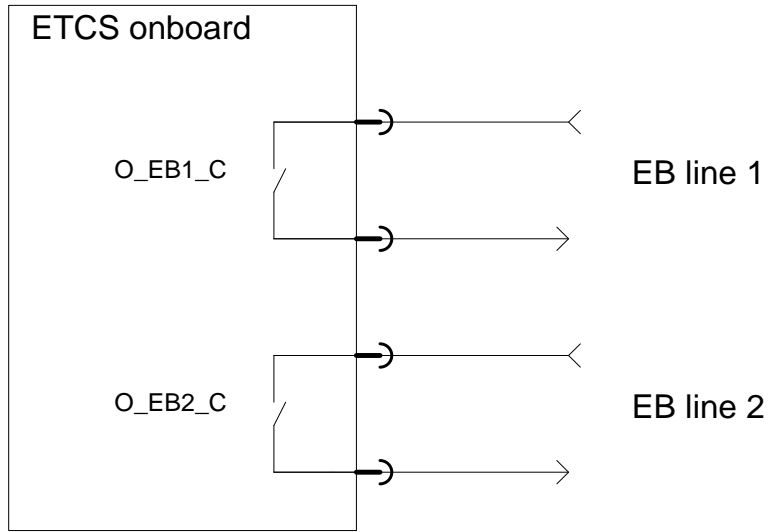

Figure 5-5 EB function, Solution 2: 2 EB lines

5.2.3.2.9 Architecture Solution 3: One NO contact for one EB line and serial interface (see figure 5-6).

5.2.3.2.9.1 Architecture Solution 3 can be used for the architecture examples of Figure 5-3.

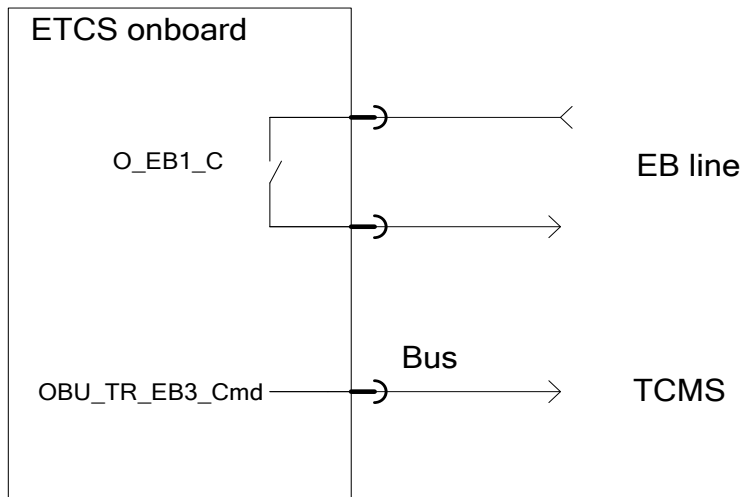

Figure 5-6 EB function, Solution 3: 1 EB line, serial interface

5.2.3.2.10 General Architecture

5.2.3.2.10.1 For O_EB1_C and O_EB2_C only reference architecture as defined in Chapter 3 is allowed.

5.2.3.2.11 For OBU_TR_EB3_Cmd only serial connection (bus) as defined in Chapter 4 is allowed.

5.2.3.2.12 Coding

O_EB1_C	O_EB2_C	Meaning
0	0	EB commanded
0	1	Fault in normal operation
1	0	Fault in normal operation
1	1	EB not commanded from ERTMS/ETCS on-board

Table 5-9 Coding for EB1 and EB2 command (solutions 1 and 2)

O_EB1_C	OBU_TR_EB3_Cmd	Meaning
0	0	EB commanded
0	1	Fault in normal operation
1	0	Fault in normal operation
1	1	EB not commanded from ERTMS/ETCS on-board

Table 5-10 Coding for EB1 and EB3 command (solution 3)

5.2.3.2.12.1 Vehicle shall apply EB in any cases in which the coding for “EB command” is different from O_EB1_C = 1 and O_EB2_C = 1 / OBU_TR_EB3_Cmd = 1.

5.2.3.2.12.2 Fault in normal operation is considered whenever the values of O_EB1_C and O_EB2_C / OBU_TR_EB3_Cmd remain different for a period greater than 2s. The failure has to be detected by the vehicle.

5.2.3.2.13 Safety Requirements

5.2.3.2.13.1 Safety requirements shall apply as defined in [13], chapter 2.

5.2.4 Special Brake Inhibition Area – Trackside Orders

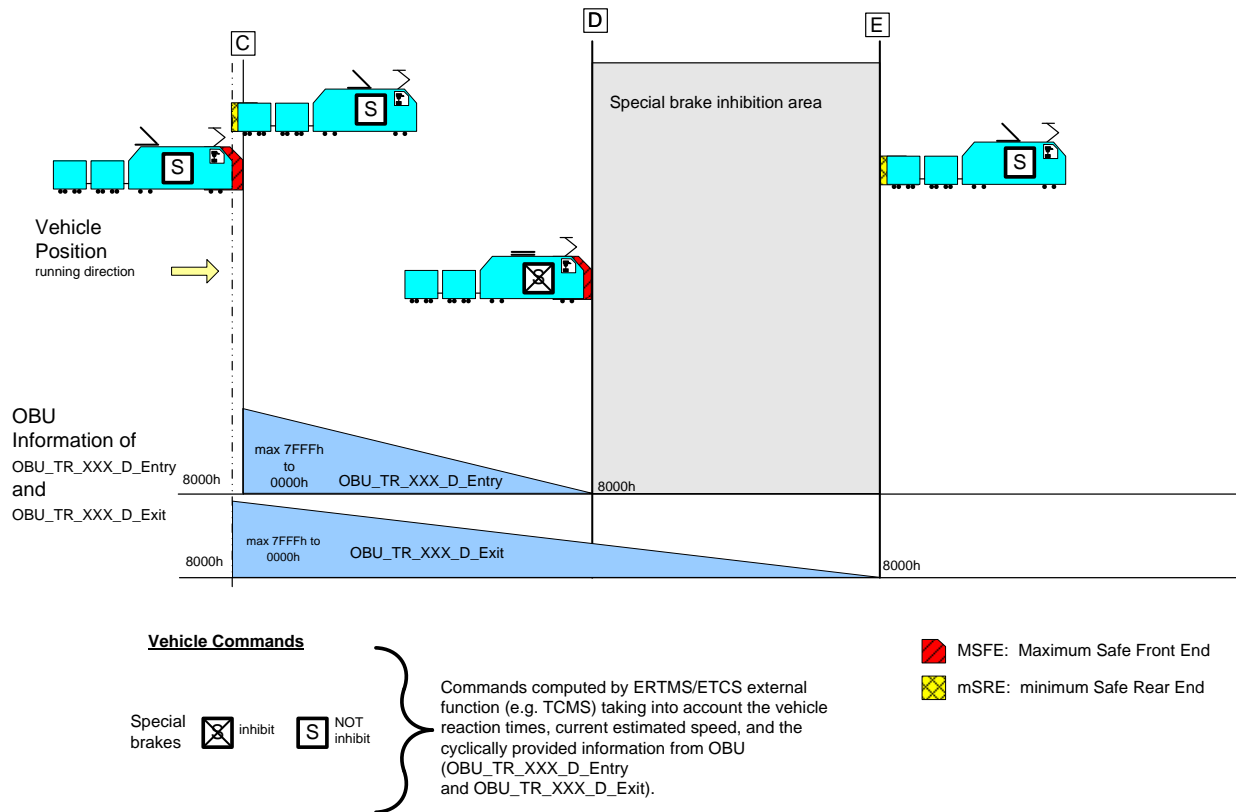

Figure 5-7 Passing a Special Brake Inhibition Area

- 5.2.4.1 This is a track condition to be handled although not included in chapter 5.3. Chapter 5.3.1 also applies for Special Brake Inhibition Area.
- 5.2.4.2 Note: In [1], 5.20.5 it is specified between which locations the ERTMS/ETCS on-board equipment shall provide the remaining distance to the start location point D (OBU_TR_XXX_D_Entry) and the remaining distance to the end location point E (OBU_TR_XXX_D_Exit) to the ERTMS/ETCS external function (e.g. TCMS).

5.2.4.3 Architecture

5.2.4.4 Only serial connection (bus) as defined in Chapter 4 is allowed.

5.2.4.5 Coding

Name	Size	Meaning
OBU_TR_RBI_D_Entry	16 bits	See Table 5-23 Resolution: 1 ≡ 1 m.
OBU_TR_RBI_D_Exit	16 bits	See Table 5-24 Resolution: 1 ≡ 1 m.

Table 5-11 Coding for Regenerative Brake Inhibit

Name	Size	Meaning
OBU_TR_MGI_D_Entry	16 bits	See Table 5-23 Resolution: 1 ≡ 1 m.
OBU_TR_MGI_D_Exit	16 bits	See Table 5-24 Resolution: 1 ≡ 1 m.

Table 5-12 Coding for Magnetic Shoe Brake Inhibit

Name	Size	Meaning
OBU_TR_ECS_D_Entry	16 bits	See Table 5-23 Resolution: 1 ≡ 1 m.
OBU_TR_ECS_D_Exit	16 bits	See Table 5-24 Resolution: 1 ≡ 1 m.

Table 5-13 Coding for Eddy Current Brake for Service Brake Inhibit

Name	Size	Meaning
OBU_TR_ECE_D_Entry	16 bits	See Table 5-23 Resolution: 1 ≡ 1 m.
OBU_TR_ECE_D_Exit	16 bits	See Table 5-24 Resolution: 1 ≡ 1 m.

Table 5-14 Coding for Eddy Current Brake for Emergency Brake Inhibit

5.2.4.6 Safety Requirements

5.2.4.6.1 Safety requirements shall apply as defined in [13], chapter 2.

5.2.5 Special Brake Inhibition Area – STM Orders

5.2.5.1 Architecture

5.2.5.1.1 Reference architecture as defined in Chapter 3 or serial connection (bus) as defined in Chapter 4 is allowed.

5.2.5.2 Coding

5.2.5.2.1 Regenerative brake inhibition command

© This document has been developed and released by UNISIG in collaboration with Faiveley Transport, Knorr-Bremse, TÜV, Voith Turbo and Vossloh

Name	Size	Meaning
OBU_TR_RBInhibit_Cmd O_RB_I	Binary output or (1 bit on bus)	0: Regenerative Brake is not to be inhibited 1: Regenerative Brake is to be inhibited

Table 5-15 Coding for Regenerative Brakes Inhibition command – STM Orders

5.2.5.2.2 Magnetic shoes brakes inhibition command

Name	Size	Meaning
OBU_TR_MGInhibit_Cmd O_MG_I	Binary output or (1 bit on bus)	0: Magnetic Shoe Brake is not to be inhibited 1: Magnetic Shoe Brake is to be inhibited

Table 5-16 Coding for Magnetic Shoe Brake Inhibition command – STM Orders

5.2.5.2.3 Eddy current brakes for service brake inhibition command

Name	Size	Meaning
OBU_TR_ECInhibit_Cmd O_ECS_I	Binary output or (1 bit on bus)	0: Eddy Current Brake for Service Brake is not to be inhibited 1: Eddy Current Brake for Service Brake is to be inhibited

Table 5-17 Coding for Eddy Current Brake for Service Brake Inhibition command – STM Orders

5.2.5.2.4 Eddy current brakes for emergency brake inhibition command

Name	Size	Meaning
OBU_TR_ECEInhibit_Cmd O_ECE_I	Binary output or (1 bit on bus)	0: Eddy Current Brake for Emergency Brake is not to be inhibited 1: Eddy Current Brake for Emergency Brake is to be inhibited

Table 5-18 Coding for Eddy Current Brake for Emergency Brake Inhibition command – STM Orders

5.2.5.3 Safety Requirements

5.2.5.3.1 Safety requirements shall apply as defined in [13], chapter 2.

5.2.6 Special Brake Status

5.2.6.1 General

5.2.6.1.1 The inhibition of a special brake results in a different model to be used by the ERTMS/ETCS on-board internally. Hence informing the ERTMS/ETCS on-board about the status of a specific special brake can be relevant to calculate the brake model that has to be used.

5.2.6.2 Architecture

5.2.6.2.1 Reference architecture as defined in Chapter 3 or serial connection (bus) as defined in Chapter 4 is allowed.

5.2.6.3 Coding

5.2.6.3.1 Electro Pneumatic Brake Status

T_EP_S_N/ EP_S	T_EP_S_I/ EP_S_Not	Meaning
0	0	Invalid
0	1	Brake not active, see definition in [6], §2.3.6.5.
1	0	Brake active, see definition in [6], §2.3.6.5.
1	1	Invalid

Table 5-19 Coding for Electro Pneumatic Brake Status

5.2.6.3.2 Eddy Current Brake Status

T_EC_S_N/ EC_S	T_EC_S_I/ EC_S_Not	Meaning
0	0	Invalid
0	1	Brake not active, see definition in [6], §2.3.6.5.
1	0	Brake active, see definition in [6], §2.3.6.5.
1	1	Invalid

Table 5-20 Coding for Eddy Current Brake Status

5.2.6.3.3 Regenerative Brake Status

T_RB_S_N/ RB_S	T_RB_S_I/ RB_S_Not	Meaning
0	0	Invalid
0	1	Brake not active, see definition in [6], §2.3.6.5.
1	0	Brake active, see definition in [6], §2.3.6.5.
1	1	Invalid

Table 5-21 Coding for Regenerative Brake Status

5.2.6.3.4 Magnetic Shoe Brake Status

T_MG_S_N/ MG_S	T_MG_S_I/ MG_S_Not	Meaning
0	0	Invalid
0	1	Brake not active, see definition in [6], §2.3.6.5.
1	0	Brake active, see definition in [6], §2.3.6.5.
1	1	Invalid

Table 5-22 Coding for Magnetic Shoe Brake Status

5.2.6.4 Safety Requirements

5.2.6.4.1 Safety requirements shall apply as defined in [13], chapter 2.

5.2.7 Additional Brake Status

- 5.2.7.1 Additional brakes shall be handled in the same manner like special brakes.
- 5.2.7.2 Currently no brakes which would qualify for “additional brakes” in the meaning of [1] are known.

5.3 Control of Train Functions

5.3.1 General

- 5.3.1.1 Note: The structure of the packets is defined in 4.3.6 to 4.3.13.
- 5.3.1.2 Note: A fixed data structure is used for track conditions with a specific structure and for which specific rules are foreseen in SS-040:
 - 5 track conditions Station Platform
 - 1 track condition Change of Traction System
 - 1 track condition Change of Allowed Current Consumption

Note: A generic data structure is used for transmitting track conditions that have the same data structure. Up to 20 track conditions can be transmitted by using the generic data structure. 20 has been selected in order to fulfill the rule of Subset-040, 4.3.2 I) for these track conditions:

- track condition Regenerative Brake Inhibition
 - track condition Magnetic Shoe Brake Inhibition
 - track condition Eddy Current Brake for SB Inhibition
 - track condition Eddy Current Brake for EB Inhibition
 - track condition Air Tightness Section
 - track condition Powerless Section with Pantograph to be Lowered
 - track condition Powerless Section with Main Power switch to be Switched Off
- 5.3.1.3 For the generic data structure part the track conditions shall be dynamically allocated to the generic packet data structure.
 - 5.3.1.4 Note: The final content of a packet is determined dynamically and depends on the track conditions information needed to be transmitted at the moment the message is created.

- 5.3.1.5 Note: The Track Conditions themselves are specified in [1].
- 5.3.1.6 Note: The specifications on how to perform the functions on the vehicle side are outside the scope of ERTMS/ETCS. Therefore, they are not part of this document and are not part of any other UNISIG document. This includes also a possibly needed merging of track condition of the same type in case the Rolling Stock (e.g. TCMS) receives several track conditions of the same type.
- 5.3.1.7 Due to trackside topology two track conditions of the same type can be encountered within a short period of time or short distance. It is the responsibility of the Rolling Stock (e.g. TCMS) to act in accordance with the characteristics of the vehicle. Example: The TCMS could decide to keep the flaps closed between two adjacent tunnels.
- 5.3.1.8 The ERTMS/ETCS on-board shall receive the information related to the Track Conditions from the trackside, process it and forward it to the ERTMS/ETCS external function (e.g. TCMS) via the TI. In this application data of Numerical signal type is used and therefore this information can be transmitted to the ERTMS/ETCS external function (e.g. TCMS) only via the serial interface. The information from ERTMS/ETCS on-board shall be used by the ERTMS/ETCS external function (e.g. TCMS) to perform all necessary actions at the right time (e.g. to change the traction system at the given location). This means that the ERTMS/ETCS external function (e.g. TCMS) has to take into account relevant delay times (e.g. for opening the main power switch). This offers the flexibility for the ERTMS/ETCS external function (e.g. TCMS) to take into account the physical positions of the actuators of the train with respect to the front end of the train (e.g. for opening the main power switch, the distance between the front end and the pantographs) when reacting on these outputs.
- 5.3.1.9 The generation of the information forwarded to the ERTMS/ETCS external function (e.g. TCMS) shall start as specified in chapter 5.20 of [1].
- 5.3.1.10 If the Track Condition data refer to a single location (reference point) and not to a track section, then only the start location has to be considered which in this case is equal to the exit point. Example: Change of allowed current consumption.
- 5.3.1.11 The cycle time for the Track Condition variables on the serial interface shall be according to Table 4-1.
- 5.3.1.12 Data type used for the remaining distances is an INTEGER16 (2's complement) with a resolution of 1 meter (see Table 5-23 and Table 5-24).

Value range	Meaning
8000h (special value)	No remaining distance to the start location of a track condition of the considered type or to the location of a change of traction system is provided to the train.
7FFFh (special value)	The value to be transmitted is higher than the highest value of the transmittable range. This special value is a flag indicating that the remaining distance value to be transmitted is higher than the max value of the range, i.e. > 32766 m.
8001h (special value)	The value to be transmitted is lower than the lowest value of the transmittable range. This special value is a flag indicating that the remaining distance value to be transmitted is lower than the min value of the range, i.e. < -32766 m.
7FFEh to 0000h (32766 m to 0 m) 8002h to FFFFh (-32766 m to -1 m)	This value represents the remaining distance to the start location of the track section.

Table 5-23 Coding of variables “OBU_TR_XXX_D_Entry” and “OBU_TR_XXX_D_Change”

Value range	Meaning
8000h (special value)	No remaining distance to end location of a track condition of the considered type is provided to the train. The initial state is required for the track condition. In case of ACC and CTS the current settings of the track condition shall be kept.
7FFFh (special value)	The value to be transmitted is higher than the highest value of the transmittable range. This special value is a flag indicating that the remaining distance value to be transmitted is higher than the max value of the range, i.e. > 32766 m.
8001h (special value)	The value to be transmitted is lower than the lowest value of the transmittable range. This special value is a flag indicating that the remaining distance value to be transmitted is lower than the min value of the range, i.e. < -32766 m.
7FFEh to 0000h (32766 m to 0 m) 8002h to FFFFh (-32766 m to -1 m)	This value represents the remaining distance to the end location of the track section.

Table 5-24 Coding of variables “OBU_TR_XXX_D_Exit”

- 5.3.1.13 Note: It is possible that the distance provided jumps (backwards or forwards) e.g. due to ETCS internal reset of odometry inaccuracy.
- 5.3.1.14 Note: The vehicle side has to consider the impact if a driver overrules commands for a track condition.
- 5.3.1.15 Note: For vehicles without serial interface a project specific adaptation is necessary which allows to command the ETCS Track Condition orders via hard-wired interface by computing all individual commands required to manage the Track Condition functions. Whether the function to transform the remaining distances into elementary commands is implemented inside the EVC or in any other device in the vehicle is a project specific matter.

5.3.2 Change of Traction System

- 5.3.2.1 Note: In [1], 5.20.6 it is specified between which locations the ERTMS/ETCS on-board equipment shall provide

- the remaining distance (OBU_TR_CTS_D_Change) to the location of change of traction system (point F),
- the new traction system (OBU_TR_CTS_NewId) and
- the new voltage (OBU_TR_CTS_NewVoltage)

to the ERTMS/ETCS external function (e.g. TCMS).

- 5.3.2.2 Architecture

- 5.3.2.2.1 Only serial connection (bus) as defined in Chapter 4 is allowed.

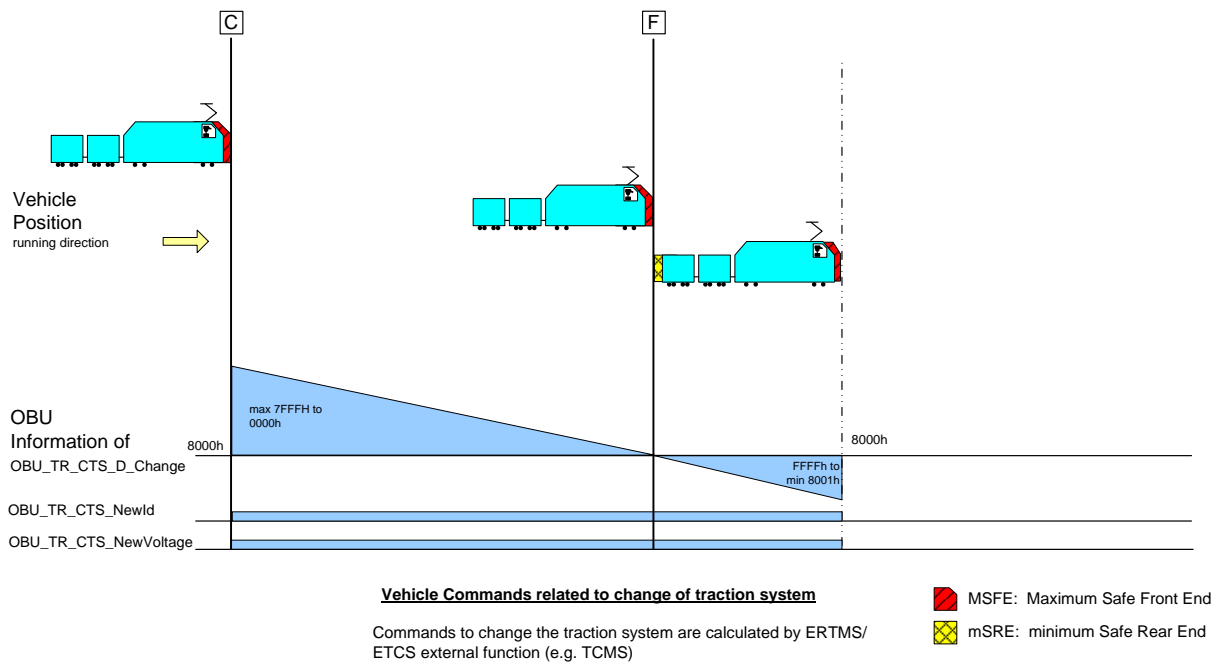

Figure 5-8 Changing the traction system

5.3.2.3 Coding

Name	Size	Meaning
OBU_TR_CTS_D_Change	16 bits	See Table 5-23, resolution: 1 ≙ 1 m.
OBU_TR_CTS_NewId	10 bits	The new traction system (NID_CTRACTION). For coding refer to NID_CTRACTION as defined in [1], 7.5.1.86.1. If M_VOLTAGE is 0 the value shall not be considered. Only 10 bits are used. The values from 1024 to 65535 are spare values.
OBU_TR_CTS_NewVoltage	4 bits	The new voltage (M_VOLTAGE). For coding refer to M_VOLTAGE as defined in [1], 7.5.1.78. Only 4 bits are used. The values from 16 to 255 are spare values.

Table 5-25 Coding for Change of Traction System

5.3.2.3.1 Note: In practice the change of traction system Track Condition may be used combined with another Track Condition e.g. a powerless section with pantograph to be lowered.

5.3.2.3.2 When receiving “change of traction system” information in which the variable OBU_TR_CTS_D_Change is set to the special value 8000h (see Table 5-23), the vehicle shall not consider the variables OBU_TR_CTS_NewId and OBU_TR_CTS_NewVoltage contained in this information.

5.3.2.4 Safety Requirements

5.3.2.4.1 Safety requirements shall apply as defined in [13], chapter 2.

5.3.3 Powerless Section with Pantograph to be Lowered – Trackside orders

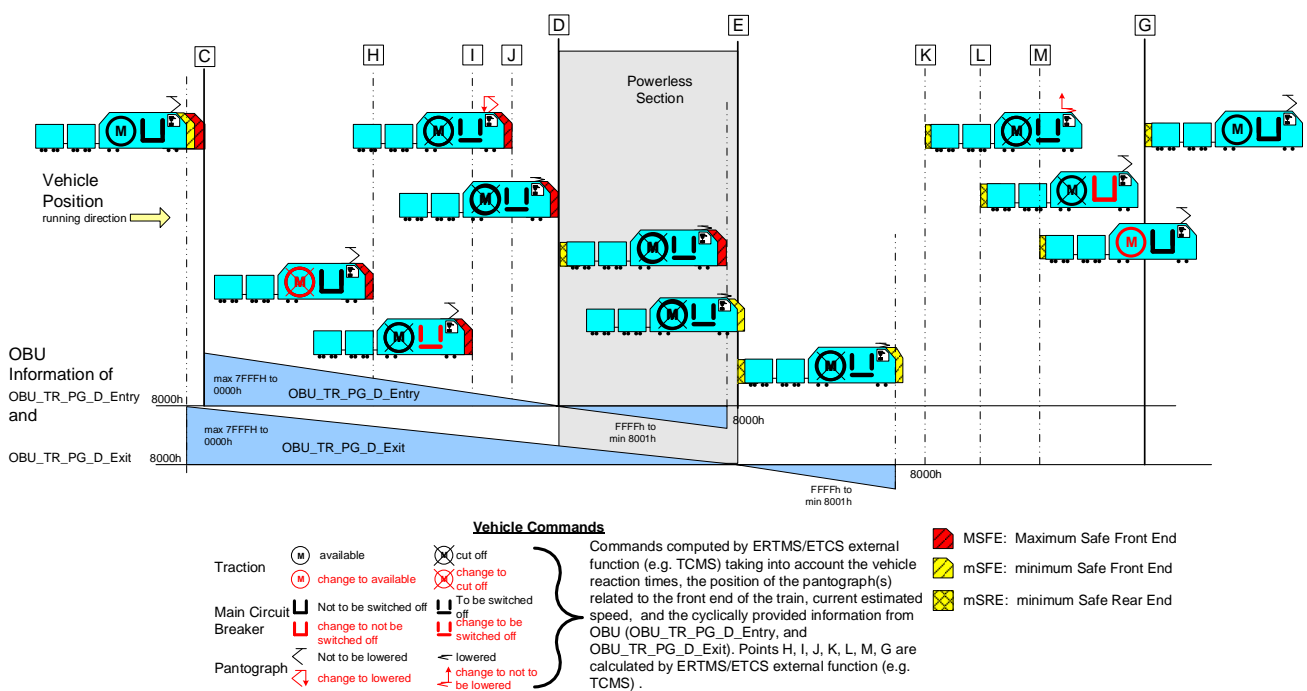

Figure 5-9 Passing a Powerless Section with Pantograph to be Lowered

5.3.3.1 Note: In [1], 5.20.2 it is specified between which locations the ERTMS/ETCS on-board equipment shall provide the remaining distance to the start location point D (OBU_TR_PG_D_Entry) and the remaining distance to the end location point E (OBU_TR_PG_D_Exit) to the ERTMS/ETCS external function (e.g. TCMS).

5.3.3.2 Note: The ERTMS/ETCS external function (e.g. TCMS) commands to cut off the traction when the max safe front end of the train reaches the point H.

5.3.3.3 Note: The ERTMS/ETCS external function (e.g. TCMS) commands to switch off the main circuit breaker when the max safe front end of the train reaches the point I.

- 5.3.3.4 Note: The ERTMS/ETCS external function (e.g. TCMS) commands to lower the pantograph when the max safe front end of the train reaches the point J.
- 5.3.3.5 Note: The ERTMS/ETCS external function (e.g. TCMS) commands the pantograph not to be lowered the when the min safe rear end of the train reaches the point K.
- 5.3.3.6 Note: The ERTMS/ETCS external function (e.g. TCMS) commands the main circuit not to be switched off when the min safe rear end of the train reaches the point L.
- 5.3.3.7 Note: The ERTMS/ETCS external function (e.g. TCMS) commands to change the traction to be available when the min safe rear end of the train reaches the point M.
- 5.3.3.8 Note: When the min safe rear end of the train reaches the point G the traction is available.
- 5.3.3.9 Note: The points H, I, J, K, L, M, and G are only for illustration for the sequence of the actions. The train could also control each pantograph separately and therefore react according to the location of the various pantographs, not according to the location of the train front/rear end as assumed in the figure.

5.3.3.10 Architecture

5.3.3.10.1 Only serial connection (bus) as defined in Chapter 4 is allowed.

5.3.3.11 Coding

Name	Size	Meaning
OBU_TR_PG_D_Entry	16 bits	See Table 5-23 Resolution: 1 ≡ 1 m.
OBU_TR_PG_D_Exit	16 bits	See Table 5-24 Resolution: 1 ≡ 1 m.

Table 5-26 Coding for Lower Pantograph Command

5.3.3.12 Safety Requirements

5.3.3.12.1 Safety requirements shall apply as defined in [13], chapter 2.

5.3.4 Pantograph – STM Orders

5.3.4.1 Architecture

5.3.4.1.1 Reference architecture as defined in Chapter 3 or serial interface is allowed.

5.3.4.2 Coding

Name	Size	Meaning
O_PG_C / OBU_TR_PG_Cmd	Binary output or (1 bit on bus)	0: Lower Pantograph 1: Raise pantograph

Table 5-27 Coding for Pantograph Command – STM Orders

5.3.4.3 Safety requirements

5.3.4.3.1 Safety requirements shall apply as defined in [13], chapter 2.

5.3.5 Air Tightness Area – Trackside orders

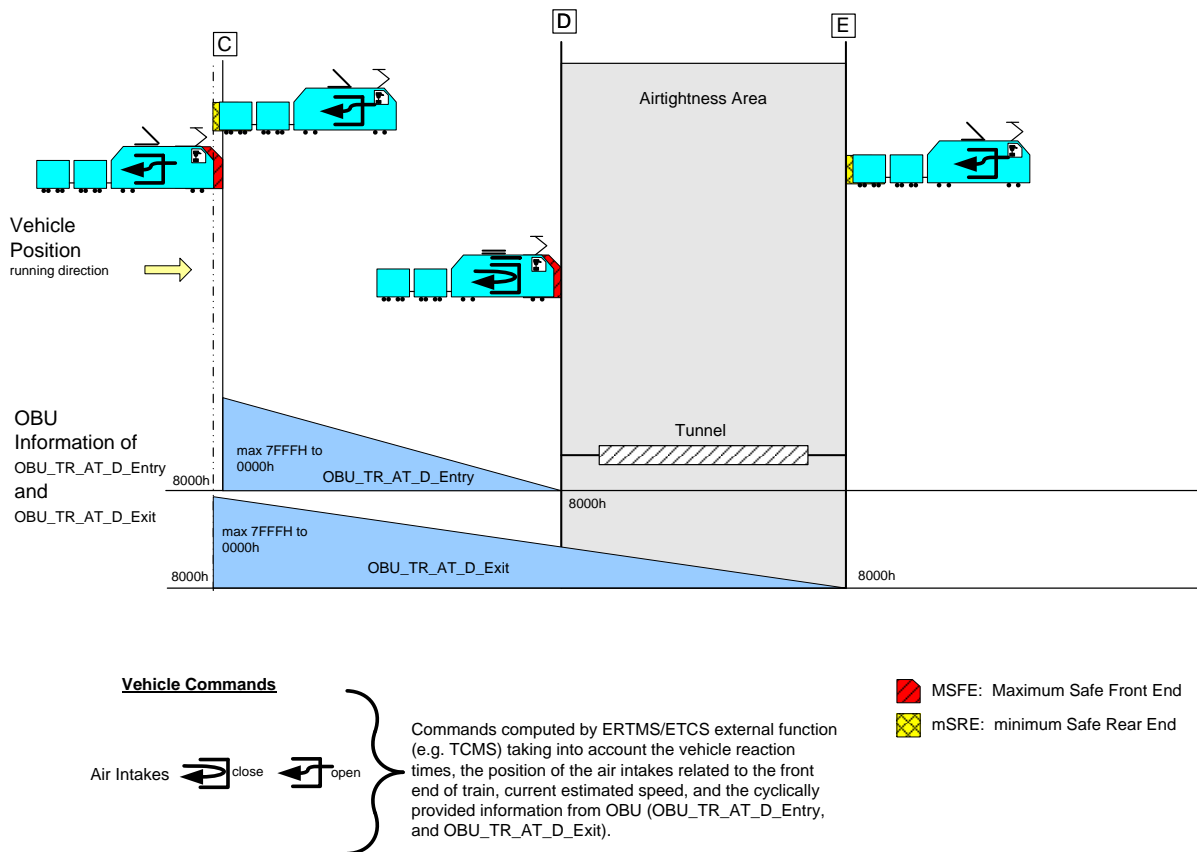

Figure 5-10 Passing an Air Tightness Area

5.3.5.1 Note: In [1], 5.20.4 it is specified between which locations the ERTMS/ETCS on-board equipment shall provide the remaining distance to the start location point D

(OBU_TR_AT_D_Entry) and the remaining distance to the end location point E (OBU_TR_AT_D_Exit) to the ERTMS/ETCS external function (e.g. TCMS).

5.3.5.2 Architecture

5.3.5.3 Only serial connection (bus) as defined in Chapter 4 is allowed.

5.3.5.4 Coding

Name	Size	Meaning
OBU_TR_AT_D_Entry	16 bits	See Table 5-23 Resolution: 1 \equiv 1 m.
OBU_TR_AT_D_Exit	16 bits	See Table 5-24 Resolution: 1 \equiv 1 m.

Table 5-28 Coding for Air Tightness Area Command

5.3.5.5 Safety Requirements

5.3.5.5.1 Safety requirements shall apply as defined in [13], chapter 2.

5.3.6 Air Tightness – STM Orders

5.3.6.1 Architecture

5.3.6.1.1 Reference architecture as defined in Chapter 3 or serial interface is allowed.

5.3.6.2 Coding

Name	Size	Meaning
OBU_TR_AT_Cmd O_AT_C	Binary output or (1 bits on bus)	0: Open air conditioning intake 1: Close air conditioning intake

Table 5-29 Coding for Air Tightness – STM Orders

5.3.6.3 Safety requirements

5.3.6.3.1 Safety requirements shall apply as defined in [13], chapter 2.

5.3.7 Station Platform

5.3.7.1 Note: In [1], 5.20.8 it is specified between which locations the ERTMS/ETCS on-board equipment shall provide

- the remaining distance to the start location point D ($OBU_TR_SP_D_Entry(K)$),
- the remaining distance to the end location point E ($OBU_TR_SP_D_Exit(K)$),
- the height of the platform above rail level ($OBU_TR_SP_Height(K)$),
- and the position of the platform ($OBU_TR_SP_Left(K)$ and $OBU_TR_SP_Right(K)$)

to the ERTMS/ETCS external function (e.g. TCMS).

5.3.7.2 Architecture

5.3.7.2.1 Only serial connection (bus) as defined in Chapter 4 is allowed.

5.3.7.3 Coding

Name	Size	Meaning
OBU_TR_SP_D_Entry(K)	16 bits	See Table 5-23 Resolution: 1 ≡ 1 m.
OBU_TR_SP_D_Exit(K)	16 bits	See Table 5-24 Resolution: 1 ≡ 1 m.
OBU_TR_SP_Height(K)_Bit0, OBU_TR_SP_Height(K)_Bit1, OBU_TR_SP_Height(K)_Bit2, OBU_TR_SP_Height(K)_Bit3	4 bits	The height of the platform above rail level (derived from M_PLATFORM [1], 7.5.1.75.5). Coding (Bit 3 / Bit 2 / Bit 1 / Bit 0): 0000: 200 mm 0001: 300-380 mm 0010: 550 mm 0011: 580 mm 0100: 680 mm 0101: 685 mm 0110: 730 mm 0111: 760 mm 1000: 840 mm 1001: 900 mm 1010: 915 mm 1011: 920 mm 1100: 960 mm 1101: 1100 mm 1110 – 1111: Spare
OBU_TR_SP_Right(K), OBU_TR_SP_Left(K)	2 bits	The position of the platform (derived from Q_PLATFORM [1], 7.5.1.126.2). Coding (OBU_TR_SP_Left(K) (Bit 1) / OBU_TR_SP_Right(K) (Bit 0)): 00: no platform (default value) 01: right 10: left 11: both sides

Table 5-30 Coding for Station Platform

5.3.7.3.1 Note:

K= number of stored information in the on-board (see [10], 4.3.2.1.1 t))

- .
- K= 0 no valid information
- K= 1 first station platform
- K= 2 second station platform
- ...
- K= 5 fifth station platform

5.3.7.3.2 When receiving “station platform” information in which, for a value of index K, both the variables OBU_TR_SP_D_Entry(K) and OBU_TR_SP_D_Exit(K) are set to the special value 8000h (see Table 5-23 and Table 5-24 respectively), the vehicle shall not consider the variables OBU_TR_SP_Height(K)_Bit0, OBU_TR_SP_Height(K)_Bit1, OBU_TR_SP_Height(K)_Bit2, OBU_TR_SP_Height(K)_Bit3, OBU_TR_SP_Left(K) and OBU_TR_SP_Right(K) contained in this information.

5.3.7.4 Safety Requirements

5.3.7.4.1 Safety requirements shall apply as defined in [13], chapter 2.

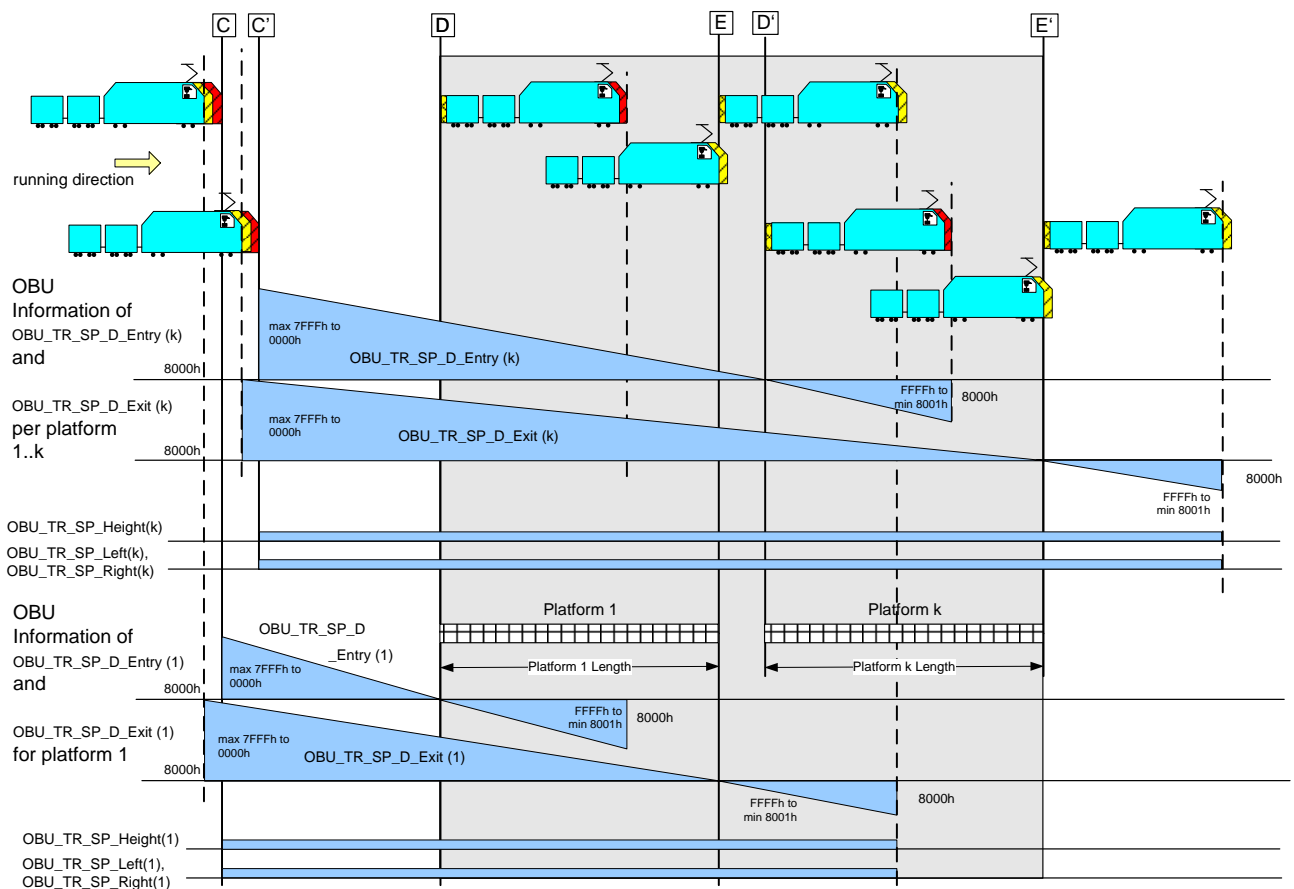

Vehicle Commands

Commands computed by ERTMS/ETCS external function (e.g. TCMS) taking into account the vehicle reaction times, the position of the platform(s) related to the length of train, current estimated speed, and the cyclically provided information from OBU (OBU_TR_SP_D_Entry(k), and OBU_TR_SP_D_Exit(k), OBU_TR_SP_Height(K), OBU_TR_SP_Left(K), OBU_TR_SP_Right(K)).



-  MSFE: Maximum Safe Front End
-  mSFE: minimum Safe Front End
-  mSRE: minimum Safe Rear End

Figure 5-11 Station Platform

5.3.8 Powerless Section with Main Power Switch to be Switched Off – Trackside Orders

5.3.8.1 Note: In [1], 5.20.3 it is specified between which locations the ERTMS/ETCS on-board equipment shall provide the remaining distance to the start location point D

(OBU_TR_MPS_D_Entry) and the remaining distance to the end location point E (OBU_TR_MPS_D_Exit) to the ERTMS/ETCS external function (e.g. TCMS).

- 5.3.8.2 Note: The ERTMS/ETCS external function (e.g. TCMS) commands to cut off the traction before the max safe front end of the train reaches the point H.
- 5.3.8.3 Note: The ERTMS/ETCS external function (e.g. TCMS) commands to switch off the main circuit breaker before the max safe front end of the train reaches the point I.
- 5.3.8.4 Note: The ERTMS/ETCS external function (e.g. TCMS) commands the main circuit not to be switched off when the min safe rear end of the train reaches the point L.
- 5.3.8.5 Note: The ERTMS/ETCS external function (e.g. TCMS) commands to change the traction to be available when the min safe rear end of the train reaches the point M.
- 5.3.8.6 Note: When the min safe rear end of the train reaches the point G the traction is available.
- 5.3.8.7 Note: The points H, I, L, M, and G are only for illustration for the sequence of the actions.
- 5.3.8.8 Architecture
- 5.3.8.8.1 Only serial connection (bus) as defined in Chapter 4 is allowed.

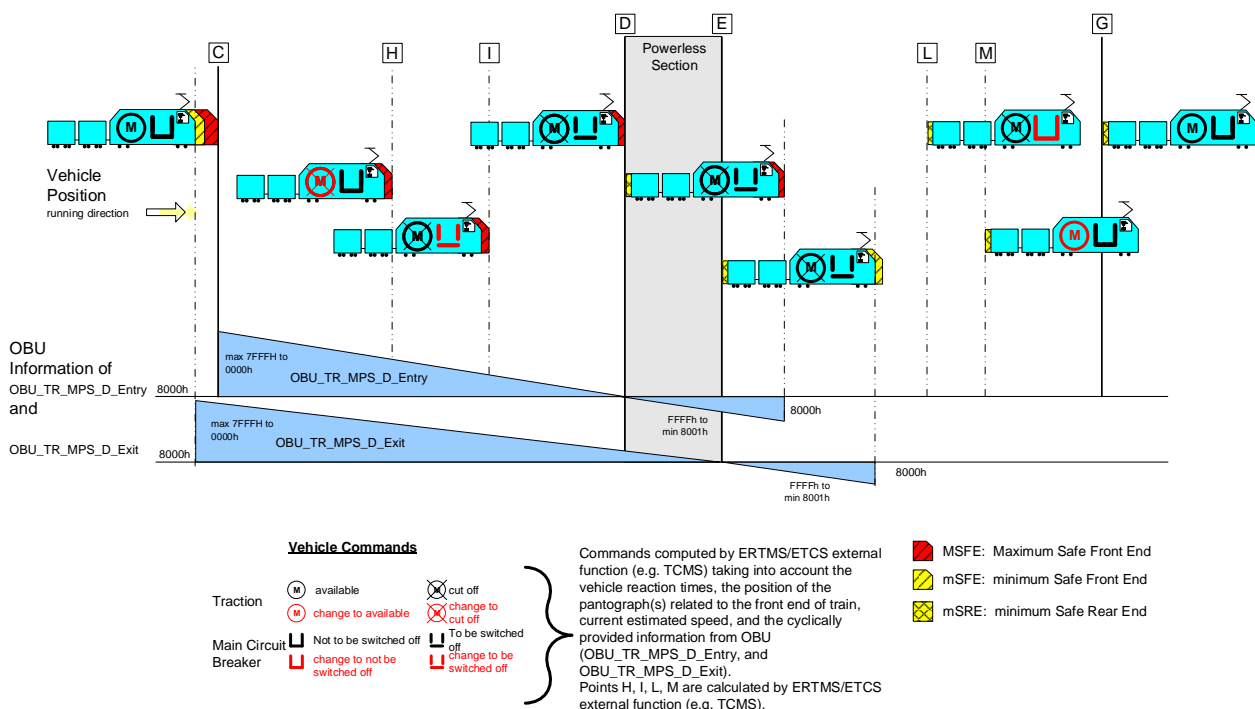

Figure 5-12 Passing a Powerless Section with Main Power Switch to be Switched Off

5.3.8.9 Coding

Name	Size	Meaning
OBU_TR_MPS_D_Entry	16 bits	See Table 5-23 Resolution: 1 \equiv 1 m.
OBU_TR_MPS_D_Exit	16 bits	See Table 5-24 Resolution: 1 \equiv 1 m.

Table 5-31 Coding for passing a Powerless Section with Main Power Switch to be Switched Off

5.3.8.10 Safety Requirements

5.3.8.11 Safety requirements shall apply as defined in [13], chapter 2.

5.3.9 Main Power Switch – STM Orders

5.3.9.1 Architecture

5.3.9.1.1 Reference architecture as defined in Chapter 3 or serial interface is allowed.

5.3.9.2 Coding

Name	Size	Meaning
O_MPS_C / OBU_TR_MPS_Cmd	Binary output or (1 bit on bus)	0: Main Power Switch to be switched off 1: Main Power Switch NOT to be switched off

Table 5-32 Coding for Main Power Switch – STM Orders

5.3.9.3 Safety requirements

5.3.9.3.1 Safety requirements shall apply as defined in [13], chapter 2.

5.3.10 Change of Allowed Current Consumption

5.3.10.1 Note: In [1], 5.20.7 it is specified between which locations the ERTMS/ETCS on-board equipment shall provide the remaining distance (OBU_TR_ACC_D_Change) to the location of change of allowed current consumption (point F) and the new current limit (OBU_TR_ACC_Limit) to the ERTMS/ETCS external function (e.g. TCMS).

5.3.10.2 Architecture

5.3.10.2.1 Only serial connection (bus) as defined in Chapter 4 is allowed.

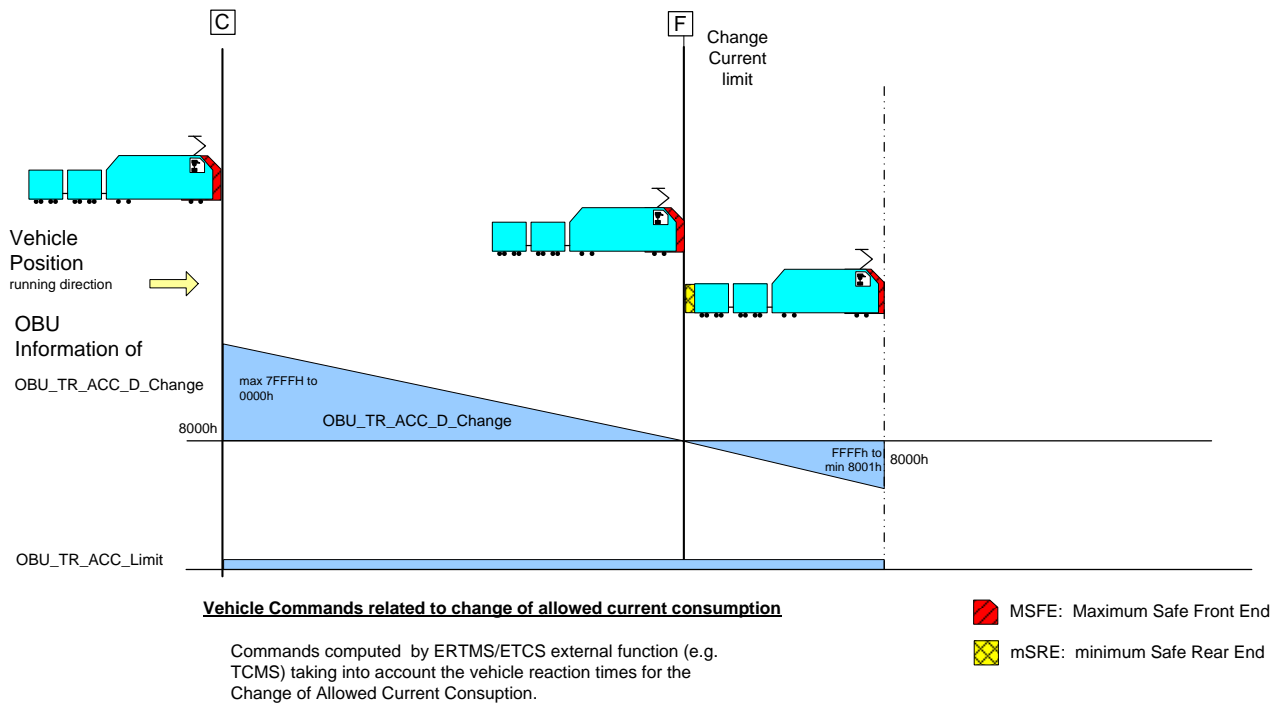

Figure 5-13 Change of Allowed Current Consumption

5.3.10.3 Coding

Name	Size	Meaning
OBU_TR_ACC_D_Change	16 bits	See Table 5-23, resolution: 1 ≙ 1 m.
OBU_TR_ACC_Limit	10 bits	New current limit (M_CURRENT). (For coding, Min value and Max value refer to M_CURRENT as defined in [1], 7.5.1.62.1). Only 10 bits are used. The values from 1024 to 65535 are spare values.

Table 5-33 Coding for Change of Allowed Current Consumption

5.3.10.3.1 When receiving “change of allowed current consumption” information in which the variable OBU_TR_ACC_D_Change is set to the special value 8000h (see Table 5-23), the vehicle shall not consider the variable OBU_TR_ACC_Limit contained in this information.

5.3.10.4 Safety Requirements

5.3.10.5 Safety requirements shall apply as defined in [13], chapter 2.

5.3.11 Engine Orientation in Supervised Manoeuvre

5.3.11.1 General

5.3.11.1.1 This output is generated by the ERTMS/ETCS on-board in Supervised Manoeuvre mode to indicate to the train how to interpret the relevant track condition outputs, see illustration in Figure 5-14.

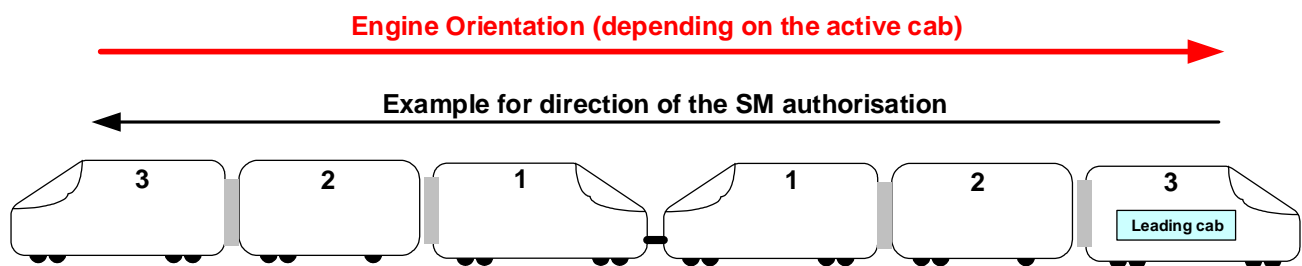

Figure 5-14 Illustration of the term Engine Orientation

5.3.11.2 Architecture

5.3.11.2.1 Reference architecture as defined in Chapter 3 or serial connection (bus) as defined in Chapter 4 is allowed.

5.3.11.3 Coding

O_EO_S/ OBU_TR_EngOrientSM	Meaning
0	The engine orientation is the same as the one of the SM authorisation
1	The engine orientation is opposite to the one of the SM authorisation

Table 5-34 Coding for Engine Orientation in Supervised Manoeuvre

5.3.11.4 Safety Requirements

5.3.11.4.1 Safety requirements shall apply as defined in [13], chapter 2.

5.3.12 Traction Cut-Off

5.3.12.1 General

5.3.12.1.1 The following signal is defined as the traction cut off as soon as the train passes the warning limit of the braking curve model as defined in [1] or as a consequence of an STM command (see Table 1-2).

5.3.12.1.2 Note: With traction cut-off the driving force is cut. Electrical traction could still be used for braking, depending on the specific vehicle implementation.

5.3.12.1.2.1 The Traction Cut-Off command is used as defined in [1] 3.13.9.3.2.3 a) and 3.13.2.2.8.1.

5.3.12.1.2.2 Architecture

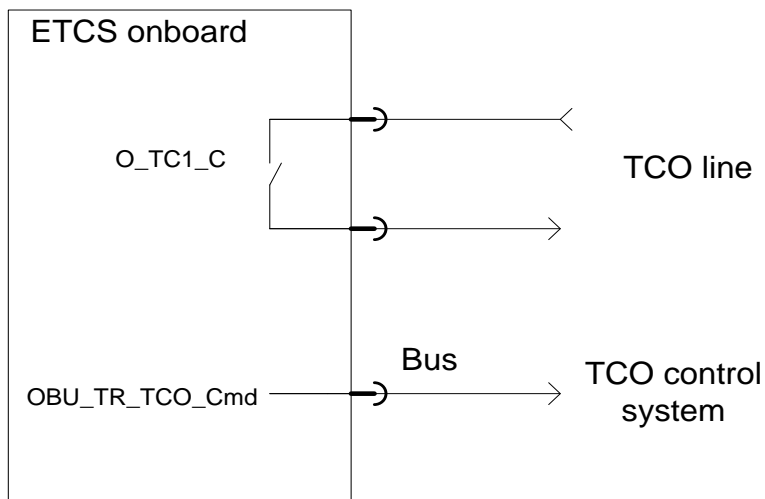

Figure 5-15 TCO function: 1 TCO line and a serial interface

5.3.12.2 Coding

O_TC1_C	OBU_TR_TCO_Cmd	Meaning
1	1	Traction cut-off not commanded
0	1	Traction cut-off commanded.
1	0	Traction cut-off commanded.
0	0	Traction cut-off commanded.

Table 5-35 Coding for Traction Cut Off

5.3.12.3 Safety Requirements

5.3.12.3.1 Safety requirements shall apply as defined in [13], chapter 2.

5.4 Signals for Train Status Information

5.4.1 Cab Status

5.4.1.1 Architecture

5.4.1.1.1 Reference architecture as defined in Chapter 3 or serial connection (bus) as defined in Chapter 4 is allowed.

5.4.1.2 Coding

T_CS_A / TR_OBU_CabStatusA	T_CS_B / TR_OBU_CabStatusB	Meaning
0	0	no cab active
1	0	Cab A active
0	1	Cab B active
1	1	Invalid

Table 5-36 Coding for Cab Status

5.4.1.2.1 In case the ETCS on-board unit receives the status of two cabs (Cab A and Cab B), the status of Cab A shall be connected to the “Cab Status A” input and the status of Cab B shall be connected to the “Cab Status B” input.

5.4.1.2.2 Note: In case the train is fitted with two ETCS on-board units (one on each end of the train), it is sufficient to provide only the cab status signal related to the local cab.

5.4.1.3 Safety Requirements

5.4.1.3.1 Safety requirements shall apply as defined in [13], chapter 2.

5.4.2 Direction Controller

5.4.2.1 Architecture

5.4.2.1.1 Reference architecture as defined in Chapter 3 or serial connection (bus) as defined in Chapter 4 is allowed.

5.4.2.2 Coding

T_FW_S / TR_OBU_DirectionFW	T_BW_S / TR_OBU_DirectionBW	Meaning
0	0	Neutral (no direction selected)
1	0	Forward (relative to active cab)
0	1	Backward (relative to active cab)
1	1	Invalid

Table 5-37 Coding for Direction Controller

5.4.2.3 Safety requirements

5.4.2.3.1 Safety requirements shall apply as defined in [13], chapter 2.

5.4.3 Train Integrity

5.4.3.1 Architecture

5.4.3.1.1 Reference architecture as defined in Chapter 3 or serial connection (bus) as defined in Chapter 4 is allowed.

5.4.3.1.2 Note: The train length as acquired as train data from an external source (see section 5.5.4.3) may be also relevant for train integrity.

5.4.3.2 Coding

T_TRI_S1_N/ TR_OBU_ TrainIntegrity_ S1	T_TRI_S1_I/ TR_OBU_ TrainIntegrity_ S1_Not	T_TRI_S2_N/ TR_OBU_ TrainIntegrity_ S2	T_TRI_S2_I/ TR_OBU_ TrainIntegrity_ S2_Not	Meaning
0	0	0	0	Invalid
0	0	0	1	Invalid
0	0	1	0	Invalid
0	0	1	1	Invalid
0	1	0	0	Invalid
0	1	0	1	Train Integrity Lost
0	1	1	0	Train integrity status unknown
0	1	1	1	Invalid
1	0	0	0	Invalid
1	0	0	1	Invalid
1	0	1	0	Train integrity confirmed
1	0	1	1	Invalid
1	1	0	0	Invalid
1	1	0	1	Invalid
1	1	1	0	Invalid
1	1	1	1	Invalid

Table 5-38 Coding for Train Integrity

5.4.3.3 Safety Requirements

5.4.3.3.1 Safety requirements shall apply as defined in [13], chapter 2.

5.4.4 Traction Status

5.4.4.1 Architecture

5.4.4.1.1 Reference architecture as defined in Chapter 3 or serial connection (bus) as defined in Chapter 4 is allowed.

5.4.4.2 Coding

T_TR_S / TR_OBU_Traction_Status	Meaning
0	Traction is Off
1	Traction is On

Table 5-39 Coding for Traction Status (only for STM)

5.4.4.2.1 Note: “Traction off” refers to traction zero or negative (electro-dynamic brake) whereas “traction on” refers when traction is positive.

5.4.4.3 Safety Requirements

5.4.4.3.1 Safety requirements shall apply as defined in [13], chapter 2.

5.4.5 Set Speed

5.4.5.1 Architecture

5.4.5.1.1 Only serial connection (bus) as defined in Chapter 4 is allowed.

5.4.5.2 Coding

Name	Size	Meaning	
TR_OBU_SetSpeedValue	16 bits	0 ... 600	Set speed in steps of 1 km/h up to 600 km/h
		601... 65535	Spare values

Table 5-40 Coding for Set Speed value

Name	Size	Meaning
TR_OBU_SetSpeedDisplay	Binary output (1 bits on bus)	1: set speed to be displayed 0: set speed not to be displayed

Table 5-41 Coding for Set Speed display

5.4.5.3 Safety Requirements

5.4.5.3.1 Safety requirements shall apply as defined in [13], chapter 2.



5.5 Train Data

5.5.1 General

5.5.1.1.1 This section specifies two ways of providing train data to ETCS on-board via the Train Interface:

- The train data themselves.
- The train data are derived from type of train configuration information. The identifier is used by the ETCS on-board to select the appropriate train data set among the pre-configured ones.

5.5.1.1.2 The following sections specify which of these two ways applies for each train data element.

5.5.1.1.3 A “train data set” represents a set of train data consisting of all the data that are specified in 6.1.1.1 item 6.

5.5.1.1.4 The train data can be derived from type of train configuration input. This input is specified in 5.5.1.2. Which train data shall be derived from this input is configured on-board.

5.5.1.1.5 When the train does not provide a train data element the corresponding validity bit is set to 0, see 4.3.1.3.1. This might be a degraded situation, which has to be handled project specific (e.g. by using existing pre-defined values or train data have to be entered manually).

5.5.1.2 Type of Train Configuration

5.5.1.2.1 The type of train configuration input can be used to deduce the values of the train data (see list of the data in section 6.1.1.1, Table 6-1, no. 6).

5.5.1.2.2 The number of values of the “type of train configuration” to use and their meaning is configured on-board.

5.5.1.2.3 If no type of train configuration value is provided the validity bit shall be set to FALSE.

5.5.1.2.4 Architecture

5.5.1.2.4.1 Only serial connection (bus) as defined in Chapter 4 is allowed.

5.5.1.2.5 Coding

Name	Size	Meaning	
TR_OBU_TypeTrainConfiguration	5 bits	0 ... 31	A train data set is selected among pre-configured train data sets input.

Table 5-42 Coding of variable Type of Train Configuration

5.5.1.3 For ERTMS/ETCS on-board equipment principle regarding the consideration of the train data inputs received from the train interface see [6] §2.6.4.

5.5.2 Type of Train Data Entry

5.5.2.1 General

5.5.2.1.1 This input indicates the type of train data entry configuration to be applied (see clause 11.3.9.6 of [2] (DMI spec)).

5.5.2.2 Architecture

5.5.2.2.1 Reference architecture as defined in Chapter 3 or serial connection (bus) as defined in Chapter 4 is allowed.

5.5.2.3 Coding

T_TT_S1 / TR_OBU_TypeTrainData_S1	T_TT_S2 / TR_OBU_TypeTrainData_S2	Meaning
0	0	Invalid
1	0	Fixed
0	1	Flexible
1	1	Switchable

Table 5-43 Coding for Type of Train Data Entry

5.5.2.4 Safety Requirements

5.5.2.4.1 Safety requirements shall apply as defined in [13], chapter 2.

5.5.3 Overall Consist Length Information

5.5.3.1.1 The train interface allows the ETCS on-board to determine the overall consist length values as follows:

- By selecting/calculating the adequate overall consist length value based on the “type of train configuration” input.
- By receiving the values of the overall consist length from the train interface.

5.5.3.2 Architecture

5.5.3.2.1 For the six overall consist lengths values the serial connection (bus) as defined in Chapter 4 is allowed.

Name	Size	Meaning
TR_OBU_L_ CONSISTFRONTCABAMAX	16 bits	The max consist length on the side of the engine corresponding to Cab A, counted from the end of the engine corresponding to the orientation of this cab A, and considering the coupling play and/or any other uncertainties in the consist length information, transmitted to the ERTMS/ETCS on-board in [m]. For the coding refer to the definition in [1], 7.5.1.42.1. Only 12 bits are used. The values from 4096 to 65535 are spare values.
TR_OBU_L_ CONSISTFRONTCABAMIN	16 bits	The min consist length on the side of the engine corresponding to Cab A, counted from the end of the engine corresponding to the orientation of this cab A, and considering the coupling play and/or any other uncertainties in the consist length information, transmitted to the ERTMS/ETCS on-board in [m]. For the coding refer to the definition in [1], 7.5.1.42.2. Only 12 bits are used. The values from 4096 to 65535 are spare values.

<p>TR_OBU_L_ CONSISTFRONTENGINENOM</p>	<p>16 bits</p>	<p>The nominal consist length on the side of the engine corresponding to Cab A without any coupling play, counted from the end of the engine corresponding to the orientation of this cab A, transmitted to the ERTMS/ETCS on-board in [m].</p> <p>For the coding refer to the definition in [1], 7.5.1.42.3.</p> <p>Only 12 bits are used. The values from 4096 to 65535 are spare values.</p>
<p>TR_OBU_L_ CONSISTREAR CABAMAX</p>	<p>16 bits</p>	<p>The max consist length on the side of the engine opposite to Cab A, counted from the end of the engine corresponding to the orientation of this cab A, and considering the coupling play and/or any other uncertainties in the consist length information, transmitted to the ERTMS/ETCS on-board in [m].</p> <p>For the coding refer to the definition in [1], 7.5.1.42.4.</p> <p>Only 12 bits are used. The values from 4096 to 65535 are spare values.</p>
<p>TR_OBU_L_ CONSISTREAR CABAMIN</p>	<p>16 bits</p>	<p>The min consist length on the side of the engine opposite to Cab A, counted from the end of the engine corresponding to the orientation of this cab A, and considering the coupling play and/or any other uncertainties in the consist length information, transmitted to the ERTMS/ETCS on-board in [m].</p> <p>For the coding refer to the definition in [1], 7.5.1.42.5.</p> <p>Only 12 bits are used. The values from 4096 to 65535 are spare values.</p>

TR_OBU_L_ CONSISTREARCANOM	16 bits	<p>The nominal consist length on the side of the engine opposite to Cab A without any coupling play, counted from the end of the engine corresponding to the orientation of this cab A, transmitted to the ERTMS/ETCS on-board in [m].</p> <p>For the coding refer to the definition in [1], 7.5.1.42.6.</p> <p>Only 12 bits are used. The values from 4096 to 65535 are spare values.</p>
-------------------------------	---------	--

Table 5-44 Coding for Overall Consist Length

5.5.3.3 Safety Requirements

5.5.3.3.1 Safety requirements shall apply as defined in [13], chapter 2.

5.5.4 Other Train Data Information

5.5.4.1 General

5.5.4.1.1 The following solutions require a serial bus system connection between ERTMS/ETCS on-board equipment and train control system. Only some train data can be implemented on hard-wired interface. Such an implementation is an option (see Table 2-1 with footnote 1).

5.5.4.1.2 Note: The procedure “Changing Train Data from sources different from the driver” only starts if a change of input information, which affects train data, is detected on an ERTMS/ETCS on-board external interface (see [1], 5.17.2.2, S0). Therefore, the train data validated by the driver are not changed as long as inputs on the Train Interface, which affects these train data, do not change.

5.5.4.1.3 Note: Axle Number is a purely static data element and is set only by configuration in the ETCS on-board. These data are not part of train data by external sources in Subset 119.

5.5.4.1.4 Note: Also the List of National Systems Available On-board is out of scope of the standardized train interface. In [6] National System Isolation is related only to STMs.

5.5.4.1.5 Note: “Other international train category” is not transferred via Train Interface since “brake position” input is transferred.

5.5.4.2 Train Category Cant Deficiency

5.5.4.2.1 The train interface allows the ETCS on-board to determine the cant deficiency value as follows:

- By selecting/calculating the adequate cant deficiency value based on the “type of train configuration” input.
- By receiving the value of the cant deficiency from the train interface.

5.5.4.2.2 Architecture for transferring the variable via TI

5.5.4.2.2.1 Only serial connection (bus) as defined in Chapter 4 is allowed.

5.5.4.2.3 Coding

5.5.4.2.3.1 It is a 4 bit variable with a specific meaning as defined in [1], 7.5.1.82.2.

5.5.4.2.4 Safety Requirements

5.5.4.2.4.1 Safety requirements shall apply as defined in [13], chapter 2.

5.5.4.3 Train Length

5.5.4.3.1 The train interface allows the ETCS on-board to determine the train length value as follows:

- By selecting/calculating the adequate train length value based on the “type of train configuration” input.
- By receiving the value of the train length from the train interface.

5.5.4.3.2 Architecture for transferring the variable via TI

5.5.4.3.2.1 Only serial connection (bus) as defined in Chapter 4 is allowed.

5.5.4.3.3 Coding

5.5.4.3.3.1 The train length is transmitted to the ERTMS/ETCS on-board as 12 bit variable in [m] according to [1], 7.5.1.56.

5.5.4.3.4 Safety Requirements

5.5.4.3.4.1 Safety requirements shall apply as defined in [13], chapter 2.

5.5.4.4 Traction / Brake Parameters

5.5.4.4.1 General

- 5.5.4.4.1.1 The traction / brake parameters consist of the time for traction cut-off ($T_{\text{traction_cut_off}}$) (traction model) and several brake models.
- 5.5.4.4.1.2 A brake model parameter set corresponding to each different train configuration or different actual states of the brake system (e. g. brakes defective) shall be predefined (by the train integrator) and stored in the ERTMS/ETCS on-board.
- 5.5.4.4.1.3 Note: Correction factors for the emergency deceleration are not transmitted via TI. This data is pre-configured in the ETCS on-board (linked to each EB speed dependent deceleration model, see [1] 3.13.2.2.9.1.2).
- 5.5.4.4.1.4 Note: Correction factor for gradient on normal service deceleration is not transmitted via TI. This data is pre-configured in the ETCS on-board.
- 5.5.4.4.1.5 Note: Taking into account the last two clauses the following parameters have to be considered as traction / brake parameters from the parameters listed in [1], 3.18.3.2 :
- Traction model
 - Brake build up time model and speed dependent deceleration model
 - Brake percentage
 - Brake position
 - Nominal rotating mass
- 5.5.4.4.2 Traction Model
- 5.5.4.4.2.1 The train interface allows the ETCS on-board to determine the traction model value (value of time delay $T_{\text{traction_cut_off}}$ as per [1] 3.13.2.2.2.1) as follows:
- By selecting/calculating the adequate traction model value based on the “type of train configuration” input.
- 5.5.4.4.2.2 Note: the traction model value can depend on the train length value and the selection of the adequate traction model value can therefore be based on the “type of train configuration” input.
- 5.5.4.4.3 Brake build up time model and speed dependent deceleration model:
- 5.5.4.4.3.1 The train interface allows the ETCS on-board to determine the brake build up time model values ($T_{\text{brake_emergency}}$ values and $T_{\text{brake_service}}$ values, see [1] 3.13.2.2.3.2) and speed dependent deceleration model values ($A_{\text{brake_emergency}}(V)$ and $A_{\text{brake_service}}(V)$, see [1] 3.13.2.2.3.1) as follows:

- By selecting the train data set including the adequate brake build up time model values and the speed dependent deceleration model values based on the “type of train configuration” input plus the status of special brakes (see [1] 3.13.2.2.6.2).
- By calculating the adequate brake build up time value in a project specific way using the conversion models based on ‘brake position’ and ‘train length’ and by calculating the adequate speed dependent deceleration model values by applying the conversion model to the brake percentage value.

5.5.4.4.3.2 The speed dependent deceleration models related to the normal service brake are pre-configured in the ETCS on-board and the selection of the appropriate model is based on the service brake deceleration at zero speed, $A_{\text{brake_service}}(V=0)$, deduced from the full service brake model and the brake position (see 5.5.4.4.5).

5.5.4.4.4 Brake percentage

5.5.4.4.4.1 The train interface allows the ETCS on-board to determine the brake percentage value as follows:

- By selecting/calculating the adequate brake percentage value based on the “type of train configuration” input.
- By receiving the value of the brake percentage from the train interface based on a “brake percentage” input, which is acquired by other means than ETCS train data entry.

5.5.4.4.4.2 Architecture for transferring the variable via TI

5.5.4.4.4.2.1 Only serial connection (bus) as defined in Chapter 4 is allowed.

5.5.4.4.4.3 Coding

Name	Size	Meaning	
TR_OBU_BrakePercentage	8 bits	0 ... 9	Spare values
		10 ... 250	See [1], A.3.11, resolution: 1 %
		251 ... 255	Spare values

Table 5-45 Coding of variable Brake Percentage

5.5.4.4.5 Brake position

5.5.4.4.5.1 The train interface allows the ETCS on-board to determine the brake position value as follows:

- By selecting/calculating the adequate brake position value based on the “type of train configuration” input.
- By receiving the value of the brake position from the train interface which is read e.g. from a switch installed at vehicle level.

5.5.4.4.5.2 Architecture for transferring the variable via TI

5.5.4.4.5.2.1 Reference architecture as defined in Chapter 3 or serial connection (bus) as defined in Chapter 4 is allowed.

5.5.4.4.5.3 Coding

T_BP_S1_N / TR_OBU_ BrakePosition1	T_BP_S1_I / TR_OBU_Brake Position1_Not	T_BP_S2_N / TR_OBU_ BrakePosition2	T_BP_S2_I / TR_OBU_Brake Position2_Not	Meaning (see [1], 3.13.2.2.4.1)
0	0	0	0	Invalid
0	0	0	1	Invalid
0	0	1	0	Invalid
0	0	1	1	Invalid
0	1	0	0	Invalid
0	1	0	1	Invalid
0	1	1	0	Passenger train in P
0	1	1	1	Invalid
1	0	0	0	Invalid
1	0	0	1	Freight train in P
1	0	1	0	Freight train in G
1	0	1	1	Invalid
1	1	0	0	Invalid
1	1	0	1	Invalid
1	1	1	0	Invalid
1	1	1	1	Invalid

Table 5-46 Coding for Brake Position

5.5.4.4.6 Nominal rotating mass

5.5.4.4.6.1 The train interface allows the ETCS on-board to determine the nominal rotating mass value as follows:

- By selecting/calculating the adequate nominal rotating mass value based on the “type of train configuration” input.

5.5.4.4.7 Safety Requirements

5.5.4.4.7.1 Safety requirements shall apply as defined in [13], chapter 2.

5.5.4.5 Maximum Train Speed

5.5.4.5.1 The train interface allows the ETCS on-board to determine the maximum train speed value as follows:

- By selecting/calculating the adequate maximum train speed value based on the “type of train configuration” input.

5.5.4.5.2 The maximum train speed is a 7 bit variable with values in steps of 5 km/h according to [1], 7.5.1.160.

5.5.4.5.3 Safety Requirements

5.5.4.5.3.1 Safety requirements shall apply as defined in [13], chapter 2.

5.5.4.6 Loading Gauge

5.5.4.6.1 The train interface allows the ETCS on-board to determine the loading gauge value as follows:

- By selecting/calculating the adequate loading gauge value based on the “type of train configuration” input.
- By receiving the value of the loading gauge from the train interface.

5.5.4.6.2 Architecture for transferring the variable via TI

5.5.4.6.2.1 Only serial connection (bus) as defined in Chapter 4 is allowed

5.5.4.6.3 Coding

5.5.4.6.3.1 The loading gauge is transmitted as 8 bit variable with values according to [1], 7.5.1.68.

5.5.4.6.4 Safety Requirements

5.5.4.6.4.1 Safety requirements shall apply as defined in [13], chapter 2.

5.5.4.7 Axle Load Category

5.5.4.7.1 The train interface allows the ETCS on-board to determine the axle load category value as follows:

- By selecting/calculating the adequate axle load category value based on the “type of train configuration” input.
- By receiving the value of the axle load category from the train interface.

5.5.4.7.2 Architecture for transferring the variable via TI

5.5.4.7.2.1 Only serial connection (bus) as defined in Chapter 4 is allowed.

5.5.4.7.3 Coding

5.5.4.7.3.1 The axle load category is transmitted as 7 bit variable with values according to [1], 7.5.1.62.

5.5.4.7.4 Safety Requirements

5.5.4.7.4.1 Safety requirements shall apply as defined in [13], chapter 2.

5.5.4.8 Traction system(s) accepted by the engine

5.5.4.8.1 The train interface allows the ETCS on-board to determine the traction system(s) accepted by the engine value as follows:

- By selecting/calculating the adequate traction system(s) accepted by the engine values based on the “type of train configuration” input.
- By receiving the list of available traction systems accepted by the engine from the train interface.

5.5.4.8.2 Architecture for transferring the variable via TI

5.5.4.8.2.1 Only serial connection (bus) as defined in Chapter 4 is allowed.

5.5.4.8.3 Coding

Name	Size	Meaning	
TR_OBU_SupTractionSys	32 bits	0	Spare value
		1 ... 31	A list of available traction systems is provided. This list is transmitted as a binary mask, indicating which traction systems configured in the on-board shall be considered as available (1 is available, 0 is not available). The assignment shall be defined according to chapter 6 "Configuration Management".

Table 5-47 Coding of Traction System(s) Accepted by the Engine

5.5.4.8.3.1 The configured list of available traction systems shall contain 31 combinations of NID_CTRACTION with values according to Subset-026 [1], 7.5.1.86.1 and M_VOLTAGE with values according to Subset-026 [1], 7.5.1.78

5.5.4.8.3.2 Note: It has to be considered that new value definitions of NID_CTRACTION are possible due to updates of [11].

5.5.4.8.3.3 Note: The maximum number of traction systems managed by a train is intrinsically limited to 31. This limit comes from the N_ITER variable in train data messages sent to RBC in Subset-026 [1].

5.5.4.8.4 Safety Requirements

5.5.4.8.4.1 Safety requirements shall apply as defined in [13], chapter 2.

5.5.4.9 Train Fitted with Airtight System

5.5.4.9.1 The train interface allows the ETCS on-board to determine the train fitted with airtight system value as follows:

- By selecting/calculating the adequate train fitted with airtight system value based on the "type of train configuration" input.
- By receiving the value of the train fitted with airtight system from the train interface.

5.5.4.9.2 Architecture for transferring the variable via TI

5.5.4.9.2.1 Reference architecture as defined in Chapter 3 or serial connection (bus) as defined in Chapter 4 is allowed.

5.5.4.9.3 Coding

T_FAT_S / TR_OBU_AirTightFitted	Meaning
0	Train not fitted with airtight system.
1	Train fitted with airtight system.

Table 5-48 Coding for Train Fitted with Airtight System

5.5.4.9.4 Safety Requirements

5.5.4.9.4.1 Safety requirements shall apply as defined in [13], chapter 2.

5.6 Additional Data

5.6.1 Train Running Number

5.6.1.1 Architecture

5.6.1.1.1 Only serial connection (bus) as defined in Chapter 4 is allowed.

5.6.1.2 Coding

Name	Size	Meaning
TR_OBU_NID_OPERATION AL	32 bits	For coding refer to NID_OPERATIONAL as defined in [1], 7.5.1.92. The NID_OPERATIONAL consists of up to 8 digits which are entered left adjusted into the data field, the leftmost digit is the digit to be entered first (Binary Coded Decimal). In case the NID_OPERATIONAL is shorter than 8 digits, the remaining space is to be filled with special character "F". For each digit the values from A to E are spare values. "FFFF FFFF" is spare value.

Table 5-49 Coding for Train Running Number

5.6.1.3 Safety Requirements

5.6.1.3.1 Safety requirements shall apply as defined in [13], chapter 2.

5.7 National System Isolation

5.7.1.1 Architecture

5.7.1.1.1 Reference architecture as defined in Chapter 3 or serial connection (bus) as defined in Chapter 4 is allowed.

5.7.1.2 Coding

5.7.1.2.1 Due to the fact that there are multiple existing NTC systems, it shall be possible to configure up to at least 16 (see [3]) signals referring to different national systems.

5.7.1.2.2 Depending on the safety level of the NTC system one signal or two signals are needed.

T_IS_S_Nx / ISSx	Meaning
0	NTCx not isolated
1	NTCx isolated

Table 5-50 Coding for National System Isolated (in case the NTCx safety level requires only one signal)

T_IS_S_Nx / ISSx	T_IS_S_Ix / ISS_Notx	Meaning
0	0	Invalid
0	1	NTCx not isolated
1	0	NTCx isolated
1	1	Invalid

Table 5-51 Coding for National System Isolated (in case the NTCx safety level requires two signals)

5.7.1.3 Safety Requirements

5.7.1.3.1 Safety requirements shall apply as defined in [13], chapter 2.

6. CONFIGURATION MANAGEMENT

6.1.1.1 The following table lists the configuration data related to the Train Interface, which shall be considered for offline agreement.

No.	Configuration Items	Description
1.	cstUUID	Unique consist identifier, UUID of the consist ARRAY[16] OF UNSIGNED8
2.	Train Interface version X applicable for the interface	The applicable Train Interface version X is the version implemented by both the vehicle and the ERTMS/ETCS on-board equipment. X=1: SS-119 ed. 0.0.13 is implemented X=2: SS-119 ed. 1.1.0 is implemented X=3: SS-119 ed. 1.3.0 is implemented
3.	Transient period time t_transient_period_inputs for Boolean OBU Inputs	Unit: ms Range: 0-1000 Resolution: 1 ms
4.	Transient period time t_transient_period_outputs for Boolean OBU Outputs	Unit: ms Range: 0-1000 Resolution: 1 ms
5.	List of traction systems supported by the train	The list shall contain 31 combinations of {M_VOLTAGE; NID_CTRACTION} Coding of NID_CTRACTION: 10 bit variable with values according to Subset-026 [1], 7.5.1.86.1 Coding of M_VOLTAGE: 4 bit variable with values according to Subset-026 [1], 7.5.1.78

6.	Train Data Set based on the “type of train configuration” input.	The following lines of no. 6. describe the elements corresponding to a certain train data set; see coding in 5.5.1.2.5.
	Overall Consist Length	See Table 5-44
	Cant Deficiency	See [1] 7.5.1.82.2.
	Train length	See [1] A.3.11
	Brake model parameter set <ul style="list-style-type: none"> • Traction model • Brake build up time model values based in addition also on the status of special brakes • Speed dependent deceleration model values based in addition also on the status of special brakes • Brake percentage • Brake position • Nominal rotating mass 	<ul style="list-style-type: none"> • T_traction_cut_off as per [1] 3.13.2.2.2.1 • T_brake_emergency values and T_brake_service values, see [1] 3.13.2.2.3.2 • A_brake_emergency(V) and A_brake_service(V), see [1] 3.13.2.2.3.1 • See [1] A.3.11 • See coding in 5.5.4.4.5.3 • Unit: %; resolution: 1%
	Maximum train speed	See [1] A.3.11
	Loading gauge	See [1] A.3.11
	Axle load category	See [1] A.3.11
	Traction system(s) accepted by the engine	See coding in 5.5.4.8.3
	Train fitted with airtight system	See [1] A.3.11 and coding in 5.5.4.9.3
	7.	Way of providing Train Data
Overall Consist Length		
Cant Deficiency		
Train length		

	Brake model parameter set <ul style="list-style-type: none"> • Traction model • Brake build up time model values • Speed dependent deceleration model values • Brake percentage • Brake position • Nominal rotating mass 	
	Maximum train speed	
	Loading gauge	
	Axle load category	
	Traction system(s) accepted by the engine	
	Train fitted with airtight system	
8.	National System Isolation	Configuration which of the available national systems corresponds to which NTC variables NTC1 – NTC16 for NTC Isolation input.

Table 6-1 Configuration data related to the Train Interface

6.1.1.2 Note: For serial bus the user data version (udv) in the SDT trailer (see [17]) is set according to the selected interface version X.



7. APPENDIX A – PROFINET SIGNAL AND PACKET DEFINITIONS

7.1.1 TR Packet 1

TR Packet 1			
Data name	Type	PROFINET signal name	Byte.Bit Offset
Validity1 (part 1)	UNSIGNED8	Q_P1_Valid1_1	0.0
Validity1 (part 2)	UNSIGNED8	Q_P1_Valid1_2	1.0
Validity2 (part 1)	UNSIGNED8	Q_P1_Valid2_1	2.0
Validity2 (part 2)	UNSIGNED8	Q_Spare1	3.0
TR_OBU_TrainSleep	BOOLEAN1	Q_TrainSleep	4.0
TR_OBU_TrainSleep_Not	BOOLEAN1	Q_TrainSleep_N	4.1
TR_OBU_PassiveShunting	BOOLEAN1	Q_PassiveShunt	4.2
TR_OBU_NLEnabled	BOOLEAN1	Q_NLEnabled	4.3
TR_OBU_DirectionFW	BOOLEAN1	Q_DirectionFW	4.4
TR_OBU_DirectionBW	BOOLEAN1	Q_DirectionBW	4.5
TR_OBU_CabStatusA	BOOLEAN1	Q_CabStatusA	4.6
TR_OBU_CabStatusB	BOOLEAN1	Q_CabStatusB	4.7
TR_OBU_TypeTrainData_S1	BOOLEAN1	Q_TypeTrainData1	5.0

© This document has been developed and released by UNISIG in collaboration with Faiveley Transport, Knorr-Bremse, TÜV, Voith Turbo and Vossloh



TR Packet 1			
Data name	Type	PROFINET signal name	Byte.Bit Offset
TR_OBU_TypeTrainData_S2	BOOLEAN1	Q_TypeTrainData2	5.1
Spare1	BOOLEAN1	Q_Spare2	5.2
Spare2	BOOLEAN1	Q_Spare3	5.3
TR_OBU_Traction_Status	BOOLEAN1	Q_TractionStatus	5.4
Spare3	BOOLEAN1	Q_Spare4	5.5
TR_OBU_SetSpeedDisplay	BOOLEAN1	Q_SetSpeedDisp	5.6
Spare4	BOOLEAN1	Q_Spare5	5.7
TR_OBU_BrakePressure	UNSIGNED8	Q_BrkPressure	6.0
TR_OBU_Brake_Status	UNSIGNED8	Q_BrakeStatus	7.0
TR_OBU_NTClolated	UNSIGNED16	Q_NTClisol	8.0
TR_OBU_SetSpeedValue	UNSIGNED16	Q_SetSpeedVal	10.0
TR_OBU_NTClolated_Not	UNSIGNED16	Q_NTClisol_N	12.0

© This document has been developed and released by UNISIG in collaboration with Faiveley Transport, Knorr-Bremse, TÜV, Voith Turbo and Vossloh



7.1.2 TR Packet 2

TR Packet 2			
Data name	Type	PROFINET signal name	Byte.Bit Offset
Validity1 (part 1)	UNSIGNED8	Q_P2_Valid1_1	0.0
Validity1 (part 2)	UNSIGNED8	Q_P2_Valid1_2	1.0
Validity2 (part 1)	UNSIGNED8	Q_P2_Valid2_1	2.0
Validity2 (part 2)	UNSIGNED8	Q_P2_Valid2_2	3.0
Spare1	BOOLEAN1	Q_Spare1	4.0
Spare2	BOOLEAN1	Q_Spare2	4.1
TR_OBU_BrakePosition1	BOOLEAN1	Q_BrakePos1	4.2
TR_OBU_BrakePosition1_Not	BOOLEAN1	Q_BrakePos1_N	4.3
TR_OBU_BrakePosition2	BOOLEAN1	Q_BrakePos2	4.4
TR_OBU_BrakePosition2_Not	BOOLEAN1	Q_BrakePos2_N	4.5
TR_OBU_AirTightFitted	BOOLEAN1	Q_AirTightFitted	4.6
Spare3	BOOLEAN1	Q_Spare3	4.7
TR_OBU_TrainIntegrity_S1	BOOLEAN1	Q_TrainInt_S1	5.0
TR_OBU_TrainIntegrity_S1_Not	BOOLEAN1	Q_TrainInt_S1_N	5.1
TR_OBU_TrainIntegrity_S2	BOOLEAN1	Q_TrainInt_S2	5.2

© This document has been developed and released by UNISIG in collaboration with Faiveley Transport, Knorr-Bremse, TÜV, Voith Turbo and Vossloh



TR Packet 2			
Data name	Type	PROFINET signal name	Byte.Bit Offset
TR_OBU_TrainIntegrity_S2_Not	BOOLEAN1	Q_TrainInt_S2_N	5.3
Spare5	BOOLEAN1	Q_Spare4	5.4
Spare6	BOOLEAN1	Q_Spare5	5.5
Spare8	BOOLEAN1	Q_Spare6	5.6
Spare9	BOOLEAN1	Q_Spare7	5.7
Spare4	UNSIGNED8	Q_Spare8	6.0
TR_OBU_TypeTrainConfiguration	UNSIGNED8	Q_TrainComp	7.0
TR_OBU_BrakePercentage	UNSIGNED8	Q_BrakePerc	8.0
TR_OBU_LoadingGauge	UNSIGNED8	Q_LoadGauge	9.0
TR_OBU_AxleLoadCat	UNSIGNED8	Q_AxleLoadCat	10.0
TR_OBU_TrainCatCantDef	UNSIGNED8	Q_TrainCatCD	11.0
TR_OBU_TrainLength	UNSIGNED16	Q_TrainLength	12.0
Spare10	UNSIGNED16	Q_Spare9	14.0
TR_OBU_SupTractionSys	UNSIGNED32	Q_SupTracSys	16.0
TR_OBU_NID_OPERATIONAL	UNSIGNED32	Q_NidOp	20.0

© This document has been developed and released by UNISIG in collaboration with Faiveley Transport, Knorr-Bremse, TÜV, Voith Turbo and Vossloh



7.1.3 TR Packet 3

TR Packet 3			
Data name	Type	PROFINET signal name	Byte.Bit Offset
Validity1 (part 1)	UNSIGNED8	Q_P3_Valid1_1	0.0
Validity1 (part 2)	UNSIGNED8	Q_Spare1	1.0
Validity2 (part 1)	UNSIGNED8	Q_Spare2	2.0
Validity2 (part 2)	UNSIGNED8	Q_Spare3	3.0
TR_OBU_ L_CONSISTFRONTCABAMAX	UNSIGNED16	Q_L_CFrontCAMax	4.0
TR_OBU_ L_CONSISTFRONTCABAMIN	UNSIGNED16	Q_L_CFrontCAMin	6.0
TR_OBU_ L_CONSISTFRONTCABANOM	UNSIGNED16	Q_L_CFrontCANom	8.0
TR_OBU_ L_CONSISTREARCABAMAX	UNSIGNED16	Q_L_CRearCAMax	10.0
TR_OBU_ L_CONSISTREARCABAMIN	UNSIGNED16	Q_L_CRearCAMin	12.0
TR_OBU_ L_CONSISTREARCABANOM	UNSIGNED16	Q_L_CRearCANom	14.0

© This document has been developed and released by UNISIG in collaboration with Faiveley Transport, Knorr-Bremse, TÜV, Voith Turbo and Vossloh



7.1.4 OBU Packet 1

OBU Packet 1			
Data name	Type	PROFINET signal name	Byte.Bit Offset
Validity1 (part 1)	UNSIGNED8	I_P1_Valid1_1	0.0
Validity1 (part 2)	UNSIGNED8	I_P1_Valid1_2	1.0
Validity2 (part 1)	UNSIGNED8	I_P1_Valid2_1	2.0
Validity2 (part 2)	UNSIGNED8	I_Spare1	3.0
OBU_TR_ServiceBrake	BOOLEAN1	I_ServiceBrake	4.0
OBU_TR_EB3_Cmd	BOOLEAN1	I_EB3_Cmd	4.1
OBU_TR_TCO_Cmd	BOOLEAN1	I_TCO_Cmd	4.2
OBU_TR_RBInhibit_Cmd	BOOLEAN1	I_RBInhibit_Cmd	4.3
OBU_TR_MGInhibit_Cmd	BOOLEAN1	I_MGInhibit_Cmd	4.4
OBU_TR_ECSEInhibit_Cmd	BOOLEAN1	I_ECSEInhibit_Cmd	4.5
OBU_TR_ECEInhibit_Cmd	BOOLEAN1	I_ECEInhibit_Cmd	4.6
OBU_TR_AT_Cmd	BOOLEAN1	I_AT_Cmd	4.7
OBU_TR_MPS_Cmd	BOOLEAN1	I_MPS_Cmd	5.0
OBU_TR_PG_Cmd	BOOLEAN1	I_PG_Cmd	5.1
OBU_TR_AD_Status	BOOLEAN1	I_AD_Status	5.2

© This document has been developed and released by UNISIG in collaboration with Faiveley Transport, Knorr-Bremse, TÜV, Voith Turbo and Vossloh



OBU Packet 1			
Data name	Type	PROFINET signal name	Byte.Bit Offset
OBU_TR_RS_Status	BOOLEAN1	I_RS_Status	5.3
Spare1	BOOLEAN1	I_Spare2	5.4
Spare2	BOOLEAN1	I_Spare3	5.5
Spare3	BOOLEAN1	I_Spare4	5.6
OBU_TR_EngOrientSM	BOOLEAN1	I_EngOrientSM	5.7
Spare4 (part 1)	UNSIGNED8	I_Spare5	6.0
Spare4 (part 2)	UNSIGNED8	I_Spare6	7.0
OBU_TR_CTS_NewVoltage	UNSIGNED8	I_CTS_NewVolt	8.0
Spare5	UNSIGNED8	I_Spare7	9.0
OBU_TR_CTS_NewId	UNSIGNED16	I_CTS_NewId	10.0
OBU_TR_ACC_Limit	UNSIGNED16	I_ACC_Limit	12.0
OBU_TR_CTS_D_Change	INTEGER16	I_CTS_D_Change	14.0
OBU_TR_ACC_D_Change	INTEGER16	I_ACC_D_Change	16.0

© This document has been developed and released by UNISIG in collaboration with Faiveley Transport, Knorr-Bremse, TÜV, Voith Turbo and Vossloh



7.1.5 OBU Station Platform (OBU Packet 2)

OBU Station Platform			
Data name	Type	PROFINET signal name	Byte.Bit Offset
Validity1	BOOLEAN1	I_P2_Valid1	0.0
Validity2	BOOLEAN1	I_P2_Valid2	0.1
Validity3	BOOLEAN1	I_P2_Valid3	0.2
Validity4	BOOLEAN1	I_P2_Valid4	0.3
Validity5	BOOLEAN1	I_P2_Valid5	0.4
Spare1	BOOLEAN1	I_Spare1	0.5
Spare2	BOOLEAN1	I_Spare2	0.6
Spare3	BOOLEAN1	I_Spare3	0.7
OBU_TR_SP_Left1	BOOLEAN1	I_SP_Left1	1.0
OBU_TR_SP_Right1	BOOLEAN1	I_SP_Right1	1.1
Spare4	BOOLEAN1	I_Spare4	1.2
Spare5	BOOLEAN1	I_Spare5	1.3
OBU_TR_SP_Height1_Bit0	BOOLEAN1	I_SP_Height1_B0	1.4
OBU_TR_SP_Height1_Bit1	BOOLEAN1	I_SP_Height1_B1	1.5

© This document has been developed and released by UNISIG in collaboration with Faiveley Transport, Knorr-Bremse, TÜV, Voith Turbo and Vossloh



OBU Station Platform			
Data name	Type	PROFINET signal name	Byte.Bit Offset
OBU_TR_SP_Height1_Bit2	BOOLEAN1	I_SP_Height1_B2	1.6
OBU_TR_SP_Height1_Bit3	BOOLEAN1	I_SP_Height1_B3	1.7
OBU_TR_SP_Left2	BOOLEAN1	I_SP_Left2	2.0
OBU_TR_SP_Right2	BOOLEAN1	I_SP_Right2	2.1
Spare6	BOOLEAN1	I_Spare6	2.2
Spare7	BOOLEAN1	I_Spare7	2.3
OBU_TR_SP_Height2_Bit0	BOOLEAN1	I_SP_Height2_B0	2.4
OBU_TR_SP_Height2_Bit1	BOOLEAN1	I_SP_Height2_B1	2.5
OBU_TR_SP_Height2_Bit2	BOOLEAN1	I_SP_Height2_B2	2.6
OBU_TR_SP_Height2_Bit3	BOOLEAN1	I_SP_Height2_B3	2.7
OBU_TR_SP_Left3	BOOLEAN1	I_SP_Left3	3.0
OBU_TR_SP_Right3	BOOLEAN1	I_SP_Right3	3.1
Spare8	BOOLEAN1	I_Spare8	3.2
Spare9	BOOLEAN1	I_Spare9	3.3
OBU_TR_SP_Height3_Bit0	BOOLEAN1	I_SP_Height3_B0	3.4
OBU_TR_SP_Height3_Bit1	BOOLEAN1	I_SP_Height3_B1	3.5

© This document has been developed and released by UNISIG in collaboration with Faiveley Transport, Knorr-Bremse, TÜV, Voith Turbo and Vossloh



OBU Station Platform			
Data name	Type	PROFINET signal name	Byte.Bit Offset
OBU_TR_SP_Height3_Bit2	BOOLEAN1	I_SP_Height3_B2	3.6
OBU_TR_SP_Height3_Bit3	BOOLEAN1	I_SP_Height3_B3	3.7
OBU_TR_SP_Left4	BOOLEAN1	I_SP_Left4	4.0
OBU_TR_SP_Right4	BOOLEAN1	I_SP_Right4	4.1
Spare10	BOOLEAN1	I_Spare10	4.2
Spare11	BOOLEAN1	I_Spare11	4.3
OBU_TR_SP_Height4_Bit0	BOOLEAN1	I_SP_Height4_B0	4.4
OBU_TR_SP_Height4_Bit1	BOOLEAN1	I_SP_Height4_B1	4.5
OBU_TR_SP_Height4_Bit2	BOOLEAN1	I_SP_Height4_B2	4.6
OBU_TR_SP_Height4_Bit3	BOOLEAN1	I_SP_Height4_B3	4.7
OBU_TR_SP_Left5	BOOLEAN1	I_SP_Left5	5.0
OBU_TR_SP_Right5	BOOLEAN1	I_SP_Right5	5.1
Spare12	BOOLEAN1	I_Spare12	5.2
Spare13	BOOLEAN1	I_Spare13	5.3
OBU_TR_SP_Height5_Bit0	BOOLEAN1	I_SP_Height5_B0	5.4
OBU_TR_SP_Height5_Bit1	BOOLEAN1	I_SP_Height5_B1	5.5

© This document has been developed and released by UNISIG in collaboration with Faiveley Transport, Knorr-Bremse, TÜV, Voith Turbo and Vossloh



OBU Station Platform			
Data name	Type	PROFINET signal name	Byte.Bit Offset
OBU_TR_SP_Height5_Bit2	BOOLEAN1	I_SP_Height5_B2	5.6
OBU_TR_SP_Height5_Bit3	BOOLEAN1	I_SP_Height5_B3	5.7
OBU_TR_SP_D_Entry1	INTEGER16	I_SP_D_Entry1	6.0
OBU_TR_SP_D_Exit1	INTEGER16	I_SP_D_Exit1	8.0
OBU_TR_SP_D_Entry2	INTEGER16	I_SP_D_Entry2	10.0
OBU_TR_SP_D_Exit2	INTEGER16	I_SP_D_Exit2	12.0
OBU_TR_SP_D_Entry3	INTEGER16	I_SP_D_Entry3	14.0
OBU_TR_SP_D_Exit3	INTEGER16	I_SP_D_Exit3	16.0
OBU_TR_SP_D_Entry4	INTEGER16	I_SP_D_Entry4	18.0
OBU_TR_SP_D_Exit4	INTEGER16	I_SP_D_Exit4	20.0
OBU_TR_SP_D_Entry5	INTEGER16	I_SP_D_Entry5	22.0
OBU_TR_SP_D_Exit5	INTEGER16	I_SP_D_Exit5	24.0

© This document has been developed and released by UNISIG in collaboration with Faiveley Transport, Knorr-Bremse, TÜV, Voith Turbo and Vossloh



7.1.6 OBU Packet 3

OBU Packet 3				
Data name (structure and fixed generic content)	Type	Default values	PROFINET signal name	Byte.Bit Offset
Validity (part 1)	UNSIGNED8	-	I_P3_Valid_1	0.0
Validity (part 2)	UNSIGNED8	-	I_P3_Valid_2	1.0
OBU_TR_TC_ID1	UNSIGNED8	-	I_TC_ID1	2.0
OBU_TR_TC_ID2	UNSIGNED8	-	I_TC_ID2	3.0
OBU_TR_TC_ID3	UNSIGNED8	-	I_TC_ID3	4.0
OBU_TR_TC_ID4	UNSIGNED8	-	I_TC_ID4	5.0
OBU_TR_TC_TYPE1	UNSIGNED8	-	I_TC_TYPE1	6.0
OBU_TR_TC_TYPE2	UNSIGNED8	-	I_TC_TYPE2	7.0
OBU_TR_TC_TYPE3	UNSIGNED8	-	I_TC_TYPE3	8.0
OBU_TR_TC_TYPE4	UNSIGNED8	-	I_TC_TYPE4	9.0
OBU_TR_D_ENTRY1	INTEGER16	-	I_D_ENTRY1	10.0
OBU_TR_D_ENTRY2	INTEGER16	-	I_D_ENTRY2	12.0
OBU_TR_D_ENTRY3	INTEGER16	-	I_D_ENTRY3	14.0
OBU_TR_D_ENTRY4	INTEGER16	-	I_D_ENTRY4	16.0
OBU_TR_D_EXIT1	INTEGER16	-	I_D_EXIT1	18.0

© This document has been developed and released by UNISIG in collaboration with Faiveley Transport, Knorr-Bremse, TÜV, Voith Turbo and Vossloh



OBU Packet 3				
Data name (structure and fixed generic content)	Type	Default values	PROFINET signal name	Byte.Bit Offset
OBU_TR_D_EXIT2	INTEGER16	-	I_D_EXIT2	20.0
OBU_TR_D_EXIT3	INTEGER16	-	I_D_EXIT3	22.0
OBU_TR_D_EXIT4	INTEGER16	-	I_D_EXIT4	24.0

7.1.7 OBU Packet 4

OBU Packet 4				
Data name (structure and fixed generic content)	Type	Default values	PROFINET signal name	Byte.Bit Offset
Validity (part 1)	UNSIGNED8	-	I_P4_Valid_1	0.0
Validity (part 2)	UNSIGNED8	-	I_P4_Valid_2	1.0
OBU_TR_TC_ID5	UNSIGNED8	-	I_TC_ID5	2.0
OBU_TR_TC_ID6	UNSIGNED8	-	I_TC_ID6	3.0
OBU_TR_TC_ID7	UNSIGNED8	-	I_TC_ID7	4.0
OBU_TR_TC_ID8	UNSIGNED8	-	I_TC_ID8	5.0
OBU_TR_TC_TYPE5	UNSIGNED8	-	I_TC_TYPE5	6.0
OBU_TR_TC_TYPE6	UNSIGNED8	-	I_TC_TYPE6	7.0

© This document has been developed and released by UNISIG in collaboration with Faiveley Transport, Knorr-Bremse, TÜV, Voith Turbo and Vossloh



OBU Packet 4				
Data name (structure and fixed generic content)	Type	Default values	PROFINET signal name	Byte.Bit Offset
OBU_TR_TC_TYPE7	UNSIGNED8	-	I_TC_TYPE7	8.0
OBU_TR_TC_TYPE8	UNSIGNED8	-	I_TC_TYPE8	9.0
OBU_TR_D_ENTRY5	INTEGER16	-	I_D_ENTRY5	10.0
OBU_TR_D_ENTRY6	INTEGER16	-	I_D_ENTRY6	12.0
OBU_TR_D_ENTRY7	INTEGER16	-	I_D_ENTRY7	14.0
OBU_TR_D_ENTRY8	INTEGER16	-	I_D_ENTRY8	16.0
OBU_TR_D_EXIT5	INTEGER16	-	I_D_EXIT5	18.0
OBU_TR_D_EXIT6	INTEGER16	-	I_D_EXIT6	20.0
OBU_TR_D_EXIT7	INTEGER16	-	I_D_EXIT7	22.0
OBU_TR_D_EXIT8	INTEGER16	-	I_D_EXIT8	24.0

7.1.8 OBU Packet 5

OBU Packet 5				
Data name (structure and fixed generic content)	Type	Default values	PROFINET signal name	Byte.Bit Offset
Validity (part 1)	UNSIGNED8	-	I_P5_Valid_1	0.0

© This document has been developed and released by UNISIG in collaboration with Faiveley Transport, Knorr-Bremse, TÜV, Voith Turbo and Vossloh



OBU Packet 5				
Data name (structure and fixed generic content)	Type	Default values	PROFINET signal name	Byte.Bit Offset
Validity (part 2)	UNSIGNED8	-	I_P5_Valid_2	1.0
OBU_TR_TC_ID9	UNSIGNED8	-	I_TC_ID9	2.0
OBU_TR_TC_ID10	UNSIGNED8	-	I_TC_ID10	3.0
OBU_TR_TC_ID11	UNSIGNED8	-	I_TC_ID11	4.0
OBU_TR_TC_ID12	UNSIGNED8	-	I_TC_ID12	5.0
OBU_TR_TC_TYPE9	UNSIGNED8	-	I_TC_TYPE9	6.0
OBU_TR_TC_TYPE10	UNSIGNED8	-	I_TC_TYPE10	7.0
OBU_TR_TC_TYPE11	UNSIGNED8	-	I_TC_TYPE11	8.0
OBU_TR_TC_TYPE12	UNSIGNED8	-	I_TC_TYPE12	9.0
OBU_TR_D_ENTRY9	INTEGER16	-	I_D_ENTRY9	10.0
OBU_TR_D_ENTRY10	INTEGER16	-	I_D_ENTRY10	12.0
OBU_TR_D_ENTRY11	INTEGER16	-	I_D_ENTRY11	14.0
OBU_TR_D_ENTRY12	INTEGER16	-	I_D_ENTRY12	16.0
OBU_TR_D_EXIT9	INTEGER16	-	I_D_EXIT9	18.0
OBU_TR_D_EXIT10	INTEGER16	-	I_D_EXIT10	20.0
OBU_TR_D_EXIT11	INTEGER16	-	I_D_EXIT11	22.0

© This document has been developed and released by UNISIG in collaboration with Faiveley Transport, Knorr-Bremse, TÜV, Voith Turbo and Vossloh



OBU Packet 5				
Data name (structure and fixed generic content)	Type	Default values	PROFINET signal name	Byte.Bit Offset
OBU_TR_D_EXIT12	INTEGER16	-	I_D_EXIT12	24.0

7.1.9 OBU Packet 6

OBU Packet 6				
Data name (structure and fixed generic content)	Type	Default values	PROFINET signal name	Byte.Bit Offset
Validity (part 1)	UNSIGNED8	-	I_P6_Valid_1	0.0
Validity (part 2)	UNSIGNED8	-	I_P6_Valid_2	1.0
OBU_TR_TC_ID13	UNSIGNED8	-	I_TC_ID13	2.0
OBU_TR_TC_ID14	UNSIGNED8	-	I_TC_ID14	3.0
OBU_TR_TC_ID15	UNSIGNED8	-	I_TC_ID15	4.0
OBU_TR_TC_ID16	UNSIGNED8	-	I_TC_ID16	5.0
OBU_TR_TC_TYPE13	UNSIGNED8	-	I_TC_TYPE13	6.0
OBU_TR_TC_TYPE14	UNSIGNED8	-	I_TC_TYPE14	7.0
OBU_TR_TC_TYPE15	UNSIGNED8	-	I_TC_TYPE15	8.0
OBU_TR_TC_TYPE16	UNSIGNED8	-	I_TC_TYPE16	9.0

© This document has been developed and released by UNISIG in collaboration with Faiveley Transport, Knorr-Bremse, TÜV, Voith Turbo and Vossloh



OBU Packet 6				
Data name (structure and fixed generic content)	Type	Default values	PROFINET signal name	Byte.Bit Offset
OBU_TR_D_ENTRY13	INTEGER16	-	I_D_ENTRY13	10.0
OBU_TR_D_ENTRY14	INTEGER16	-	I_D_ENTRY14	12.0
OBU_TR_D_ENTRY15	INTEGER16	-	I_D_ENTRY15	14.0
OBU_TR_D_ENTRY16	INTEGER16	-	I_D_ENTRY16	16.0
OBU_TR_D_EXIT13	INTEGER16	-	I_D_EXIT13	18.0
OBU_TR_D_EXIT14	INTEGER16	-	I_D_EXIT14	20.0
OBU_TR_D_EXIT15	INTEGER16	-	I_D_EXIT15	22.0
OBU_TR_D_EXIT16	INTEGER16	-	I_D_EXIT16	24.0

7.1.10 OBU Packet 7

OBU Packet 7				
Data name (structure and fixed generic content)	Type	Default values	PROFINET signal name	Byte.Bit Offset
Validity (part 1)	UNSIGNED8	-	I_P7_Valid_1	0.0
Validity (part 2)	UNSIGNED8	-	I_P7_Valid_2	1.0
OBU_TR_TC_ID17	UNSIGNED8	-	I_TC_ID17	2.0

© This document has been developed and released by UNISIG in collaboration with Faiveley Transport, Knorr-Bremse, TÜV, Voith Turbo and Vossloh



OBU Packet 7				
Data name (structure and fixed generic content)	Type	Default values	PROFINET signal name	Byte.Bit Offset
OBU_TR_TC_ID18	UNSIGNED8	-	I_TC_ID18	3.0
OBU_TR_TC_ID19	UNSIGNED8	-	I_TC_ID19	4.0
OBU_TR_TC_ID20	UNSIGNED8	-	I_TC_ID20	5.0
OBU_TR_TC_TYPE17	UNSIGNED8	-	I_TC_TYPE17	6.0
OBU_TR_TC_TYPE18	UNSIGNED8	-	I_TC_TYPE18	7.0
OBU_TR_TC_TYPE19	UNSIGNED8	-	I_TC_TYPE19	8.0
OBU_TR_TC_TYPE20	UNSIGNED8	-	I_TC_TYPE20	9.0
OBU_TR_D_ENTRY17	INTEGER16	-	I_D_ENTRY17	10.0
OBU_TR_D_ENTRY18	INTEGER16	-	I_D_ENTRY18	12.0
OBU_TR_D_ENTRY19	INTEGER16	-	I_D_ENTRY19	14.0
OBU_TR_D_ENTRY20	INTEGER16	-	I_D_ENTRY20	16.0
OBU_TR_D_EXIT17	INTEGER16	-	I_D_EXIT17	18.0
OBU_TR_D_EXIT18	INTEGER16	-	I_D_EXIT18	20.0
OBU_TR_D_EXIT19	INTEGER16	-	I_D_EXIT19	22.0
OBU_TR_D_EXIT20	INTEGER16	-	I_D_EXIT20	24.0

© This document has been developed and released by UNISIG in collaboration with Faiveley Transport, Knorr-Bremse, TÜV, Voith Turbo and Vossloh