



INTEROPERABILITY UNIT

**TAP TSI: ANNEX B.7
INTERNATIONAL RAIL TICKET FOR HOME PRINTING**

REFERENCE: ERA/TD/2009-10/INT	DOCUMENT TYPE: TECHNICAL DOCUMENT
VERSION: 1.1.1 FINAL	TAP TSI
DATE: 08.03.2012	

AMENDMENT RECORD

Version	Date	Section number	Modification/description
1.1	05.05.2011	All sections	First release
1.1.1	27.09.2011	5.2.1, 5.4, 5.6, 5.7	New version "TAP_TSI_B.7_v1.1.1.xsd" scheme added

Introduction

The present document belongs to the set of Technical Documents described in Annex III 'List of Technical Documents referenced in this TSI' of the COMMISSION REGULATION (EU) No 454/2011.

International Rail Ticket for Home Printing

Application :

With effect from 08 March 2012.

All actors of the European Union falling under the provisions of the TAP TSI of the European Union

Contents

Summary	9
1 - Mechanism	10
2 - What is covered by this standard?	12
3 - Layout.....	13
3.1 - General issues.....	13
3.2 - The different zones explained in detail	14
3.2.1 - The distributor zone (8).....	16
3.2.2 - The adapted RCT2 layout ("the RCT2 zone" - (7)).....	16
3.2.3 - The reservation zone (6).....	17
3.2.4 - The certificates zones - the 2D certificate zone (2, 3, 4)	18
3.2.5 - The page number zone (5)	20
3.2.6 - The free distributor zone (1).....	20
3.3 - Type of tickets covered by this standard.....	23
3.4 - Adapted RCT2 layout for the different types of ticket.....	23
3.4.1 - Non Reservation Ticket	23
3.4.2 - Non Reservation Ticket + reservation	24
3.4.3 - Non Reservation Ticket + supplement	24
3.4.4 - Non Reservation Ticket + reservation + supplement.....	25
3.4.5 - Integrated Reservation Ticket	25
4 - The certificates	26
4.1 - "Carrier Makes Certificate - CMC"	26
4.2 - "Carrier keeps contract - CKC"	27
4.3 - Digitally Signed Ticket (DST)	28
4.4 - Combinations.....	28
4.5 - Layout of the certificate zones	29
4.6 - Checking of the certificates.....	29
5 - Security services (CMC, CKC).....	30
5.1 - Mechanism	30
5.2 - Certificate request string.....	30
5.2.1 - Layout of the certificate request string	30
5.2.2 - General fields	31
5.2.3 - Passenger fields	32
5.2.4 - Non Reservation Tickets fields.....	33
5.2.5 - Reservation fields	34

5.3 - Certificate generation.....	35
5.4 - Certificate transfer	35
5.5 - Important remark about list of TCOs per train - multiple TCO's/segment	37
5.6 - Cancellation message	38
5.7 - Cancellation acknowledgement	39
6 - Class diagrams of the different messages.....	40
6.1 - Overview of the messages	40
6.2 - Detailed specification of the classes.....	44
6.2.1 - "Message" class	44
6.2.2 - "Distributor" class.....	45
6.2.3 - "Supplement" class.....	45
6.2.4 - "Station" class [harmonize with TAP Glossary?]	45
6.2.5 - "Segments" class.....	45
6.2.6 - "ReferenceID" class.....	46
6.2.7 - "TariffCharacteristics" class	46
6.2.8 - "Ticket" class	46
6.2.9 - "TicketHolder" class.....	47
6.2.10 - "Passenger" class.....	47
6.2.11 - "Train" class.....	48
6.2.12 - "Error" class.....	48
6.2.13 - "FreeText" class.....	48
6.2.14 - "IdentificationType" class.....	49
6.2.15 - "Date" class.....	49
6.2.16 - "TCO" class.....	49
6.2.17 - "SecurityString" class	49
6.2.18 - "StringLayout" class.....	49
6.2.19 - "CancellationReason" class.....	49
6.2.20 - "Cancellation" class.....	49
6.2.21 - "RecordNumber" class	50
6.2.22 - "CertificateRequest" class	50
6.3 - Use cases.....	51
6.3.1 - Description	51
6.3.2 - "Distributor_" actor.....	52
6.3.3 - "TCO 1" actor	52
6.3.4 - "CertificateCancellation" use case	52
6.3.5 - "CancellationAcknowledgment" use case	52
6.3.6 - "ReceiveAcknowledgment" use case	52

7 - Messaging process + exceptions in messaging (CMC, CKC)	53
7.1 - Sequence in messaging	53
7.2 - Messaging sequence diagrams	54
8 - Specification of Digitally Signed Ticket (DST)	56
8.1 - Mechanism	56
8.1.1 - Introduction.....	56
8.1.2 - Composition of the DST content	57
8.1.3 - Control of the DST	58
8.1.4 - Compressing procedure.....	59
8.1.5 - Character encoding	59
8.2 - Definition of the record structure.....	60
8.3 - Definitions of the general record types	61
8.4 - Definition of the record types for the ticket data according to the TAP TSI standard	62
8.4.1 - Extraction of RCT 2 zones	64
8.4.2 - Extraction of RCT2 ticket attributes.....	65
8.5 - Record types for ticket data in accordance with the standards of a specific TCO	66
8.6 - Definition of the entire DST message structure	67
8.7 - 2D Barcode symbol	68
8.8 - Key management.....	69
8.8.1 - Duration of validity of the signature key	69
8.8.2 - Test key pairs	69
8.8.3 - Exchange of signature keys (public keys) with partner companies.....	70
9 - Option: list with cancelled certificates (CMC, CKC)	71
10 -Procedure for making home-printed tickets	73
List of abbreviations	74
Bibliography	75

Summary

This document describes the standard for home-printed tickets to be used in international carriage by train (a typical result of Internet sale). Home-printed railway tickets are already used for national transport. This standard describes how these tickets can be used in an international context.

Since some trains belong to one carrier, but the check on board is done by another carrier or more than one carrier, we will define TCO: "Ticket Controlling Organisation". This is any organisation which can control a passenger's ticket before, during or after a given journey (or part of it). In most cases this organisation will be a carrier or a subcontractor of a carrier.

N.B: A distributor can only sell international tickets in home-printing if it has a bilateral agreement with every TCO involved in the journey.

The agreement must precise the service levels (for example the response time) and the types of tickets which can be sold (legal aspects). Furthermore, all the information the TCO needs to produce a security-zone must be defined. To identify a passenger, one TCO uses the data on the credit card, another TCO uses the identity-card, a third company doesn't even ask for identification. Obviously, the distributor must request many different information from the client in order to send it to each TCO.

The agreement must also describe the conditions for using the ticket and the actions to be taken in case of an irregularity (e.g. fraud). All the options, described in this standard, must be described in the bilateral agreement.

The standard describes the mandatory layout of the home printed tickets and the messages that need to be exchanged between the TCOs and the distributors in order to create those tickets. The existing procedures (e.g. asking for availability of a train seat in a reservation, calculation of price of a ticket, ...) which are not specific to this kind of ticketing are part of other existing ERA TAP TSI Technical Documents i.e. B.5 and B.6.

The standard is voluntarily very "open" in order to guarantee the railway undertakings a large choice of mechanisms to generate the certificates so that the TCOs can re-use their existing national standards and algorithms. Besides, the standard will not be accepted just like that in all the European trains. An E-ticket will only be made in dialogue with the TCO(s) in question. Only on the basis of a bilateral agreement, the TCO will generate a certificate for a distributor.

In this bilateral agreement, there will be a description of the kind of tickets which can be printed. It will be specified whether one ticket can be used for one or many reservation(s), what certificate mechanism to use, which elements are necessary to generate the certificates, which layout will be used to put the certificate on the ticket, if the distributor can place a picture in the background of the adapted RCT2 zone or not..

1 - Mechanism

The terms "Passenger" and "Client" are used in this Technical Document. They can be one and the same person but not necessarily. For example a passenger may take an international train journey using a ticket that was bought by his/her firm. In that case the firm is the client.

It is thus possible to distinguish between the client who buys the ticket and the passenger who is travelling. If several passengers are travelling together, one passenger must be defined as "head of the group". His or her personal data will be used to generate the certificate(s).

The distributor communicates with the client in order to produce a ticket. For this purpose, they exchange the same information as when the client buys his/her ticket at a selling point. The distributor can compose a ticket autonomously or through a connection with the different reservation systems necessary for creating the ticket.

This procedure is completely identical to the procedure of buying a normal ticket from a selling point and is therefore not a part of this standard.

Phase 1: The client books his/her ticket from the distributor via the Internet.

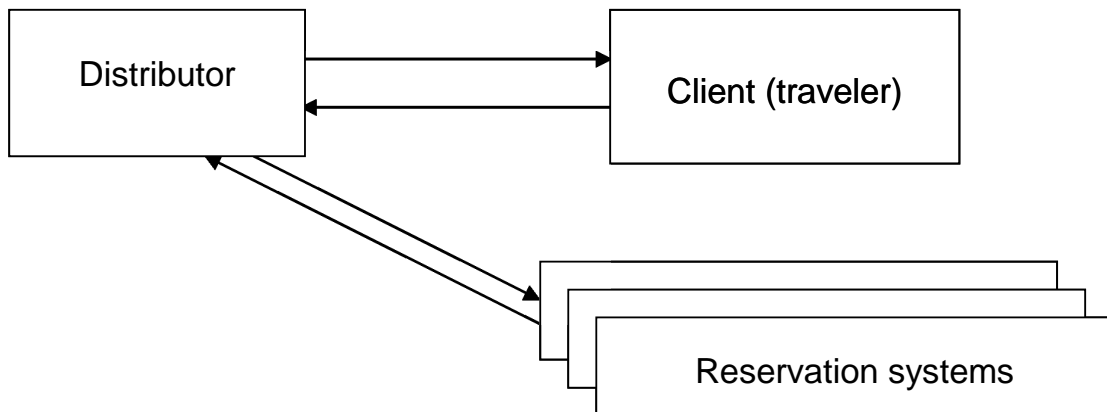

Fig. 1 – Booking

Phase 2: The distributor knows the itinerary and the travelling details and prepares the certificate request string.

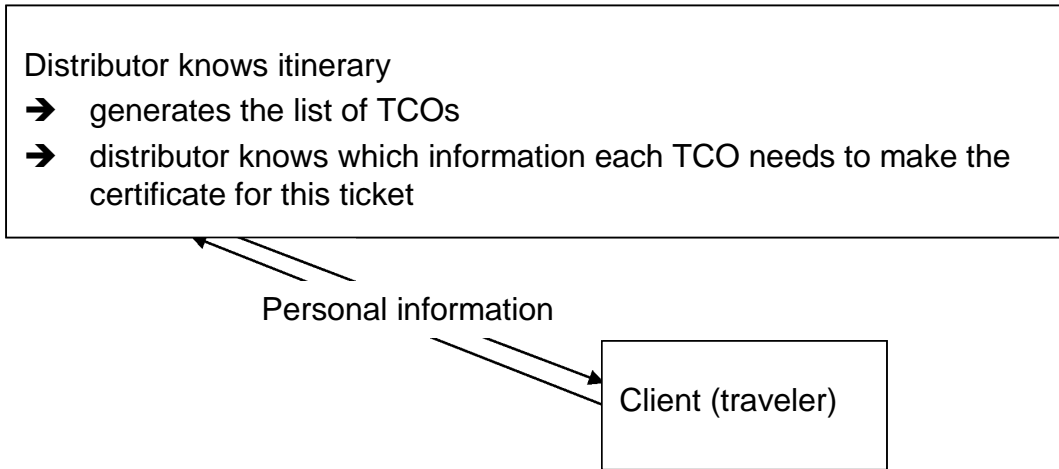

Fig. 2 - Preparing requests

Phase 3: The different TCOs concerned are being contacted to provide the certificate.

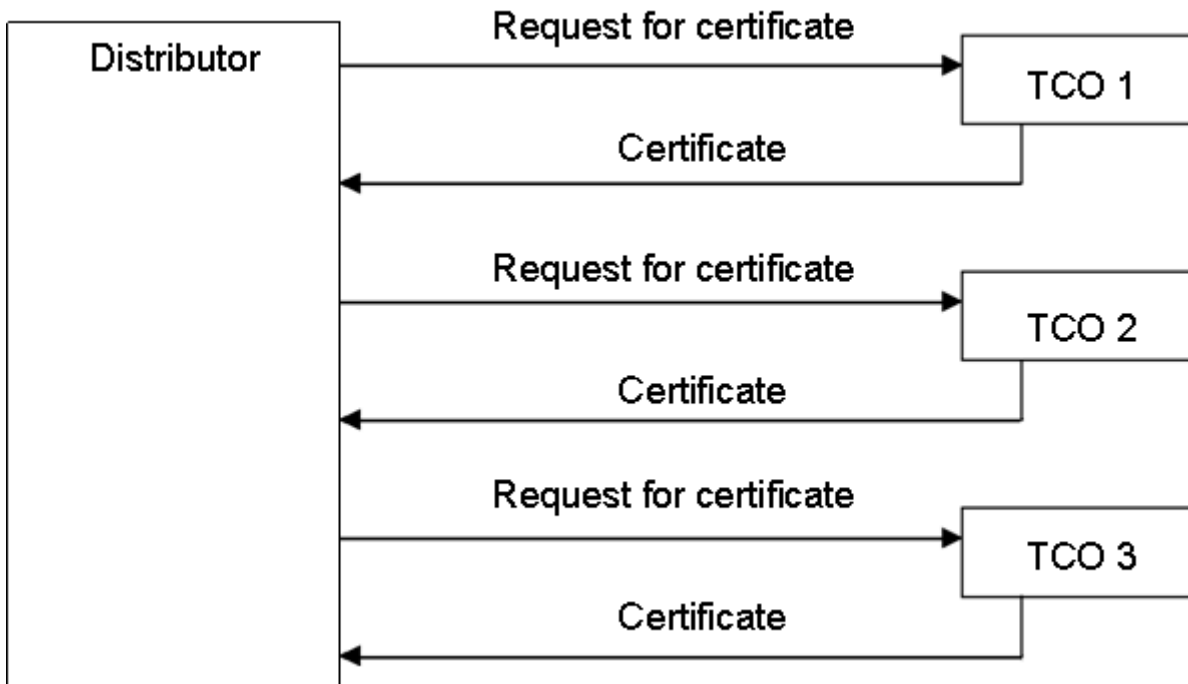

Fig. 3 - Communication Distributor - TCOs

Phase 4: The distributor creates the ticket with a standardised layout and sends it to the client.

The payment action is also part of the procedure, but depending on the distributor (and its relation with the client) this can be done earlier or later in the chain.

2 - What is covered by this standard?

The whole chain (buying a home printed ticket via the Internet) is shown in this diagram:

Distributor :

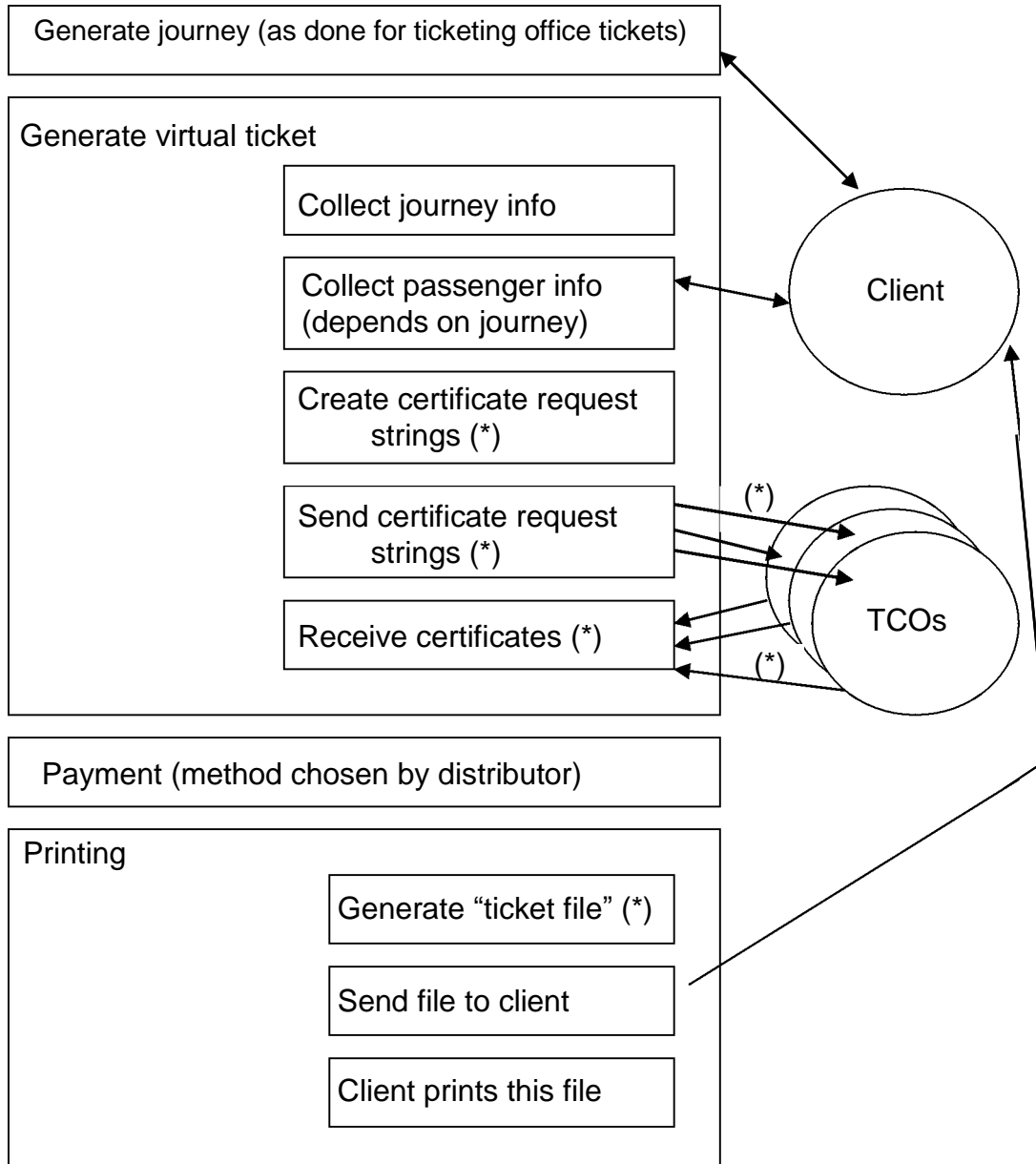

Fig. 4 - The home-printed ticketing scheme

The parts marked with an asterisk (*) are part of the standard.

The list of ticket types that are covered by this standard can be found in point 3.3.

3 - Layout

3.1 - General issues

The ticket is divided in 3 parts:

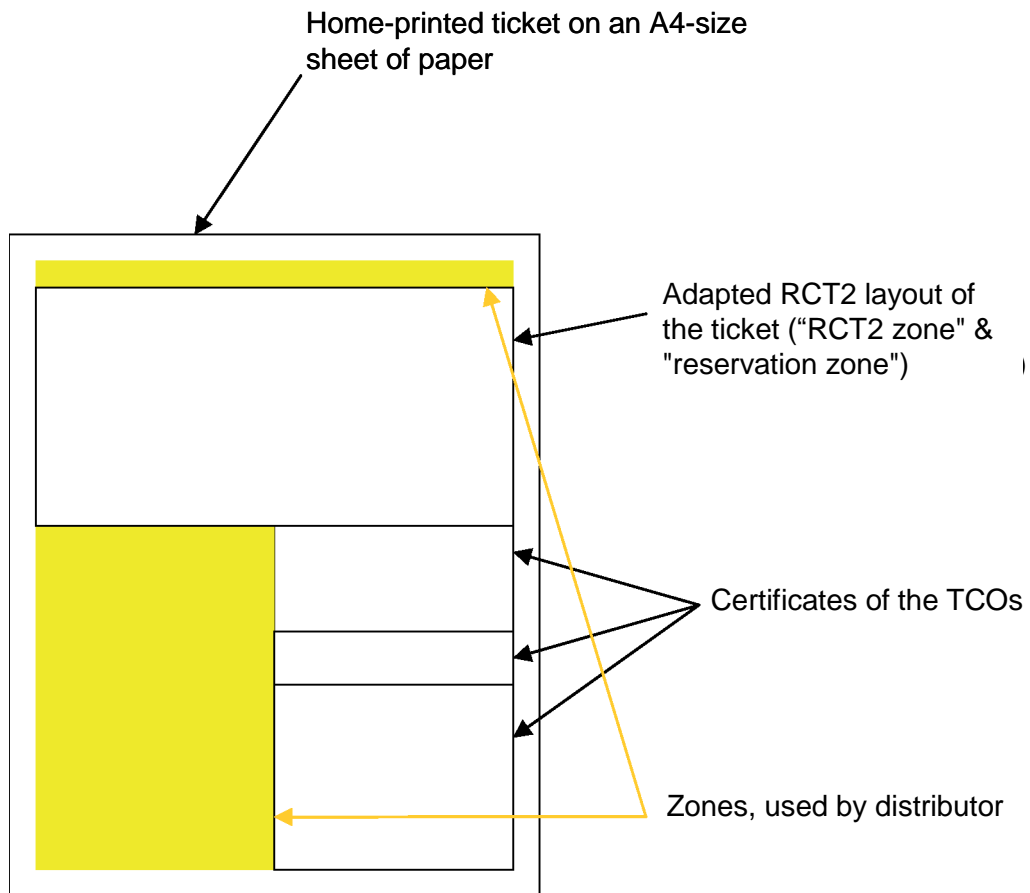

Fig. 5 - Home-printed ticket layout

In the yellow (shaded) zones the distributor can put any information it wishes, for example a reference to its file, a timetable, the conditions for using the ticket.

The top-zone is fixed and must be used to identify the distributor and the issuer. If the distributor is the issuer, only one representation will be enough. The layout is free (logo and/or text).

The RCT2 zone contains the information concerning the journey and the ticket as stated in ERA TAP TSI Technical Document B.6, information which is used by the undertakings in order to control the journey and passenger info on the ticket. Possibly, a line will be added just beneath containing information about a reservation and/or a supplement. ERA TAP TSI Technical Document B.6 doesn't permit an Non Reservation ticket + reservation on one ticket, the home printed version however must allow this combination.

The adapted RCT2 zone **MUST ALWAYS** contain the name of the/a passenger.

The lines "certificates of the TCOs" contain the Company code of the TCO, described in ERA TAP TSI Technical Document B.8, the location codes of the boarding and destination stations (or the code(s) of the border(s)), described in ERA TAP TSI Technical Document B.9, plus the certificate itself. Each TCO must have its own code since it can have its own ticket control devices. .

If the train leaves and arrives in the control zone of the TCO, the certificate zone indicates the actual boarding and destination stations. In the opposite case, when the train passes to another operator, the name of the station is replaced by the unique location code of the border.

Each company which may have to control the ticket will generate a certificate: an ASCII-string in answer to a question-string. The question-string must contain all the elements the TCO needs to create the security-part.

The designation of the contract of carriage (e.g. "TICKET", "TICKET+RESERVATION", ...) must be in the language of the interface of the website the client visited to generate this ticket. This information may also appear additionally in other languages.

The distributor may draw a line on the ticket to indicate that the client can travel with only the part above this line (no relevant information is found under this line). The client may then cut this ticket in two parts and use only the upper part.

3.2 - The different zones explained in detail

On the A4-printed ticket, the different zones are named as shown below and on the diagram in Fig 7:

(1)	FREE ZONE (DISTRIBUTOR - point 3.2.6)
(2)	CERTIFICATES ZONE I (OBLIGATION, VARIABLE SIZE - point 3.2.4)
(3)	CERTIFICATES ZONE II (IF NEEDED, ELSE: FREE ZONE - point 3.2.4)
(4)	2D-BARCODE-ZONE (IF ANY, ELSE: CERTIFICATE ZONE - point 3.2.4)
(5)	PAGE NUMBER (OBLIGATION - point 3.2.5)
(6)	RESERVATION ZONE (VARIABLE SIZE - point 3.2.3)
(7)	TICKET DATA (RCT2 ADAPTED ZONE, OBLIGATION - point 3.2.2)
(8)	DISTRIBUTION ZONE (OBLIGATION) - point 3.2.1)

Fig. 6 - Legend of the different zones as shown in Figure 7

The colors are used to indicate where the different zones can be found on the physical ticket (see Fig. 6). The size of the different zones is written in the description of the zone itself.

The size of the paper is defined as A4.

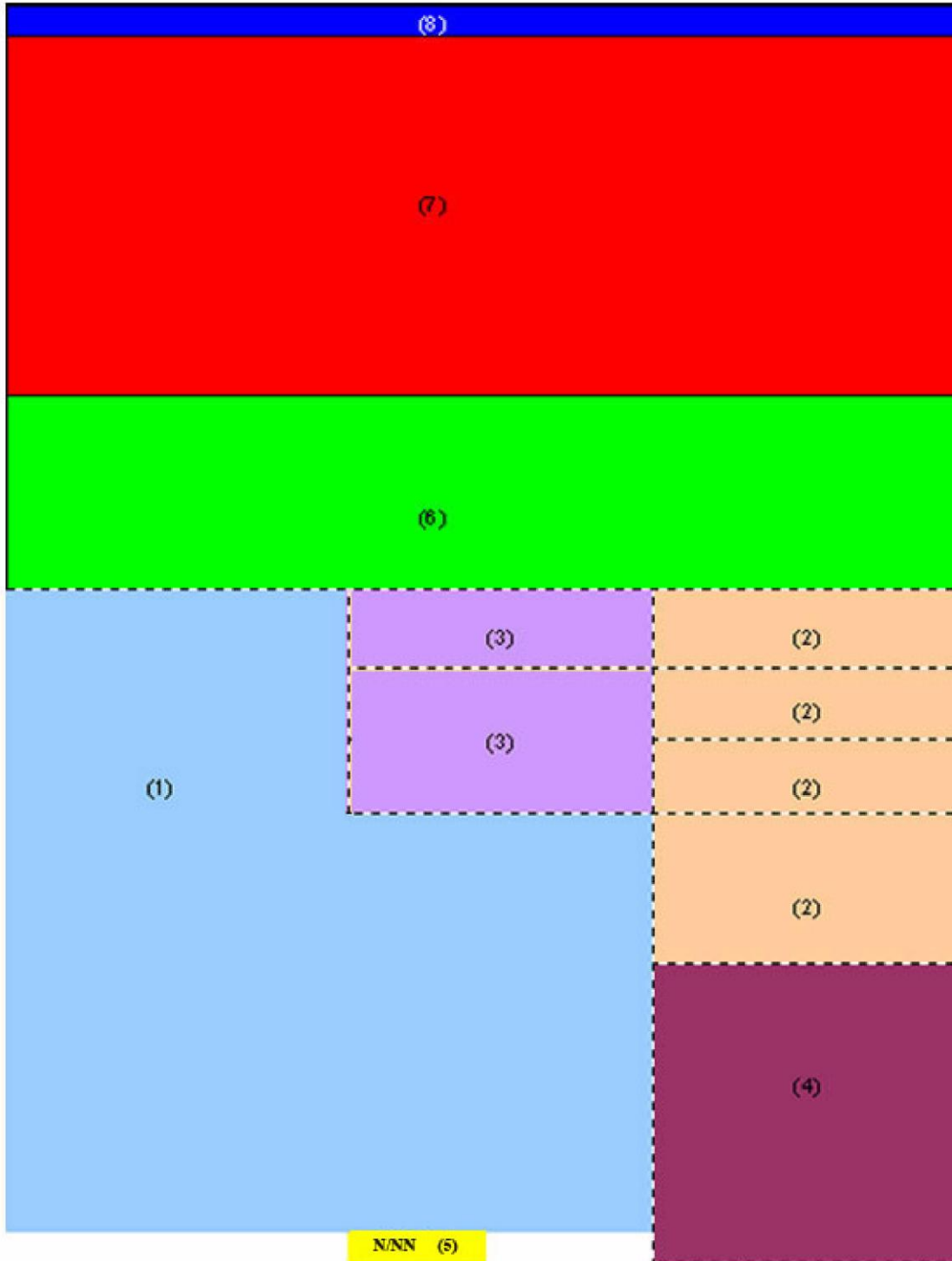

Fig. 7 - Zones of A4-printed ticket

3.2.1 - The distributor zone (8)

(size: W: min. 160 mm, H: 15 mm)

In this zone, the distributor MUST identify itself and if it wants to print a reference number for the ticket, this has to be done here. In this zone the coupon number (used for back-office purposes) is also printed.

Example:

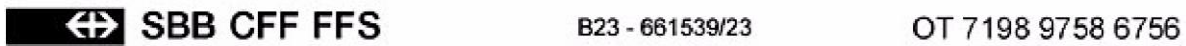

3.2.2 - The adapted RCT2 layout ("the RCT2 zone" - (7))

(size: W: min. 160 mm, H: min. 70 mm)

This zone contains all the necessary elements in a layout, recognised by the train staff of the TCO(s).

Example:

FAHRAUSWEIS / BILLET / BIGLIETTO				FISHER GEORGE 01 Erwachsene		
Gültig/Valid: 2004				31.12.1970		
30	⌚	VON/DE/DA	→ NACH/A	30	⌚	KL. CL.
24.10.	09.04	BERN	→ AMSTERDAM CS	24.10.	16.55	1
27.10.	07.05	AMSTERDAM CS	→ BERN	27.10.	16.11	*
VIA 1185-OLTEN-BASEL BAD.BF. - 1180-KARLSRUHE-WORMS O FRANKFURT (M)-KÖLN-EMMERICH GR-1184 *****						
ABT 1/2 Bahncard				CHF 272.00		
				DIN		

Fig. 8 - The adapted 9 18-2 layout - example

NB: the distributor-logo on the top-left position of this zone may only be present if it is different from the "main" distributor logo as described in point 3.2.1.

A description of the elements can be found in ERA TAP TSI Technical Document B.6, they are adapted in the following way:

- Row 4 (D): Note "Valid:" and year of departure of outward journey
- Row 16 to 18 (P to R): are dropped

2 different standards are possible:

- The basic layout:
this is a layout, based on ERA TAP TSI Technical Document B.6 and recognisable by any TCO (same as the ATB-tickets but without the security-background).

- A particular - picture based - layout (picture serving as a security background):
A distributor wishing absolutely to have a visually protected ticket, can decide to include in the bilateral agreement that the RCT2 zone is made out with this background. In that case, the layout of ERA TAP TSI Technical Document B.6, created locally on the machines of the ticket-issuer, are printed on top of a picture with the same size. As this picture is locally added by the distributor, there is no need to send this information in a message from the TCO to the distributor.

Of course, the picture must allow the reading of all necessary elements in the RCT2 zone.

Example of the basic layout:

FAHRAUSWEIS / BILLET / BIGLIETTO				FISHER GEORGE 01 Erwachsene		
Gültig/Valid: 2004				31.12.1970		
30	🕒	VON/DE/DA	→ NACH/A	30	🕒	KL. CL.
24.10.	09.04	BERN	→ AMSTERDAM CS	24.10.	16.55	1
27.10.	07.05	AMSTERDAM CS	→ BERN	27.10.	16.11	*
VIA 1185-OLTEN-BASEL BAD.BF. -1180-KARLSRUHE-WORMS O FRANKFURT (M)-KÖLN-EMMERICH GR-1184 *****						
ABT 1/2 Bahncard				CHF 272.00 DIN		

Fig. 9 - Adapted RCT2 zone - a basic ticket

3.2.3 - The reservation zone (6)

(size: W: min. 160 mm, H: variable, min. 0 mm)

If the ticket is with (a) reservation(s), then the distributor must add all the information, relative to this (the) reservation(s) in this zone.

Example:

PLATZRESERVIERUNGEN / RESERVATIONS

<i>HINFAHRT / ALLER / OUTWARD JOURNEY</i>				<i>ZUG / TRAIN</i>				<i>COACH SEAT</i>	
24.10.	09.04	BERN	-> BASEL SBB	09.59	*	*	*	*	
24.10.	10.12	BASEL SBB	-> FRANKFURT (M)	13.06	ICE	76	001	26	
24.10.	13.17	FRANKFURT (M)	-> AMSTERDAM CS	16.55	ICE	126	008	4	
<i>RÜCKFAHRT / RETOUR / RETURN JOURNEY</i>				<i>ZUG / TRAIN</i>				<i>COACH SEAT</i>	
27.10.	07.05	AMSTERDAM CS	-> FRANKFURT (M)	11.01	ICE	121	001	26	
27.10.	12.05	FRANKFURT (M)	-> BERN	16.11	ICE	73	008	4	

Fig. 10 - The reservation zone - example

Description of the elements

All elements are printed in the language of the distributor's website as well as in the second language of the contract of carriage (see point 3.1).

Row 1: Note "Reservation" if reservation info is included
 Note "Timetable" if only timetable info is included

Row 2: "Outward journey"

Row 3: Column 1: Departure date of first leg (format dd.mm)
 Column 2: Departure time of first leg (format hh.mm)
 Column 3: Departure station of first leg
 Column 4: Right arrow
 Column 5: Arrival station of first leg
 Column 6: Arrival date of first leg (format dd.mm)
 Column 7: Arrival time of first leg (format hh.mm)
 Column 8: Train type and number
 Column 9: Coach number
 Column 10: Seat number(s)

Row 3 is repeated for any subsequent leg of the outward journey. For legs without reservation (only timetable information) columns 8 to 10 are invalidated by an asterisk ("*").

If the ticket includes a "return journey", a corresponding section (row 2 and 3 ff) is added with the indication "Return journey".

3.2.4 - The certificates zones - the 2D certificate zone (2, 3, 4)

(Size of the components:

- (1) *Alphanumeric* *W: 50 mm, H: 12,5 mm*
- (2) *1D-barcode* *W: 50 mm, H: 25 mm*
- (3) *2D-barcode* *W: 50 mm, H: 50 mm)*

Basically, on a home-printed ticket, there are three different kinds of printed certificates. A certificate can be alphanumeric(1), a one-dimensional barcode(2) (= a standard barcode as used to tag goods in shops, can be replaced by a small 2D-barcode) or a two-dimensional barcode(3).

Depending on the kind of certificate, the size will be different. At the top of every certificate, there is the carrier code and a symbol, indicating if this certificate is for the outward leg, the return leg of the journey or for a round trip (→, ← or ↔) . The train staff looks for "its" certificate for the right leg and checks if the printed ticket-info is relevant.

European Railway Agency

ERA/TD/2009-10/INT: ANNEX B.7 of TAP TSI

The sizes of those certificates are:

Certificate	Height (mm)	Width (mm)
Alphanumeric	12,5	50
1 D-barcode/small 2D-barcode	25	50
2D-barcode	50	50

For technical reasons linked to the 2D barcode-reader, the big 2D-barcode must always be printed in the lower-right part of the page (if a 2D barcode is included on the ticket).



Fig. 11 - The certificates zone - example using different kinds of certificates

3.2.5 - The page number zone (5)

(size: W: min. 20 mm, H: 5 mm)

In the middle of the bottom of every page, the page number and the number of pages must be indicated.

The layout for this is XX/NN where XX is the page number and NN the number of pages.

3.2.6 - The free distributor zone (1)

(size depends on remaining space on ticket)

The distributor can add extra information (or publicity) for the client in this zone. The layout of this information, the size, the information itself may be freely chosen by the distributor.

Sample 1: Non Reservation Ticket with reservations (scaled down to fit on this page)







		OT 7198 9758 6756																												
FAHRAUSWEIS / BILLET / BIGLIETTO					FISHER GEORGE 01 Erwachsene																									
Gültig/Valid: 2004					31.12.1970																									
		VON/DE/DA	→ NACH/A			KL. CL.																								
24.10.	09.04	BERN	→ AMSTERDAM CS	24.10.	16.55	1																								
27.10.	07.05	AMSTERDAM CS	→ BERN	27.10.	16.11	*																								
VIA 1185-OLTEN-BASEL BAD,BF.--1180-KARLSRUHE-WORMS O FRANKFURT (M)-KÖLN-EMMERICH GR-1184 *****																														
ABT 1/2 Bahncard					CHF 272.00 DIN																									
PLATZRESERVIERUNGEN / RESERVATIONS / RISERVAZIONI HINFAHRT/ALLER/ANDATA 24.10. 09.04 BERN -> FRANKFURT (M) 11.53 ICE 76 001 26 24.10. 13.00 FRANKFURT (M) -> AMSTERDAM CS 16.55 ICE 126 008 4 RÜCKFAHRT/RETOUR/RITORNO 27.10. 07.05 AMSTERDAM CS -> FRANKFURT (M) 11.01 ICE 121 001 26 27.10. 12.05 FRANKFURT (M) -> BERN 16.11 ICE 73 008 4																														
Benutzungsbedingungen der Ausgabe-TU Für das Online Ticket gelten spezielle Konditionen gemäss den "Allgemeinen Geschäftsbedingungen für den Online Verkauf von Fahrausweisen und Dienstleistungen". Weitere Informationen finden Sie unter www.sbb.ch .																														
<table border="1"> <tr> <td>> 1180</td> <td>Basel SBB -> Frankfurt (M)</td> </tr> <tr> <td colspan="2">F7UI-C4TG-DTZU-5G4F</td> </tr> <tr> <td>> 1180</td> <td>Frankfurt (M) -> Emmerich</td> </tr> <tr> <td colspan="2">IKDD-2AEW-PAJ5-7DQM</td> </tr> <tr> <td>> 1184</td> <td>Emmerich -> Amsterdam CS</td> </tr> <tr> <td colspan="2"></td> </tr> <tr> <td colspan="2">TLRK-3KRK-4K3J-AODK</td> </tr> <tr> <td>< 1184</td> <td>Amsterdam CS -> Frankfurt (M)</td> </tr> <tr> <td colspan="2"></td> </tr> <tr> <td colspan="2">CDL3-RJSP-4JDK-ALCS</td> </tr> <tr> <td>< 1180</td> <td>Frankfurt (M) -> Basel SBB</td> </tr> <tr> <td colspan="2">WGZH-5Z78-F93G-2GUW</td> </tr> </table>							> 1180	Basel SBB -> Frankfurt (M)	F7UI-C4TG-DTZU-5G4F		> 1180	Frankfurt (M) -> Emmerich	IKDD-2AEW-PAJ5-7DQM		> 1184	Emmerich -> Amsterdam CS			TLRK-3KRK-4K3J-AODK		< 1184	Amsterdam CS -> Frankfurt (M)			CDL3-RJSP-4JDK-ALCS		< 1180	Frankfurt (M) -> Basel SBB	WGZH-5Z78-F93G-2GUW	
> 1180	Basel SBB -> Frankfurt (M)																													
F7UI-C4TG-DTZU-5G4F																														
> 1180	Frankfurt (M) -> Emmerich																													
IKDD-2AEW-PAJ5-7DQM																														
> 1184	Emmerich -> Amsterdam CS																													
TLRK-3KRK-4K3J-AODK																														
< 1184	Amsterdam CS -> Frankfurt (M)																													
CDL3-RJSP-4JDK-ALCS																														
< 1180	Frankfurt (M) -> Basel SBB																													
WGZH-5Z78-F93G-2GUW																														

Fig. 12 - Example of an Non Reservation Ticket with reservations

European Railway Agency

ERA/TD/2009-10/INT: ANNEX B.7 of TAP TSI

Sample 2: Integrated Reservation Ticket (scaled down to fit on this page)

				OT 7198 9758 6756		
TICKET + RESERVATION Lyria SNCF & SBB				FISHER GEORGE 04 PASSENGERS		
CIV 1185 Gültig/Valid: 2004				31.12.1970		
		VON/DE/FROM	→ NACH/A/TO			KL. CL.
24.10. *	09.04 *	BERN *	→ PARIS GARE DE LYON *	24.10 *	14.55 *	1 *
 9584		TGV COACH 002		04 SEATS :		71 72 73 74
NONSMOKING				02 WINDOW - 02 CORRIDOR		
04 PASS (44)				CARRIERS: 1185 1187		CHF 272.00 DIN

Benutzungsbedingungen der Ausgabe-TU

Für das Online Ticket gelten spezielle Konditionen gemäss den "Allgemeinen Geschäftsbedingungen für den Online Verkauf von Fahrausweisen und Dienstleistungen". Weitere Informationen finden Sie unter www.sbb.ch.

1187 Bern -> Paris Gare de Lyon
 GK34-DKWJ-2DAN-LNM1

Fig. 13 - Example of a Integrated Reservation ticket

3.3 - Type of tickets covered by this standard

In the first release of this Technical Document, only the layout of the following tickets is defined:

- Non Reservation Ticket
- Non Reservation Ticket + reservation(s)
- Non Reservation Ticket + supplement(s)
- Non Reservation Ticket + reservation(s) + supplement(s)
- Integrated Reservation Tickets

Layouts for stand-alone supplements and stand-alone reservations, as well as for other kind of transport documents, can be defined later in accordance with the Change Control Management of TAP TSI.

3.4 - Adapted RCT2 layout for the different types of ticket

3.4.1 - Non Reservation Ticket

The adapted RCT2 zone:

FAHRAUSWEIS / BILLET / TICKET				FISHER GEORGE 01 Erwachsene		
CIV 1185 Gültig/Valid: 2004				31.12.1970		
30	⌚	VON/DE/FROM	→ NACH/A/TO	30	⌚	KL. CL.
24.10.	09.04	BERN	→ AMSTERDAM CS	24.10.	16.55	1
27.10.	07.05	AMSTERDAM CS	→ BERN	27.10.	16.11	*
VIA 1185-OLTEN-BASEL BAD.BF. -1180-KARLSRUHE-WORMS O FRANKFURT (M)-KÖLN-EMMERICH GR-1184 *****						
ABT 1/2 Bahncard				CHF 272.00 DIN		

Fig. 14 - Adapted RCT2 zone of an Non Reservation Ticket

3.4.2 - Non Reservation Ticket + reservation

The adapted RCT2 zone and the reservation zone:

FAHRAUSWEIS / BILLET / TICKET				FISHER GEORGE 01 Erwachsene		
CIV 1185 Gültig/Valid: 2004				31.12.1970		
		VON/DE/FROM	→ NACH/A/TO			KL. CL.
24.10.	09.04	BERN	→ AMSTERDAM CS	24.10.	16.55	1
27.10.	07.05	AMSTERDAM CS	→ BERN	27.10.	16.11	*
VIA 1185-OLTEN-BASEL BAD.BF.-1180-KARLSRUHE-WORMS O FRANKFURT (M)-KÖLN-EMMERICH GR-1184 *****						
ABT 1/2 Bahncard				CHF 272.00 DIN		

PLATZRESERVIERUNGEN / RESERVATIONS

HINFAHRT / ALLER / OUTWARD JOURNEY

				ZUG/TRAIN COACH SEAT			
24.10.	09.04	BERN	-> BASEL SBB	09.59	*	*	* *
24.10.	10.12	BASEL SBB	-> FRANKFURT (M)	13.06	ICE	76	001 26
24.10.	13.17	FRANKFURT (M)	-> AMSTERDAM CS	16.55	ICE	126	008 4

RÜCKFAHRT / RETOUR / RETURN JOURNEY

				ZUG/TRAIN COACH SEAT			
27.10.	07.05	AMSTERDAM CS	-> FRANKFURT (M)	11.01	ICE	121	001 26
27.10.	12.05	FRANKFURT (M)	-> BERN	16.11	ICE	73	008 4

Fig. 15 - Adapted RCT2 zone and reservation zone of an Non Reservation Ticket with reservation

3.4.3 - Non Reservation Ticket + supplement

The adapted RCT2 zone:

FAHRAUSWEIS / BILLET / TICKET				FISHER GEORGE 01 Erwachsene		
CIV 1185 Gültig/Valid: 2004				31.12.1970		
		VON/DE/FROM	→ NACH/A/TO			KL. CL.
24.10.	09.04	BERN	→ AMSTERDAM CS	24.10.	16.55	1
27.10.	07.05	AMSTERDAM CS	→ BERN	27.10.	16.11	*
VIA 1185-OLTEN-BASEL BAD.BF.-1180-KARLSRUHE-WORMS O FRANKFURT (M)-KÖLN-EMMERICH GR-1184 *****						
ZUSCHLÄGE INBEGRIFFEN / SUPPLEMENTS Y COMPRIS / SUPPLEMENTS INCLUDED						
ABT 1/2 Bahncard				CHF 272.00 DIN		

Fig. 16 - Adapted RCT2 zone of an Non Reservation Ticket with a supplement

3.4.4 - Non Reservation Ticket + reservation + supplement

The adapted RCT2 zone and the reservation zone:

FAHRAUSWEIS / BILLET / TICKET				FISHER GEORGE 01 Erwachsene		
CIV 1185 Gültig/Valid: 2004				31.12.1970		
		VON/DE/FROM	→ NACH/A/TO			KL. CL.
24.10.	09.04	BERN	→ AMSTERDAM CS	24.10.	16.55	1
27.10.	07.05	AMSTERDAM CS	→ BERN	27.10.	16.11	*
VIA 1185-OLTEN-BASEL BAD.BF.-1180-KARLSRUHE-WORMS O FRANKFURT (M)-KÖLN-EMMERICH GR-1184 *****						
ZUSCHLÄGE INBEGRIFFEN / SUPPLEMENTS Y COMPRIS / SUPPLEMENTS INCLUDED						
ABT 1/2 Bahncard				CHF 272.00 DIN		

PLATZRESERVIERUNGEN / RESERVATIONS

HINFAHRT/ALLER/OUTWARD JOURNEY

				ZUG/TRAIN	COACH	SEAT
24.10.	09.04	BERN	-> BASEL SBB	09.59	*	*
24.10.	10.12	BASEL SBB	-> FRANKFURT (M)	13.06	ICE 76	001 26
24.10.	13.17	FRANKFURT (M)	-> AMSTERDAM CS	16.55	ICE 126	008 4

RÜCKFAHRT/RETOUR/RETURN JOURNEY

				ZUG/TRAIN	COACH	SEAT
27.10.	07.05	AMSTERDAM CS	-> FRANKFURT (M)	11.01	ICE 121	001 26
27.10.	12.05	FRANKFURT (M)	-> BERN	16.11	ICE 73	008 4

Fig. 17 - Adapted RCT2 layout and reservation zone of Non Reservation Ticket + reservation + supplement

3.4.5 - Integrated Reservation Ticket

TICKET + RESERVATION Lyria SNCF & SBB				FISHER GEORGE 04 PASSENGERS		
CIV 1185 Gültig/Valid: 2004				31.12.1970		
		VON/DE/FROM	→ NACH/A/TO			KL. CL.
24.10.	09.04	BERN	→ PARIS GARE DE LYON	24.10	14.55	1
*	*	*	→ *	*	*	*
	9584	TGV	COACH 002	04 SEATS :	71 72 73 74	
NONSMOKING				02 WINDOW - 02 CORRIDOR		
04 PASS (44)				CARRIERS: 1185 1187		CHF 272.00 DIN

Fig. 18 - Adapted RCT2 layout of a integrated reservation ticket

NB: These examples were created in a "basic layout" (see point 3.2.2). If the bilateral agreement mentions that the layout should be picture-based, then this part of the ticket can be completely different.

4 - The certificates

The TCOs create the different certificates. The distributor sends the TCO the data needed to generate and deliver the certificate. This procedure is used in CMC and CKC (see List of abbreviations) environments (see points 4.1 and 4.2). An exception is possible, when the distributor works autonomously, it is explained in the DST-description (see point 4.3).

Three mechanisms are possible:

4.1 - "Carrier Makes Certificate - CMC"

The distributor sends client and ticket information to the TCO (or another company working on assignment for the TCO - this company may be the distributor itself working as a subcontractor for the TCO). The TCO calculates a certificate allowing the TCO itself to check, when controlling the ticket, whether the content of the ticket has not been changed.

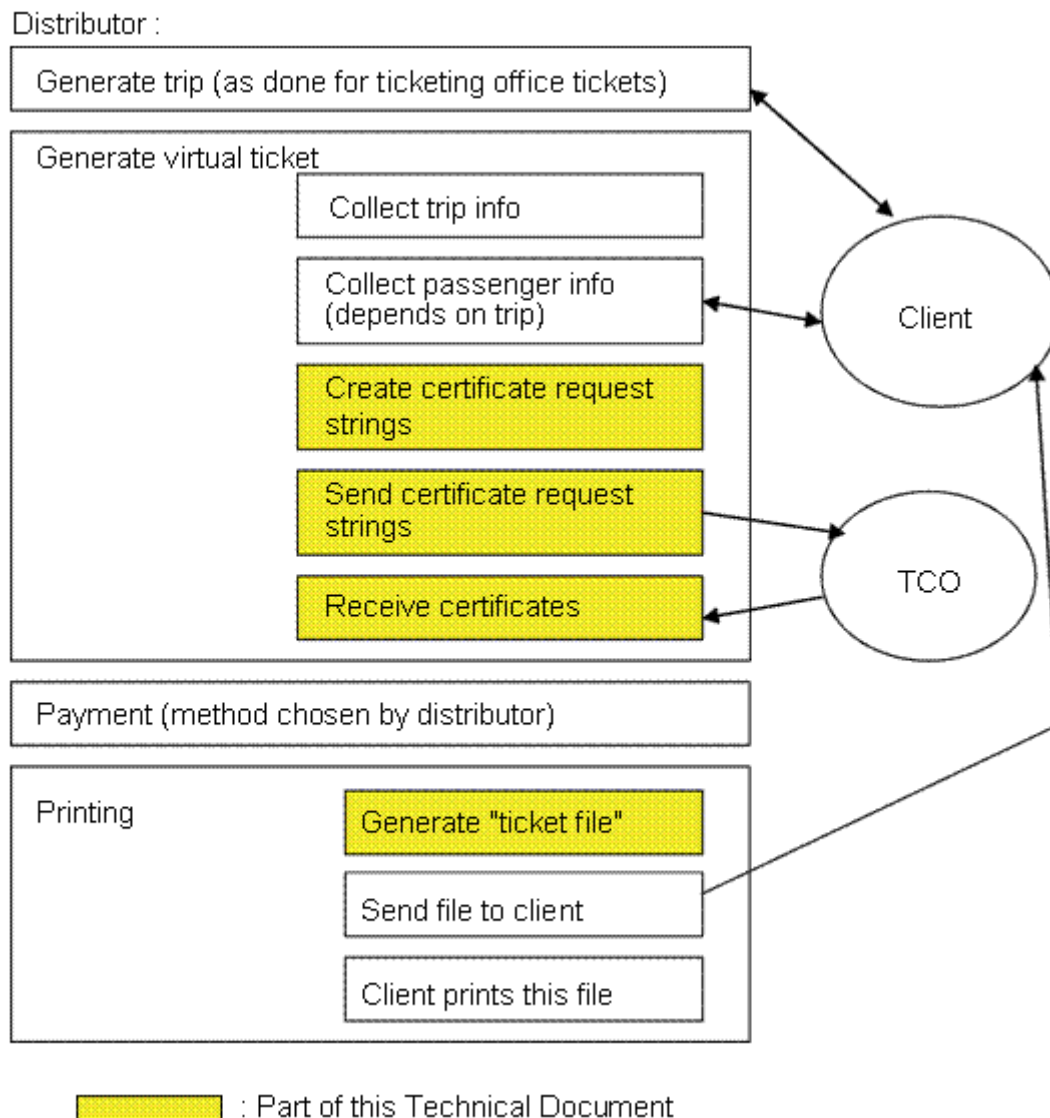

Fig. 19 - CMC standardisation

4.2 - "Carrier keeps contract - CKC"

The distributor sends client and ticket information to the TCO (or another company working in assignment for the TCO). The TCO creates a complete travel file and saves it on its server(s). The distributor receives the reference number of the file and uses it as a certificate. The TCO can control the client by looking on its server for the information that goes with the reference number. The control consists in verifying whether this information matches with the client and his/her journey. For the distributor this system is transparent and identical to the CMC procedure.

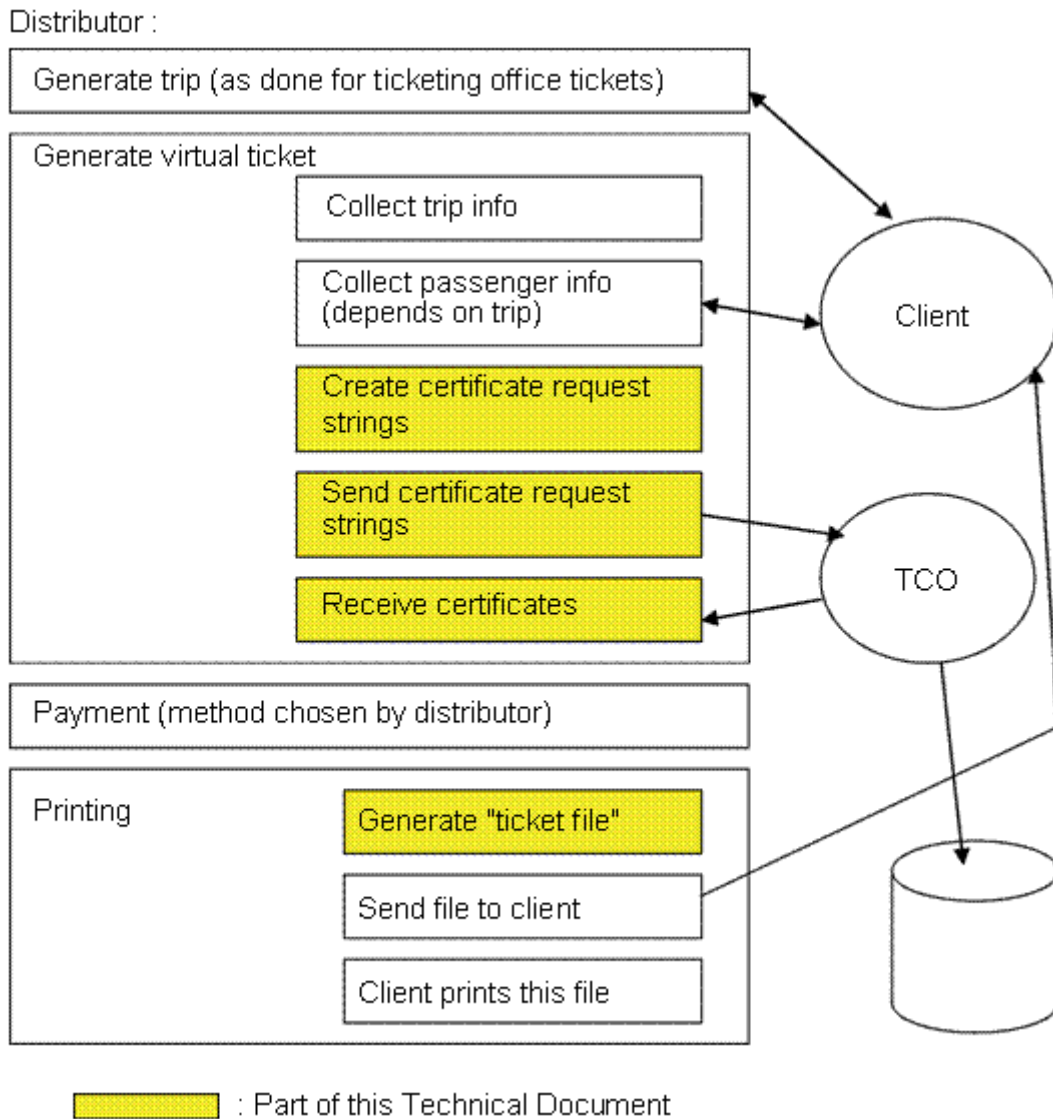

Fig. 20 - CKC standardisation

4.3 - Digitally Signed Ticket (DST)

As in point 4.1, but the distributor and the TCO use an asymmetrical algorithm to calculate the certificate, so that the distributor can create a certificate autonomously. This Technical Document - point 8 describes the algorithm completely, apart from the key pairs that must be defined for each agreement. This method has the advantage that the algorithm works on every system (the efficiency has been studied a priori) and that an algorithm has to be programmed only once and will work with any TCO. In case the bilateral agreement enables this system (DST), the TCO and the distributor only have to describe the key pairs and the mechanism and frequency for exchanging them.

The mechanism of exchanging the keys is also part of the bilateral agreement.

As the generation of the certificates is done locally, the data flow is as follows:

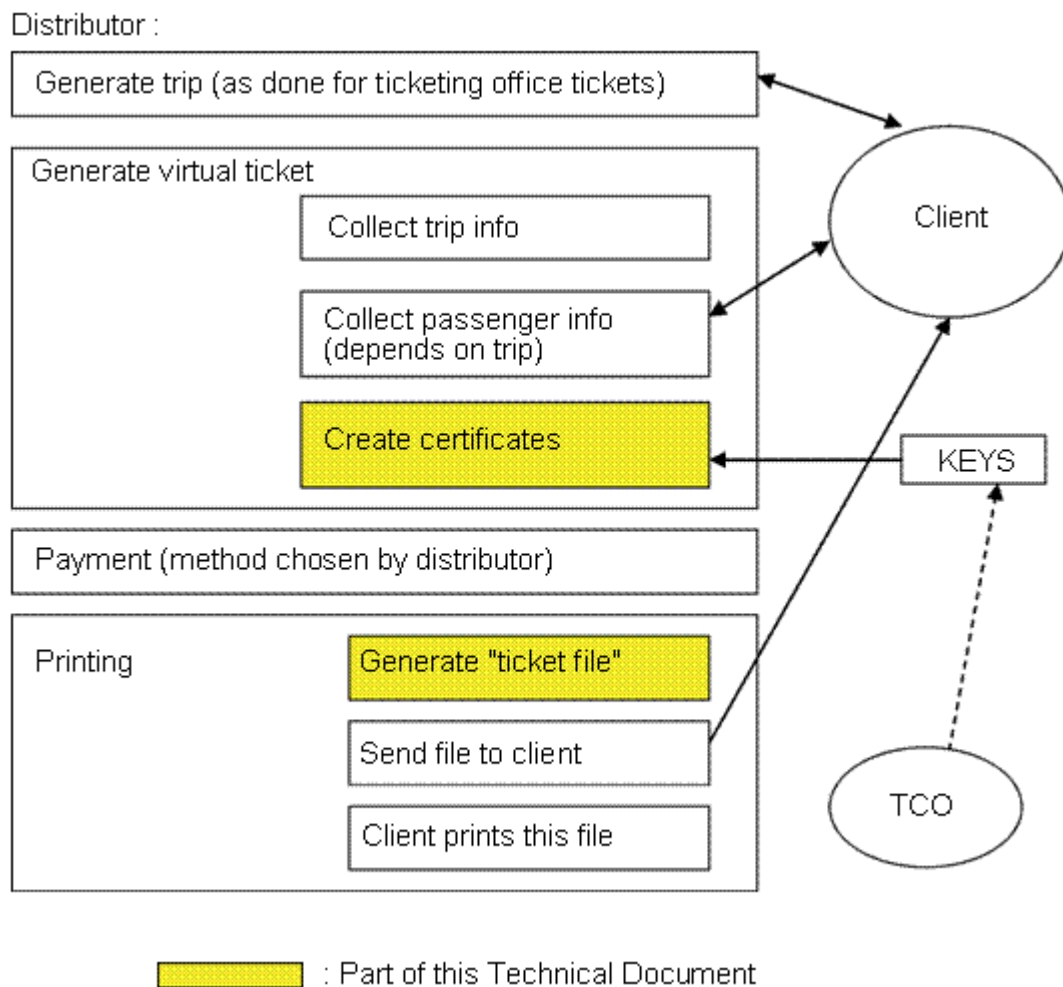

Fig. 21 - DST standardisation

4.4 - Combinations

Of course, combinations of two or three of the above described mechanisms are possible. The distributor has to know (by the bilateral agreements) which mechanism is applied with each TCO.

4.5 - Layout of the certificate zones

As mentioned, three different kinds of certificates are possible:

- an alphanumeric certificate,
- a one-dimensional barcode,
- a 2D-barcode.

The 2D-barcode will be printed on the bottom-right zone of the ticket and will not be preceded by any other text.

The 1 D-barcode or alphanumeric kind of certificates will be printed in two lines:

d (2) – a (4) – b (17) – c (17)
e (20)

where:

- d (2) : arrow, indicating direction (>, < or <>)
- a (4) : TCO-code (carrier code)
- b (17) : boarding station name for this segment (alphanumeric code according to ERA TAP TSI Technical Document B.9)
- c (17) : destination station name for this segment (alphanumeric code according to ERA TAP TSI Technical Document B.9)
- e (20) : certificate (alphanumeric or barcode)

In case of a 1 D barcode, the info of the barcode is printed just below in alphanumeric layout too (to be used in case of a problem while reading the barcode).

4.6 - Checking of the certificates

The train staff of each TCO will check the certificate specific to that TCO. The on-board personnel will "decrypt" the information found in the zone as it was created by the TCO and recognise the zone using the carrier code number (zone "a" in point 4.5).

5 - Security services (CMC, CKC)

5.1 - Mechanism

The first and second methods (CMC, CKC) require a transfer of information from the distributor to the TCO to ensure that the required data are available for the issuing of the certificate. This action must be repeated for each TCO.

There are two types of information:

- references of the passenger(s), and
- references of the journey.

Each TCO has to send a certificate as an answer to this certificate request string. The certificate contains a maximum of 200 characters and must be presented in the form of a text (and optionally as a bar-code).

All the data that may be communicated between the distributor and the TCO are listed in point 5.2.2. Obviously not all these data must be used to generate the certificate. The bilateral agreement will specify the data the TCO needs to issue the certificates.

5.2 - Certificate request string

5.2.1 - Layout of the certificate request string

Schema TAP_TSI_B.7_v1.1.1.xsd is available on the ERA Website.

The following definition applies for all types of tickets - Non Reservation Tickets and train connected tickets, even a combination is possible.

The different fields that should be used to create CR-messages are:

- General fields (G)
- Passenger fields (P)
- Non Reservation Tickets fields (O)
- Reservation fields (R)

A message must always contain exactly one G, at least one P and may contain several O and/or R.

For example:

- one passenger, making one-way trip with a integrated reservation mandatory train:
G + P + R
- group with 3 passengers making a journey consisting of one non integrated reservation section and two sections where reservation is mandatory:
G + (P + O + R + R) + (P + O + R + R) + (P + O + R + R).

The first group (P + O + R + R) contains the journey-info (including the exact reservation info and the reduction info for this client on these trains) for the first member of the group.

The second and the third series of data hold the info for the second and third traveller.

5.2.2 - General fields

Number in sequence	Element	Number of characters	Mandatory	Code	Num/ Alpha	Comments
1	Message type	2	X	X	A	"CR" (certificate request)
2	Distributor-ID part of Certificate Request ID (distributor) (distributor reference part 1/2)	4	X	X	N	Code that refers to the distributor (as in ERA TAP TSI T. D. B.8)
3	Reference part of Certificate Request ID (distributor) (distributor reference part 2/2)	16	X		A	e.g. Order number / Other reference / Online Code
4	Family name of client	20			A	First 20 characters of family name
5	Given name of client	20			A	First 20 characters of given name
6	Client identification number	20			A	ID, credit card
7	Client identification type	4		X	A	Type of card. A list of the different cards is found in Code List B.7.1
8	Number of travellers	2	X		N	
9	Birth date	8			N	DDMMYYYY
10	Class	1	X	X	A	following ERA TAP TSI T. D. B.5 <i>element 24</i>
11	Single or return journey	1	X	X	A	"0": single journey "1 ": return journey

NB:

- Elements 2 and 3:
This is the reference number of the distributor. The answer of the TCO will refer to this number. This element is not only for runtime, but also for after sale operations on the database (clearing...).
- Elements 4 and 5:
The client is the person whose identity can be used to generate the certificate. For example, if credit card information is used in the certificate generation algorithm, it must be the data of this person.

- Element 6:
Several systems for calculating the certificates are linked to (credit) card numbers. This is the card the traveller will use during his/her journey to identify him-/herself and not necessarily the card he/she used to pay for his/her journey.
- Element 10:
According to ERA TAP TSI Technical Document B.5, the class may also be indicated using a letter.

5.2.3 - Passenger fields

The following 3 elements describe the passengers. For each passenger the elements are repeated.

Number in sequence	Element	Number of characters	Mandatory	Code	Num/Alpha	Comments
1	Sequence number of the traveller	2	X		N	
2	Type of passenger	5	X	X	N	according to ERA Code List B.4.5261
3	Reduction for this passenger	6	X	X	A	According to ERA Code List B.4.5263

5.2.4 - Non Reservation Tickets fields

The following definition is added to the passenger part (see point 5.2.3) for Non Reservation Tickets. In case of a round trip ticket it appears twice:

- first instance for the outbound journey, and
- second instance for the return part of the journey.

ID Number in sentence	Element	Number of characters	Mandatory	Code	Num/Alpha	Comments
<i>The following elements describe the legs of the route. For each leg the elements are repeated.</i>						
1	Sequence number of leg	2	X		N	
2a	Boarding station	7	X	X	N	According to ERA TAP TSI T. D. B.5 <i>element 22A</i>
2b	Boarding station	AAA	X	X	A	H2H-code (see abbreviation list)
3a	Destination station	7	X	X	N	According to ERA TAP TSI T. D. B.5 <i>element 22B</i>
3b	Destination station	AAA	X	X	A	H2H-code
4	Supplement	1	X	X	A	"0": not included "1": included
5a	Tariff	9		X	N	According to ERA TAP TSI T. D. B.5 <i>element 42</i>
5b	Tariff code	BBB		X	A	H2H-code
6	Reduction %	2			N	
7	Date	8	X		A	DDMMYYYY
8	Last day of validity	8	X		A	DDMMYYYY

NB : 2a/2b, 3a/3b, 5a/5b can be chosen - must be described in the bilateral agreement
AAA/BBB will be defined in the bilateral agreement (if H2H-codes are used).

5.2.5 - Reservation fields

The following definition is added to the passenger part (see point 5.2.3) for Non Reservation Tickets with reservation or for Integrated Reservation tickets. In case of a round trip ticket it appears twice:

- first instance for the outbound, and
- second instance for the return part of the journey.

ID Number In sentence	Element	Number of characters	Mandatory	Code	Num/ Alpha	Comments
<i>The following elements describe the trains used. For each train the elements are repeated.</i>						
1	Sequence number of train	2	X		N	
2	Former reference number	10			A	TCO, e.g. PNR
3	Train number	5	X	X	A	According to ERA TAP TSI T. D. B.5 <i>element 20A</i>
4	Coach number	3			A	According to ERA TAP TSI T. D. B.5 <i>element 27</i>
5	Seat number	3			A	According to ERA TAP TSI T. D. B.5 <i>element 28</i>
6a	Boarding station	7	X	X	N	According to ERA TAP TSI T. D. B.5 <i>element 22A</i>
6b	Boarding station	AAA	X	X	A	H2H-code
7a	Destination station	7	X	X	N	According to ERA TAP TSI T. D. B.5 <i>element 22B</i>
7b	Destination station	AAA	X	X	A	H2H-code
8	Supplement	1	X	X	A	"0": not included "1 ": included
9a	Tariff	9		X	A	According to ERA TAP TSI T. D. B.5 <i>element 42</i>
9b	Tariff code	BBB		X	A	H2H-code
10	Reduction %	2			A	
11	Date	8	X		A	DDMMYYYY
12	Last validity date	8	X		A	DDMMYYYY

- NB :**
- 6a/6b, 7a/7b, 9a/9b can be chosen - must be described in the bilateral agreement
 - AAA/BBB will be defined in the bilateral agreement (if H2H-codes are used)
 - "Former reference number":

When the file is linked to a former demand (i.e. the reservation in the inventory system of the TCO or one of its partners) the file number of the request must be added.

5.3 - Certificate generation

This information, namely the completed fields (as described in the bilateral agreement), allows the TCO to generate its certificate. The TCO is free to use its own method to generate this certificate. The TCO generates it and controls it afterwards in the train. The formula it uses to make a character-based certificate is its own and must not be shared. The max. size of the character string is defined in the layout of the CT-message in point 5.4. The TCO can decide how this character-based certificate should be presented on the home-printed ticket (alphanumeric, 1D-barcode (+ what standard to use), 2D-barcode or other presentation).

5.4 - Certificate transfer

Schema TAP_TSI_B.7_v1.1.1.xsd is available on the ERA website.

In return the TCO sends the following data.

Number in sequence	Element	Number of characters	Mandatory	Code	Num/Alpha	Comments
1	Message type	2	X	X	A	ID is "CT" (certificate transfer)
2	Certificate Request ID (distributor)	20	X		N	2 parts: Distributor-ID part (4) and reference part (16) - see general fields description point 5.2.2
3	TCO transaction ID	20	X		N	2 parts: TCO-ID part (4) and reference part (16) - as in general fields description in point 5.2.2
4	Error code	2	X	X	N	See Appendix B
<i>The following 8 elements are repeated for each train (i= index of text field).</i>						
5 + 8i	Sequence number of the train	2	X		N	
6 + 8i	Boarding station segment	7	X		N	According to ERA TAP TSI T. D. B.5 element 22A
7 + 8i	Destination station segment	7	X		N	According to ERA TAP TSI T. D. B.5 element 22B
8 + 8i	TCO code	4	X	X	A	According to ERA TAP TSI T. D. B.5 element 78

European Railway Agency

ERA/TD/2009-10/INT: ANNEX B.7 of TAP TSI

Number in sequence	Element	Number of characters	Mandatory	Code	Num/Alpha	Comments
9 + 8i	Client identification number	20			A	e.g. some digits of number of credit card or ID-card or loyalty-card used to verify the certificate. The cardholder must be the traveller, responsible for the group (see point 1) (the card is not necessarily the card, used to buy the ticket)
10 + 8i	Client identification type	4		X	A	Type of card used to verify the certificate. A list of the different cards is found in ERA Code List B.7.1 See also remark above about "traveller, responsible of the group"
11 + 8i	The way the string should be presented	6	X	X	A	See Code List B.7.2
12 + 8i	The actual security-string (the "certificate")	200	X		A	Size depends on presentation

NB : If "Error Code" is not "00", then subsequent elements (5 etc.) are replaced by the following:

5	Error message	100				Description of the actual error (for development and testing phase)
---	---------------	-----	--	--	--	---

5.5 - Important remark about list of TCOs per train - multiple TCO's/segment

It is possible that the TCO is different from the carrier. For example, some German ICE-trains going to the Netherlands have Dutch control staff on board. This means that the NS has to be added on the list of the TCOs in case of a home-printed ticket for this train so that they can generate a certificate that will be printed on the ticket.

For the Distributor it is quite impossible to know all the TCOs per train for every possible carrier. The carrier itself knows all the TCOs that can be working on its specific trains.

The distributor will ask the carrier (logically the first TCO involved) to generate a certificate and if the carrier knows that one or more supplementary TCO(s) will have to generate also a certificate, than the carrier itself will send a demand for certificate to the other TCO(s). They will answer the carrier (the first TCO) by sending their certificates for this journey. The carrier will send to the distributor not only the certificate it generated, but also the certificates it received from the other TCO(s).

The demand of the carrier addressed at other TCOs is following the same mechanism as the demand from a distributor to a TCO. The carrier sends a Certificate Request message to a TCO and the TCO sends a Certificate Transfer message as an answer to the carrier.

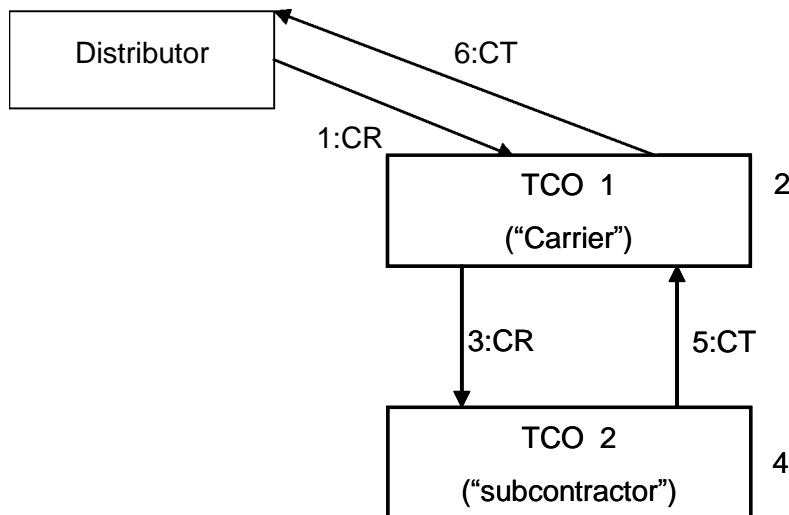

- Step 1: Distributor contacts the carrier ("TCO1 ")
- Step 2: TCO1 creates a certificate and contacts, based on the train list, TCO2
- Step 3: TCO1 sends to TCO2 a Certificate Request
- Step 4: TCO2 creates its certificate
- Step 5: TCO2 sends its certificate to TCO1
- Step 6: TCO1 sends its certificate and the certificate it received from TCO2 in one CT-message to the distributor who sent the initial CR.

Fig. 22 - More than one TCO for one segment

5.6 - Cancellation message

Schema TAP_TSI_B.7_v1.1.1.xsd is available on the ERA website.

A cancellation message can be generated by the distributor in four different cases:

1. the CR message did not result in a CT message in time;
2. the CR message was resulting in a CT but another TCO did not answer appropriately;
3. the CR message resulted in a CT message but the client did not go till the end (payment, printing, ...) so the generated certificate will not be used and must be cancelled;
4. in case of a closed system (i.e. a system where after sales operations information is going back to the distributor and all concerned TCOs. This kind of system allows cancellation of tickets, since travelling with a copy of the original ticket will be detected), the printed and payed ticket is exchanged or cancelled. The cancellation message is to inform the TCO that this ticket is no longer valid.

Number in sequence	Element	Number of characters	Mandatory	Code	Num/ Alpha	Comments
1	Message type	2	X	X	A	ID is "CM" (cancellation message)
2	Reference ID of cancellation	20	X		N	2 parts: Distributor-ID part (4) and reference part (16) - see general fields description in point 5.2.2
3	Record number	5	X		N	Sequence number
4	Certificate request ID (distributor)	20	X		N	2 parts: Distributor-ID part (4) and reference part (16) -see remark about record 2
5	TCO transaction ID	20			N	2 parts: TCO-ID part (4) and reference part (16) - see general fields description in point 5.2
6	Cancellation reason	20		X	A	Reason of cancellation - see Code List B.7.3

a. only if the distributor received an answer from the TCO.

5.7 - Cancellation acknowledgement

Schema TAP_TSI_B.7_v1.1.1.xsd is available on the ERA Website.

Number in sequence	Element	Number of characters	Mandatory	Code	Num/Alpha	Comments
1	Message type	2	X	X	A	ID is "CA" (cancellation acknowledgement)
2	Cancellation reference ID (distributor)	20	X		N	2 parts: Distributor-ID part (4) and reference part (16) - see general fields in point 5.2
3	Ack error	200	X		A	No error: Blank Error: Message (e.g. client trying to cancel twice)

6 - Class diagrams of the different messages

6.1 - Overview of the messages

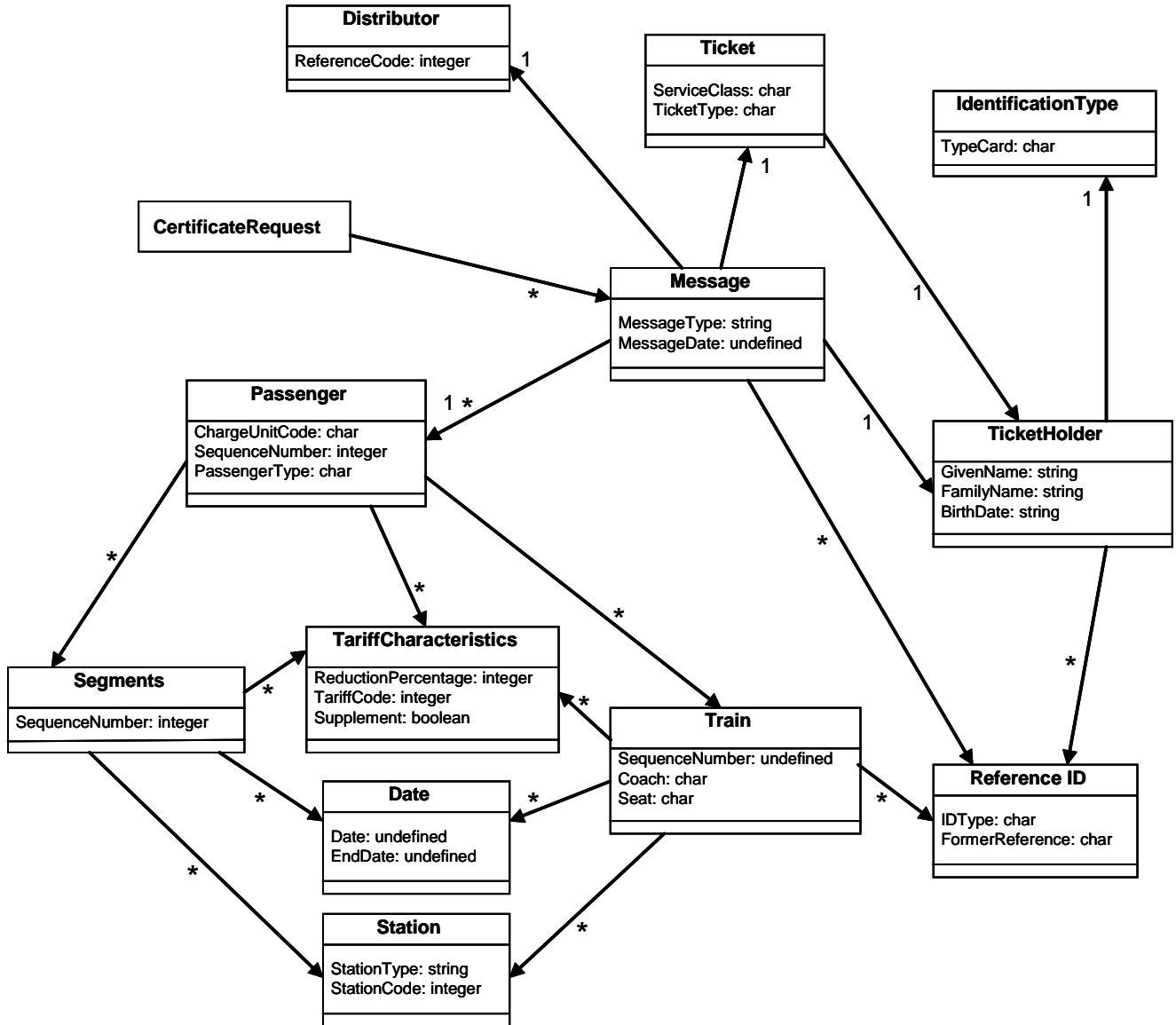

Fig.23 - Class diagram: Certificate Request_Message

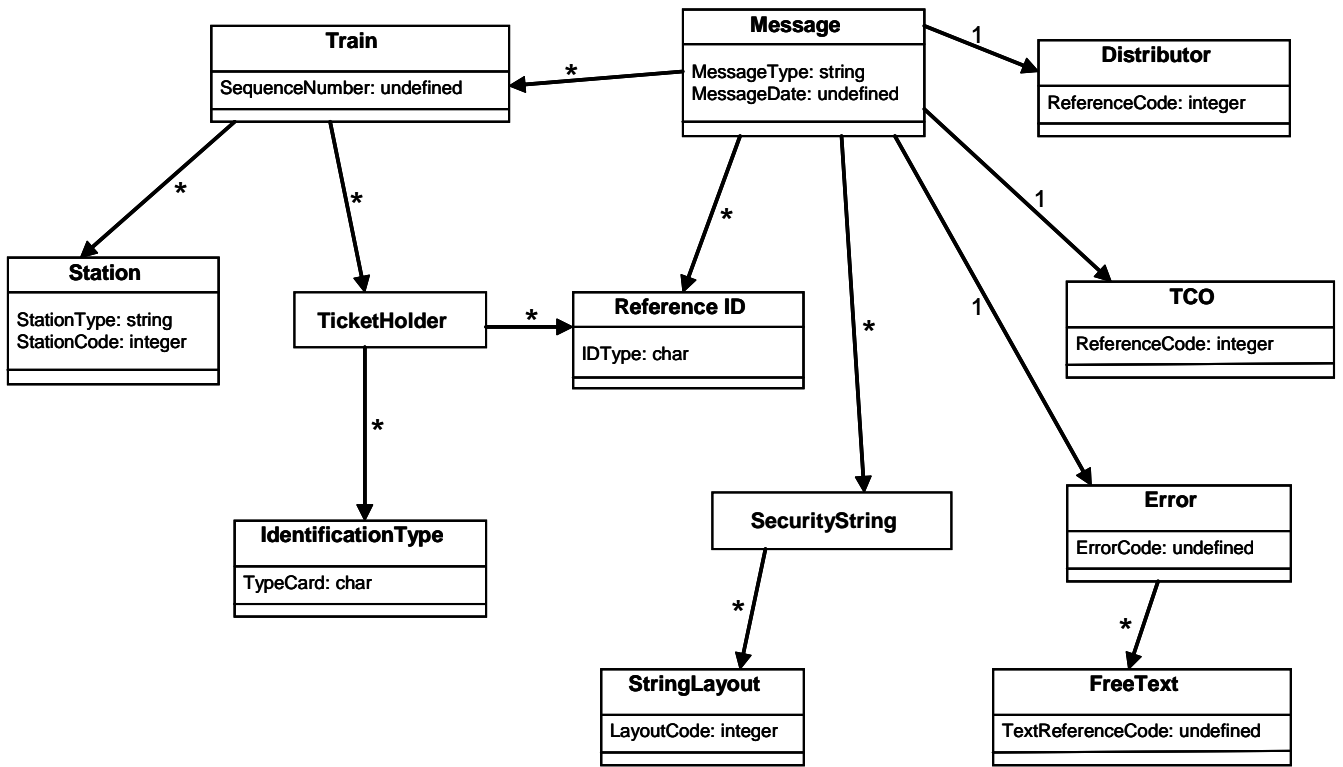

Fig. 24 - Class diagram: Certificate Transfer_Message

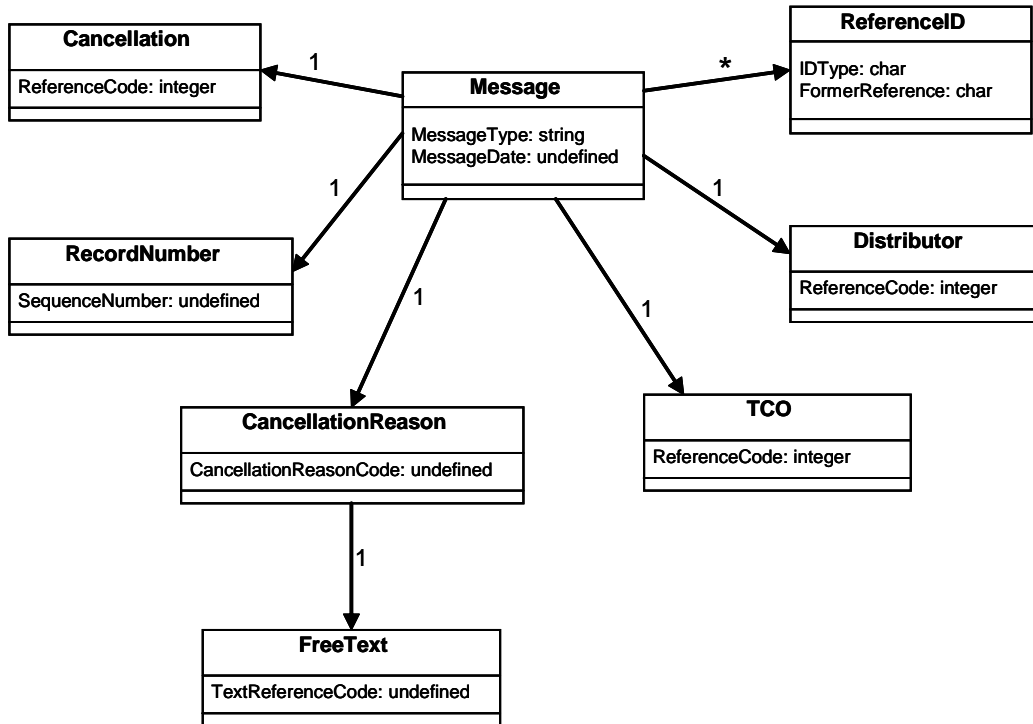

Fig. 25 - Class diagram: Cancellation_Message

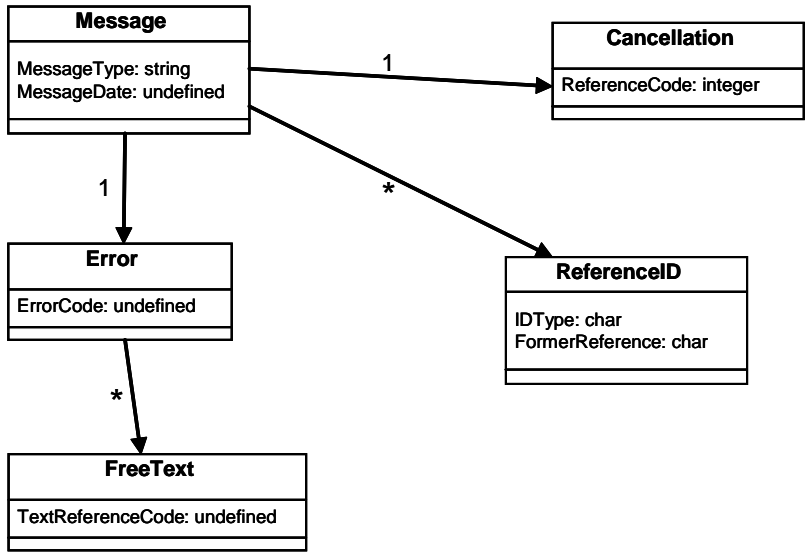

Fig. 26 - Class diagram: Cancellation Acknowledgement_Message

6.2 - Detailed specification of the classes

6.2.1 - "Message" class

It contains the following associations:

- Distributor,
- ReferenceID,
- Segments,
- Train,
- Error,
- Passenger,
- TicketHolder,
- Ticket,
- Train,
- TCO,
- SecurityString,
- CancellationReason,
- ReferenceID,
- Cancellation,
- RecordNumber

It contains the following attributes:

- MessageType,
- MessageDate.

6.2.2 - "Distributor" class

An undertaking providing to an issuer the legal and technical capacity to sell rail products to a customer, or providing directly to the customer the legal and technical capacity to buy rail products.

It contains the following attributes:

- Reference Code : Distributor identification; Limited to 4 positions.

6.2.3 - "Supplement" class

Yes/No condition if supplement applies to journey.

It contains the following attributes:

- SupplementApplied.

6.2.4 - "Station" class [harmonize with TAP Glossary?]

Station identification

It contains the following attributes:

- StationType: Boarding Station, Destination Station,
- Station Code.

6.2.5 - "Segments" class

Description of segments of journey.

It contains the following associations:

- Supplement,
- Station,
- TariffCharacteristics,
- Ticket,
- Station,
- TariffCharacteristics,
- Date

It contains the following attributes:

- SequenceNumber

6.2.6 - "ReferenceID" class

If used to indicate a Certificate Request ID, it refers to the reference number of the distributor; the answer of the TCO will refer to this number. In order to ensure the uniqueness of the number, it is associated with the 4-digit code of the distributor. This request ID allows the distributor to make a distinction when the answers of the different TCOs arrive at the different moments. This element is not only runtime, but also for after sale operations on the database.

May also be used to indicate the identification reference of a ticket holder (Credit Card, Bahn Card, etc.).

It contains the following attributes:

- IDType: describes the Type of Identification reference (i.e. Credit Card, Bahn Card, etc.). Will use enumerated values
- FormerReference.

6.2.7 - "TariffCharacteristics" class

Provides details on the tariff.

It contains the following attributes:

- ReductionPercentage,
- TariffCode,
- Supplement.

6.2.8 - "Ticket" class

Provides details related to Ticket.

It contains the following associations:

- TicketHolder.

It contains the following attributes:

- TicketType: one way = 1; round trip = 2,
- EndDate: used only for Non Reservation Ticket. Expressed as YYMMDD,
- ServiceClass: Class of service according to Code List B.7.7,
- Date: Expressed as YYMMDD.

6.2.9 - "TicketHolder" class

Client name and identification.

It contains the following associations:

- ReferenceID,
- Passenger,
- IdentificationType,
- ReferenceID,
- IdentificationType.

It contains the following attributes:

- GivenName: First 20 Characters of the Client's Given Name. Harmonised with UNTDED and ISO Directory,
- FamilyName: Client's Family Name limited to 20 Characters. Harmonised with UNTDED and ISO directories,
- BirthDate.

6.2.10 - "Passenger" class

Details of passengers included on a ticket.

It contains the following associations:

- TariffCharacteristics,
- Train,
- Segments.

It contains the following attributes:

- ChargeUnitCode: Type of Passenger (Code List B.7.4);
- SequenceNumber: Sequence number for Passenger;
- PassengerType.

6.2.11 - "Train" class

It contains the following associations:

- Supplement,
- Station,
- Ticket,
- ReferenceID,
- TariffCharacteristics,
- ReferenceID,
- Date,
- Station,
- TicketHolder.

It contains the following attributes:

- SequenceNumber,
- Coach,
- Seat.

6.2.12 - "Error" class

It contains the following associations:

- FreeText.

It contains the following attributes:

- ErrorCode: see Code List B.7.5.

6.2.13 - "FreeText" class

It contains the following attributes:

- TextReferenceCode,
- Reservation: 0 = No; 1 = Yes.

6.2.14 - "IdentificationType" class

It contains the following attributes:

- TypeCard.

6.2.15 - "Date" class

It contains the following attributes:

- Date,
- EndDate.

6.2.16 - "TCO" class

It contains the following attributes:

- ReferenceCode.

6.2.17 - "SecurityString" class

It contains the following associations:

- StringLayout.

6.2.18 - "StringLayout" class

It contains the following attributes:

- LayoutCode.

6.2.19 - "CancellationReason" class

It contains the following associations:

- FreeText.

It contains the following attributes:

- CancellationReasonCode.

6.2.20 - "Cancellation" class

It contains the following attributes:

- ReferenceCode.

6.2.21 - "RecordNumber" class

It contains the following attributes:

- SequenceNumber.

6.2.22 - "CertificateRequest" class

It contains the following associations:

- Message.

6.3 - Use cases

6.3.1 - Description

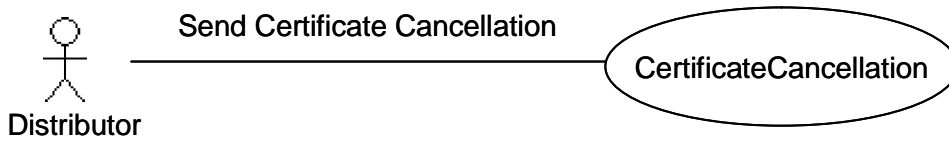

Fig. 27 - Use case diagram: (Analysis) - DistributorSendCertificateCancellation

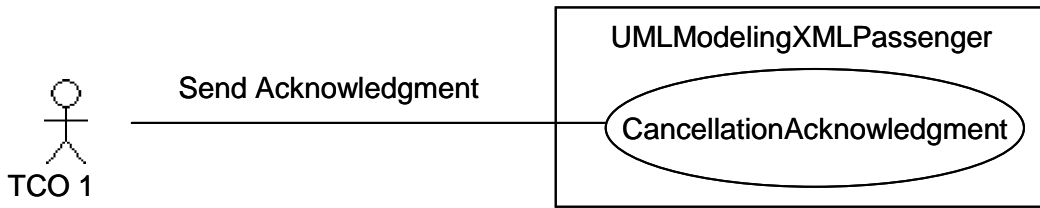

Fig. 28 - Use case diagram: (Analysis) - TCO SendCancellationAcknowledgment

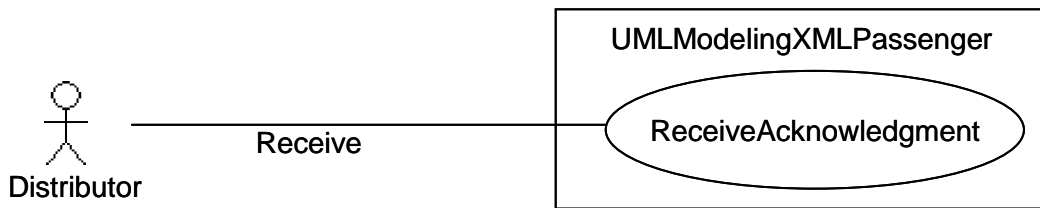

Fig. 29 - Use case diagram: (Analysis) - DistributorReceiveAcknowledgment

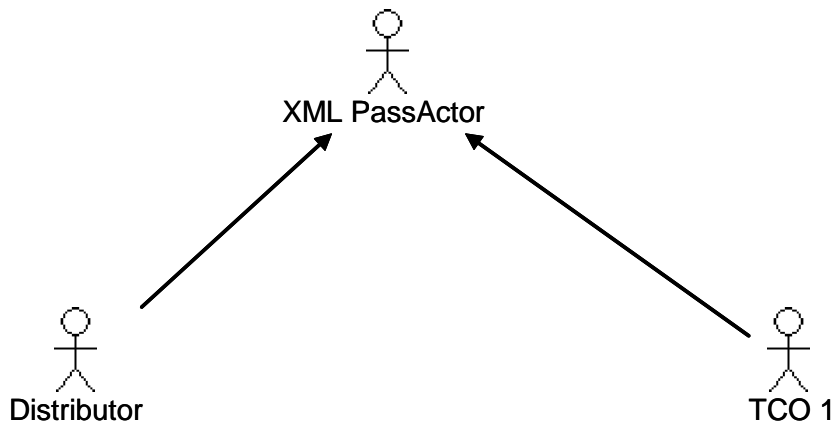

Fig. 30 - Use case diagram: (Analysis) - Actors

The actors concerned are:

- distributor_,
- TCO 1,
- XML_PassActor.

The defined use cases are:

- CertificateCancellation,
- CancellationAcknowledgment,
- ReceiveAcknowledgment.

6.3.2 - "Distributor_" actor

It specializes the actor XML_PassActor.

It cooperates with the following use cases:

- CertificateCancellation,
- ReceiveAcknowledgment.

6.3.3 - "TCO 1" actor

It specifies the actor XML_PassActor.

It cooperates with the following use cases:

- CancellationAcknowledgment.

6.3.4 - "CertificateCancellation" use case

The cooperating actors are:

- Distributor_.

6.3.5 - "CancellationAcknowledgment" use case

The cooperating actors are:

- TCO 1.

6.3.6 - "ReceiveAcknowledgment" use case

The cooperating actors are:

- Distributor_.

7 - Messaging process + exceptions in messaging (CMC, CKC)

7.1 - Sequence in messaging

Possible answers that every TCO gives to the distributor after receiving the certificate request string-message:

- no answer (time-out),
- error code = 00 + certificate (string),
- error code <> 00 + error message (see Appendix B).

The TCO has only one chance to send the certificates or the error messages. Within x seconds after receiving the request to generate the certificate, the TCO has to return an answer (the time limit will be contractually fixed in the Service Level Agreement between the distributor and the TCO). The distributor will cancel the sale if it didn't receive a message within the fixed time limit. If a sale is cancelled, all certificates of the different TCO's, linked to this ticket, will be cancelled.

A cancellation message (sent from a distributor to a TCO) always results in a cancellation acknowledgement (going from the TCO to the distributor who sent the cancellation message).

If the distributor did not receive the cancellation acknowledgement message in time, it will retry max. 2 times immediately. If no cancellation acknowledgement comes in, even after 2 retries, the procedure of sending a cancellation message will start again every two hours until a cancellation acknowledgement is received. If no answer comes in after 3 days, the cancellation request messages will no longer be sent.

7.2 - Messaging sequence diagrams

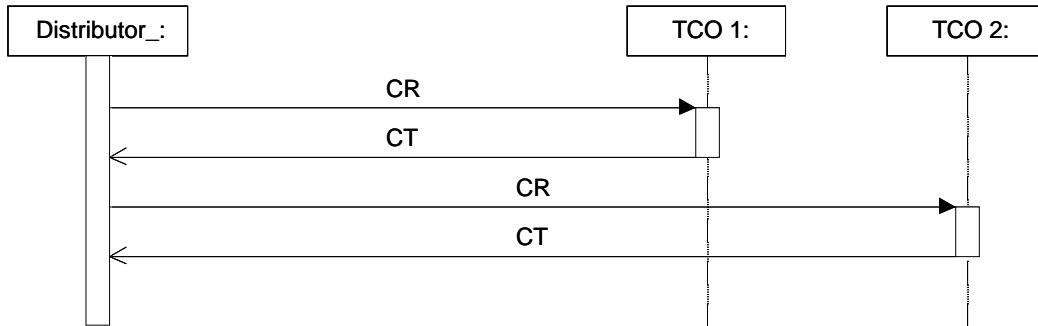

Fig. 31 - The normal sequence - 2 TCOs

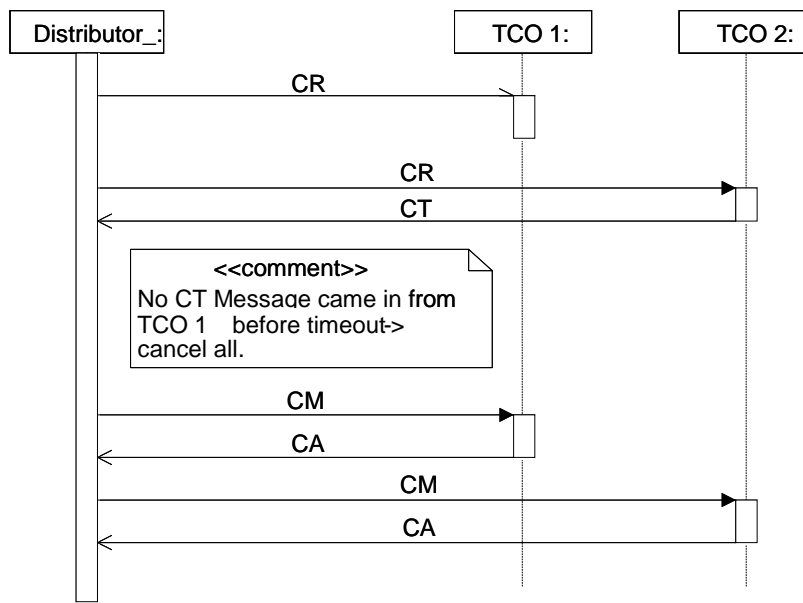

Fig. 32 - Special case 1: no answer from TCO1

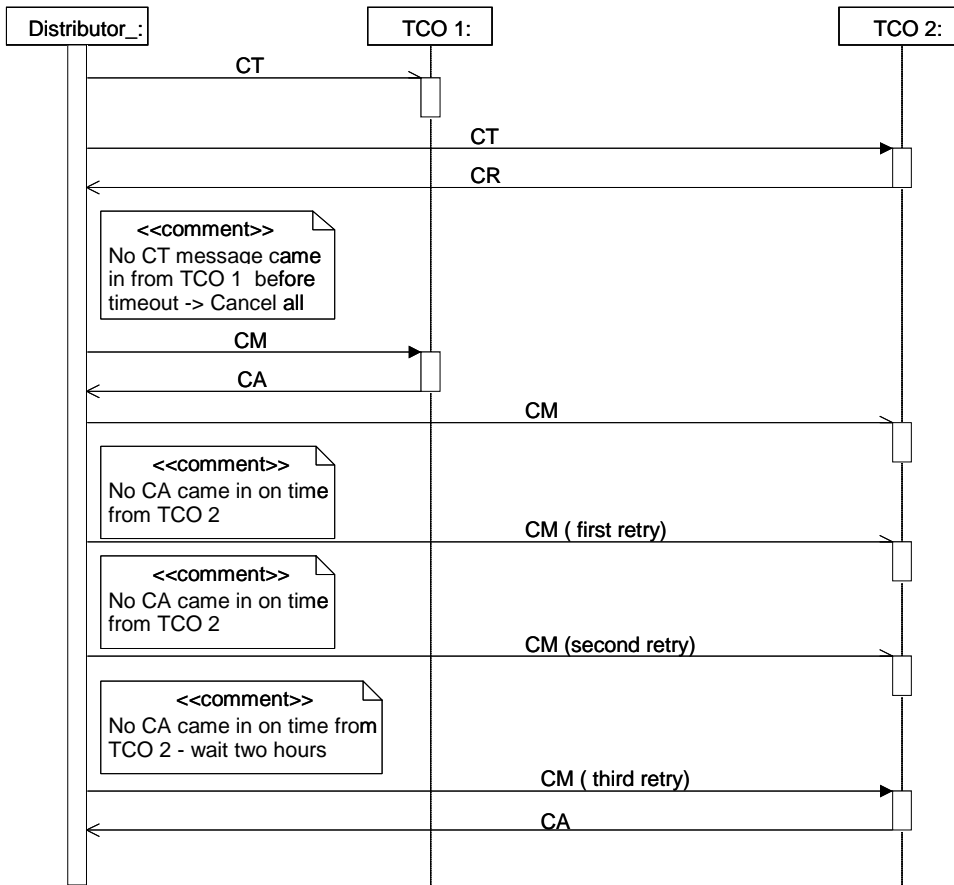

Fig. 33 - Special case 1 - no answer from TCO1

8 - Specification of Digitally Signed Ticket (DST)

8.1 - Mechanism

8.1.1 - Introduction

Instead of generating the certificates itself, the TCO can offer the distributor the possibility to do it locally by means of public key cryptography. This will result in a certificate that is larger than the certificate obtained by using symmetric key-pairs. An alphanumeric presentation will therefore not be useful and a common one-dimensional barcode can no longer be used. A possible solution to integrate these data in the paper ticket is a two-dimensional barcode.

The standard will describe the mechanism the different companies will have to follow if they choose this option. It speaks for itself that this choice will be the result of a bilateral agreement.

8.1.2 - Composition of the DST content

The content of the DST in international passenger traffic is composed as follows:

1. Message header with message ID and digital signature
2. Main record
3. Record with RCT2 ticket layout
4. Record(s) based on specific TCO standards (optional).

The definition of these record types is appointed in the following chapters of this document.

The sequence of the records is seized by means of a compressing technique and then displayed on the support medium (2D Barcode, Smartcard, etc.).

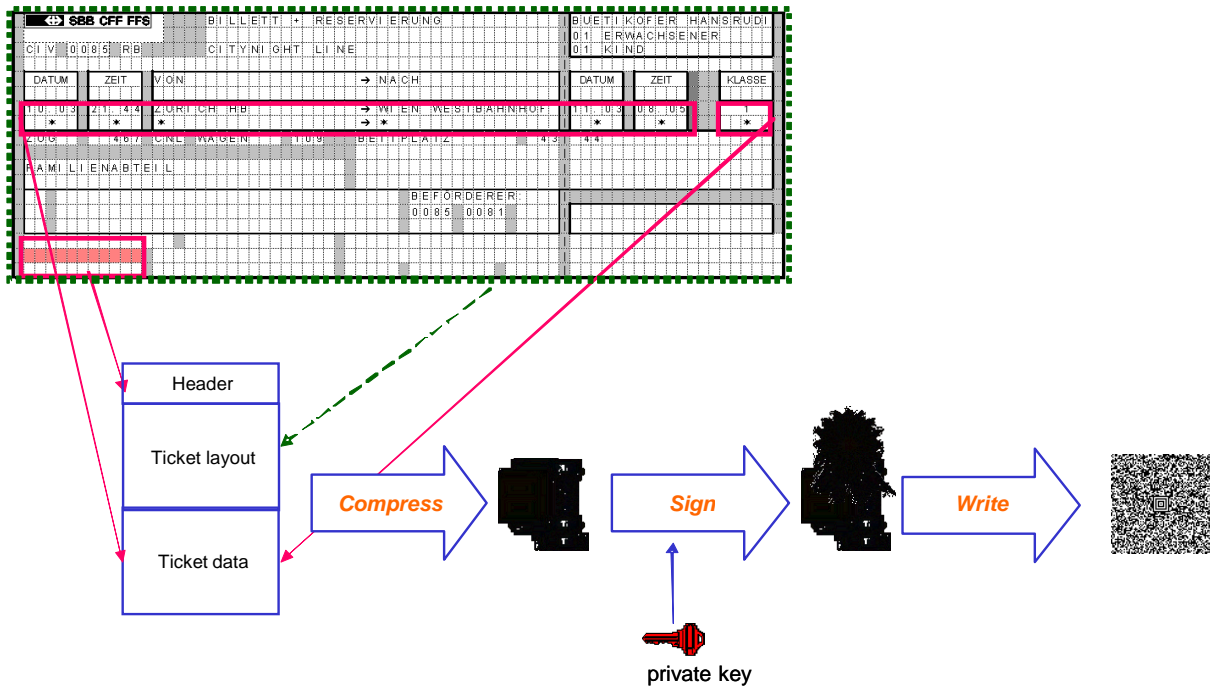

Fig. 34 - Survey on generating the DST

8.1.3 - Control of the DST

The control process by means of an apparatus contains the following steps:

1. Reading the content of the DST (2D Barcode, Smartcard, etc.)
2. Decompressing the content
3. Checking the signature by means of a public key. If the result is negative, the train staff member of the TCO receives a corresponding notice
4. Output of the content of the ticket on the display (in the layout of the ticket printout)
5. Automatic check of some essential ticket attributes (journey date etc.)
6. Receiving the outcome of the control of the train staff member of the TCO.

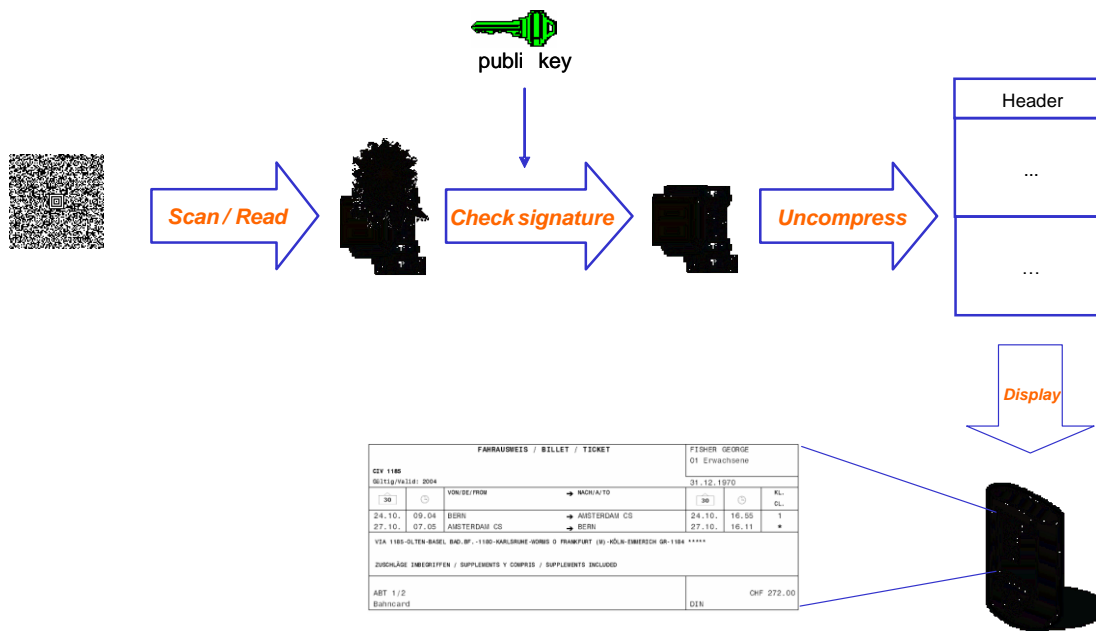

Fig. 35 - Overview of the online ticket control

NB : If the validation of the signature takes too long (conform calculating power of the apparatus), the steps "signature check" and "Output of the content of the ticket on the display" can be switched. The signature check can take place while the train staff member of the TCO is controlling the ticket visually. In that case, an invalid signature is notified by a certain temporary delay. Since this is rather an exception, it's not a constraint for the normal control process.

8.1.4 - Compressing procedure

For the compressing procedure an algorithm jointly agreed by distributor and TCOs will be applied.

8.1.5 - Character encoding

In Textfields with fixed length, special characters are not permitted. Only characters that are translated in one byte using the UTF-8 encoding, are allowed.

Textfields with a variable length may contain special characters. The strings must be encoded using UTF-8 transformation.

Special characters will increase the length of the encoded string, since they are encoded using several octets.

NB : the value of the according length field must be determined after encoding the text, in order to allow decoding the entire text again when parsing the content.

8.2 - Definition of the record structure

Each record type is composed according to the following pattern:

Number in sequence	Element	Number of characters	Mandatory	Code	Comments
1	Record ID	6A	X	X	Composition: - "Uxxxxx" for record types, standard in TAP TSI. "xxxxx" is variable and determines the type - "4 characters Company Code" + "xx" for record types defined by separate TCOs. "xx" is variable and can be filled in freely by the TCO for each type (2 characters)
2	Record version	2N	X		Allows different versions of one record type (having the same record ID)
3	Record length	4N	X		Number of characters starting from the record beginning (from the first character of the element "record ID")
...	...	A			The actual fields of the records

8.3 - Definitions of the general record types

Main record (U_HEAD)

This record is mandatory for DSTs in accordance with ERA TAP TSI Technical Document B.5.

The main record contains information in common with all the transport documents (regardless of the ticket layout standard, a domestic or international ticket).

Number in sequence	Element	Number of characters	Mandatory	Code	Comments
1	Record ID	6A	X	X	ID is "U_HEAD" ("header")
2	Record version	2N	X		"01"
3	Record length	4N	X		
4	Company code of the distributing RU	4N	X	X	Distributor, producing the tickets
5	Unambiguous key of the tickets	20A	X		The producer can complete this key freely; a specific key can only be used for one ticket. In combination with the Company code this key provides a global unique key for each ticket within the EU.
6	Edition time	12N	X		Format "DDMMYYYYHHMM" This can be used to prevent fraud by buying a ticket after journey departure (only shortly before the conductor shows up)
7	Flags	1N	X	X	- International ticket: 1 - Edited by agent: 2 - Specimen: 4 The field is the decimal representation of the sum according to the flags set. E.g.: "6" means national ticket, edited by agent, specimen
8	Edition language of the tickets	2A	X	X	ISO 639 - 1 (see Bibliography) country code definitions and abbreviations
9	Second language of the contract of carriage (See ERA TAP TSI TD B.6)	2A	X	X	ISO 639 - 1 country code. If no second language is used, this field is filled with blanks

8.4 - Definition of the record types for the ticket data according to the TAP TSI standard

In this chapter the record types containing the actual information of online tickets (print attributes) are defined. These contents allow the essential control of the ticket by means of a control apparatus.

Record of the ticket data "Ticket Layout" (U_TLAY)

This record is mandatory in DSTs in accordance with ERA TAP TSI T. D. B.5, and for international tickets it's mandatory that the layout standard used is "RCT2" (see element 4).

This record represents the entire information of the attribute fields on the printed ticket layout, so that a complete control of the ticket is possible without making an online connection to the vending system.

Note that only layout fields with variable content should be included in this record. Fields which have the same content for all tickets of a given layout standard (e.g. labels), will be completed by the control apparatus. In particular for "RCT 2" based layouts all labels on line 5 (E) may not be included.

To control offline, the entire content of the "ticket layout" field is extracted from the DST and shown on the display of the control apparatus. The layout must correspond exactly with the printed ticket.

This record only refers to the ticket content and not to a specific layout standard (for example "RCT 2"). In combination with the DST records specific for the TCO (see point 5.5), DSTs can therefore be created for any carrier specific ticket. Nevertheless international tickets always must follow the "RCT2" layout standard.

Number in sequence	Element	Number of characters	Mandatory	Code	Comments
1	Record ID	6A	X	X	ID is "U_TLAY"("Ticket layout")
2	Record version	2N	X		"01"
3	Record length	4N	X		
4	Layout standard	4A	X		For example "RCT2"
5	Number of fields	4N	X		Number of following fields
<i>The following elements define the individual text fields included on the ticket layout description formula. For each text field the elements are repeated (i= index of the text fields)</i>					
6 + 6 i	Field line	2N	X		Line index of the first letter. Range: 0 till 14
7 + 6 i	Field column	2N	X		Column index of the first letter. Range: 0 till 71
8 + 6 i	Field height	2N	X		Number of lines reserved from the field
9 + 6 i	Field width	2N	X		Number of columns reserved from the field

European Railway Agency

ERA/TD/2009-10/INT: ANNEX B.7 of TAP TSI

Number in sequence	Element	Number of characters	Mandatory	Code	Comments
10 + 6 i	Field formatting	1N	X	X	See code list B.7.6
11 + 6 i	Field text length	4N	X		Length of the following text. Caution: the length must be determined using the already encoded text
12 + 6 i	Field text	nA	X		<p>If "Field height" is bigger than 1, the text must be wrapped using the following rules:</p> <ul style="list-style-type: none"> - The first word that doesn't fit in the current field line, is printed at the beginning of the following line - If the field text contains the sign LF (ASCII "10"), the next word must be wrapped to the next line <p>The producer of the record must guarantee that the entire text, when applying these rules, fits within the indicated field sizes (height and width), can be entirely displayed</p>

NB : - When composing this record, one must pay attention to the fact that pictograms obviously can't be used in a field text. If the printed ticket contains pictograms, they must be replaced by a corresponding text. The language and content which are used to replace the pictograms must be set according to the standard that is used for the "Ticket layout" field (i.e. "RCT-2").

- Using "small font" formatting has no impact on the number of characters possible for a certain field. E.g. a field using "small font" formatting still has a maximum width of 71 characters, even if there is space left on the form. The "small font" format is therefore a pure formatting option which can't be used to increase the textual capacity of the ticket fields.

8.4.1 - Extraction of RCT 2 zones

If the element "Layout standard" in the "U_TLAY" record contains the value "RCT2", it means that the content of the "U_TLAY" record is composed according to the layout defined by this Technical Document. This allows extracting directly specific ticket attributes from the "U_TLAY" record.

The layout of the ticket according to RCT2 is subdivided in different zones containing distinct attributes (see ERA TAP TSI Technical Document B.6, *point 1.2.3*):

Zone	Content	Only 1 representation
1	Type of document, « CIV », responsible carrier in code, obliteration stamp, validity	
2	Family names / given names of the travellers and the number of adults and children	
3	Travel distance, departure date and time, arrival date and time	yes
4	Class	yes
5	Train, wagon, reserved seat (if not with compulsory reservation)	
6	Used rates, used commercial conditions (from 1 till n carriers)	
7	Currency and total amount for each ticket	yes

If the element "Layout standard" in the "U_TLAY" record contains the value "RCT2", separate zones (1 till 7) can be extracted on the basis of the subdivision of the ticket layout (from the record "U_TLAY"). This allows subdividing the information included in the "U_TLAY" record into coherent parts.

The subdivision in separate zones makes it possible to show the content of the "U_TLAY" record on the display of a control apparatus that is too small for the entire layout. In this case, the separate RCT 2 zones can be displayed consecutively and/or combined differently.

8.4.2 - Extraction of RCT2 ticket attributes

Beside the subdivision of the zones, the ERA TAP TSI Technical Document B.6 standard allows the extraction of separate ticket attributes (from the "U_TLAY" record). In the zones 3, 4 and 7 only one representation exists for all the different types of transport documents (see last column of the previous table). This means that the included ticket attributes are identical for all RCT 2 ticket types and these attributes can be extracted unambiguously.

The attributes that can be extracted are the following:

Zone 3: Travelling distance and time

Ticket attribute
Outward journey date of departure
Outward journey time of departure
Outward journey station of departure (Text form)
Outward journey station of arrival (Text form)
Outward journey date of arrival
Outward journey time of arrival
Return journey date of departure
Return journey time of departure
Return journey station of departure (Text form)
Return journey station of arrival (Text form)
Return journey date of arrival
Return journey time of arrival

Zone 4: class

Ticket attribute
Class

Zone 5: route

Ticket attribute
Route outward journey
Route return journey

Zone 7: monetary unit and amount

Ticket attribute
Monetary unit (abbreviation)
Amount
Mode of payment

8.5 - Record types for ticket data in accordance with the standards of a specific TCO

The distributing RU can include attributes in the DST that are not defined in the TAP TSI standard. The DST can also be used for national tickets that are not composed according to TAP TSI layout standards.

For these cases the RU can define its own record types. As long as the base structure of the record is respected (see point 8.2"Definition of the record structure"), no other directives for the internal composition of this record exist.

Number in sequence	Element	Number of characters	Mandatory	Code	Comments
1	Record ID	6A	X	X	Company code of 4 characters + ID (2 characters) The Company code is the code of the TCO defining the specific record type. The ID is composed by the TCO itself and contains 2 alphabetic signs that can be chosen freely
2	Record version	2N	X		
3	Record length	4N	X		
...	...	A	X		Next there are the actual elements of the record in accordance to the standard specific for the TCO

Example of an ID "1180XY" record:

Example of symbol	Meaning
"1180"	Company code of the DB
"XY"	ID of 2 characters to distinguish different record types of a TCO

8.6 - Definition of the entire DST message structure

The DST message structure is defined below. Similar to the record definitions it contains header elements containing type ID and version.

The entire content of the DST is protected by means of a digital signature, that guarantees:

- Integrity:
Even the smallest possible manipulation of the content (i.e. changing from 1st to 2nd class) leads to an invalid signature. Forged DSTs will be recognized immediately by verifying the signature.
- Authenticity:
Since only the possessor of the private key is able to create the signature, the authorship of the DST is proved.

Because the key necessary for the control of the signature can not be fully protected against theft (due to its presence on each control apparatus), an asymmetric algorithm is used (public/private key). The message header thus contains a signature generated from the algorithm DSA ("digital signature algorithm").

Definition of the entire DST message structure:

Number in sequence	Element	Number of characters	Mandatory	Code	Comments
1	Unique Message type ID	3A	X	X	"#UT" for TAP TSI Ticket
2	Message type version	2N	X		"01" (Version of this Technical Document)
3	Company Code of the RU that is signing	4N	X	X	Allows the identification of the public key necessary for the verification in combination with the following element
4	ID of the signature key	5A	X		The ID must be managed by the RU issuing the signature key
5	Signature	50A	X		DSA signature for the message after compression (next element) in ASN.1 representation (see list of abbreviations). If the actual ASN.1 representation is shorter than 50 bytes, it should be enlarged to the length of 50 by adding null bytes
6	Length of compressed message	4N	X		
7	Compressed message	A	X		The entire record sequence compressed with DEFLATE

8.7 - 2D Barcode symbol

When the DST is edited as a 2D barcode, the following specifications are mandatory:

Parameter	Value	Comments
Symbology used	Aztec	
Number of modules	87	This means 17 Aztec layers (see Aztec standard)
Capacity	max. 621 Bytes	Binary data (8 bit). This limit may not be exceeded; otherwise the fault correction is jeopardized. If necessary, optional DST records must be omitted
Physical size	50 x 50 mm	The size of the entire 2D barcode results from the recommended element size for the printout on the home printers (inkjet lowcost): Optimal recommendation: 25 mil/ elem. Minimal recommendation: 15 mil/ elem. (with 50 x 50 mm results in an element size of 23 mil) 1 mm = 40 mil
Share of fault correction data	23 %	This value results from the previous values when using the full capacity. For Aztec 23% is the standard value for fault correction

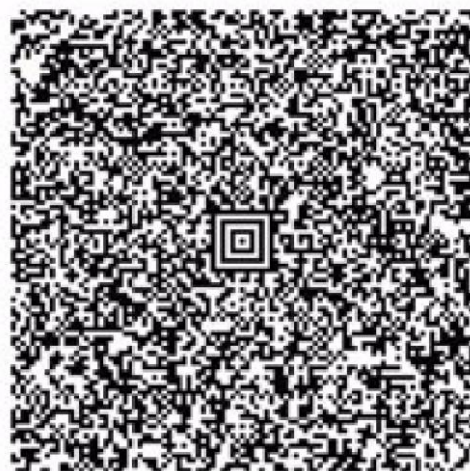

Fig. 36 - Example for 2D Barcode symbology in accordance with specification

8.8 - Key management

8.8.1 - Duration of validity of the signature key

Since the signature algorithm DSA is an asymmetric and robust cryptographic procedure, the key pairs must in general be rarely switched. A relative long duration of validity can be chosen.

The maximum duration (e.g. **12 months**) is defined in each bilateral agreement.

Tickets can be valid over longer periods (e.g. 2 months or more) and only one signature per ticket is possible, therefore the validity periods of subsequent keys must overlap. The overlap period must be at least as long as the maximum ticket validity time span (minus 1 day).

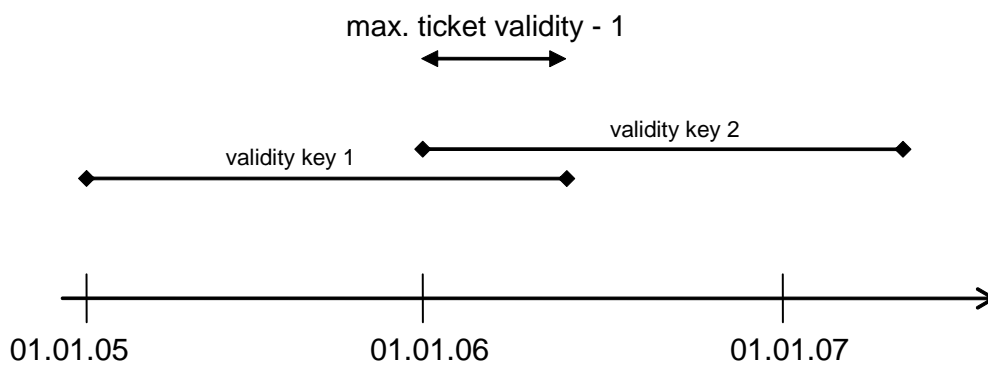

Fig. 37 - Example for key validity overlap

8.8.2 - Test key pairs

Some testing scenarios can require a special set of keys, which are used on pre productive system platforms. Since productive ("live") private keys usually can't be deployed to testing platforms for security reasons, special testing key pairs must be used in this context. Testing keys must have an ID beginning with "TT" (for details about the key ID see point 8.6, element 4 "ID of the signature key").

Sample for a test key ID: "TT001 ".

The test key pairs are deployed on test environments, which usually can't guarantee a defined security level. Due to this situation it is very important to be aware that tickets signed using a test key can never be considered as valid, even if the specimen flag of the DST message is not set. It is the responsibility of each TCO to ensure that their controlling devices follow this policy and always display these tickets with the indication "Test" or "Specimen".

On the other hand the ticket distributor is fully responsible to guarantee the secrecy of its productive private keys. Any ticket signed with a non-test private key will be considered as authentic by a TCO.

8.8.3 - Exchange of signature keys (public keys) with partner companies

The period of validity of a key pair is defined in each bilateral agreement. Since the public keys must be distributed on the control apparatus of the different RUs, the exchange of a key must take place in advance of its validity time span.

The public keys must be at the disposal of the different RUs at the dates defined in the bilateral agreements.

The message format and communication infrastructure used to transfer the public keys is defined in the bilateral agreements. The use of key certificates (signed by a certification authority) can be agreed bilaterally.

9 - Option: list with cancelled certificates (CMC, CKC)

Cancelling the tickets using the standard in a system with a (supplementary) check where ticket info is checked versus stored information).

Distributor:

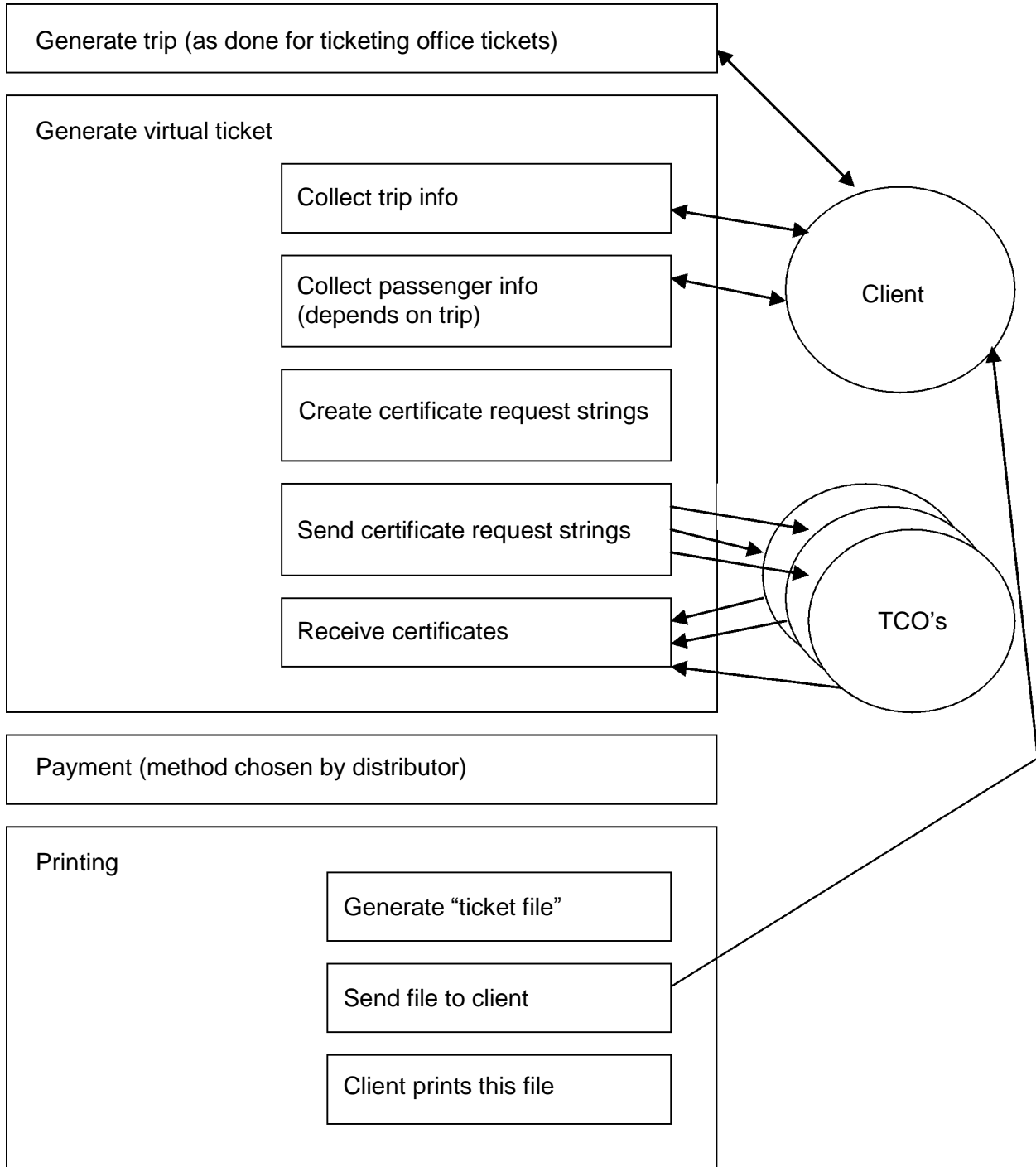

Fig. 38 - The home-printed ticketing scheme

European Railway Agency

ERA/TD/2009-10/INT: ANNEX B.7 of TAP TSI

If in the payment-phase or in the printing-phase something goes wrong, the ticket will be cancelled (everything created in the "generate ticket phase"). The certificates that were made by the TCOs (in case of CMC or CKC) or by the distributor (DST) will not be used on a ticket.

Since several RUs are using a closed system, it can be interesting to communicate which of their generated certificates can/cannot be used on the tickets. A system like this can prevent that cancelled or used tickets are being used or used again.

To do this, the distributor can send the TCO a list of all the reference numbers (numbers of the distributor when demanding the certificate) that cannot be used because the ticket has been cancelled or has not been paid (because there is a problem with the payment by credit card or a problem with the creation of other certificates of other TCOs causing a cancellation of the transaction).

The cancellation of the tickets in the reservation system has nothing to do with this cancellation and must be done separately (cancellation of the "generate trip" phase).

In case of a CKC-system, these cancellation messages are very likely to be used, but even in the CMC-system it can be applied.

Definition of the cancellation message:

Number in sequence	Element	Number of characters	Mandatory	Code	Numeric	Comments
1	Message type	2	X	X		ID is "CA" (cancellation)
2	Number of records	5	X		X	
<i>The following 3 elements describe the records, corresponding with certificate requests to be cancelled. For each certificate request the elements are repeated (i= index of text field).</i>						
3 + 3 i	Sequence number of record	5	X		X	
4 + 3 i	Certificate Request ID	20	X			
5 + 3 i	TCO transaction ID	20	X			In case the distributor received an answer from the TCO

10 -Procedure for making home-printed tickets

- Client logs in to www.mydistributor.com;
- Client chooses his/her journey (itinerary depends on timetable, date, number of persons travelling,...);
- Distributor proposes a price (possibly it has to consult several carriers when integrated reservation tickets depend on the availability);
- Client chooses;
- Distributor generates the ticket according to the ERA TAP TSI Technical Document B.6 layout;
- Distributor knows the TCOs and the elements they use to generate their certificates;
- Distributor makes a list of all the data it needs from the client in order to have the certificates generated for/by ¹ every TCO;
- Distributor collects these data;
- Distributor sends the TCOs in question all the elements they need to generate their certificates¹;
- Distributor generates the certificates using DST with the keys as defined in the bilateral agreements²;
- The TCOs return their certificates to the distributors¹;
- When there are error messages or time-outs: STOP¹;
- Generate the A4-ticket;
- Payment by the client;
- The A4-ticket is sent to the client by the distributor.

2. DST

1. CMC, CKC

List of abbreviations

ASCII	American Standard Code for Information Interchange: a character set and encoding
ASN.1	Abstract Syntax Notation one, see ISO/IEC 8824
CA	Cancellation Acknowledgement (Message)
CIV	Uniform rules concerning the contract of international carriage of passengers by rail
CKC	Carrier Keeps Contract
CM	Cancellation Message
CMC	Carrier Makes Certificate
CR	Certificate Request (Message)
CT	Certificate Transfer (Message)
DSA	Digital signature algorithm, see [FIPS186]
DST	Digitally Signed Ticket
EDIFACT	Electronic Data Interchange For Administration, Commerce and Transport, see ISO 9735
H2H	Host to host - coding using a bilateral agreed standard
IRTHP	International Rail Ticket for Home Printing
ISO	International Organisation for Standardisation
O/D	Origin / Destination
PKI	Public Key Infrastructure
RU	Railway Undertaking
TCO	Ticket Controlling Organisation
UTF-8	Unicode Transformation Format variable-length character encoding for Unicode data
XML	eXtended Markup Language W3C-recommended general-purpose markup language
1 D barcode	1 dimensional barcode (uses vertical bars for data encoding)
2D barcode	2 dimensional barcode (uses a 2 dimensional matrix for data encoding)

Bibliography

1. ERA TAP TSI Technical Documents

ERA TAP TSI Technical Document B.5: *Electronic reservation of seats/berths and electronic production of travel documents - Exchange of messages*, version 1.1, 05.05.2011

ERA TAP TSI Technical Document B.6: *Electronic seat/berth reservation and electronic production of transport documents - Transport documents (RCT2 Standard)*, version 1.1, 05.05.2011

ERA TAP TSI Technical Document B.8: *Standard Numerical Coding for Railway Undertakings, Infrastructure Managers and other companies involved in rail-transport chains*, version 1.1, 05.05.2011

ERA TAP TSI Technical Document B.9: *Standard numerical coding of locations*, version 1.1, 05.05.2011

2. International standards

International Organisation for Standardization

ISO 639-1: Codes for the representation of names of languages - Part 1: Alpha 2 code, 2002