

REFERENCE: A 11 T 6001 14.0.0	 INTERNATIONAL UNION OF RAILWAYS
Company / organisation	UIC ERTMS/GSM-R OFG EuroRadio Interface Group

Radio Transmission FFFIS for EuroRadio

ACCESS: Public

Restricted

Confidential

	NAME	DATE	VISA
Author	UIC ERTMS/GSM-R	December 2015	
Review	UIC ERTMS/GSM-R OFG EECT	September 2021 March 2022	Boris Gombač Begona Domingo
Approval	ERTMS/GSM-R UIC Chairman	March 2022	Robert Sarfati

EVOLUTION SHEET

Version	Date	Author	MODIFICATION
1	22 March 2002	EuroRadio Interface Group	First version based on MORANE FFFIS
2	6 May 2002	EuroRadio Interface Group	Second version
3	22 May 2002	EuroRadio Interface Group	Third version
4	04 June 2002	EuroRadio Interface Group & UNISIG	Fourth version based on comments received during 30/31 May Workshop
5	16 Sept 2002	EuroRadio Interface Group & UNISIG	Fifth version based on comments received by UNISIG
6	24 September 2002	EuroRadio Interface Group & UNISIG	Sixth version based on comments received during meeting #2
7	04 November 2002	EuroRadio Interface Group & UNISIG	Seventh version based on comments received by UNISIG
8	17 December 2002	EuroRadio Interface Group & UNISIG	Eighth version
9	13 January 2003	EuroRadio Interface Group & UNISIG	Ninth version
10	30 March 2003	EuroRadio Interface Group & UNISIG	Tenth version
11	02 April 2003	EuroRadio Interface Group & UNISIG	Eleventh version
12	12 09. 2003	EuroRadio Interface Group & UNISIG	Approved version for TSI
12.1	08.12.2011	UIC HQ	Proposal of change in 4.4 and insertion of Annex C
12.2	19.01.2012	ERA CG	Approval of change in 4.4 and insertion of Annex C
12.3	23.02.2012	ERA CG	Change in 4.4 and insertion of Annex C as (M) according to ERA CR 768
12.4	29.03.2012	ERA CG	Addition of AT+CRSM as (M) according to ERA CR 1018
12.5	08.07.2014	UIC	Insertion of PS-mode into the applicable chapters of the document

12.51	13.08.2014	UIC	UNISIG review comments incorporated
12.52	20.08.2014	UIC	UNISIG, Network Rail and Alstom review comments incorporated
12.53	22.08.2014	UIC	ProRail review comments incorporated
12.54	26.08.2014	UIC	Topics discussed during WG meeting are incorporated in the clauses: 2.1.3.1.4, 2.1.3.1.6, 2.1.4.2, 4.6.2.1, 4.6.2.3, 4.6.4.4, 4.6.4.6, 6.2.4, 6.2.5
12.55	17.09.2014	ERTMS WG	Changes adapted according to the review comments starting from chapter 1 up to chapter 2.1.3
12.56	20.10.2014	ERTMS WG	Changes incorporated
12.57	21.10.2014	Alstom, Nokia, KCC, UNISIG, UIC	Changes incorporated in chapter 2.2 up to 4
12.58	28.10.2014	UIC	Document format adapted Chapter 6 IPv4 structure added
12.59	31.10.2014	UIC	Incorporated review comments
12.60	05.11.2014	KCC, Nokia, UIC, UNISIG	Review comments incorporated in chapter 4, 6 and the Annex Format of the document adapted
12.61	12.11.2014	DB, UIC	DB comments incorporated in chapter 2.1.3, & 2.5
12.62	12.12.2014	ERTMS WG	ProRail comments incorporated in chapter 2.1.3, 3.3.5 and Annex
12.63	16.06.2015	UIC, ERTMS WG	Definitions aligned in chapter 1.3.2, 2.1.3; 2.1.4, 2.2.2, 2.2.3, 4.4.3, 4.4.6.1, 4.6.2, 4.6.3, 4.6.4
12.64	23.06.2015	UIC, UNISIG (Siemens)	Changes in chapter 4.4.3
12.64r1	13.07.2015	ERTMS WG	DNS configuration for CS/PS-mode incorporated
12.64r2	19.07.2015	ERTMS WG	Review comments incorporated
12.64.r3	11.08.2015	DB / UIC	Annex A -E-DNS description incorporated -Structure Access Network, CS- and PS-domain incorporated

12.64r4	25.08.2015	ERTMS WG	4.4.3.2 changes incorporated “default”
12.64r5	09.09.2015	ERA EECT	Changes incorporated in 1.1.3, 2.3.1.27, 2.3.1.20/21; 2.5.1, Figure 4-1, 4.4.4.1, 4.6.2.1, Figure 5-4, 6.2.4, ANNEX B
12.64r6	21.10.2015	UIC OG#58	Review comments incorporated CR 1262 incorporated
12.64r7	26.10.2015	ERTMS WG	Changes in clause 3.3.5.1.2 Clauses added: 3.3.5.1.3; 4.6.4.15 – 18 ANNEX A Figure A-1 revised
12.64r8	13.11.2015	UIC/UNISIG ER WG	Clauses 4.6.4.19 – 4.6.4.22 incorporated
12.64r9	27.11.2015	ERA, UIC, UNISIG ER	Clause 4.6.4.17 number of port for PS-mode changed
12.64r10	01.12.2015	ERA, UIC	Updated clause 6.1.3
12.64r11	03.12.2015	ERA, UIC	Updated clause 2.1.3.23
12.64r12	10.12.2015	EOG	Updated clauses 1.1.1, 2.1.3.2, 2.1.3.3
12.64r13	15.12.2015	ERA	Updated clause 1.1.1
13.0.0	18.12.2015	UIC	Updated according to 9239 (CS), 9240, and paragraph numbering.
13.1.0	14.07.2021	UIC	Updated according to the following CRs: O- 9253-2.4, O-9265-2.3, O-9270-2.0, O-9277- 2.1, Abbreviations and definitions list updated, Figure A-1 aligned according to O- 2475, editorial changes.
13.2.0	07.10.2021	UIC	Updated according to CR O-9281-1.0,
13.3.0	19.11.2021	UIC	Updated according UNISIG comments, update according CR O-9281-1.2
13.3.1	11.03.2022	UIC	Reference list updated according conclusions of EECT 09.03.2022 and O-9281-2.0 1.3 Note under reference list added.
14.0.0.0	11.03.2022	UIC	Final draft version
14.0.0	03.06.2022	UIC	Approved version

Table of Contents

1	INTRODUCTION.....	8
1.1	Scope.....	8
1.2	Reference documents.....	9
1.3	References.....	10
1.4	Abbreviations and Definitions.....	15
1.4.1	<i>Abbreviations.....</i>	<i>15</i>
1.4.2	<i>Definitions.....</i>	<i>17</i>
1.4.3	<i>Applicability.....</i>	<i>18</i>
2	EURORADIO REQUIREMENTS.....	19
2.1	Bearer services and tele services.....	19
2.1.1	<i>CS-mode - Service Requirements.....</i>	<i>19</i>
2.1.2	<i>CS-mode - Service Access.....</i>	<i>19</i>
2.1.3	<i>PS-mode – Service requirements.....</i>	<i>19</i>
2.1.4	<i>PS-mode – Service Access.....</i>	<i>23</i>
2.2	Signalling.....	23
2.2.1	<i>IGSM.....</i>	<i>23</i>
2.2.2	<i>IFIX_CS.....</i>	<i>23</i>
2.2.3	<i>IFIX_PS.....</i>	<i>24</i>
2.3	Supplementary Services and Railway specific services.....	24
2.4	Deleted.....	25
2.5	Deleted.....	25
3	IFIX SPECIFICATION.....	26
3.1	Empty.....	26
3.2	CS-mode - Data Transmission on the I _{FIX_CS} Interface.....	26
3.3	CS-mode - Signalling Transmission on the I _{FIX_CS} Interface.....	26
3.3.1	<i>Deleted.....</i>	<i>26</i>
3.3.2	<i>CS-mode - I_{FIX_CS} Terminating Call Establishment.....</i>	<i>26</i>
3.3.3	<i>CS-mode - I_{FIX_CS} Call Clearing.....</i>	<i>27</i>
3.3.4	<i>CS-mode - Message Functional Definition and Contents.....</i>	<i>28</i>
3.3.5	<i>PS-mode – Data Transmission on the I_{FIX_PS} Interface.....</i>	<i>34</i>
4	IGSM SPECIFICATION.....	36
4.1	Interface Architecture.....	36
4.2	Interface Definition.....	37
4.2.1	<i>Functional Properties.....</i>	<i>37</i>
4.2.2	<i>Electrical Properties.....</i>	<i>38</i>
4.2.3	<i>Mechanical Properties.....</i>	<i>38</i>
4.3	Data Transmission on the Interface.....	39
4.3.1	<i>Used Circuits.....</i>	<i>39</i>
4.3.2	<i>CS-mode - Data Format for Asynchronous Operation.....</i>	<i>39</i>
4.4	Signalling Transmission on the Interface.....	39
4.4.1	<i>Physical Layer.....</i>	<i>40</i>
4.4.2	<i>AT Command Syntax and Procedures.....</i>	<i>41</i>
4.4.3	<i>TE-TA interface commands.....</i>	<i>42</i>
4.4.4	<i>Result Codes.....</i>	<i>44</i>
4.4.5	<i>CS-Mode Originating Call Establishment.....</i>	<i>46</i>
4.4.6	<i>Deleted.....</i>	<i>48</i>
4.4.7	<i>Call Clearing.....</i>	<i>49</i>
4.4.8	<i>DTE-DCE interface commands.....</i>	<i>50</i>

4.4.9	Generic DCE control commands	50
4.4.10	Network service related commands	51
4.4.11	Mobile Equipment control and status commands.....	53
4.4.12	Mobile Equipment errors.....	54
4.4.13	Call control commands and DCE control commands	54
4.5	MT2 Start-up procedure.....	55
4.6	PS-Mode	55
4.6.1	Mobile Class selection +CGCLASS	55
4.6.2	ETCS – priority registration	55
4.6.3	PS-domain – Network Registration/Deregistration +CGREG, +CGATT, +CGDCONT, +CGACT.....	58
4.6.4	Underlying TE-MT - IP protocol establishment and control.....	61
5	Message Flows	65
5.1	Deleted	65
5.2	CS-Mode - Calls Originated from Trainside to Trackside.....	65
5.2.1	Example: signalling during a CS-mode MOC.....	66
5.3	PS-Mode - GPRS/EGPRS Service Setup (PDN session establishment)	67
6	Numbering and Addressing	68
6.1	CS-mode	68
6.2	PS-mode.....	68
ANNEX A: SYSTEM ARCHITECTURE.....		69
A.1.	Overall Architecture	69
A.2.	GSM-R Network	71
A.2.1.	GSM-R Architecture	72
A.2.2.	GSM-R Terminals.....	74
A.2.3	On board architecture.....	74
A.3.	GSM-R CS-mode Network Termination (NT1).....	75
A.3.1.	ISDN Interface (I _{FIX_CS})	75
ANNEX B: DELETED		76
ANNEX C: ADDITIONAL INFORMATION ON SIGNALLING TRANSMISSION ON I_{GSM} INTERFACE.....		77

List of Figures

Figure 1-1	Euro Radio Interfaces.....	8
Figure 4-1	Interface between Terminal Equipment and "ETCS" MT	37
Figure 4-2	PPP based IP communication.....	61
Figure 5-1	MOC message flow.....	65
Figure 5-2	V.110 Signalling flow during MOC.....	66
Figure 5-3	PS-mode Signalling Flow during PDP context activation.....	67

List of Tables

Table 1-1 Document Reference	14
Table 1-2 Deleted.....	14
Table 1-3 Deleted.....	14
Table 2-1 ETCS subscriber QoS Profile - lower system layer operation	20
Table 2-2 ETCS subscriber QoS Profile - BSS scheduling parameter	21
Table 2-3 Call specific Supplementary Services	24
Table 2-4 Location dependent routing service.....	25
Table 3-1 CS-mode - Call Control Messages	28
Table 3-2 CS-mode - Terminating Call establishment message sequence	29
Table 3-3 CS-mode – Calling user initiated call clearing.....	29
Table 3-4 CS-mode – Called user initiated call clearing	29
Table 3-5 BC Information Element (Figure 4.11 and Table 4.6 [9]).....	30
Table 3-6 LLC Information Element	30
Table 3-7 LLC Information Element (Figure 4.26 and Table 4.18 [9])	31
Table 4-1 Signals required at I _{GSM} interface	37
Table 4-2 Pin layout of 25 pin connector.....	38
Table 4-3 TE-TA interface commands	43
Table 4-4 Summary of result codes in the mobility management, call control and session management procedures and during the ME status change	46
Table 4-5 CS-mode Bearer Service selection command syntax.....	46
Table 4-6 CS-mode Dial up command syntax	47
Table 4-7 Deleted.....	48
Table 4-8 CS-mode Call Clearing command syntax	49
Table 4-9 CS-mode Command Echo syntax.....	50
Table 4-10 Reset to default configuration command syntax	50
Table 4-11 Set to factory configuration syntax.....	50
Table 4-12 CS-mode network service command syntax	51
Table 4-13 Mobile network operator selection command syntax.....	52
Table 4-14 Phone Activity status command syntax.....	53
Table 4-15 Call control commands and DCE control commands	55
Table 4-16 Mobile Class selection command syntax	55
Table 4-17 Bearer Service QoS parameter command syntax	57
Table 4-18 Bearer Service QoS verification command syntax.....	57
Table 4-19 PDP Context modification command syntax	57
Table 4-20 GPRS Network Registration status command syntax	58
Table 4-21 GPRS Attach command syntax	59
Table 4-22 PDP context configuration command syntax	59
Table 4-23 PDP context parameter settings.....	60
Table 4-24 PDP context status command syntax.....	60
Table 4-25 LCP configuration options	62
Table 4-26 NCP configuration options.....	62
Table 4-27 CGDATA command syntax	63
Table 4-28 CMUX command syntax.....	63
Table 4-29 Multiplexer mode – specific parameter values.....	64

1 INTRODUCTION

1.1 Scope

1.1.1 This Form Fit Functional Interface Specification (FFFIS) defines the interfaces of the EuroRadio module and GSM-R network terminations and includes, in chapter 2, the Radio Communication System requirements to the air gap interface details that are required for the ERTMS system definition.

1.1.2 This FFFIS covers the EuroRadio / transmission system interface functionality and covers:

- Interface requirements
- Physical, Mechanical and Electrical properties
- Protocols and procedures (e.g. CS-mode Call establishment/PS-mode Context establishment and termination)
- Services
- Numbering and addressing.

1.1.3 EuroRadio stack shall support circuit switched (CS-mode) transmission mode and shall support packet switched (PS-mode). The only EuroRadio interfaces relevant to this FFFIS are I_{FIX_CS} , I_{FIX_PS} and I_{GSM} , that are directly connected to the transmission system, as depicted in the following figure:

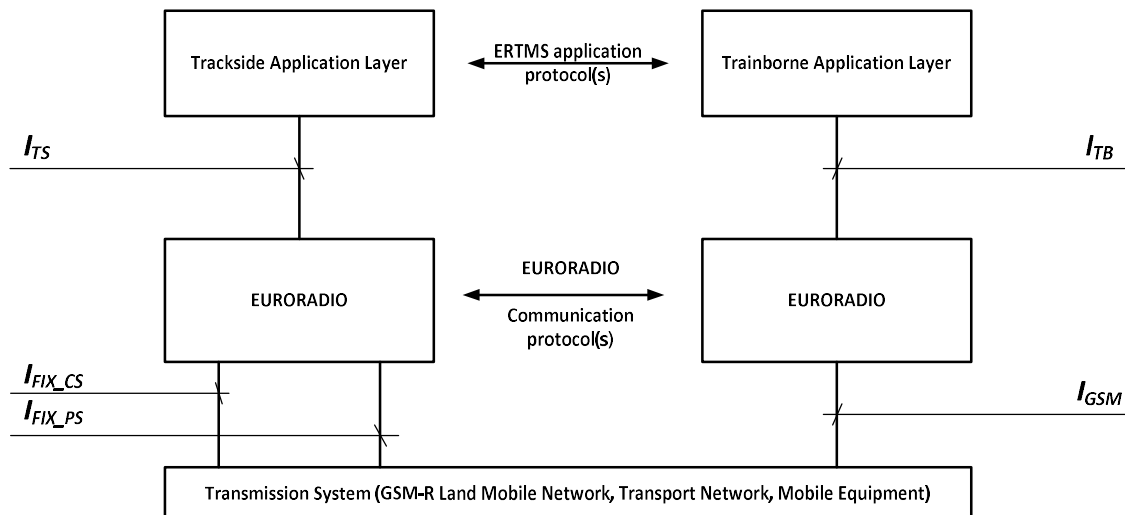

Figure 1-1 Euro Radio Interfaces

1.1.4 In considering all the messages which pass across the interfaces between the EuroRadio and the transmission system, only those which are utilised either to control the transmission system or are generated by the transmission system itself are relevant to this FFFIS.

1.1.5 Although messages sent between the EuroRadio (and higher layer) units pass across the I_{FIX_CS} , I_{FIX_PS} and I_{GSM} interfaces, their content is not relevant to the transmission system itself, since they are conveyed transparently. These messages are classified as EuroRadio specific and are outside the scope of this FFFIS.

1.2 Reference documents

- 1.2.1 This FFFIS incorporates dated or undated references. These normative references are cited at the appropriate place in the text and the publications are listed hereafter. For dated references, subsequent amendments to or revisions of any of these publications apply to this FFFIS only when incorporated in it by amendment or revision. For undated references, the latest edition of the publication referred applies.

1.3 References

1.3.1 The following is a list of normative reference specifications referred to within this FFFIS:

Reference	TITLE
[1]	Subset 026 ERTMS/ETCS System Requirement Specification
[2]	MORANE 1 FFFS for Location Dependent Addressing F 10 T 6001 2 FIS for Location Dependent Addressing F 12 T 6001
[3]	EIRENE System Requirement Specification
[4]	EIRENE Functional Requirement Specification
[5]	Subset 037-1 ERTMS/ETCS EuroRadio FIS
[5i]	Subset 054 Responsibilities and rules for the assignment of values to ETCS variables
[6]	ETSI ETS 300 011 - Integrated Services Digital Network (ISDN); Primary Rate User-Network Interface, Layer 1 Specification and Test Principles. Ed 1 and A2.
[7]	Deleted
[8]	ETSI ETS 300 097-1 - Integrated Services Digital Network (ISDN); Connected Line Identification Presentation (COLP) Supplementary Service; Digital Subscriber Signalling System No. One (DSS1) Protocol; Part 1: Protocol Specification
[9]	ETSI ETS 300 102-1 - Integrated Services Digital Network (ISDN); User-Network Interface Layer 3, Specification for Basic Call Control. It includes Ed.1 and A2.
[10]	ETSI ETS 300 125 - Integrated Services Digital Network (ISDN); User-Network Interface Data Link Layer Specification Application of CCITT Recommendations Q.920/I.440 and Q.921/I.441
[11]	ETSI EN 300 286 - 1 Integrated Services Digital Network (ISDN); User-to-User Signalling (UUS) Supplementary Service; Digital Subscriber Signalling System No. One (DSS1) Protocol; Part 1: Protocol Specification
[12]	ETSI EN 300 403 - 1 Integrated Services Digital Network (ISDN); Digital Subscriber Signalling System No. one (DSS1) protocol; Signalling network layer for circuit-mode basic call control; Part 1: Protocol specification
[13]	ETSI TS 122 002 - Digital cellular telecommunications system (Phase 2+) (GSM); Universal Mobile Telecommunications System (UMTS); Circuit Bearer Services (BS) supported by a Public Land Mobile Network (PLMN)

Reference	TITLE
[14]	Deleted
[15]	ETSI TS 100 907 - V7.1.1 Man-Machine interface (MMI) of the mobile Station (MS) (3GPP TS 02.30 version 7.1.1 Release 1998)
[16]	Deleted
[17]	Deleted
[18]	ETSI TS 100 551 V7.0.0 -GSM Public Land Mobile Network (PLMN) Access Reference Configurations (GSM 04.02 version 7.0.0 Release 1998)
[19]	ETSI TS 100 936 V8.1.2 Layer 1 - General Requirements (3GPP TS 04.04 version 8.1.2 Release 1999)
[20]	ETSI TS 100 937 V8.0.2 - Data Link (DL) Layer General Aspects (3GPP TS 04.05 version 8.0.2 Release 1999)
[21]	ETSI TS 100 938 V8.4.0 Mobile Station - Base Stations System (MS - BSS) Interface Data Link (DL) Layer Specification (3GPP TS 04.06 version 8.4.0 Release 1999)
[22]	ETSI TS 100 939 V7.3.0 - Mobile radio interface signalling layer 3; General aspects (GSM 04.07 version 7.3.0 Release 1998)
[23]	ETSI TS 100 940 V7.19.1 - Mobile radio interface layer 3 specification (3GPP TS 04.08 version 7.19.1 Release 1998)
[24]	ETSI TS 100 945 V8.1.0 - Rate adaption on the Mobile Station - Base Station System (MS - BSS) Interface (GSM 04.21 version 8.1.0 Release 1999)
[25]	ETSI TS 100 946 V7.1.0 - Radio Link Protocol (RLP) for data and telematic services on the Mobile Station - Base Station System (MS - BSS) interface and the Base Station System - Mobile-services Switching Centre (BSS - MSC) interface (GSM 04.22 version 7.1.0 Release 1998)
[26]	Deleted
[27]	Deleted
[28]	Deleted
[29]	Deleted
[30]	ETSI TS 123 003 : Digital cellular telecommunications system (Phase 2+); Universal Mobile Telecommunications System (UMTS); Numbering, addressing and identification
[31]	ETSI TS 123 060 : Digital cellular telecommunications system (Phase 2+) (GSM); Universal Mobile Telecommunications System (UMTS); General Packet Radio Service (GPRS) Service description; Stage 2
[32]	ETSI TS 123 107 V4.6.0: Universal Mobile Telecommunications System (UMTS); Quality of Service (QoS) concept and architecture

Reference	TITLE
[33]	ETSI TS 124 008 : Digital cellular telecommunications system (Phase 2+); Universal Mobile Telecommunications System (UMTS); Mobile radio interface Layer 3 specification; Core network protocols; Stage 3
[34]	ETSI TS 127 001 V4.14.0: Digital cellular telecommunications system (Phase 2+); Universal Mobile Telecommunications System (UMTS); General on Terminal Adaptation Functions (TAF) for Mobile Stations (MS)
[35]	ETSI TS 127 002 V4.0.0: Digital cellular telecommunications system (Phase 2+) (GSM); Universal Mobile Telecommunications System (UMTS); Terminal Adaptation Functions (TAF) for services using Asynchronous bearer capabilities
[36]	ETSI TS 127 003 V4.1.0: Digital cellular telecommunications system (Phase 2+) (GSM); Universal Mobile Telecommunications System (UMTS); Terminal Adaptation Functions (TAF) for services using synchronous bearer capabilities
[37]	Deleted Replaced by reference [47]
[38]	ETSI TS 127 010 V4.2.0: Digital cellular telecommunications system (Phase 2+) (GSM); Universal Mobile Telecommunications System (UMTS); Terminal Equipment to Mobile Station (TE-MS) multiplexer protocol.
[39]	ETSI TS 127 060 V4.3.1: Digital cellular telecommunications system (Phase 2+); Universal Mobile Telecommunications System (UMTS); Packet domain; Mobile Station (MS) supporting Packet Switched services.
[40]	Deleted
[41]	ETSI TS 143 064 V4.5.0: Digital cellular telecommunications system (Phase 2+); Overall description of the GPRS radio interface; Stage 2
[42]	ETSI TS 144 018 V4.23.0: Digital cellular telecommunications system (Phase 2+); Mobile radio interface layer 3 specification; Radio Resource Control (RRC) protocol
[43]	ETSI TS 144 060 V4.23.0: Digital cellular telecommunications system (Phase 2+); General Packet Radio Service (GPRS); Mobile Station (MS) - Base Station System (BSS) interface; Radio Link Control / Medium Access Control (RLC/MAC) protocol
[44]	ETSI TS 144 064 V4.4.0: Digital cellular telecommunications system (Phase 2+); Mobile Station - Serving GPRS Support Node (MS-SGSN); Logical Link Control (LLC) Layer Specification
[45]	Deleted

Reference	TITLE
[46]	Deleted
[47]	ETSI TS 103 368: Rail Telecommunications Commands necessary for mobile radio equipment operation on railways
[48]	IETF RFC 791 - (1981) Internet Protocol Version 4 (IPv4)
[49]	IETF RFC 768 - (1980): User Datagram Protocol (UDP)
[50]	IETF RFC 894 - (1984): "A Standard for the Transmission of IP Datagrams over Ethernet Networks"
[51]	IETF RFC 1332 - The PPP Internet Protocol Control Protocol (IPCP)
[52]	IETF RFC 1661 - The Point-to-Point Protocol (PPP)
[53]	Deleted
[54]	Deleted
[55]	Deleted
[56]	IETF RFC 1035 - Domain Names – Implementation and Specification
[57]	IETF RFC 1123 - Requirements for Internet Hosts -- Application and Support
[58]	IETF RFC 1877 - PPP Internet Protocol Control Protocol Extensions for Name Server Addresses
[59]	IETF RFC 1962 - The PPP Compression Control Protocol (CCP)
[60]	IETF RFC 1968 - The PPP Encryption Control Protocol (ECP)
[61]	IETF RFC 2181 - Clarifications to the DNS Specification
[62]	Deleted
[63]	IEEE 802.3 - IEEE Standard for Ethernet
[64]	ISO 1177 - Information processing: Character structure for start/stop synchronous character oriented transmission
[65]	ISO 2110 Amend.1 - Information technology: Data communications 25 pole DTE/DCE interface connector and contact number assignment
[66]	ITU-T I.255.3 - Integrated Services Digital Network (ISDN) general structure and service capabilities. Multi-Level Precedence and Pre-emption Service (MLPP)
[67]	Deleted
[68]	Deleted
[69]	ITU-T I.431 - Primary rate user-network interface – Layer 1 specification
[70]	Deleted
[71]	ITU-T Q.930 - ISDN user-network interface layer 3: General aspects

Reference	TITLE
[72]	ITU-T Q.931 (3/93) - Digital Subscriber Signalling System No.1 ISDN User-Network interface layer 3 specification for basic call control
[73]	Deleted
[74]	ITU-T Q.955.3 - Digital Subscriber Signalling System No.1 Stage 3 Description for Supplementary Services Using DSS1
[75]	ITU-T V.4 - General structure of signals of international alphabet No. 5 code for character oriented data transmission over public networks
[76]	ITU-T V.11 - Electrical characteristics for balanced double-current interchange circuits for general use with integrated circuit equipment in the field of data communications
[77]	ITU-T V.24 - List of definitions for interchange circuits between data terminal equipment (DTE) and data circuit-terminating equipment (DCE)
[78]	ITU-T V.250 - Serial asynchronous automatic dialling and control
[79]	ITU-T V.28 - Electrical characteristics for unbalanced double-current interchange circuits
[80]	ITU-T V.110 - Interworking with other networks Support by an ISDN of data terminal equipment's with V-Series type interfaces
[81]	ITU-T X.30 - Support of X.21, X.21bis and X.20bis based Data Terminal Equipment's (DTE) by an Integrated Services Digital Network (ISDN)
[82]	ITU-T Y.1541 - Network performance objectives for IP-based services
[83]	ITU-T E.164 - International operation – Numbering plan of the international telephone service: The international public telecommunication numbering plan
[84]	ETSI TS 100 921 v7.1.0 - Digital cellular telecommunications system (Phase 2+) (GSM); Service accessibility

Table 1-1 Document Reference

Note: For documents indexed in CCS TSI, the listed versions are applicable.

Table 1-2 Deleted

Table 1-3 Deleted

1.4 Abbreviations and Definitions

1.4.1 Abbreviations

APN	Access Point Name
ARP	Allocation Retention Priority
AT	ATtention command set
AuC	Authentification Centre (a GSM entity)
BS	Bearer Service
BSC	Base Station Controller (a GSM entity)
BSS	Base Station Sub-system (a GSM entity)
BTS	Base Transceiver Station (a GSM entity)
CHAP	Challenge Handshake Authentication Protocol
CCITT	International Telegraph and Telephone Consultative Committee
CS	Circuit Switched
DCE	Data Circuit Equipment
DL	Downlink
DLC	Data Link Connection
DNS	Domain Name Service
DTE	Data Terminal Equipment
EDOR	ETCS Data Only Radio
EF	SIM Card Elementary File
EGPRS	Enhanced GPRS
EIR	Equipment Identification Register (a GSM entity)
EIRENE	European Integrated Railway Enhanced Network
eMLPP	enhanced Multi-Level Precedence and Pre-emption (GSM service)
ERTMS	European Rail Traffic Management System
ETCS	European Train Control System
ETS	European Telecommunication Standard
ETSI	European Telecommunications Standards Institute
FFFIS	Form Fit Functional Interface Specification
FFS	For Further Study
FFFS	Form Fit Functional Specification
FIS	Functional Interface Specification
FQDN	Fully Qualified Domain Name
GBR	Guaranteed Bit Rate
GGSN	Gateway GPRS Support Node
GNS	GPRS Name Service
GPRS	General Packet Radio Service
GSM-R	Global System for Mobile communication - Railways
HDLC	High level Data Link Control
HLR	Home Location Register (a GSM entity)
IEEE	Institute of Electrical and Electronics Engineers
IETF	Internet Engineering Task Force
I _{FIX_CS}	(Trackside) EuroRadio Interface (ISDN/PSTN)
I _{FIX_PS}	(Trackside) EuroRadio Interface (IP Packet Data Network)
IP	Internet Protocol
I _{GSM}	(Train borne) EuroRadio Interface (GSM PLMN)

I _{TB}	Train borne Interface between EuroRadio and ERTMS Application
I _{TS}	Trackside Interface between EuroRadio and ERTMS Application
ISDN	Integrated Services Digital Network
ISO	International Standards Organisation
ITU-T	International Telecommunication Union - Telecommunication standardisation sector
LCP	Link Control Protocol
LFB	Look Forward Busy
LLC	Logical Link Control – PS-Mode
LLC	Lower Layer Compatibility – CS-Mode
MAC	Medium Access Control
MCC	Mobile Country Code
ME	Mobile Equipment
MLPP	Multi-Level Precedence and Pre-emption (ISDN service)
MNC	Mobile Network Code
MOC	Mobile Originated Call
MORANE	MOBILE radio for RAilway Networks in Europe
MRU	Maximum Receive Unit
MS	Mobile Station (a GSM entity)
MSC	Mobile Switching Centre (a GSM entity)
MSISDN	Mobile Station ISDN number
MT	Mobile Termination/Terminated
NCP	Network Control Protocol
NDC	National Destination Code
NI	Network Identifier
NMO	Network Mode of Operation
NSS	Network Sub-System (a GSM entity)
NT	Network Termination
OBU	On Board Unit
OI	Operator Identifier
OSI	Open System Interconnection
PAP	Password Authentication Protocol
PCU	Packet Control Unit
PDN	Packet Data Network
PDP	Packet Data Protocol
PFC	Packet Flow Context
PLMN	Public Land Mobile Network
POI	Point Of Interconnection
PPP	Point to Point Protocol
PRA	Primary Rate Access
PS	Packet Switched
PSTN	Public Switched Telephone Network
QoS / QOS	Quality of Services
RA / RA0	Rate Adaptation
RBC	Radio Block Centre
RLC	Radio Link Control
SDU	Service Data Unit
SGSN	Serving GPRS Support Node
SN	Subscriber Number

SRS	System Requirement Specification
SS	Supplementary Service(s)
TA	Terminal Adaptor/Adaptation
TCP	Transport Control Protocol
TE	Terminal Equipment
THP	Traffic Handling Priority
TTI	Transmission Time Interval
UDP	User Datagram Protocol
UI	Unnumbered Information
UIC	Union Internationale des Chemins de Fer
UL	Uplink
Um	GSM air interface
UUS	User-to-User Signalling (ISDN service)
VLR	Visitor Location Register (a GSM entity)
WG	Work Group

1.4.2 Definitions

AT COMMAND SET An internationally accepted command language, originally for use with intelligent modems. [78]

CELL CHANGE/RESELECTION is an autonomous mobile station controlled process to reselect between radio cells while the mobile station is involved in a PS-mode data transfer (GPRS/EGPRS).

CS-MODE: Circuit Switched mode requires a dedicated end-to –end transmission resource for each subscriber.

DATA: Information and control signals passed by electronic means. They can include short formatted data messages; data file transfer; interactive computer operation; text messaging; alarms; and remote-control applications.

MOBILE CLASS: GPRS/EGPRS mobile stations are classified into mode of operation A, B and C classes.

Class A mobile stations can simultaneously connect to the CS-mode core network (MSC or MSS/MGW) and to the packet switched core network (SGSN). The class A mobile user can make/receive CS-mode calls and is able to receive/transmit PS-mode data.

Class B mobile stations are attached simultaneous to packet and circuit switched mode service. It can only operate one set of services at a time, CS-mode can suspend PS-mode data transmission.

Class C mobile stations are restricted even more in their capabilities to operate simultaneous CS-mode and PS-mode services. It can be attached either to the CS-domain or to the PS-domain. The domain selection is done manually and does not allow simultaneous operation.

ERROR: An error is that part of the system state which is liable to lead to failure. A transmission error occurs if the received message is different from the transmitted message.

EUROPEAN RAIL TRAFFIC MANAGEMENT SYSTEM (ERTMS): A harmonised means of controlling and managing railway traffic in Europe.

HANDOVER: The process of automatically transferring (an) active, dedicated bearer service(s) of a mobile station (e.g. a CS-mode call) between cells. The process as such is commanded by the network.

IDENTIFICATION: The recognition of an entity (with a distinguishing identifier) by another entity.

INTERFACE: The point at which two or more systems or subsystems meet.

MESSAGE: A complete data packet passed from one entity to another.

MULTISLOT CONFIGURATION: A Multislot configuration consists of multiple circuit or packet switched TDM radio traffic channels together with the associated control channels, assigned to the same MS. A Multislot configuration can occupy up to 8 basic physical radio channels, with different timeslots numbers but with the same frequency parameters (e.g. ARFCN, Training Sequence Code). Multislot configuration can aggregate several timeslots according to the Multislot class capabilities.

OCTET consists of 8 data bits.

PDP context comprises the access to an external packet data network (PDN).

PS-MODE: Packet Switched transmission mode shares (the) radio transmission resource(s) between several subscribers. Depending on the subscriber classification guaranteed or non-guaranteed resources can be assigned for packet data transmission purposes.

POINT OF INTERCONNECTION: Is the point where the GSM-R network (or eventually the transport network) and the EURORADIO trackside network are physically linked.

TRANSMISSION SYSTEM: The communication system/network bounded by, but excluding the trackside and train borne EuroRadio layers.

USER: A user can be an entity, an application or a person.

1.4.3 Applicability

The statements made in the specification are assigned to one of three categories:

Mandatory (indicated by ‘(M)’ at the end of the clause). Mandatory means that these specifications have to be met where interoperability is required.

Optional (indicated by ‘(O)’ at the end of the clause). Whilst not being mandatory for interoperability, these specifications shall be met if implemented, both to provide a consistent service and to present a recognised and agreed standard to manufacturers in order to facilitate the integration between equipment constituting part of the system, obtain economies of scale in development and manufacture.

Information (indicated by ‘(I)’ at the end of the clause). These are statements intended to provide explanatory notes.

2 EURORADIO REQUIREMENTS

- 2.0.1 This specification addresses the Point to Point data services in CS- and PS-mode.
- 2.0.2 This chapter provides a concise overview of the requirements of the I_{GSM}, I_{FIX_CS} and I_{FIX_PS} interfaces, based mainly on the stipulations within [1].

2.1 Bearer services and tele services

2.1.1 CS-mode - Service Requirements

- 2.1.1.1 Of the GSM bearer services (BSs) as defined in [13], the following asynchronous data services are to be used:
- BS25: Asynchronous data 4.8 kbps (M)
- 2.1.1.2 The GSM bearer services shall be operated in transparent mode, as defined in [25]. (M)
- 2.1.1.3 The GSM radio channel shall be full rate. (M)

2.1.2 CS-mode - Service Access

- 2.1.2.1 Deleted
- 2.1.2.2 Deleted

2.1.3 PS-mode – Service requirements

- 2.1.3.1 The Mobile Termination indicates the support of GPRS and EGPRS to the network and the network commands the mobile to make use of GPRS or EGPRS channel coding (in accordance to [41]). This process is hidden to the OBU. (I)
- 2.1.3.2 GSM PS-mode distinguishes between specific mobiles classes, the specific mobility management, session management functions (in accordance to [31]) and the related interaction between CS- and PS-mode. (I)
- 2.1.3.3 The following GPRS mobile class shall be used for the operation of ETCS:
- For an MS/MT that is used to provide CS-mode and PS-mode packet data transport services, Mobile class B shall be used. (M)

Note: A class B MT operates PS and CS services but not simultaneously (in accordance to [31]).

2.1.3.4 To achieve the performance of ETCS operation in PS-mode, erroneous packets (radio blocks), that are detected during radio link operation, shall be corrected by the Radio Link Control (RLC) protocol (in accordance to [43]). For this reason, the RLC protocol layer shall be operated in acknowledged mode. (M)

2.1.3.5 The operation of RLC acknowledged mode (clause 2.1.3.4), the QoS profile of “ETCS” APN shall provide the following parameter settings:

GPRS/EGPRS Radio Access Bearer QoS transport parameter in accordance to [32]	Parameter setting	Requirement
SDU error ratio	10 ⁻⁴	(M)
Residual bit error ratio	10 ⁻⁵	(M)
Delivery of erroneous SDUs	No	(M)

Table 2-1 ETCS subscriber QoS Profile - lower system layer operation

2.1.3.5i 3GPP specifications include logical link control (LLC) protocol that support different data protection levels between the mobile station and the SGSN (in accordance to [31]). (I)

2.1.3.6 LLC protocol layer (in accordance to [44]) shall be operated in unacknowledged mode. (M)

Note: Table 2-1 settings are applicable as well for the appropriate LLC operation mode.

2.1.3.7 Quality of Service parameters are part of the subscriber subscription profile. 3GPP specification introduced QoS traffic classes and attributes, to a have better control about the resource provision in the radio domain. (I)

2.1.3.8 To get the appropriate QoS inside the radio domain (BSS), the ETCS subscriber profile shall include the QoS parameter settings that are listed in Table 2-1 and Table 2-2. (M)

2.1.3.8i The subscribed GBR QoS parameter as listed in Table 2-2 can be overwritten by the network. (I)

GPRS/EGPRS Radio Access Bearer QoS parameter in accordance to [32]	Parameter setting	Subscribed Requested	Requirement
Traffic Class	Streaming	Subscribed Requested	(M) (M)
Traffic Handling Priority (THP) ⁽¹⁾	1	Subscribed	(M)
Transfer delay [ms] ⁽⁴⁾	N/A		
Allocation/Retention priority (ARP) ⁽²⁾⁽³⁾	1	Subscribed	(M)
Delivery order	No	Subscribed	(M)
Maximum SDU size [octets]	1500	Subscribed	(M)
Maximum bitrate [kbps]	64	Subscribed	(M)
Guaranteed bit rate [kbps] (applicable to Uplink and Downlink)	4 ⁽⁵⁾	Subscribed	(M)

Table 2-2 ETCS subscriber QoS Profile - BSS scheduling parameter

Note 1: Traffic Handling Priority is only applicable in interactive traffic class (degraded conditions), in case streaming traffic class cannot be allocated. In this case, the ETCS application get the best bearer quality by using THP=1.

Note 2: The allocation/retention priority attribute is a subscription parameter which cannot be negotiated by the mobile termination.

Note 3: Radio access network processes ARP attribute for allocation and retention of the radio transmission resource(s).

Note 4: Currently not used in GPRS/EGPRS. It is for future 3GPP radio access technologies which provide a lower air interface Transmission Time Interval (TTI) than GPRS/EGPRS.

Note 5: Chosen GBR value is according to the common ETCS traffic model.

2.1.3.8ii The traffic class parameter (see Table 2-2) shall be provided by the Mobile Termination when activating the PS-mode session (PDP context activation) towards the RBC. (M)

2.1.3.9 In accordance to [31], clause 9.1.2, an APN consists of a network identifier (NI) and an operator identifier (OI). The network identifier (NI) points to the external packet data network at Gi reference point (in accordance to [31]) and the operator identifier (OI) specifies in which Land Mobile Network the Gi reference point is located. The APN structure to be used is specified in [30]. (I)

2.1.3.10 The APN to be used for the operation of ETCS in PS-mode shall be of the format (M) <network id>.<operator id> .gprs. (M)

- **network id = “etcs”**
- **Operator id = “mncXXX.mccYYY.gprs” whereas**
 - XXX = MNC - Mobile Network Code 3digits

- YYY = MCC - Mobile Country Code 3digits
- 2.1.3.11 The <GPRS> Top Level Domain (in accordance to [30]) is part of the “APN Operator ID” and has a closed group assignment without Internet accessibility. (I)
- 2.1.3.12 The applicable APN operator identifier (APN-OI) shall be derived from the ETCS application network ID (NID_MN). (M)
- 2.1.3.13 The subscription of the “ETCS”-APN shall allow the access to a GGSN located in a Visited-GSM-R network (VPLMN=Yes). (M)
- 2.1.3.14 The IP based packet data network (PDN) shall provide during PS session protocol establishment one Domain Name Server IP address that can be used to resolve a RBC-ID into the relevant RBC IP address. (M)
- 2.1.3.15 ETCS Domain Name Server IP address shall comply with IPv4 (in accordance to [48]). (M)
- 2.1.3.16 The encoding of any RBC identifiers used as part of a Fully Qualified Domain Name (FQDN) shall follow the name syntax defined in [61], [56] and [57]. An FQDN consists of one or more labels. Each label shall be coded as a one octet length field followed by that number of octets coded as 8 bit ASCII characters. (M)
- 2.1.3.17 The FQDN used to identify RBC (ETCS trackside) equipment, shall comply with the following format (M):
- “id<unique ETCS-ID>.ty<ETCS-ID Type>.etcs” Unique ETCS-ID origins from [1].
 - ETCS-ID Type origins from [5]
e.g. “id031123.ty01.etcs”
- 2.1.3.18 The ETCS-DNS zone which contains the RBC resource records shall comply to the following format: (M)
- ty01.etcs.
- tyETCS-ID type
 - “01” determines the RBC
- Note: All other possible ETCS-ID types according to [5] are not applicable!*
- 2.1.3.19 If the RBC supports PS-mode capabilities, the DNS resource record “Type = A” shall provide the link between the logical IPv4 address and the ETCS-ID of the RBC. (M)
- 2.1.3.19i DNS resource records applicable for ETCS purposes as well as ETCS DNS queries shall only make use of the CLASS value “IN” (1, the Internet). (M)
- 2.1.3.19ii In case the RBC supports PS mode, the response to the DNS query to resolve a RBC FQDN shall encompass the corresponding IP address of the RBC given by the ETCS DNS server. (M)
- Note: Any recursion is to be done by the ETCS DNS server only.*
- 2.1.3.19iii The ETCS DNS client shall limit DNS queries to request either an A or TXT record. (M)

- 2.1.3.20 The DNS “Type=TXT” resource record in accordance to [56] shall be used to inform the on-board unit about specific ETCS system settings e.g. RBC transmission mode. (M)
- Note: The number of characters inside the TXT resource record is restricted to 255.*
- 2.1.3.20i The syntax for the specific ETCS system settings shall be applied in accordance to [5] e.g. "txm=cs;tp=0,1,0,0,1;". (M)
- Note: The quotation marks are not part of the TXT resource record.*
- 2.1.3.21 As delimiter for the ETCS system parameter in the TXT resource record, the semicolon “;” shall be used. (M)
- 2.1.3.21i The delimiter shall be used as well to complete the instruction(s) given in the TXT resource record i.e. “txm=cs;tp=0,1,0,0,1;”. (M)
- 2.1.3.22 Domain Name resolution of the RBC-FQDN shall be based on UDP transport protocol (in accordance to [56]). (M)
- 2.1.3.22i The TXT resource record used to notify TCP parameters shall only consist of one contiguous <character string>. (M)
- 2.1.3.22ii The total quantity of characters applicable to a TXT resource record shall be limited to the maximum UDP (in accordance to [49]) packet size of 512 octets applicable for the use of DNS transactions (in accordance to [56]). (M)
- 2.1.3.23 For the concurrent operation of several ERTMS applications, the MT shall support at least two PDP context that are simultaneously active. (M)

2.1.4 PS-mode – Service Access

- 2.1.4.1 The access point name shall be provided for mobile originated packet data protocol (PDP) establishment. (M)

2.2 Signalling

2.2.1 IGSM

- 2.2.1.1 For the mobile termination type MT2 the signalling over the IGSM shall be in accordance to [47] Release 99 and beyond. (M)
- 2.2.1.2. The MT2 maps the user signalling information from and to the GSM signalling information over Um which is in accordance to: (M)
- [19]: for layer 1 (General requirements);
 - [20], [21] and [43]: for layer 2 messages;
 - [22], [23] and [42]: for layer 3 messages.

2.2.2 I_{FIX_CS}

- 2.2.2.1 Signalling at I_{FIX_CS} interface shall conform to: (M)
- [6]: for layer 1 messages;
 - [10]: for layer 2 messages;
 - [9]: for layer 3 messages.

2.2.3 I_{FIX_PS}

2.2.3.1 Signalling at I_{FIX_PS} interface shall comply with:

- For layer 3 (network layer) messages (in accordance to [48]) - IPv4 (M);

2.3 **Supplementary Services and Railway specific services**

2.3.1 The following GSM and ISDN supplementary services apply:

UUS1	User-to-user signalling: Transfers user information during connection set-up or release	Should be used in accordance to SRS clause 4.3.3
MLPP	Multilevel priority and pre-emption within ISDN: Used to set ERTMS connections to high priority	Shall be used in accordance to [66] (M)
eMLPP	Enhanced Multilevel Precedence and Pre-emption within GSM-R: used to set ERTMS connections to high priority	Shall be used in accordance to SRS clause 4.3.3

Table 2-3 Call specific Supplementary Services

2.3.2 The following railway specific service as specified in [2] shall be mandatory provided:

Location dependent addressing	Used to route the call to the most appropriate RBC	(M)
-------------------------------	--	-----

Table 2-4 Location dependent routing service

2.3.3 Deleted

2.3.4 Deleted

2.3.5 For the ISDN SS UUS1, the [11] is applicable. (O)

2.3.6 For the ISDN SS MLPP, the [74] is applicable. (M)

2.4 Deleted

2.5 Deleted

I_{FIX} SPECIFICATION

- 3.0.1 This part of the specification applies to fixed equipment interfacing at I_{FIX} in CS-mode I_{FIX_CS} and PS-mode I_{FIX_PS}. PS-mode comprises GSM based packet switched extension based on GPRS/EGPRS.
These interfaces are the standard and recommended interfaces. (I)

3.1 Empty

3.2 CS-mode - Data Transmission on the I_{FIX_CS} Interface

- 3.2.1 The [69] is applicable to layer 1. The user network interface at 2048 kbps shall be used. (M)
- 3.2.2 The [80] and [81] are applicable for data transfer. (M)

3.3 CS-mode - Signalling Transmission on the I_{FIX_CS} Interface

- 3.3.0 The specification is based on the following standards: (M)
- Layer 1: [6]
 - Layer 2: [10]
 - Layer 3: [9] and [12] (modified [72]). This part of the EuroRadio FFFIS specification is delta-specification to [9]. Corrections of this standard described in Annex ZA of [12] related to the described application ETCS will be taken into account. The conformance to the [9] with the related corrections is considered to be sufficient; Conformance to [12] will be accepted too.

3.3.1 Deleted

3.3.2 CS-mode - I_{FIX_CS} Terminating Call Establishment

References within ETS 300 102-1 [9] :

- Clause 5.2.1 Incoming call: (M)
- Clause 5.2.2 Compatibility checking: (M)
- Clause 5.2.3.1 SETUP message delivered by point-to-point data link: (M)
- Clause 5.2.3.2 SETUP message delivered by broadcast data link: **not applicable**
- Clause 5.2.4 Overlap receiving: (M)
- Clause 5.2.5 Call confirmation: (M)
- Clause 5.2.6 Notification of interworking at the terminating interface: (M)
- Clause 5.2.7 Call accepted: (M)
- Clause 5.2.8 Active indication: (M)
- Clause 5.2.9 Non-selected user clearing:(M)

3.3.3 CS-mode - I_{FIX_CS} Call Clearing

References within [9]:

Clause 5.3.1 Terminology: (M)

Clause 5.3.2 Exception conditions: (M)

3.3.3.1 Clearing Initiated by the User

Clause 5.3.3 of [9] (M)

3.3.3.2 Clearing Initiated by the Network

Clause 5.3.4 of [9] (M)

3.3.3.4 Clear Collision

Clause 5.3.5 of [9] (M)

3.3.4 CS-mode - Message Functional Definition and Contents

List of Used Messages

	REFERENCE Clause of [9]
Call establishment messages: ALERTING CALL PROCEEDING CONNECT CONNECT ACKNOWLEDGE SETUP	 3.1.1 3.1.2 3.1.4 3.1.5 3.1.16 (see clause 3.3.4.2 below)
Call clearing messages: DISCONNECT RELEASE RELEASE COMPLETE	 3.1.6 3.1.11 3.1.12

Table 3-1 CS-mode - Call Control Messages

3.3.4.1 Deleted

- **Terminating Call establishment**

The following is the sequence of messages:

Messages	Direction
Setup	←
Call Proceeding	→
Alerting	→
Connect	→
Connect Acknowledge	←

Table 3-2 CS-mode - Terminating Call establishment message sequence

- **Clearing initiated by the calling user (same sequence at either end)**

The following is the sequence of messages:

Messages	Direction
Disconnect	→
Release	←
Release Complete	→

Table 3-3 CS-mode – Calling user initiated call clearing

- **Clearing initiated by the called user (same sequence at either end)**

The following is the sequence of messages:

Messages	Direction
Disconnect	←
Release	→
Release Complete	←

Table 3-4 CS-mode – Called user initiated call clearing

3.3.4.2 Information Elements in the SETUP Message

Clause 3.16 and table 3-16 of [9] are mandatory. In addition, the Information Elements ‘Bearer capability’, and ‘Low layer capabilities’ are defined below.

3.3.4.2.1 Bearer and Low layer capability information element

Bearer Capability: Clause 4.5.5 and table 4.6 of [9] are applicable;
 Low Layer Capability: Clause 4.5.18 and table 4.18 of [9] are applicable.

The coding of the fields must be as follows:

BC attribute	Verbose value	Bit Value	
Information transfer capability	unrestricted digital information	<u>54321</u> 01000	(octet 3)
Coding standard	CCITT	<u>76</u> 00	(octet 3)
Extension Bit	No extension	<u>8</u> 1	(octet 3)
Information transfer rate	64 kbps	<u>54321</u> 10000	(octet 4)
transfer mode	Circuit mode	<u>76</u> 00	(octet 4)
Extension Bit	No extension	<u>8</u> 1	(octet 4)

Table 3-5 BC Information Element (Figure 4.11 and Table 4.6 [9])

LLC attribute	Verbose value	Numeric Value	
Information transfer capability	unrestricted digital information	<u>54321</u> 01000	(octet 3)
Coding standard	CCITT	<u>76</u> 00	(octet 3)
Extension Bit	No extension	<u>8</u> 1	(octet 3)
Information transfer rate	64 kbps	<u>54321</u> 10000	(octet 4)
Transfer mode	Circuit mode	<u>76</u> 00	(octet 4)
Extension Bit	No extension	<u>8</u> 1	(octet 4) (*)

Table 3-6 LLC Information Element

(*) The optional bytes 4a and 4b have been deleted in accordance to [12] Annex ZA.1.2, 26

LLC attribute	Verbose value	Numeric Value	
User information layer 1 protocol	[80] / [81]	<u>54321</u> 00001	(octet 5)
Layer identification	User info layer 1 protocol	<u>76</u> 01	(octet 5)
Extension bit	Octet is continued	<u>8</u> 0	(octet 5)
User rate	4.8 kbps	<u>54321</u> 00101	(octet 5a)
Negotiation	In-band negotiation not possible	<u>6</u> 0	(octet 5a)
Synchronous/asynchronous	Asynchronous	<u>7</u> 1	(octet 5a)
Extension Bit	Octet is continued	<u>8</u> 0	(octet 5a)
Spare		<u>1</u> 0	(octet 5b)
Flow control on Rx	Cannot accept data with flow control	<u>2</u> 0	(octet 5b)
Flow control on Tx	Not required to send data with flow control	<u>3</u> 0	(octet 5b)
Network independent clock (NIC) on Rx	Cannot accept data with NIC	<u>4</u> 0	(octet 5b)
Network independent clock (NIC) on Tx	Not required to send data with NIC	<u>5</u> 0	(octet 5b)
Intermediate rate	8 kbps 16 kbps	<u>76</u> 01 10	(octet 5b)
Extension Bit	Octet is continued	<u>8</u> 0	(octet 5b)
Parity information	none	<u>321</u> 011	(octet 5c)
Number of data bits	8 bits	<u>54</u> 11	(octet 5c)
Number of stop bits	1 bit	<u>76</u> 01	(octet 5c)
Extension Bit	Octet is (not) continued	<u>8</u> 0/1	(octet 5c)
duplex mode	Full	<u>7</u> 1	(opt element: octet 5d)

Table 3-7 LLC Information Element (Figure 4.26 and Table 4.18 [9])

3.3.4.2.2 Called party number

Clause 4.5.8 of [9] is applicable.

The purpose of the Called party number information element is to identify the called party of a call.

Type of number (octet 3)

7 6 5

0 0 0	unknown (Note 1)
0 0 1	international number (Note 2)
0 1 0	national number (Note 2)
0 1 1	network specific number (Note 3)
1 0 0	subscriber number (Note 2)
1 1 0	abbreviated number (Note 4)
1 1 1	reserved for extension

Note 1: The type of number "unknown" is used when the user or the network has no knowledge of the type of number, e.g. international number, national number, etc. In this case the number digits field is organized according to the network dialling plan; e.g. prefix or escape digits might be present.

Note 2: Prefix or escape digits shall not be included.

Note 3: The type of number "network specific number" is used to indicate Administration/service number specific to the serving network, e.g. used to access an operator.

Note 4: The support of this code is network dependent. The number provided in this information element presents a shorthand representation of the complete number in the specified numbering plan as supported by the network.

Numbering plan identification (octet 3)

4 3 2 1

0 0 0 0	Unknown (Note)
0 0 0 1	ISDN/Telephony numbering plan (in accordance to [83])

Note: The type of number "unknown" is used when the user or the network has no knowledge of the numbering plan. In this case the number digits field is organized according to the network dialling plan; e.g. prefix or escape digits might be present.

3.3.4.2.3 Calling Party Number

Clause 4.5.10 of [9] is applicable.

The purpose of the Calling number information element is to identify the origin of a call.

Type of number (octet 3)

7 6 5

0 0 1 international number

0 1 0 national number

Prefix or escape digits shall not be included.

Numbering plan identification (octet 3)

4 3 2 1

0 0 0 0 Unknown (Note)

0 0 0 1 ISDN/Telephony numbering plan (in accordance to [83])

Note: The type of number “unknown” is used when the user or the network has no knowledge of the numbering plan. In this case the number digits field is organized according to the network dialling plan; e.g. prefix or escape digits might be present.

Presentation indicator (octet 3a)

7 6

0 0 presentation allowed

Screening indicator (octet 3a)

2 1

1 1 network provided

3.3.4.2.4 Priority

In accordance to [74] Clause 3, sub clause 3.3.1.1 terminal equipment invoking MLPP supplementary service should be able to indicate the precedence level of the call in the SETUP message and should support Cause values: #8, “pre-emption” and #46, “precedence call blocked”.

Existing precedence levels are:

0 (FLASH OVERRIDE - highest)

1 (FLASH)

2 (IMMEDIATE)

3 (PRIORITY)

4 (ROUTINE - lowest)

Precedence level FLASH has to be selected for ETCS calls.

LFB Indication

The parameter has to be set to:

1 Look Forward Busy not allowed

3.3.4.2.5 User-User Information Element

Clause 4.5.29 of [9] is applicable.

This information is not interpreted by the network, but rather is carried transparently and delivered to the remote user(s).

Protocol discriminator (octet 3)

8 7 6 5 4 3 2 1

0 0 0 0 0 0 0 0 User-specific protocol

The use of this information element is optional for the EURORADIO application.

3.3.5 PS-mode – Data Transmission on the I_{FIX_PS} Interface

3.3.5.1 Physical and MAC Layer

- 3.3.5.1.1 The interface shall support Ethernet as specified in the [63]. (M)
- 3.3.5.1.2 Improper duplex mode configuration of the I_{FIX_PS} interface can lead to performance degradations e.g. increased number of collisions. (I)
- 3.3.5.1.3 To determine the duplex mode of the I_{FIX_PS} interface, auto-negotiation function in accordance to the [63] shall be used. (M)

3.3.5.2 Layer 3 Network (IP) Layer

- 3.3.5.2.1 Internet Protocol version 4 (IPv4) (in accordance to [48]) for the communication between the On-board Unit (OBU) and the concerned trackside system(s) shall be used. (M)
- 3.3.5.2.2 The maximum transmission unit (MTU) (in accordance to [50]) of a packet using Ethernet shall not exceed 1500 octets. (M)
- 3.3.5.2.3 IPv4 header includes Type of Service (ToS) to prioritise IP traffic. Diff Service is another method that makes use of the ToS bits.
- 3.3.5.2.4 [82] specifies network QoS classes for IP based packet data networks wherefore Diff Service (Code Points) are used. (I)
- 3.3.5.2.5 In order to achieve End-to-End QoS (Mobile and Fixed IP network) the peripheral RBC communication port(s) shall be assigned to QoS class in accordance to [82] that provide high priority treatment of the ETCS application data packets. (M)

Note: An alignment between applicable mobile and fixed packet data network QoS parameter are necessary.

4 IGSM SPECIFICATION

- 4.0.1 This interface is the standard and recommended interface for CS- and PS-mode. (I)

4.1 **Interface Architecture**

- 4.1.1 [47] specifies a profile of AT commands that shall be used for controlling Mobile Equipment (ME) functions and GSM network services through a Terminal Adapter (TA). (M)
- 4.1.2 The IGSM interface corresponds to the interface between the Terminal Equipment (TE) and the “ETCS” MT. (I)
- 4.1.3 The interface offers different operational modes for the transmission of signalling information or user data, dependent upon the interface’s state: (I)

Command State: In the command state, the MT2 is not communicating with a remote station, and the MT2 is ready to accept commands.

Online Command State: In the online command state, the MT2 is communicating with a remote station, but treats signals from the TE as command lines and sends responses back to the TE. For EuroRadio application it is not desired to enter in the online command state, so the mechanism to switch from online data state to online command state defined in accordance to [78] clause 6.2.9 or by some other, manufacturer-defined, means (e.g. escape sequence “+++”) will be inhibited using AT\$2=128 and AT&D2 settings defined in the following clause 4.4.3.

Online Data State: In the online data state, the MT2 is communicating with a remote station. Signals from the TE are treated as data, which is transmitted to the remote station; conversely, data received from the remote station is sent to the TE. The online data state is entered from the command state after the reception of “Connect” message. Manufacturer-specific mechanism to enter the online command state shall not be used to guarantee interoperability. To avoid different behaviour, it is recommended to disable this escape sequence using the appropriate AT command usually referred as AT\$2=128. This particular command shall be sent to the Mobile termination as part of its initialisation string. State control using physical circuits is mandatory.

“ETCS” MT is the name used to indicate a MT2 housed in the Cab Radio, connected to the TE via IGSM interface.

In the following figure “ETCS” MT main constituent parties are shown: the Electrical Adapter, if present, is in charge to adapt the mechanical and electrical MT2 interface in accordance to sub clause 4.2.2 and 4.2.3 of this specification.

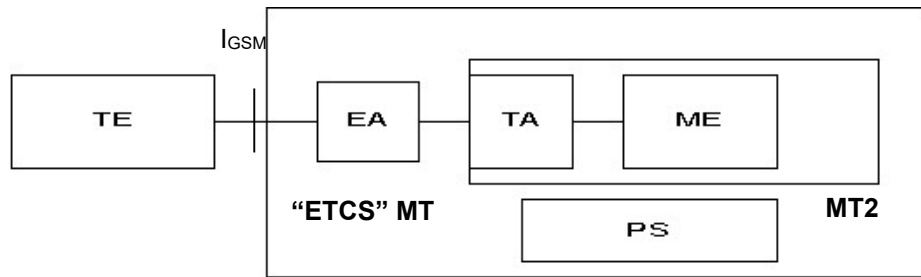

TE: Terminal Equipment
 EA: Electrical Adapter:
 TA: Terminal Adapter
 ME: Mobile Equipment
 PS: Power Supply

Figure 4-1 Interface between Terminal Equipment and "ETCS" MT

4.2 Interface Definition

4.2.1 Functional Properties

4.2.1.1 I_{GSM} shall conform to [77]. The signals required, (in accordance to [34], [35] / [36]) are shown in the following table: (M)

Circuit Number	Circuit Name	Asynchronous Services	Direction
CT102	Common Return	Mandatory	
CT103	Transmitted Data	Mandatory	
CT104	Received Data	Mandatory	
CT105	Request to Send	Mandatory	TE --> MT2
CT106	Ready for Sending	Mandatory	MT2 --> TE
CT107	Data Set Ready	Optional (*)	MT2 --> TE
CT108/2	Data Terminal Ready	Mandatory	TE --> MT2
CT109	Data Channel Received Line Signal Detector	Mandatory	MT2 --> TE
CT125	Calling Indicator	Optional (*)	MT2 --> TE

Table 4-1 Signals required at I_{GSM} interface

(*) ETCS application shall be able to work without the options

4.2.2 Electrical Properties

4.2.2.1 The interface signal's electrical characteristics shall conform to [79] or [76]. (M)

4.2.2.2 In order to resist electromagnetic disturbances within the railway environment, conformance of the interface signal's electrical characteristics to [76] is recommended: in accordance to [76], every signal at the I_{GSM} interface will have to be balanced. (O)

4.2.3 Mechanical Properties

4.2.3.1 The I_{GSM} interface shall conform to [65], if the related signal is defined as balanced in this recommendation. This international standard specifies a female 25-pole D-type connector on the mobile ("ETCS" MT) side. (O)

4.2.3.2 It is recommended that the pin lay-out will be compliant to Tab 4.2. (O)

Pin	V.11 [76]	V.28 [79]	Circuit Number	Circuit (V.24) [77]	
1	P-GND	P-GND		Protective Ground	M
2	Tx	Tx	103-A	Transmitted Data	M
3	Rx	Rx	104-A	Received Data	M
4	RTS	RTS	105-A	Request to Send	M
5	CTS	CTS	106-A	Ready for sending	M
6	DSR	DSR	107-A	Data Set Ready	O
7	GND (O)	GND	102-A	Signal Ground	M
8	DCD	DCD	109-A	Data Carrier Detect	M
9					
10	DCD	n.c.	109-B	Data Carrier Detect	M
11	DSR	n.c.	107-B	Data Set Ready	O
12					
13	CTS	n.c.	106-B	Ready for sending	M
14	Tx	n.c.	103-B	Transmitted Data	M
15					
16	Rx	n.c.	104-B	Received Data	M
17					
18	DTR	n.c.	108/2-B	Data Terminal Ready	M
19	RTS	n.c.	105-B	Request to Send	M
20	DTR	DTR	108/2-A	Data Terminal Ready	M
21					
22	RI	RI	125-A	Ring Indicator	O
23				Protocol Switch [79] / [76]: pin 23 not connected: [79] pin 23 connected to GND: [76]	O
24					
25	RI	n.c.	125-B	Ring Indicator	O

Table 4-2 Pin layout of 25 pin connector

4.3 Data Transmission on the Interface

4.3.0.1 This interface provides the transmission of transparent, full duplex, user data. (I)

4.3.1 Used Circuits

4.3.1.1 **Protective Ground** – As specified in [77] clause 3.1, within the DTE, this circuit should be brought to one point, and it should be possible to connect this point to protective ground or earth by means of a metallic strap within the equipment. This metallic strap can be connected or removed at installation, as may be required to meet applicable safety regulations or to minimize the introduction of noise into electronic circuitry. Caution should be exercised to prevent the establishment of ground loops carrying high currents. (I)

4.3.1.2 **Common Return (CT 102)** - This circuit is used in accordance to [79][79] for the proper recognition of signals on other circuits. (I)

4.3.1.3 **Transmitted Data (CT 103)** - Whilst in the online data state, data signals are processed by the MT2 and transmitted to the distant end. (I)

4.3.1.4 **Received Data (CT 104)** - Whilst in the online data state, the data received from the distant end is sent to TE on this circuit. (I)

4.3.2 CS-mode - Data Format for Asynchronous Operation

4.3.2.1 During the online data state, data transmitted between the TE and MT2 shall conform to the requirements for start-stop data transmission. The format of the used characters is defined by a data-parity-stop parameter set. This defines the number of data bits, the parity element and the minimum number of stop bits used between successive characters. The data-parity-stop configuration and data rate correspond to the bearer capability information element used in call set-up procedure. The 8N1 combination (8 data bits, no parity, and 1 stop bit) is required by EuroRadio. These values have to be the default settings by configuration. (M)

4.4 Signalling Transmission on the Interface

4.4.1 In accordance to [47]. Mapping of the [47] procedures to PLMN Dm-channel signalling is done by exchange of signalling information over the I_{GSM} interface. Annex C refers to additional information on signalling transmission on the interface related to network registration (M).

4.4.1 Physical Layer

4.4.1.1 Used Circuits

- 4.4.1.1.1 **Protective Ground** – As specified in [77] clause 3.1, within the DTE, this circuit should be brought to one point, and it should be possible to connect this point to protective ground or earth by means of a metallic strap within the equipment. This metallic strap can be connected or removed at installation, as may be required to meet applicable safety regulations or to minimize the introduction of noise into electronic circuitry. Caution should be exercised to prevent the establishment of ground loops carrying high currents. (I)
- 4.4.1.1.2 **Common Return (CT 102)** - This circuit is used in accordance to [79] for the proper recognition of signals on other circuits. (I)
- 4.4.1.1.3 **Transmitted Data (CT 103)** - Direction: to DCE - Whilst in the command state or online command state, data signals are processed by the MT2 and are not transmitted to the remote station. (I)
- 4.4.1.1.4 **Received Data (CT 104)** - Direction: from DCE - Whilst in the command state or on-line command state, the MT2 generates the responses on this circuit. (I)
- 4.4.1.1.5 **Request to Send (CT 105)** - Direction: to DCE - Signals on this circuit control the data channel transmit function of the DCE. The ON condition causes the DCE to assume the data channel transmit mode. The OFF condition causes the DCE to assume the data channel non-transmit mode, when all data transferred on circuit 103 have been transmitted. (I)
- 4.4.1.1.6 **Ready for sending (CT 106)** - Direction: from DCE - Signals on this circuit indicate whether the DCE is prepared to accept data signals (data transfer and commands) for transmission on the data channel or for maintenance test purposes under control of the DTE. The ON condition indicates that the DCE is prepared to accept data signals from the DTE. The OFF condition indicates that the DCE is not prepared to accept data signals from the DTE. (I)
- 4.4.1.1.7 **Data set ready (CT 107)** - Direction: from DCE - Signals on this circuit indicate whether the DCE is ready to operate. The ON condition indicates that the DCE is ready to exchange control signals with the DTE to initiate transfer of data. The OFF condition, in conjunction with the OFF condition on circuit 106, indicates that the DCE is not ready to operate in the data transfer phase. (I)
- 4.4.1.1.8 **Data Terminal Ready (CT 108/2)** - Direction: to DCE - Signals on this circuit indicate the status of the DTE. The MT2 may monitor changes in the state of this circuit and operate according the currently valid configuration (e.g. upon detecting an on-to-off transition, the MT2 enters the online command state or, the MT2 performs an orderly clear down of the call). (I)

- 4.4.1.1.9 **Received Line Signal Detector (CT 109)** - Direction: from DCE - Signals on this circuit indicate the detection of received line signal from the distant end. The TE may intercept this signal, so that the issue of result codes can be properly co-ordinated with the transitions in this signal. (I) (only valid for data calls)
- 4.4.1.1.10 **Calling Indicator (CT 125)** - Direction: from DCE - If provided by the MT2, the TE may intercept this signal, so that it can detect network alerting. (I)
- 4.4.1.1.11 The [24] refers to the frame structure and it identifies the use of status bits for the conveyance of signalling information. These status bits are used to convey the channel control information associated with the data bits which pass (in either direction) across the terminal adaptation interface during the online data or online command states. The status bit information is filtered and mapped onto the control circuit lines. (I)

4.4.1.2 Character Framing: formats for Asynchronous Operation

During the command state and online command state, data transmitted between the TE and MT2 shall conform to the requirements for start-stop data transmission as specified in [75] and [64]. The format of the characters used is defined by a data-parity-stop parameter set. This defines the number of data bits, the parity element and the minimum number of stop bits used between successive characters. The 8N1 combination (8 data bits, no parity, and 1 stop bit) is required by EuroRadio. These values have to be the default settings at power on or by auto-detection. (M)

4.4.2 AT Command Syntax and Procedures

4.4.2.1 Alphabet

Refer to [78] clause 5.1 (M)

4.4.2.2 Command Lines

Refer to [78] clause 5.2 (M)

4.4.2.3 Basic Syntax Commands

Refer to [78] clause 5.3 (M)

4.4.2.4 Extended Syntax Commands

Refer to [78] clause 5.4 (M)

4.4.2.5 Issuing Commands

Refer to [78] clause 5.5 (M)

4.4.2.6 Executing Commands

Refer to [78] clause 5.6 (M)

4.4.3.7 MT2 Responses

Refer to [78] clause 5.7 with the exception of DIALTONE and NO ANSWER result codes which are not applicable. (M)

4.4.3 TE-TA interface commands

4.4.3.1 Table 4.4.3 summarizes commands relating to TA-TE interface operation, and a subset of MT2 factory settings:

Command	Clause in [78]	Description	Recommended default value in accordance to [78]	ETCS default value (M)
S2=[<value>]	3.1.2	Escape code character used to switch from Online Data state to Online Command state		S2=128 <i>Escape sequence is disabled</i>
S3=[<value>]	6.2.1	Command line termination character	S3=13	S3=13 ¹¹ <i>Carriage return</i>
S4=[<value>]	6.2.2	Response formatting character	S4=10	S4=10 <i>Line feed¹</i>
E[<value>]	6.2.4	Command echo	E1	E1 <i>Echo enabled</i>
Q[<value>]	6.2.5	Result code suppression	Q0	Q0 <i>TA transmit result codes</i>
V[<value>]	6.2.6	TA response format	V1	V1 <i>DCE transmits full headers and trailers and verbose response text</i>
X[<value>]	6.2.7	Defines CONNECT result code format and dial tone and busy detection		X3 <i>CONNECT is shown with speed; recognition of dialling tone is disabled and busy detection is enabled</i>
&C	6.2.8	Behaviour of circuit 109 DCD. &C0: DCD always on &C1: DCD changes in accordance to the detection of received line signal from the distant end.	&C1	&C1 <i>Circuit 109 changes physical layer functions in accordance with the underlying DCE</i>
&D	6.2.9	Behaviour of circuit 108/2 DTR		&D2 <i>Upon an on-to-off transition of circuit 108/2, the DTE instructs the underlying DCE to perform an orderly clear down of the call</i>

¹ If the command is not supported, MT has to have the predefined factory setting of S3 and S4 according to the ETCS default value specified in the table above. (M)

Command	Clause in [78]	Description	Recommended default value in accordance to [78]	ETCS default value (M)
+IPR=<rate>	6.2.10	specifies the data rate at which the DCE will accept commands	+IPR=0 automatic rate detection	+IPR=XXXX CS-mode refer to 4.4.3.2) PS-mode (refer to 4.4.3.3 – 4.4.3.4)
+ICF=[<format> [,<parity>]] ²	6.2.11	DTE-DCE character framing	+ICF=3,3	+ICF=3,3 <i>Sets 8 data bit, no parity, 1 stop bit</i>
+IFC=[<byte> [,<byte>]] or &K<value>	6.2.12 or Rockwell modem manual	select DTE-DCE flow control mechanism	+IFC=2,2	+IFC=2,2 or &K3 <i>Hardware (based on RTS and CTS) flow control mechanism enabled</i>

Table 4-3 TE-TA interface commands

- 4.4.3.2 Serial line speed of 9600bps shall be used as default value for CS-mode operation. (M)
- 4.4.3.3 PS-mode provides higher transmission bandwidth than CS-mode. The serial line speed should not restrict the performance achieved by the wireless transport system e.g. GPRS/EGPRS. (I)
- 4.4.3.4 Serial line speed of at least 57600 bps shall be used for PS-mode operation. (M)

² If the above command is not supported, MT has to automatically configure “8N1” character framing at the power on. (M)

4.4.4 Result Codes

4.4.4.1 Table 4-4 summarises the most important result codes used over the I_{GSM} interface, in the call control procedures and during the ME status change. For further information please refer to [47]. (I)

Result Code	Applicable to CS-Mode PS-Mode	Description
OK	CS/PS	acknowledges the execution of a command
CONNECT <data rate>	CS/PS	the connection has been established; the MT2 is moving from command state to online data state
RING +CRING: ASYNC [,<priority>[,<subaddr>,<satype>]]	CS	the MT2 has detected an incoming call signal from the network
NO CARRIER	CS/PS	The connection has been terminated The call setup failed before the alerting phase
ERROR +CME ERROR: <err>	CS/PS	The AT command was not accepted
BUSY	CS	The called party is busy: a busy signal has been detected
NO ANSWER	CS	The called party did not answer the call: the connection completion has time-out
+CREG: <stat>	CS	Change in the ME network registration status
+CGREG? <stat>: 0 - not registered, 1 - registered, home network 2 - not registered, but MT is currently trying to attach or searching an operator to register to 3 - registration denied 4 - unknown 5 - registered, roaming	PS	when <n>=1 and there is a change in the MT's GPRS network registration status, If the GPRS MT also supports circuit mode services, the +CREG command and +CREG: result codes apply to the registration status and location information for those services.
+CGATT: <state> 0 - detached 1 - attached Other values are reserved and will result in an ERROR response to the execution command.	PS	Indicates the state of PS attachment
+CGACT? <cid> <state> <state>: indicates the state of PDP context activation 0 - deactivated 1 - activated Other values are reserved and will result in an ERROR response to the execution command.	PS	The test command is used for requesting information on the supported PDP context activation states.
+CGDATA Result codes: CONNECT ERROR	PS	The execution command causes the MT to perform whatever actions are necessary to establish communication between the TE and the network using one or more Packet Domain PDP types.

Table 4-4 Summary of result codes in the mobility management, call control and session management procedures and during the ME status change

4.4.5 CS-Mode Originating Call Establishment

4.4.5.1 Select Bearer Service Type

4.4.5.1.1 The MT2 shall be capable of selecting the GSM-R bearer services used by ETCS application in accordance to [47] sub clause 5.1.4. (M)

4.4.5.1.2 Set command selects the bearer service <name> with data rate <speed> and the connection element for mobile originated calls. (I)

Command	Possible Responses
+CBST=[<speed>[,<name>[,<ce>]]]	OK or ERROR
+CBST?	+CBST: [<speed>[,<name>[,<ce>]]]
+CBST=?	+CBST: (list of supported values)

Table 4-5 CS-mode Bearer Service selection command syntax

4.4.5.1.3 For EuroRadio, the provision of the following values is required: (M)

<speed>:	
70	4800 bps (V.110)

<name>:	
0	asynchronous modem

<ce>:	
0	Transparent

4.4.5.2 Dial Command

4.4.5.2.1 The [47] clause 5.1.2 and the [78] clause 6.3.1 are applicable. (M)

4.4.5.2.2 The Dial command (ATD) instructs the MT2 to originate a call.

Command	Possible Responses
D [<dial_string>]	CONNECT <data rate> NO CARRIER ERROR BUSY OK

Table 4-6 CS-mode Dial up command syntax

4.4.5.2.3 The result code OK will be issued, when the TE aborts a command. The <data rate> specifies the speed of the data connection. Permitted values for <data rate> is:

<data rate>:
4800

4.4.5.3 Select Priority Level

4.4.5.3.1 The priority of a MOC is selected using a Service Code to be put in front of the number to be called, in accordance to [15], Annex B: (M)

Ad*<SC>#<Number>

4.4.5.3.2 Using this command, the priority required for this call is transferred to the GSM-R network by the MT2. (I)

4.4.5.3.3 Use of the extension *<SC># is mandatory. (M)

4.4.5.3.4 When the priority selection is not used, the default priority setting for this subscriber in the network HLR is applied. (I)

4.4.5.3.5 The dial command responses the extended error codes +CME ERROR: <err> are also supported if the MT2 is configured in accordance to [78]. (I)

Defined values:

<SC>:	Priority level:
75	No priority
750	Priority 0
751	Priority 1
752	Priority 2
753	Priority 3
754	Priority 4

4.4.5.3.6 For ETCS only priority 1 is used. For other ERTMS non safety related applications priority 3 is used. (M)

4.4.5.4 Deleted

Table 4-7 Deleted

4.4.6 Deleted

4.4.7 Call Clearing

4.4.7.1 The [78][78] clause 6.3.6 is applicable. (M)

4.4.7.2 The Hook Control (ATH) command instructs the MT2 to clear the call.
(I)

Command	Possible Responses
H[<0>]	OK

Table 4-8 CS-mode Call Clearing command syntax

4.4.8 DTE-DCE interface commands

4.4.8.1 Command Echo

4.4.8.1.1. The [78] clause 6.2.4 is applicable. (M)

4.4.8.1.2 The setting of this parameter determines whether or not the DCE echoes characters received from the DTE. (I)

Command	Possible Responses
E[<value>]	OK or ERROR

Table 4-9 CS-mode Command Echo syntax

Defined values:

0 DCE does not echo characters
1 DCE echoes characters

4.4.8.1.3 Default value: E1

4.4.9 Generic DCE control commands

4.4.9.1 Reset to user default configuration

4.4.9.1.1 The [78] clause 6.1.1 is applicable. (M)

4.4.9.1.2 This command instructs the DCE to set all parameters to their defaults as specified by the user, e.g. in the Non Volatile RAM as user profile. (I)

Command	Possible Responses
Z[<value>]	OK or ERROR

Table 4-10 Reset to default configuration command syntax

Note: The interpretation of <value> is optional and manufacturer-specific. For the use of this command see the remark in the clause below.

4.4.9.2 Set to factory-defined configuration

4.4.9.2.1 The [78] clause 6.1.2 is applicable. (M)

4.4.9.2.2 This command instructs the DCE to set all parameters to default values specified by the manufacturer. (I)

Command	Possible Responses
&F[<value>]	OK or ERROR

Table 4-11 Set to factory configuration syntax

Defined values:

0 Set parameters to factory defaults
(other) Reserved for manufacturer proprietary use.

4.4.9.2.3 Deleted

4.4.10 Network service related commands

4.4.10.1 Subscriber number +CNUM

4.4.10.1.1 The [47] sub clause 5.2.1 is applicable. (M)

4.4.10.1.2 Action command returns the subscriber MSISDN stored in the EF_{MSISDN} in the SIM Card. (I)

4.4.10.2 Network registration +CREG

4.4.10.2.1 The [47] sub clause 5.2.2 is applicable. (M)

4.4.10.2.2 This command enables the presentation of an unsolicited result code +CREG: <stat> when <n>=1 and there is a change in the ME network registration status. (I)

Command	Possible Responses
+CREG[<n>]	
+CREG?	+CREG: <n>, <stat>[,<lac>,<ci>] +CME ERROR: <err>
+CREG=?	+CREG: list of supported <n>s

Table 4-12 CS-mode network service command syntax

Defined values:

<n>:

0: disable network registration unsolicited result code

1: enable network registration unsolicited result code +CREG: <stat>

2: enable network registration and location information unsolicited result code +CREG: <stat>[,<lac>,<ci>]

<stat>:

0 not registered, ME is not currently searching a new operator to register to

1 registered, home network

2 not registered, but ME is currently searching a new operator to register to

3 registration denied

4 unknown

5 registered, roaming

<lac>: string type; two byte location area code in hexadecimal format

<ci>: string type; two byte cell ID in hexadecimal format

4.4.10.2.3 Default values: <n>= 1: in the case that the ME deregisters from the GSM-R network, an unsolicited +CREG: <stat> response is sent to the TE.(M)

4.4.10.3 Operator selection +COPS

4.4.10.3.1 The [47] sub clause 5.2.3 is applicable with the restrictions concerning the modes defined in this specification. (M)

4.4.10.3.2 Set command forces an attempt to select and register the GSM-R network operator: (I)
 <mode> is used to select whether the selection is done automatically by the ME or is forced by this command to operator <oper> (it shall be given in format <format>). In manual mode, if the selected operator is not available, no other operator shall be selected (except <mode>=4). <mode>=2 forces an attempt to deregister from the network. The selected mode affects to all further network registration (e.g. after <mode>=2, ME shall be unregistered until <mode>=0 or 1 is selected).

4.4.10.3.3 The MT2 shall select the last mode used, as the default mode, at every switch-on, as specified in [84] clause 3.2. (M)

Command	Possible Responses
+COPS=[<mode>[,<format> [,<oper>]]]	+CME ERROR: <err>
+COPS?	+COPS: <mode>[,<format>,<oper>] +CME ERROR: <err>
+COPS=?	+COPS: [list of supported (<stat>,long alphanumeric <oper> ,short alphanumeric <oper>,numeric <oper>)s] [.,(list of supported <mode>s),(list of supported <format>s)] +CME ERROR: <err>

Table 4-13 Mobile network operator selection command syntax

Defined values:

<mode>:

- 0 automatic (<oper> field is ignored)
- 1 manual (<oper> field shall be present)
- 2 deregister from network (*)
- 3 set only <format> (for read command +COPS?), do not attempt registration/deregistration (<oper> field is ignored); this value is not applicable in read command response
- 4 manual/automatic (<oper> field shall be present); if manual selection fails, automatic mode (<mode>=0) is entered

<format>:

- 0 long format alphanumeric <oper>
- 1 short format alphanumeric <oper>
- 2 numeric <oper>

<oper>: string type: in accordance to [47] sub clause 5.2.3.³

³ GSM-R Network Codes will be collected by UIC|.

<stat>:
 0 unknown
 1 available
 2 current
 3 forbidden

(*) ETCS application shall be able to work without <mode> 2: deregister from the network.

4.4.10.3.4 Manual (1) and Automatic modes have to be supported by MT. (M)

4.4.10.3.5 Default values: (M)

<mode>: 1 manual
 <format>: 2 numeric

4.4.10.4 Restricted SIM access +CRSM

4.4.10.4.1 The [47] sub clause 5.3.3 is applicable. (M)

4.4.10.4.2 Action command an response allows to create an ordered list comprising MCC/MNC and alphanumeric network names for all networks read from the EF_{GsmrPLMN} in the SIM Card. (I)

4.4.11 Mobile Equipment control and status commands

4.4.11.1 Phone activity status +CPAS

4.4.11.1.1 The [47] sub clause 5.3.6 is applicable with the restrictions defined in this specification. (M)

4.4.11.1.2 Execution command returns the activity status <pas> of the ME. It can be used to interrogate the ME before requesting action from the phone. Refer the [47] sub clause 5.3.6 for possible <err> values. (I)

Command	Possible Responses
+CPAS	+CPAS: <pas> +CME ERROR: <err>
+CPAS=?	+CPAS: [list of supported <pas>s] +CME ERROR: <err>

Table 4-14 Phone Activity status command syntax

Defined values:

<pas>:
 0 ready (ME allows commands from TA/TE) (M)
 1 unavailable (ME does not allow commands from TA/TE) (O)
 2 unknown (ME is not guaranteed to respond to instructions) (O)
 3 ringing (ME is ready for commands from TA/TE, but the ringer is active) (O)
 4 call in progress (ME is ready for commands from TA/TE, but a call is in progress) (O)
 5 asleep (ME is unable to process commands from TA/TE because it is in a low functionality state) (O)

4.4.11.2 Signal quality +CSQ

4.4.11.2.1 The [47] sub clause 5.3.2 is applicable. (M)

4.4.12 Mobile Equipment errors

4.4.12.1 Mobile Equipment errors +CMEE

4.4.12.1.1 The [47] sub clause 5.4 is applicable. (M)

4.4.13 Call control commands and DCE control commands

4.4.13.1 The following table summarises a subset of call and DCE control commands and settings to be stored on the MT2 ETCS default configuration. Any additional commands used will have to comply with [47] (M).

Command	sect. [78]	subcl. [47]	Description	Default ETCS value
D <dial_string>	6.3.1	5.1.2	originates a call	
H[<0>]	6.3.6		hangs-up a call	
S0=[<value>]	6.3.8		sets the number of call indications (rings) required before the call is automatically answered	S0=1 ⁴ <i>ME answers after the first ring</i>
+CBST=[<speed> [, <name> [, <ce>]]]		5.1.4	Selects the bearer service type for mobile originated calls	+CBST=70, 0, 0
Z[<value>]	6.1.1		reset to default configuration	
&F[<value>]	6.1.2		set to factory-defined configuration	
+CRC=<mode>		5.1.7	cellular result codes	+CRC=0 <i>Disabled extended format cellular result codes</i>
+CNUM		5.2.1	returns the MSISDNs related to the subscriber	
+CREG		5.2.2	returns the network registration status	+CREG=1 <i>Enables the network registration status</i>
+COPS[<mode>[, <format> [, <oper>]]]		5.2.3	operator selection	+COPS= =1,2,"<oper>"
+CPAS		5.3.6	returns activity status of MT2	
+CSQ		5.3.2	returns received signal strength indication and channel bit error rate	

⁴ In accordance to [78] clause 6.3.8 recommended default setting for ATSC0 is 0: automatic answer disabled.

Command	sect. [78]	subcl. [47]	Description	Default ETCS value
+CMEE		5.4	enables the use of result code +CME ERROR: <err> as an indication of a ME functionality error	+CMEE=1 <i>Presentation of result code enabled</i>

Table 4-15 Call control commands and DCE control commands

4.5 MT2 Start-up procedure

4.5.1 The MT settings used by ETCS application are listed in Table 4-3 and Table 4-15 of this document.

4.5.2 The GSM-R terminals should be configured with default settings according to the following expected start-up behaviour:

- The radio (MT2) starts automatically when the power is switched on. (M)
- The radio (MT2) shall configure itself to the user stored profile at position “0” (ATZ0). (M)

4.6 PS-Mode

4.6.1 Mobile Class selection +CGCLASS

4.6.1.1 To select the appropriate mobile class “+CGCLASS” command in accordance to [47] clause 6.2.10 shall be used (M):

Command	Possible Response(s)
+CGCLASS=[<class>]	OK ERROR
+CGCLASS?	+CGCLASS:<class>
+CGCLASS=?	+CGCLASS: (list of supported <class>s)

Table 4-16 Mobile Class selection command syntax

4.6.1.2. Following mobile <class> string parameters are applicable considering the mobile mode of operation:

B (M) Class B mode (A/Gb mode)
 MT operates PS and CS services but not simultaneously

4.6.2 ETCS – priority registration

4.6.2.1 The ETCS application and non-ETCS applications can be operated simultaneously (mixed operation). Therefore ETCS requires preferential treatment of radio resource allocation within the radio access domain. For this purpose, control plane signalling need to be controlled in terms of traffic class and guaranteed transmission resource allocation for Uplink and Downlink. (I)

4.6.2.2 The bearer service QoS profile associated with the “etc” APN shall contain the parameter Traffic Class as specified in Table 2-2. (M)

Command	Possible Response(s)
	supported <SDU error ratio>s) , (list of supported <Residual bit error ratio>s) , (list of supported <Delivery of erroneous SDUs>s) , (list of supported <Transfer delay>s) , (list of supported <Traffic handling priority>s) [...]

Table 4-17 Bearer Service QoS parameter command syntax

- 4.6.2.6 For EuroRadio the GPRS/EGPRS bearer service QoS parameters shall be provisioned as specified in Table 2-1 and Table 2-2. (M)
- 4.6.2.7 To verify the negotiated bearer service QoS parameter the command “+CGEQNEG” shall be used. (M)

Command	Possible Response(s)
+CGEQNEG = [<cid> [, <cid> [, ...]]]	+CGEQNEG: <cid>, <Traffic class> , <Maximum bitrate UL>, <Maximum bitrate DL> , <Guaranteed bitrate UL>, <Guaranteed bitrate DL> , <Delivery order> , <Maximum SDU size> , <SDU error ratio> , <Residual bit error ratio> , <Delivery of erroneous SDUs> , <Transfer delay> , <Traffic handling priority> [<CR><LF>+CGEQNEG: <cid>, <Traffic class> , <Maximum bitrate UL>, <Maximum bitrate DL> , <Guaranteed bitrate UL>, <Guaranteed bitrate DL> , <Delivery order> , <Maximum SDU size> , <SDU error ratio> , <Residual bit error ratio> , <Delivery of erroneous SDUs> , <Transfer delay> , <Traffic handling priority> [...]]
+CGEQNEG=?	+CGEQNEG: (list of <cid>s associated with active contexts)

Table 4-18 Bearer Service QoS verification command syntax

- 4.6.2.8 The execution of “+CGCMOD” command can be used to modify the specified PDP context (s) with respect to a changed QoS profile. It requires a change of the QoS parameters using the “+CGEQREQ”. In this case, “+CGEQREQ” command has to be prepended to the “+CGCMOD” command. The QoS profile can’t be changed during ongoing data communication. (I)
- 4.6.2.9 A change of bearer service QoS parameter(s) shall be requested from the network by the command “+CGCMOD” (in accordance to [47] clause 6.2.7) during an active PDP context. (M)

Command	Possible Response(s)
+CGCMOD [= <cid> [, <cid> [, ...]]]	+CME ERROR: <err>
+CGCMOD=?	+CGCMOD: (list of <cid>s associated with active contexts)

Table 4-19 PDP Context modification command syntax

Defined value:
<cid> 1

4.6.3 PS-domain – Network Registration/Deregistration +CGREG, +CGATT, +CGDCONT, +CGACT

- 4.6.3.1 The network registration sequence in case of the GSM CS- and PS-domain can be different depending on the network mode of operation (NMO in accordance to [31]) which is transparent to I_{GSM} interface. (I)
- 4.6.3.2 PS-domain registration comprises the registration towards the applicable mobility management node (e.g. GPRS Attach towards applicable SGSN). The PDP context activation enables the data exchange between the requesting entity (GPRS capable mobile) and the applicable IP packet data network at Gi reference point (in accordance to [31]). (I)
- 4.6.3.3 To be able to monitor and process the different states of GPRS network registration (GPRS Attach), the presentation of unsolicited result codes by the Mobile Termination shall be enabled. (M)
- 4.6.3.4. To enable the GPRS registration unsolicited result code monitoring, the command “+CGREG” in accordance to [47] clause 6.2.12 shall be used. (M)

Command	Possible response(s)
+CGREG= [<n>]	
+CGREG?	+CGREG : <n>, <stat>[, <lac>, <ci>] +CME ERROR: <err>
+CGREG=?	+CGREG: (list of supported <n>s)

Table 4-20 GPRS Network Registration status command syntax

Defined/applicable values are:

- 0 disable network registration unsolicited result code
- 1 enable network registration unsolicited result code
+CGREG: <stat>
- 2 enable network registration and location information
unsolicited result code +CGREG:
<stat>[, <[lac>], <[ci>], <[AcT>], <[rac>]]
- 3 enable network registration, location information and
GMM cause value information unsolicited result code
+CGREG:
<stat>[, <[lac>], <[ci>], <[AcT>], <[rac>] [, <cause_type>, <reject_cause>]]

4.6.3.5 To enable the access towards GSM PS-mode mobility management node (SGSN), the command “+CGATT” in accordance to [47] clause 6.2.4 shall be used (M):

Command	Possible Response(s)
+CGATT=[<state>]	OK ERROR
+CGATT?	+CGATT: <state>
+CGATT=?	+CGATT: (list of supported <state>s)

Table 4-21 GPRS Attach command syntax

4.6.3.6 To enable/disable GSM PS-domain mobility management the states=“0” and “1” shall be used to attach (state=1) and to detach (state=0) from the applicable network node. (M)

4.6.3.7 Deleted

4.6.3.8 To define the packet data protocol (PDP) parameters, the command “+CGDCONT” in accordance to [47] clause 6.2.1 shall be used. (M)

Command	Possible response(s)
+CGDCONT=[<cid> [, <PDP_type> [, <APN> [, <PDP_addr> [, <d_comp> [, <h_comp> [, <pd1> [, ... [, <pdN>]]]]]]]]]	OK ERROR
+CGDCONT?	+CGDCONT: <cid>, <PDP_type>, <APN>, <PDP_addr>, <d_comp>, <h_comp> [, <pd1> [, ... [, <pdN>]]] [<CR><LF>+CGDCONT: <cid>, <PDP_type>, <APN>, <PDP_addr>, <d_comp>, <h_comp> [, <pd1> [, ... [, <pdN>]]] [...]
+CGDCONT=?	+CGDCONT: (range of supported <cid>s) , <PDP_type>, , , (list of supported <d_comp>s) , (list of supported <h_comp>s) [, (list of supported <pd1>s) [, ... [, (list of supported <pdN>s)]]] [<CR><LF>+CGDCONT: (range of supported <cid>s) , <PDP_type>, , , (list of supported <d_comp>s) , (list of supported <h_comp>s) [, (list of supported <pd1>s) [, ... [, (list of supported <pdN>s)]]] [...]

Table 4-22 PDP context configuration command syntax

4.6.3.9 For ETCS operation in PS-mode, the packet data protocol (PDP-context) parameters shall be provisioned as listed in Table 4-23:

“+CGDCONT” parameter in accordance to [47]	Parameter Value	M-mandatory O-Optional	R – requested S - subscribed
<cid>	1	M	R
<PDP_type>	IP	M	R
<APN>	Network Identifier + Operator Identifier etc.s.mncXXX.mccYYY.gprs (see chapter 2.1.3)	M	R
<PDP_addr>	left empty	M	R
<d_comp>	0 (I)	M	R
<h_comp>	0 (I)	M	R

Table 4-23 PDP context parameter settings

Note 1: Any use of compression algorithms between the Mobile Termination and the packet switched core network are for further study.

4.6.3.10 Applicable APN-OI characters, that are required, will be provided by an external source (see clause 2.1.3.14). (I)

4.6.3.11 To enable PS-mode data exchange between the OBU and the applicable RBC, the packet data protocol session (PDP context) shall be established by using the command “APN+CGACT” in accordance to [47] PDP context **ID** - “cid = 1”, that has been declared during PDP context parameter definition (+CGDCONT), shall be used. (M)

Command	Possible Response(s)
+CGACT=[<state> [, <cid> [, <cid> [, ...]]]]	OK ERROR
+CGACT?	+CGACT: <cid>, <state> [<CR><LF>+CGACT: <cid>, <state> [...]]
+CGACT=?	+CGACT: (list of supported <state>s)

Table 4-24 PDP context status command syntax

Applicable PDP context activation states are (<state>):

- 0 - deactivated
- 1 – activated

4.6.3.12 FQDN resolution is described in [5] using Domain Name Service (DNS). (I)

4.6.3.13 The ETCS DNS information (e.g. IP address) shall be associated with the ETCS APN configuration. (M)

4.6.3.14 The EDOR shall obtain the DNS IPv4 information during PDP context activation as part of additional parameters associated with the PDP context in accordance to [33]. (M)

4.6.4 Underlying TE-MT - IP protocol establishment and control

- 4.6.4.1 For the underlying IP protocol establishment and link control TE and MT shall be compliant to [39]. (M)
- 4.6.4.2 For ETCS operation using GPRS/EGPRS bearer service, the PPP – Point to Point Protocol in accordance to [52] shall be used while other protocols are excluded. (M)

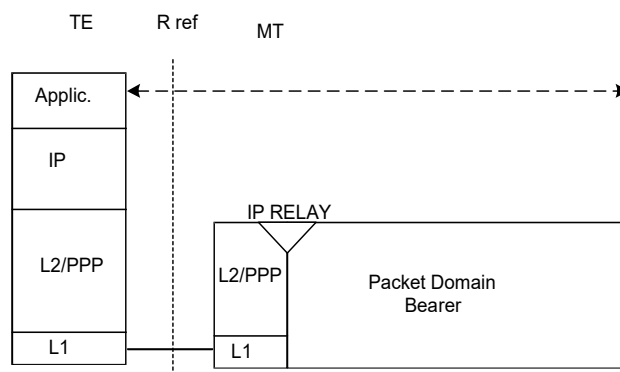

Figure 4-2 PPP based IP communication

- 4.6.4.3 The use of user authentication (CHAP/PAP) as part of the PPP protocol shall be “null” authentication. (M)
- 4.6.4.4 Data encryption between both ends of the PPP link ([60]) shall not be used. (M)
- 4.6.4.5 Data compression between both ends of the PPP link ([59]) shall not be used. (M)
- 4.6.4.6 Link Control Protocol (LCP) and Network Control Protocol (NCP) are necessary constituents of the PPP protocol suite. (I)
- 4.6.4.7 Table 4-25 specifies the applicable LCP protocol configuration parameters (in accordance to [52]) that shall be applied for the ETCS operation:

LCP configuration option (in accordance to [52])	Parameter Support M-Mandatory O-Option	Recommended parameter value for ETCS operation
Maximum-Receive-Unit (MRU) default 1500 octets	M	1500 octets
Authentication-Protocol (PAP/CHAP)	M	N/A
Quality-Protocol (Link Quality Report)	O	N/A
Magic-Number	O	N/A
Protocol-Field-Compression (compressed/uncompressed)	M	N/A

LCP configuration option (in accordance to [52])	Parameter Support M-Mandatory O-Option	Recommended parameter value for ETCS operation
Address-and-Control-Field-Compression	M	N/A
Echo Request	O	N/A
Echo Reply	O	N/A
Restart Timer (default 3 seconds)	M	3
Max-Terminate (default 2 transmission attempts)	M	3
Max-Configure (default 10 transmissions)	M	10
Max Failure (default 5 transmissions)	M	10

Table 4-25 LCP configuration options

4.6.4.8 Table 4-26 specifies the applicable NCP protocol configuration parameters that shall be applied for the ETCS operation (M):

NCP (IPCP) configuration option (in accordance to [51])	Parameter Support M-Mandatory O-Option	Parameter value for ETCS operation	Applicable during ETCS operation Used Not Used
IP-Compression-Protocol (default: no compression enabled)	M	N/A	Not used
IP-Address (incl. DNS server) (Default: IP address is assigned by the network)	M	N/A	Used
Van Jacobson TCP/IP header compression	M	N/A	not used
Compression: Max-Slot-Id	M	To be defined if used	not used
Compression: Comp-Slot-Id	M	To be defined if used	not used

Table 4-26 NCP configuration options

- 4.6.4.9 PDP type IPv4 over PPP shall be supported. (M)
- 4.6.4.10 To resolve the applicable RBC-FQDN into an IP address, the ETCS Domain Name Service as specified in chapter 2.1.3 shall be used. (M)
- 4.6.4.11 For IPv4 any Domain Name Server information shall be delivered as defined in [58]. (M)
- 4.6.4.12 Void
- 4.6.4.13 Void

4.6.4.14 To establish the communication between the TE and the MT, the command “+CGDATA” in accordance to [47] clause 6.2.8 shall be used. (M)

Command	Possible Response(s)
+CGDATA=[<L2P> , [<cid> [, <cid> [, ...]]]]	CONNECT ERROR
+CGDATA=?	+CGDATA: (list of supported <L2P>s)

Table 4-27 CGDATA command syntax

Parameter value <L2P>

“PPP” Point-to-point protocol for a PDP such as IP

Parameter value “cid”:

“1” ETCS APN configuration according to chapter 4.6.3

4.6.4.14i In order to avoid retransmissions or collisions of LCP frames, a guard time is required between the CONNECT reception and the beginning of PPP session. (I)

4.6.4.14ii MT LCP negotiation shall not start before either the guard time of 100 ms is expired in accordance to [78] after transmission of the CONNECT indication, or the incoming “LCP Config Request” is received from TE. (M)

4.6.4.15 The operation of multiple PDP context simultaneously active requires the support of multiple sessions over the R-interface. (I)

4.6.4.16 The multiplexer mode/protocol [38] shall be used to enable simultaneous operation of multiple sessions on the R-interface. (M)

4.6.4.17 Multiple sessions shall comprise the following communication ports:

- at least 2 dedicated ports to be used for ERTMS PS-mode based communication (M)
- 1 shared port to be used ERTMS CS-mode based communication and the control of the Mobile Termination (M)
- 1 dedicated port to be used for control of the Mobile Termination (O)

4.6.4.18 To enable the multiplexer mode, the command “+CMUX” in accordance to [47] clause 6.2.13 shall be applied. (M)

Command	Possible response(s)
+CMUX=<transparency> [, <subset> [, <port_speed> [, <N1> [, <T1> [, <N2> [, <T2> [, <T3> [, <k>]]]]]]]]	+CME ERROR: <err>
+CMUX?	+CMUX: <transparency> [, <subset> [, <port_speed> [, <N1> [, <T1> [, <N2> [, <T2> [, <T3> [, <k>]]]]]]]] +CME ERROR: <err>
+CMUX=?	+CMUX: (list of supported <transparency>s) , (list of supported <subset>s) , (list of supported <port_speed>s) , (list of supported <N1>s) , (list of supported <T1>s) , (list of supported <N2>s) , (list of supported <T2>s) , (list of supported <T3>s) , (list of supported <k>s)

Table 4-28 CMUX command syntax

4.6.4.19 For the operation of ETCS as well as other ERTMS application following specific parameter values for the use of multiplexer mode shall be applied:

Parameter in accordance to [38]	Setting	Requirement
Start-up Mode	Advanced (Note 1)	(M)
Advanced Mode Maximum Frame Size	≥64	(M)
Data Link Connection (DLC) Type of frame during channel operation	UIH	(M)
Convergence layer [1 - 4, default: 1]	2	(M)
Priority [0-63]	ETCS shall always be operated having the highest priority	(M)

Table 4-29 Multiplexer mode – specific parameter values

Note 1: Advanced mode using UI frames.

4.6.4.20 If the multiplexer mode is applied, the multiplexer layer shall be operated in “advanced without error recovery” mode. (M)

4.6.4.21 The application of power saving mode during multiplexer channel operation shall be prohibited. (M)

4.6.4.22 The parameters which are not specifically listed for the operation of the multiplexer mode, for those default settings in accordance to [38] applies. (I)

5 MESSAGE FLOWS

5.1 Deleted

5.2 CS-Mode - Calls Originated from Trainside to Trackside

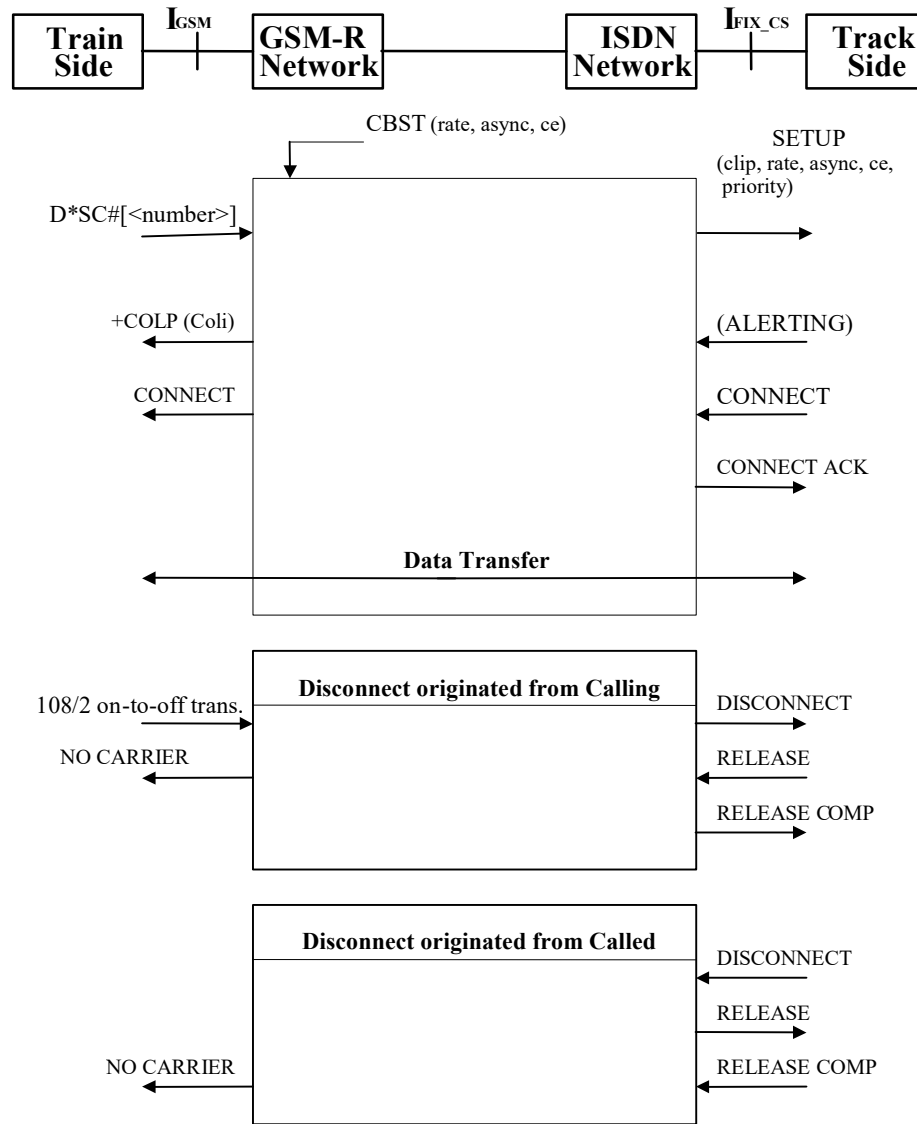

Figure 5-1 MOC message flow

5.2.1 Example: signalling during a CS-mode MOC

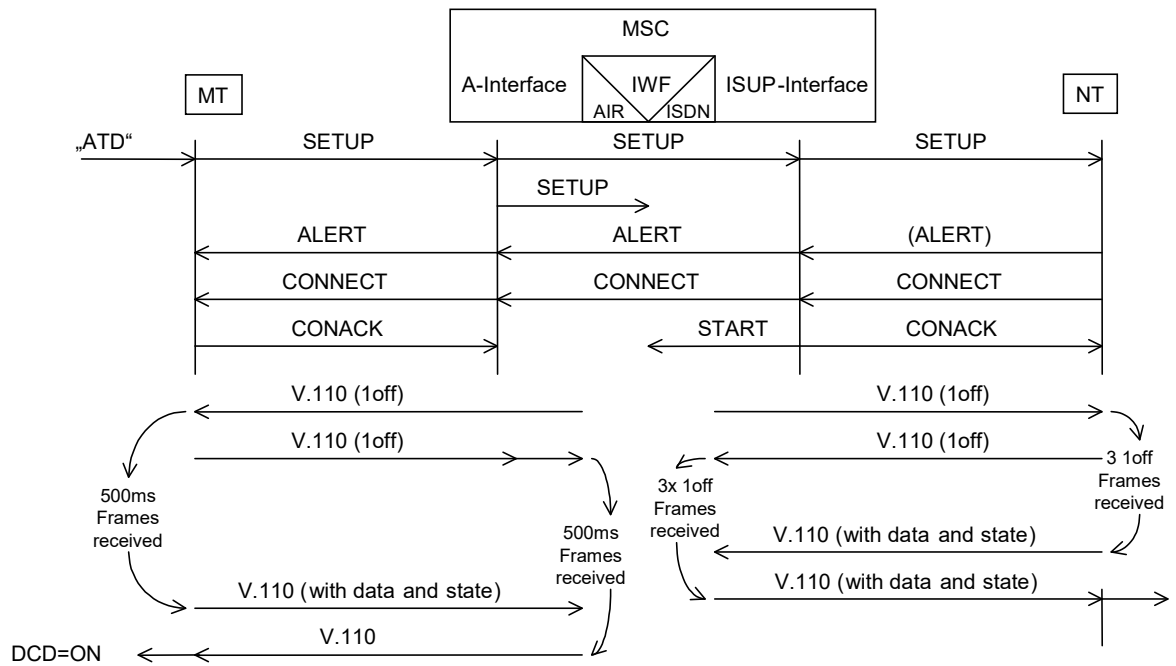

Figure 5-2 Signalling flow during MOC in accordance to [80]

5.3 PS-Mode - GPRS/EGPRS Service Setup (PDN session establishment)

MO PDP context activation including BSS context activation using Packet Flow Context (PFC) (in accordance to [31]).

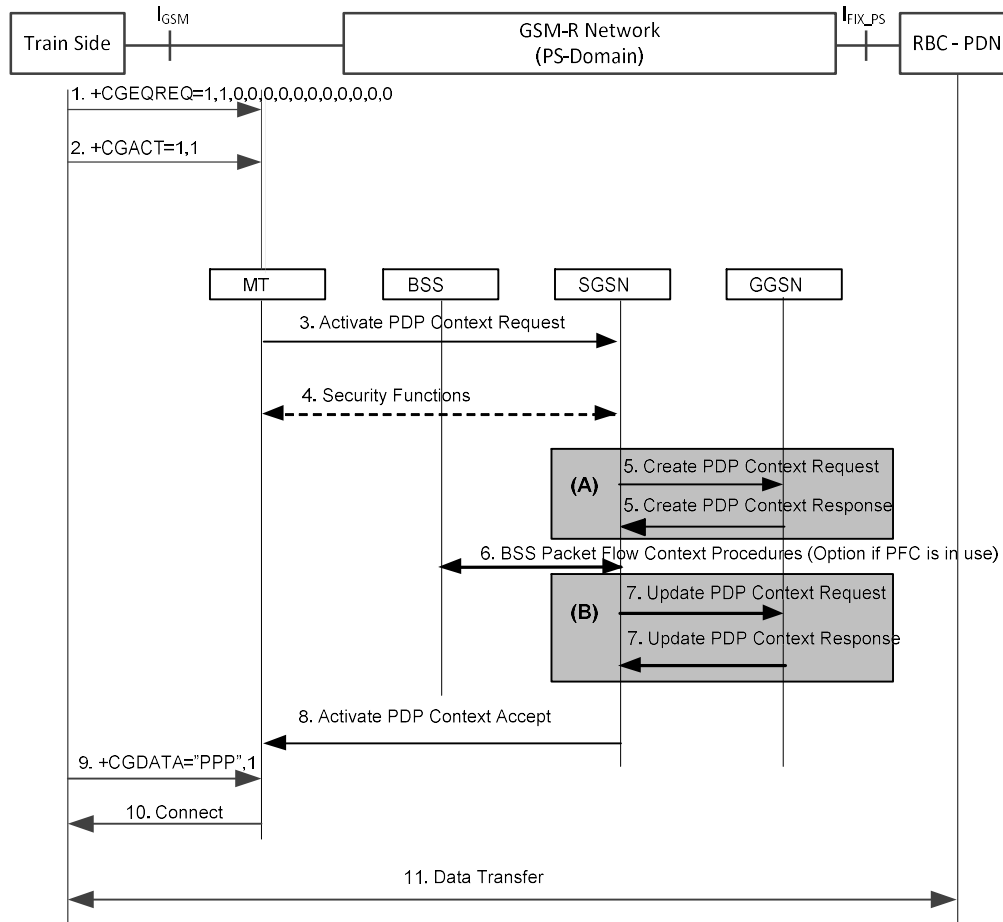

Figure 5-3 PS-mode Signalling Flow during PDP context activation

6 NUMBERING AND ADDRESSING

6.1 CS-mode

- 6.1.1 The numbering plan to be used to address mobile and fixed subscribers of the railway networks is specified in [3] chapter 9. (I)
- 6.1.2 ETCS calls are only Mobile Originated Calls. (I)
- 6.1.3 The EuroRadio application has to provide the called party number of the RBC to be called. (M)
- 6.1.4 The network will perform no special action to handle this kind of call. The number format used to address RBCs connected to the GSM-R network will be either (00+CC+NDC+SN) or using the format (9xx+<RBC/RIU Number>), in accordance to [5i]. The total number length shall not exceed 16 digits. (M)
Note: It is recommended to use the format (00+CC+NDC+SN).
- 6.1.5 The standardized “1500” Short Code can be dedicated to address the call to the appropriate RBC. (I)
- 6.1.6 Deleted

6.2 PS-mode

- 6.2.1 The access addressing (APN) of the RBC-PDN shall be in accordance to the APN structure in [30]. (M)
- 6.2.2 IPv4 addressing comprises a classful network structure in accordance to [48]. (I)
- 6.2.3 IPv4 address space of class A, B or C shall be used for OBU and RBC IP address allocation. (M)
Note: Trackside and train borne equipment may consider international harmonised IPv4 address allocation.
- 6.2.4 The allocation of one IP address to an OBU shall be temporary during an end to end session with the applicable RBC packet data network. (M)
- 6.2.5 The allocation of (a) logical RBC IP address(es) shall be permanent. (M)
- 6.2.6 RBC IP-access redundancy shall be treated inside the applicable packet data network that only one RBC IP-address is propagated to the OBU. (M)
- 6.2.7 The allocation of (a) logical and network interface specific ETCS Domain Name Service entities shall be permanent. (M)
- 6.2.8 ETCS Domain Name Service IP access and entity redundancy shall be treated inside the applicable packet data network that only one ETCS name server IP address is propagated in the PDP context activation response (accept) message (in accordance to [33]). (M)

ANNEX A: SYSTEM ARCHITECTURE

A.0.1 This part of the specification is for information only.

A.1. Overall Architecture

A.1.1 For the transport of the ETCS messages either GSM-R CS-mode or PS-mode is applicable (see Figure A-1). While CS-mode requires a specific ISDN network PS-mode can make use of any IP based transport network to interconnect to the RBC.

In CS-mode control plane signalling is responsible to register/deregister to/from the network and setup/terminate to allocate dedicated transport resources (user plane) in the RBC as well as in the GSM-R- and ISDN network.

EuroRadio is applicable on the network interfaces at the user side ($I_{\text{GSM-R}}$ and $I_{\text{FIX-CS}}$). The interfaces between the networks are controlled by adaptation or interworking functions.

PS-mode control plane signalling enables the Mobility Management (GPRS Attach/Detach) and the data communication between the OBU and the applicable RBC IP data network. Transport resource allocation in the radio access network follows the “On demand” principle. If user data need to be exchanged between the OBU and the RBC, the mobile requests transport resources from the network. The network will allocate resources to the mobile for the time of user data exchange and release them if no further data are received by the mobile (uplink) or network (downlink). Transport resources, i.e. a time slot, can be shared between several users up to the system limit.

EuroRadio is applicable on the network interfaces at the user side (I_{GPRS} and $I_{\text{FIX-PS}}$).

Domain Name Service for ERTMS purposes is associated with the IP packet data network. This particular DNS ensures the resolution of the RBC FQDN into an IP address or informs the OBU about specific ETCS system settings e.g. PS-mode incompatibility of the RBC.

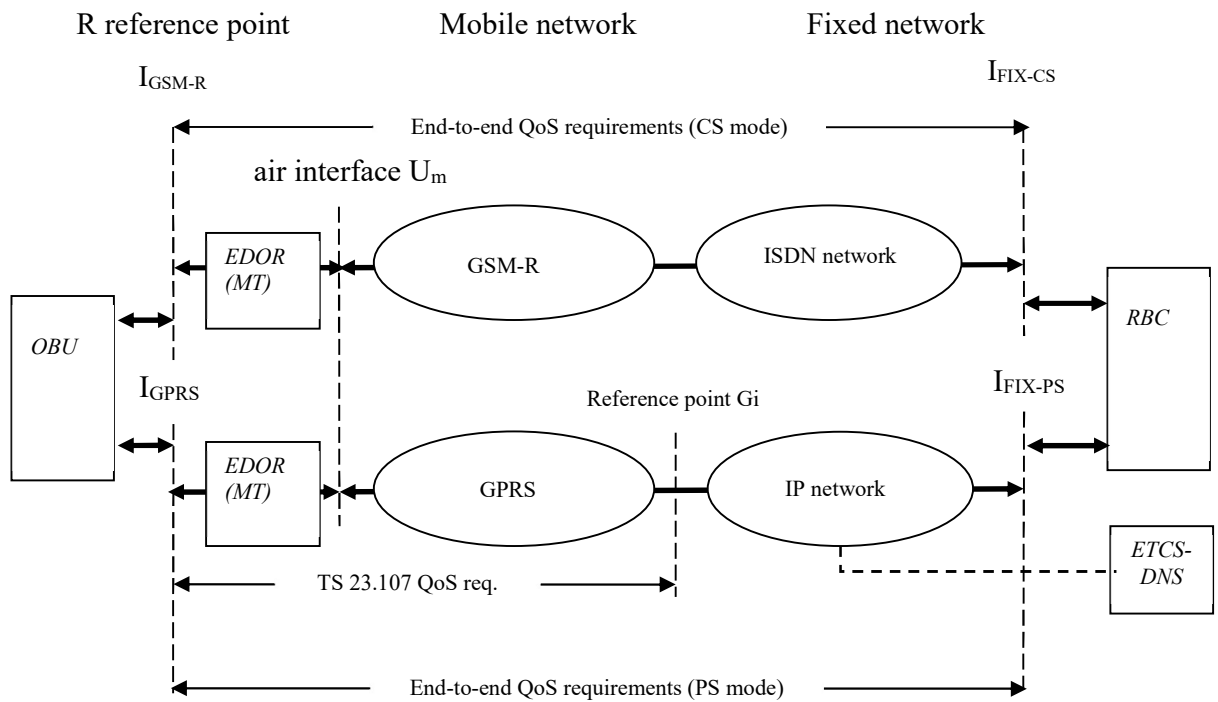

Figure A-1: ERTMS/ETCS CS&PS-mode System Architecture

A.2. GSM-R Network

A.2.0 As shown in Figure A-2, a GSM Public Land Mobile Network (PLMN) consists of the following subsystems:

Access Network

- The Base Station Subsystem (BSS) is the system of base station equipment's (controller, rate adaption etc.), comprising one or more Base Station Controller (BSC), each connected to one or more Base Transceiver Station(s) (BTS);
- The Packet Control Unit (PCU) provides the relevant packet switched GPRS and EGPRS bearer services;

CS-domain:

- Refers to a set of core network entities offering a circuit switched connection for user data traffic. Specific for the CS-domain are the Mobile Switching Centre (MSC), a Gateway MSC (GMSC) and the Visitor Location Register (VLR);

PS-domain:

- Refers to a set of core network entities offering packet switched connection for user data traffic. Specific for the PS-domain are the Serving GPRS Support Node (SGSN) including Location Register; the Gateway GPRS Support Node (GGSN) and the GPRS Name Service (GNS);

Entities common to CS and PS domains

- **Home Location Register-HLR** contains subscription related information to support the network entities in handling CS-mode calls or PS-mode sessions;
- **Authentication Centre-AuC** is associated with an HLR stores the identity key for each mobile subscriber registered with the associated HLR;
- **Equipment Identification Register-EIR** is the logical entity which stores the International Mobile Equipment Identities in the network;

Operation and Maintenance

The Operation and Maintenance Sub-System (OMS) ensures the operation of a telecommunication network with the focus on traffic management e.g. overload, connection outages etc.

In Figure A-2, the connections which carry traffic data are indicated by bold lines (—) whilst those connections carrying only signalling data are indicated by thin lines (—).

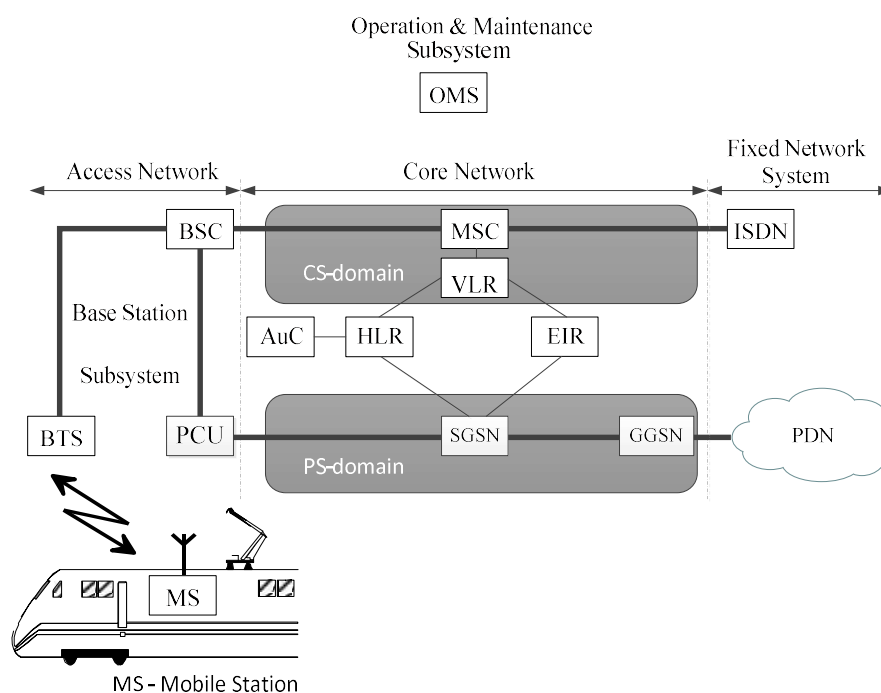

Figure A-2: Mobile network architecture

A.2.1. GSM-R Architecture

A.2.1.1 The GSM network consists of three main elements:

The Mobile Stations (MSs);

The Base Transceiver Station(s) (BTS), the Base Station Controller(s) (BSC), the Packet Control Units constituting the BSS;

The CS-mode Mobile Switching Centre(s) (MSC), the PS-mode Serving GPRS Support Node (SGSN) and the Gateway GPRS Support Node (GGSN)

A.2.1.2 An MSC/SGSN controls one or more BSC/PCU. Each BSC controls one or more BTS. Each BTS controls one cell of the radio network.

A.2.1.3 The MSC and as well the SGSN is (logically) connected to Home Location Registers (HLRs), which contain all the registration data of the subscribers. The HLR is associated with an Authentication Centre (AuC), which contains the security-related information needed for the set-up and ciphering of the connections, in order to prevent unauthorised use of the network. Each MSC/SGSN has a logical connection to a (Visitor)

Location Register (VLR), which keeps track of subscriber mobility inside the registered PLMN.

Optional, a MSC/SGSN can be connected to Equipment Identification Registers (EIRs). These EIRs enable the equipment to be identified, independently of the subscriber using it, in order to detect the use of stolen equipment.

A.2.1.4 In CS-Mode, the MSC and the registers are connected at least logically to form the network subsystem (NSS). The MSC is connected, eventually through an ISDN transport network, to the ETCS trackside network.

A.2.1.5 In GSM PS-mode – SGSN including the Location Register (LR) and GGSN constitute the Packet Core Network that is connected at least logically to the HLR and optionally to an EIR.

A.2.2. GSM-R Terminals

- A.2.2.1 The Mobile Termination have to provide an interface to the EuroRadio module.
- A.2.2.2 A standardised interface has to be provided, in order to ensure the interworking of equipment from different manufacturers.
- A.2.2.3 The [18] specifies the reference points to access the GSM PLMN services and the types of Mobile Termination (MT0, MT1, and MT2). The reference points are conceptual points which divide the functional groups.
- A.2.2.4 The Mobile Termination MT0 means a fully integrated MS. This includes data terminal and adaptation functions which do not support external terminal interfaces. The use of MT0 is out of the scope of this specification and is left for further study.
- A.2.2.5 The Mobile Termination MT1 complies with the GSM recommended subset of the ISDN user-network interface specifications. Bearing in mind the restricted channel capacity of GSM, the ability to support an ISDN interface would not offer any additional functionality. Furthermore, the control of the mobile equipment status and mobile network service (e.g. network selection) is not possible via an ISDN interface. For these reasons, MT1 is no longer considered within this specification.
- A.2.2.6 The Mobile Termination MT2 has to provide an interface that complies with the GSM recommended subset of the ITU-T X or V series interface recommendations. It must provide an appropriate interface protocol to access the GSM PLMN signalling protocols.
- A.2.2.7 The Mobile Termination MT2 can fulfil the requirements for an external interface to the EuroRadio equipment, so MT2 forms the basis of this specification for the EuroRadio / GSM PLMN interface (I_{GSM}).

A.2.3 On board architecture

- A.2.3.1 Seamless RBC area change might require more than one Mobile Termination. The interface specification applies to each individual Mobile Termination. The application must therefore be responsible for the control of these terminals.

A.3. GSM-R CS-mode Network Termination (NT1)

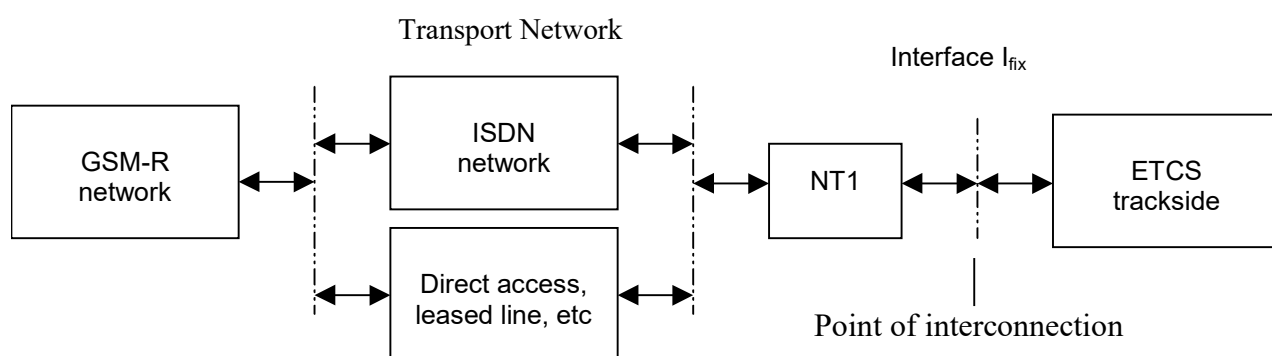

Figure A-3: Fixed side network termination

A.3.0 I_{FIX_CS} is the interface between the GSM-R network terminated by NT1, including, if present, the transport network, and ETCS Trackside. NT1 element includes functions which are broadly equivalent to the physical layer 1 of the OSI reference model. The functions are associated with the proper physical and electromagnetic termination of the network.

NT1 functions are:

- line transmission termination
- layer 1 line maintenance functions and performance monitoring
- timing
- layer 1 multiplexing
- interface termination, including multi-drop termination employing layer 1 contention resolution

A.3.1. ISDN Interface (I_{FIX_CS})

A.3.1.1 The primary rate user-network interface (PRA interface) in accordance to [6] shall be provided.

A.3.1.2 Network terminations of type NT1 shall be supported.

A.3.1.3 Each PRA interface supports 30 B bearer channels and 1 D₆₄ signalling channel. More than one PRA interface can be provided for availability reasons per trackside EuroRadio subsystem.

A.3.1.4 Basic rate access interface and access to PSTN are options not covered by this specification.

ANNEX B: DELETED

ANNEX C: ADDITIONAL INFORMATION ON SIGNALLING TRANSMISSION ON I_{GSM} INTERFACE

C.1.1 Network Registration of Mobile Termination shall comply with the table C1.

Event	MT >	Harmonised behaviour
After power on Previous network available		Initial state: 2 After successful registration: +CREG: 1 or 5
After power on no GSM-R/P coverage		Initial state: 2 Beginning search
After power on Previous/home network not available, other networks available		Initial state: 2 After scanning: +CREG: 4 trying...
Manual registration AT+COPS=1,2,<netID> Requested network available		trying... +CREG: 1 5 3 (in case of CREG state change) OK or ERROR
Manual registration AT+COPS=1,2,<netID> Requested network not available		trying... +CREG: 4 trying...
Aborting in-progress registration		Should be supported. Abort retrieves the previous state (mode and network)
AT commands during in- progress registration		Abort registration
Limited service state (emergency)		+CREG: 3 if MRM rejected by network. +CREG: 4 if selected network not found.
Location Update reject		+CREG: 3

Table C1: Related AT Commands

END OF DOCUMENT.

Published by:
International Union of Railways (UIC) - Railway Technical Publications (ETF)
16, rue Jean Rey 75015 Paris - France

March 2022
Copyright deposit: March 2022

ISBN 978-2-7461-3121-7