

ERTMS/ETCS

FIS for the RBC/RBC Handover

REF : SUBSET-039

ISSUE : 3.1.0

DATE : 09-05-2014

Company	Technical Approval	Management approval
ALSTOM		
ANSALDO		
AZD		
BOMBARDIER		
CAF		
SIEMENS		
THALES		

1. MODIFICATION HISTORY

Issue Number Date	Section Number	Modification / Description	Author
0.0.1 990902	All	Document creation	OG
1.0.0 991014	Version number	Release version	HE
1.0.1 000203	See revision marks	Updated to be compliant with SRS class 1 v2.0.0	OG
1.0.2 000314	See revision marks	Train characteristics for route suitability removed from "Preannouncement" message	OG
2.0.0 000330		Final issue to ECSAG	U.D. (ed)..
Version 2.1.0 (16-June-2005)	all	Draft enhancements by WP RBC HOV FIS	LK
Version 2.1.1 (11-AUG-2005)	3.2.1.1, 6.3.1.1	Subset-108 added, Packet 88 deleted	LK
Version 2.1.2 (31-AUG-2005)		Modifications acc. To email comments	LK
Version 2.2.9 (11-Feb-2009)	all	Consistency with SRS 2.3.0 and Subset-108 v1.2.0	WP RBC/RBC Handover
Version 2.2.10 (17-March-2009)	B.1.1.1 6.2.1.1 5.1.1.1, 5.1.1.2, 5.1.1.3 Table 9, 5.3.1.3 6.3.1.2 6.3.4.1 6.2.4.2, 6.6.1.22 6.6.1.3 3.2.1.1	Amendments based on comments from EEIG Users Group during a joint meeting on 11-March-2009	WP RBC/RBC Handover
Version 2.2.11 (27-March-2009)	3.2 Table 9 6.6.1.5	Amendments based on comments received from ERA, e-mail 18-March-2009.	WP RBC/RBC Handover

Issue Number Date	Section Number	Modification / Description	Author
	B.1.1.1	Editorial update in Table 9.	
Version 2.3.0 (7-April-2009)		Version 2.3.0 created for official release after Unisig SC approval. No change in the contents.	WP RBC/RBC Handover
Version 3.0.0 (2-Dec-2010)		Consistency of Subset-039 with SRS 3.1.0.	WP RBC/RBC Handover
Version 3.0.1 (29-Apr-2011)		Consistency of Subset-039 with SRS 3.2.0.	WP RBC/RBC Handover
Version 3.0.2 (09-Dec-2011)		Update based on review comments, elaborating Backwards Compatibility	WP RBC/RBC Handover
Version 3.0.3 (10-Feb-2012)		Update based on review of version 3.0.2	WP RBC/RBC Handover
Version 3.0.4 (10-Aug-2012)		Update based on review of version 3.0.3 and Workshop WP+SG+ERA	WP RBC/RBC Handover
Version 3.0.5 (30-Oct-2012)		Updated based on CR1088 as well as CR413, CR459, CR535, CR637, CR656, CR676, CR731, CR745, CR757, CR809, CR1133, CR1135 and CR1140. Updated based on review of version 3.0.4.	WP RBC/RBC Handover
Version 3.0.6		UNISIG internal version	WP RBC/RBC Handover
Version 3.0.7		UNISIG internal version	WP RBC/RBC Handover
Version 3.0.8 (16-Oct-2013)		Updated based on: - CR1088 including ERA comments of entry 24/09/13 and Super Group comments of entry 24/09/13. - CR1143, CR1159 and CR1168.	UNISIG



Issue Number Date	Section Number	Modification / Description	Author
Version 3.0.9		Update based on principles retained in CG meeting 06/02/14	ERA
Version 3.0.10 (15-Apr-2014)		Updated to incorporate all review comments and editorial corrections	UNISIG
Version 3.0.11 (24-Apr-2014)	3.3	Update to incorporate ERA comment about removing TSR and LX Baseline 3 1 st Maintenance pre-release version	UNISIG
3.1.0 09/05/14	-	Baseline 3 1 st Maintenance release version	PP



2. TABLE OF CONTENTS

1. MODIFICATION HISTORY	2
2. TABLE OF CONTENTS.....	5
3. INTRODUCTION.....	7
3.1 Scope and Purpose.....	7
3.2 References	7
3.3 Terms and Abbreviations	7
4. RBC/RBC HANDOVER.....	9
4.1 Overview.....	9
4.2 RBC/RBC Communication	9
4.3 RBC/RBC Handover Transaction.....	10
4.4 RBC/RBC Communication Supervision.....	11
4.5 RBC/RBC Handover Task Description	11
4.5.1 Handing Over RBC	11
4.5.2 Accepting RBC.....	12
4.6 State Tables.....	13
4.6.1 General.....	13
4.6.2 State Table of Handing Over RBC	14
4.6.3 State Table of Accepting RBC.....	17
4.6.4 State Table for Communication Supervision	21
4.7 Configuration Management.....	23
5. MESSAGES	24
5.1 General.....	24
5.2 Messages from the Handing Over RBC to the Accepting RBC.....	26
5.2.1 Pre-Announcement.....	26
5.2.2 Route Related Information Request	26
5.2.3 Announcement.....	28
5.2.4 RRI Confirmation	28
5.2.5 Train Data.....	29
5.2.6 Train Running Number.....	29
5.3 Messages from the Accepting RBC to the Handing Over RBC.....	30
5.3.1 Route Related Information	30
5.3.2 Taking Over Responsibility.....	31
5.3.3 Request for RRI Confirmation	32
5.4 Messages from both Accepting RBC or Handing Over RBC	32



5.4.1	Acknowledgement.....	32
5.4.2	Cancellation	33
5.4.3	Life Sign.....	33
5.5	Packets.....	33
5.6	Variables.....	34
6.	MANAGEMENT OF OLDER SYSTEM VERSIONS.....	41
6.1	Scope.....	41
6.2	General Requirements	42
6.3	Exceptions to Chapter 4.....	42
6.4	Exceptions to Chapter 5.....	43
6.5	Additional Requirements for an RBC X=2 Communicating with an RBC X=1	47
6.5.1	General.....	47
6.5.2	T1: Information Received by RBC _{ACC} X=2 from RBC _{HOV} X=1	48
6.5.3	T2: Information Sent by RBC _{ACC} X=2 to RBC _{HOV} X=1	49
6.5.4	T3: Information Sent by RBC _{HOV} X=2 to RBC _{ACC} X=1.....	52
6.5.5	T4: Information Received by RBC _{HOV} X=2 from RBC _{ACC} X=1	54
6.6	Additional Requirements when System Version 1.1 is Applicable for the Interface.....	57
ANNEX A	– (INFORMATIVE) RBC/RBC COMMUNICATION	59
A.1	The RBC/RBC Communication Model.....	59
A.2	Initialisation of RBC/RBC Communication.....	59
A.3	Data Transfer	60
A.4	Example of Message Sequence.....	61
A.5	Example of Life Sign	62
A.6	Error Handling.....	63
ANNEX B	– INTERFACE DETAILS FOR RBC X=1	64
B.1	State Table of Handing Over RBC	64
B.2	State Table of Accepting RBC.....	67
B.3	Example of X=1 Life Sign.....	71

3. INTRODUCTION

3.1 Scope and Purpose

- 3.1.1.1 This document specifies the functional interface for the RBC/RBC communication to perform an RBC/RBC handover according to the principles and procedures in the SRS [Subset-026].
- 3.1.1.2 The purpose of this specification is to enable any pair of neighbouring RBCs compliant with it to be interconnected so that RBC/RBC handovers can be performed, independently of the functional characteristics, service performance and safety of the concerned RBCs, which are outside the scope of this specification.

3.2 References

- 3.2.1.1 The following documents are referenced in this document

Reference	Title
Subset-023	Glossary of Terms and Abbreviations
Subset-026	System Requirements Specification
Subset-035	Specific Transmission Module FFFIS
Subset-040	Dimensioning and Engineering rules
Subset-098	RBC-RBC Safe Communication Interface

3.3 Terms and Abbreviations

- 3.3.1.1 For general terms and abbreviations refer to [Subset-023]. Additional terms and abbreviations relevant for RBC/RBC handover and used in this document are specified here.

Term	Definition
EoA interval	Part of track from one EoA/LoA location to the next EoA/LoA location, as defined by the trackside design
NRBC message	Message sent to or received from a neighbour RBC
RBC/RBC communication entity	An application entity responsible for RBC/RBC handover protocol handling, for one or more handovers depending on implementation



Term	Definition
RBC/RBC handover protocol	The protocol for information exchange between RBCs, to support the RBC/RBC handover.
RBC/RBC handover transaction	The sequence of (NRBC) messages between RBCs to support the passing of an engine from one RBC to an adjacent RBC (neighbour RBC).

Abbreviation	Definition
ACC	Accepting
BG	Balise group
ETCS ID	ETCS Identity
HOV	Handover
N/A	Not applicable
NRBC	Neighbour RBC
RBC _{ACC}	Accepting RBC
RBC _{HOV}	Handing Over RBC
RRI	Route Related Information
SAP	Service access point
TOR	Taking Over Responsibility

4. RBC/RBC HANDOVER

4.1 Overview

- 4.1.1.1 For an efficient handover, communication between two radio block centres is required when a train is about to move from one radio block centre supervision area to the adjacent one (Figure 1).
- 4.1.1.2 This communication consists of NRBC (Neighbour RBC) messages as specified in chapter 5.

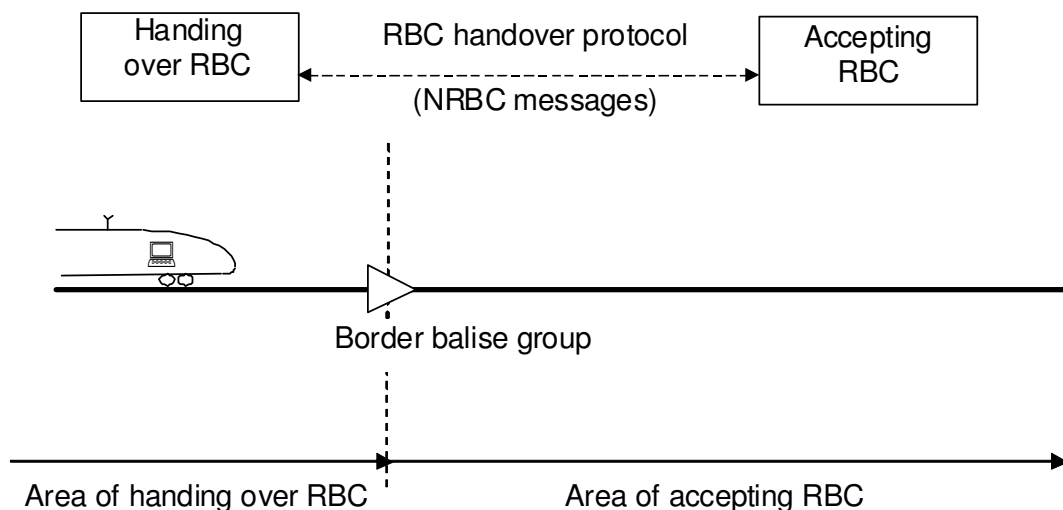

Figure 1: RBC/RBC Handover

- 4.1.1.3 Section 4.5 describes the communication of the RBCs during Handover. To make the section more readable requirements which are defined in the SRS are expressed as responsibilities. Additional requirements to those in the SRS are defined when needed.
- 4.1.1.4 Because new functionalities for system version X=2 have been included in Subset-039 and the language has been changed, the handover communication with an RBC operating with an older system version is defined in chapter 6 “Management of Older System Versions”.

4.2 RBC/RBC Communication

- 4.2.1.1 The RBC/RBC communication shall be established according to the rules of the underlying RBC-RBC Safe Communication Interface [Subset-098]. Further information about RBC/RBC communication can be found in Annex A.
- 4.2.1.2 Only one RBC/RBC communication between a pair of RBCs shall be active at one time.

- 4.2.1.3 Note: One RBC/RBC communication is able to handle all necessary handover transactions between a pair of RBCs.
- 4.2.1.4 The RBC/RBC communication shall provide for the exchange of NRBC messages (as specified in chapter 5) in both directions simultaneously, i.e. the RBC/RBC HOV transaction(s).
- 4.2.1.5 The RBC/RBC communication entities of Handing Over RBC and Accepting RBC are identified by their ETCS ID.

4.3 RBC/RBC Handover Transaction

- 4.3.1.1 The RBC/RBC HOV transaction is identified by the ETCS ID of the engine and the ETCS ID of the border balise group.
 - 4.3.1.1.1 Note: In case of more than one communicating engine in a train each engine has its own RBC/RBC handover transaction.
 - 4.3.1.2 It shall be possible for an RBC to act as the Accepting and as the Handing Over RBC for different engines at different RBC border locations simultaneously.
 - 4.3.1.3 The RBC shall be able to handle RBC/RBC handover transactions which,
 - a) follow each other (i.e. the first RBC/RBC HOV transaction is finished before the second starts),
 - b) overlap (i.e. RBC/RBC HOV transactions are handled simultaneously),
 - c) overlap with inverted roles of RBCs,
 - d) are cancelled without an engine being handed over.
 - 4.3.1.4 When the Accepting RBC receives a pre-announcement message for a transaction after the first RRI Request message, it shall consider this as a cancellation condition for the already on-going transaction.
 - 4.3.1.4.1 Note: the new pre-announcement may indicate that a cancellation was missed by the Accepting RBC or that a loss of communication was not recognised by the Accepting RBC.
 - 4.3.1.4.2 Note: A cancellation condition will cause the Accepting RBC to send a cancellation message which cancels any transaction on-going for the specified engine in the Cancellation message.
 - 4.3.1.5 When the Accepting RBC receives a pre-announcement message with the same engine identity and a different border balise group as another on-going transaction it shall consider this as a cancellation condition for the transactions with that engine identity.
 - 4.3.1.6 When the Accepting RBC receives a pre-announcement message with the same border balise group and a different engine identity as another on-going transaction it shall consider this as a cancellation condition for the transactions with that border balise group if more than one of the engines (including the newly pre-announced one) has been pre-announced with a mode other than Non Leading mode.



4.3.1.7 When the Accepting RBC receives a pre-announcement message which is considered as a cancellation condition, this pre-announcement message shall not be used to establish a new transaction.

4.3.1.8 The Accepting RBC shall not send Route Related Information before receiving the first RRI Request message.

4.4 RBC/RBC Communication Supervision

4.4.1.1 The ability for a pair of neighbouring RBCs to communicate shall be supervised after the establishment of a safe connection and for as long as this safe connection exists, see also section 4.6.4.

4.4.1.2 If the safe connection between the RBCs is lost (e.g. by an error in the lower layers):

- a) Re-establishment of the safe connection shall be requested by the RBC responsible for this task (see Table 13, list item 2)
- b) The RBC/RBC communication shall be regarded as lost.

4.4.1.3 If the communication between the RBCs is lost:

- a) Any ongoing handover transaction shall be aborted.
- b) If at this instance a safe connection between RBCs still exists it shall be terminated and regarded as lost.

4.4.1.4 If the RBC/RBC communication is lost during an ongoing RBC/RBC handover transaction, each RBC shall take any further necessary action according to its own rules.

4.4.1.5 After establishment of a safe connection the communication shall be regarded as established and each RBC shall send a (first) Life Sign message.

4.4.1.6 Each RBC shall send an appropriate NRBC message before a specified time has passed since any NRBC message was sent. Without an ongoing handover transaction or when no other message has to be sent in an ongoing transaction the Life Sign message shall be used for this purpose.

4.4.1.7 An RBC shall consider the RBC/RBC communication lost if no consistent NRBC message has been received within a specified time (see Table 13, list item 6) since reception of the last consistent message (see section 5.1).

4.4.1.7.1 Note: The RBCs might not detect loss of RBC/RBC communication at the same time.

4.5 RBC/RBC Handover Task Description

4.5.1 Handing Over RBC

4.5.1.1 The Handing Over RBC is responsible to send information about an approaching train to the Accepting RBC area (i.e. pre-announcement).

- 4.5.1.2 The Handing Over RBC is responsible to request route related information when necessary, i.e. for efficient handover when a train is moving towards a border, and is allowed to limit the amount of route related information to be received.
- 4.5.1.3 The Handing Over RBC is responsible to forward route related information received from the Accepting RBC to the relevant ETCS on-board equipment.
- 4.5.1.4 In case the Accepting RBC requests a confirmation for route related information containing a shortened MA, the Handing Over RBC shall send a positive confirmation when the train is able to stop before the new end of authority.
 - 4.5.1.4.1 Note: A negative confirmation means that the train may not be able to stop before the new end of movement authority.
 - 4.5.1.4.2 Note: It is the responsibility of the RBC_{HOV} how to handle the contained shortened MA towards the on-board, for example by co-operative shortening of the MA or a shortened MA.
- 4.5.1.5 The Handing Over RBC is responsible to cancel a transition to the Accepting RBC when necessary.
- 4.5.1.6 The Handing Over RBC shall forward train data to the Accepting RBC during an ongoing handover transaction when received from the related ETCS on-board equipment.
- 4.5.1.7 The Handing Over RBC shall forward the train running number to the Accepting RBC during an ongoing handover transaction, when received from or sent to the related ETCS on-board equipment.
- 4.5.1.8 The Handing Over RBC is responsible to take an appropriate action (e.g. message repetition) if a requested acknowledgement is not received from the Accepting RBC as expected.

4.5.2 Accepting RBC

- 4.5.2.1 After the acknowledgement of pre-announcement from the Handing Over RBC, the Accepting RBC is allowed to send route related information to the Handing Over RBC.
- 4.5.2.2 The Accepting RBC is responsible to send route related information as often as necessary, according to its own rules.
 - 4.5.2.2.1 Note: The Accepting RBC assumes that any route related information sent to the Handing Over RBC will be forwarded to the relevant ETCS on-board equipment, according to the rules of the Handing Over RBC.
- 4.5.2.3 The Accepting RBC is responsible to limit the route related information according to the last received route related information request if one has been received.
- 4.5.2.4 The Accepting RBC shall only send route related information containing a shortened MA with request for confirmation, after at least one route related information was sent to the RBC_{HOV} and this message has been acknowledged.



- 4.5.2.5 The Accepting RBC is responsible to base any route related information it sends on the last train data received from the on-board. In case no train data has been received from the on-board, the Accepting RBC is responsible to base any route related information it sends on the last train data received from the Handing Over RBC.
- 4.5.2.6 After acknowledging new train data received from the Handing Over RBC and if any Route Related Information (RRI) has previously been sent, the Accepting RBC shall immediately send RRI.
- 4.5.2.7 The Accepting RBC is responsible to send a Taking over responsibility message after the condition “border passed” is detected (see Table 6).
- 4.5.2.8 The Accepting RBC is allowed to cancel an RBC-RBC handover transaction when necessary.
- 4.5.2.9 The Accepting RBC is responsible to take an appropriate action (e.g. message repetition) if a requested acknowledgement is not received from the Handing Over RBC as expected.

4.6 State Tables

4.6.1 General

- 4.6.1.1 Without restriction to the implementation of the internal RBC behaviour this section 4.6 formally describes the communication required to support an RBC/RBC handover transaction. The RBC shall conform to the external behaviour at the RBC/RBC interface.
- 4.6.1.2 The description of the data exchange at the RBC/RBC interface is given by state transition tables, which show the states of an RBC/RBC communication entity, the incoming events, the actions taken and the resultant states.
- 4.6.1.3 At each intersection of state and incoming event a state transition table specifies a transition which may include actions, consisting of a list of outgoing events (none, one, or more), followed by the resulting state.
- 4.6.1.4 If the intersection of state and incoming event is left blank then the incoming event is invalid in the respective state. In this case an error notification may be given (implementation matter) and the state remains unchanged.
- 4.6.1.5 Note:
 - a) The actions to build a NRBC message before sending are not shown in the state transition table.
 - b) The consistency checks of a received NRBC message and - in case of an error - the resulting actions are not shown in the state transition table.
- 4.6.1.6 All events, which indicate the reception of a NRBC message implicitly, include checking that the message is consistent.

4.6.2 State Table of Handing Over RBC

4.6.2.1 The following states are defined for one RBC/RBC handover transaction.

Table 1 States of Handing Over RBC

State	Description
IDLE	No RBC/RBC handover is in progress
HOV	An RBC/RBC handover is on-going. The RBC has the role of Handing Over RBC.

4.6.2.2 The following table specifies the incoming events.

Table 2 Incoming Events of Handing Over RBC

Event	Description
HOV condition detected	Handover condition detected
RRI request necessary	Handing Over RBC detects that route related information is required from the Accepting RBC
RRI received	NRBC message "Route Related Information" received
Condition "Border passed by safe front end" detected	Position report received and condition "Border passed by maximum safe front end" detected
TOR received	NRBC message "Taking Over Responsibility" received
Condition "Border passed by safe rear end" detected	Position report received and condition "Border passed by minimum safe rear end" detected
Cancellation condition detected	Condition for cancellation of the RBC/RBC handover transaction is detected in the Handing Over RBC
ACK received	NRBC message "Acknowledgement" has been received
Cancellation received	NRBC message "Cancellation" received
Request for RRI Confirmation received	NRBC message "Request for RRI Confirmation" received
RRI Confirmation condition detected	RRI Confirmation condition detected
New train data received	The Handing Over RBC has received new train data from the ETCS on-board equipment
New train running number received	The Handing Over RBC has received a new train running number from the ETCS on-board equipment

Event	Description
New train running number given	The Handing Over RBC has given a new train running number to the ETCS on-board equipment, i.e. it is assumed that the on-board is now using a new number

4.6.2.3 The following table specifies the outgoing events.

Table 3 Outgoing Events of Handing Over RBC

Event	Description
Pre-Announcement	Send NRBC message "Pre-Announcement"
RRI request	Send NRBC message "Route Related Information Request"
ACK	Send NRBC message "Acknowledgement"
Announcement	Send NRBC message "Announcement"
Cancellation	Send NRBC message "Cancellation"
RRI Confirmation	Send NRBC message "RRI Confirmation"
New train data	Send NRBC message "Train Data"
New train running number	Send NRBC message "Train Running Number"

4.6.2.4 The following figure shows the state diagram of the Handing Over RBC:

- a) The states (refer to Table 1)
- b) The incoming events (refer to Table 2)
- c) The state transitions.

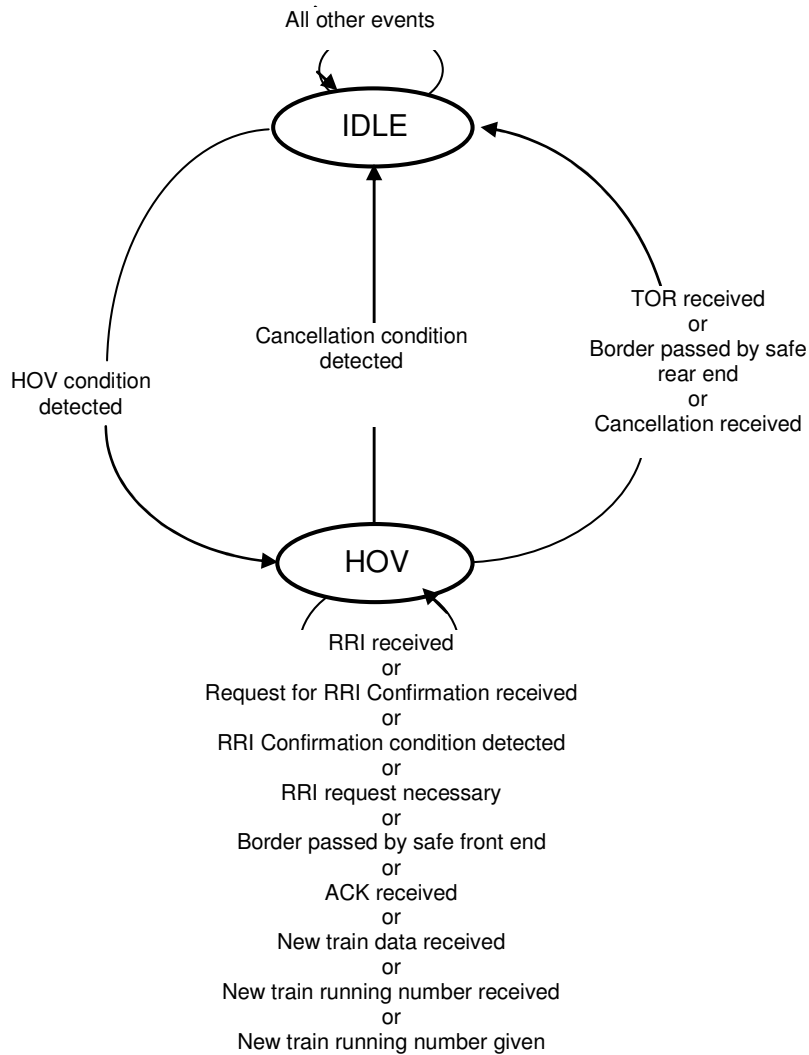

Figure 2 Handing Over RBC State Diagram

4.6.2.5 For each state (see Figure 2) the following table defines for each incoming event what has to happen and which is the next state.

Table 4 Handing Over RBC State Transition Table

Event	IDLE	HOV
HOV condition detected	Send "Pre-Announcement" → HOV	
RRI request necessary		Send "RRI request" → HOV
RRI received	→ IDLE	Send "Acknowledgement" → HOV
Condition "Border passed by safe front end"	→ IDLE	Send "Announcement" → HOV

Event	IDLE	HOV
TOR received	→ IDLE	→ IDLE
Condition "Border passed by safe rear end"	→ IDLE	→ IDLE
Cancellation condition detected	see Note below this table	Send "Cancellation" → IDLE
ACK received	→ IDLE	→ HOV
Cancellation received	If M_ACK=1: Send "Acknowledgement" → IDLE If M_ACK=0 → IDLE	If M_ACK=1: Send "Acknowledgement" → IDLE If M_ACK=0 → IDLE
Request for RRI Confirmation received	→ IDLE	Send "Acknowledgement" → HOV
RRI Confirmation condition detected		Send "RRI Confirmation" → HOV
New train data received	→ IDLE	Send "Train Data" → HOV
New train running number received	→ IDLE	Send "Train Running Number" → HOV
New train running number given	→ IDLE	Send "Train Running Number" → HOV

4.6.2.6 Note: Cancellation may be repeated, e.g. if acknowledgement was not received.

4.6.3 State Table of Accepting RBC

4.6.3.1 The following states are defined for one RBC/RBC handover transaction.

Table 5 States of Accepting RBC

State	Description
IDLE	No RBC/RBC handover is in progress
ACC	An RBC/RBC handover is ongoing. The RBC has the role of Accepting RBC.

4.6.3.2 The following table specifies the incoming events.

Table 6 Incoming Events of Accepting RBC

Event	Description
Pre-Announcement received	NRBC message "Pre-Announcement" received
RBC decided to send RRI	Accepting RBC has decided (e.g. Signalling environment has changed) to send NRBC message "Route Related Information"
RRI request received	NRBC message "Route Related Information Request" received
ACK received	NRBC message "Acknowledgement" received
Announcement received	NRBC message "Announcement" received
Condition "Border passed by safe front end" detected	Position report received and condition "Border passed by maximum safe front end" detected
Cancellation received	NRBC message "Cancellation" received
Cancellation condition detected	Condition for cancellation of the RBC/RBC handover transaction is detected in the Accepting RBC
RBC decided to send Request for RRI Confirmation	Accepting RBC has decided to send NRBC message "Request for RRI Confirmation"
RRI Confirmation received	NRBC message "RRI Confirmation" received
New train data received	NRBC message "Train Data" received
New train running number received	NRBC message "Train Running Number" received

4.6.3.3 The following table specifies the outgoing events.

Table 7 Outgoing Events of Accepting RBC

Event	Description
RRI	Send NRBC message "Route Related information"
TOR	Send NRBC message "Taking over Responsibility"
ACK	Send NRBC message "Acknowledgement"
Cancellation	Send NRBC message "Cancellation"

Event	Description
Request for RRI Confirmation	Send NRBC message "Request for RRI Confirmation"

4.6.3.4 The following figure shows the state diagram of the Accepting RBC.

- a) The states (refer to Table 5)
- b) The incoming events (refer to Table 6)
- c) The state transitions

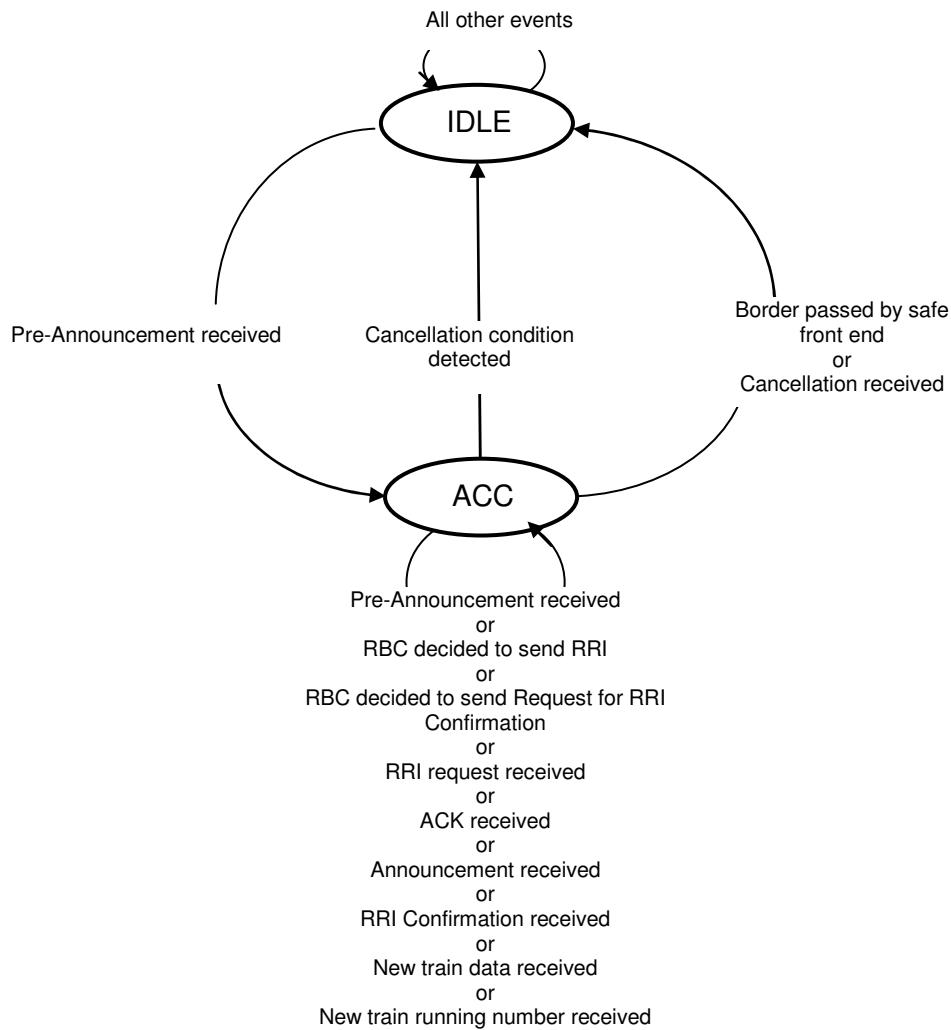

Figure 3 Accepting RBC State Diagram

4.6.3.5 For each state (see Figure 3) the following table defines for each incoming event, what has to happen and which is the next state.

Table 8 Accepting RBC State Transition Table

Event	IDLE	ACC
Pre-Announcement received	Send "Acknowledgement" → ACC	Send "Acknowledgement" → ACC
RBC decided to send RRI		Send "RRI" → ACC
RRI request received		If M_ACK=1: Send "Acknowledgement" → ACC If M_ACK=0: → ACC
ACK received	→ IDLE	→ ACC
Announcement received	→ IDLE	If M_ACK=1: Send "Acknowledgement" → ACC If M_ACK=0: → ACC
Condition "Border passed by safe front end"	→ IDLE	Send "TOR" → IDLE
Cancellation received	If M_ACK=1: Send "Acknowledgement" → IDLE If M_ACK=0: → IDLE	If M_ACK=1: Send "Acknowledgement" → IDLE If M_ACK=0: → IDLE
Cancellation condition detected	see Note below this table	Send "Cancellation" → IDLE
RBC decided to send Request for RRI Confirmation		Send "Request for RRI Confirmation" → ACC
RRI Confirmation received	→ IDLE	If M_ACK=1: Send "Acknowledgement" → ACC If M_ACK=0: → ACC
New Train Data received	→ IDLE	Send "Acknowledgement" Send "RRI" → ACC

Event	IDLE	ACC
New Train Running Number received	→ IDLE	If M_ACK=1: Send "Acknowledgement" → ACC If M_ACK=0: → ACC

4.6.3.6 Note: Cancellation may be repeated, e.g. if acknowledgement was not received.

4.6.3.7 Note: More than one event may be triggered by one message, e.g. a received Pre-Announcement may result in an Acknowledgement and a Cancellation.

4.6.4 State Table for Communication Supervision

4.6.4.1 The following states are defined for communication between two peer RBCs.

Table 9 States of Communication Supervision

State	Description
NOCOMMS	No RBC/RBC communication
COMMS	RBC/RBC communication is established and supervised

4.6.4.2 The states of Handing Over RBC (4.6.2) and Accepting RBC (4.6.3) exist only within the COMMS state.

4.6.4.3 The following table specifies the incoming events.

Table 10 Incoming Events for Communication Supervision

Event	Description
Safe connection established	The safe connection to an NRBC becomes available
RBC decides to send an NRBC message	An NRBC message is to be sent. This may be a "Life Sign" message or any other NRBC message in the course of a handover transaction according to section 4.4
NRBC message received	The RBC receives an NRBC message. This may be a Life Sign or any other NRBC message in the course of a handover transaction.
Safe connection is lost	Failure of the safe connection to an NRBC is detected
No NRBC message received in due time	No NRBC message has been received within the configured time (see Configuration Items)

4.6.4.4 The following table specifies the outgoing events.

Table 11 Outgoing Events for Communication Supervision

Event	Description
Send NRBC Message	A Life Sign or other NRBC message (see 4.6.2.3 and 4.6.3.3) is sent

4.6.4.5 The following figure shows the state diagram for the Communication Supervision:

- a) The states (refer to Table 9)
- b) The incoming events (refer to Table 10)
- c) The state transitions.

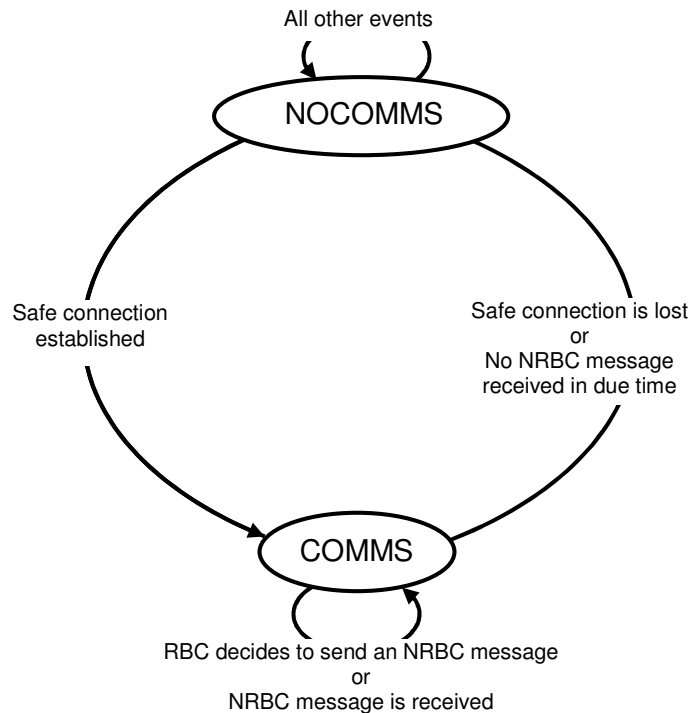

Figure 4 Communication Supervision State Diagram

4.6.4.6 For each state (see Figure 4) the following table defines for each incoming event what has to happen and which is the next state.

Table 12 Communication Supervision State Transition Table

Event	NOCOMMS	COMMS
Safe connection established	Send "Life Sign" → COMMS	
RBC decides to send an NRBC message	→ NOCOMMS	Send NRBC message → COMMS
NRBC message received	→ NOCOMMS	→ COMMS
Safe connection is lost	→ NOCOMMS	→ NOCOMMS
No NRBC message received in due time	→ NOCOMMS	→ NOCOMMS

4.7 Configuration Management

4.7.1.1 The following table lists configuration data related to the exchange of messages for the RBC-RBC interface, which should be considered for offline agreement.

Table 13 Configuration Items

Nr.	Configuration items	Description
1.	System version X.Y applicable for the interface	The applicable system version X.Y for the interface is the lowest M_VERSION operated by the neighbouring RBCs
2.	Parameters of the underlying RBC-RBC Safe Communication Interface	Details see Subset-098
3.	Identity of the adjacent RBC	NID_C, NID_RBC
4.	Identity of the border BG	For each border BG NID_C, NID_BG
5.	Location and orientation of border BG	For each border BG The format depends on the data definition used within the RBC
6.	Handling of life sign messages	Cycle times for transmission/reception. Resolution: 1 second Range: 2 – 300 seconds
7.	TSR ID assignment	To define the range of identities which may be used by the RBC
8.	LX ID assignment	To define the range of identities which may be used by the RBC

5. MESSAGES

5.1 General

- 5.1.1.1 The RBC/RBC handover ERTMS/ETCS language is based on variables, packets and messages. This chapter re-uses some of the variables and packets specified for transmission over other interfaces by [Subset-026 chapter 7].
- 5.1.1.2 New variables, which are required for NRBC messages, are specified in this document.
- 5.1.1.3 A NRBC message contains a header and an identified and coherent set of variables and packets (if needed).
- 5.1.1.4 The behaviour of the receiver shall not depend on the sequence of the optional packets given by the message.
- 5.1.1.5 The RBC shall reject a message transmitted from the NRBC if the message is not consistent.
- 5.1.1.6 An NRBC message is consistent when all checks have been completed successfully:
- Checks performed by RBC/RBC protocol have been passed (see [Subset-098])
 - Variables in the message do not have invalid values.
- 5.1.1.7 It shall be forbidden to send more instances of the same packet type in the same message, except for Packet 65 (TSR), Packet 66 (TSR Revocation) and Packet 88 (Level Crossing Information).
- 5.1.1.8 The message identifier is unique (variable NID_NRBCMESSAGE).

Table 14 List of NRBC Messages

Message identifier	Message Name	Direction
201	Pre-Announcement	RBC _{HOV} => RBC _{ACC}
202	Route Related Information request	RBC _{HOV} => RBC _{ACC}
203	Announcement	RBC _{HOV} => RBC _{ACC}
204	Cancellation	RBC _{HOV} <=> RBC _{ACC}
205	Acknowledgement	RBC _{HOV} <=> RBC _{ACC}
206	RRI Confirmation	RBC _{HOV} => RBC _{ACC}
207	Train Data	RBC _{HOV} => RBC _{ACC}
208	Train Running Number	RBC _{HOV} => RBC _{ACC}
221	Route Related Information	RBC _{ACC} => RBC _{HOV}
222	Taking Over Responsibility	RBC _{ACC} => RBC _{HOV}
223	Life Sign	RBC _{ACC} <=> RBC _{HOV}
224	Request for RRI Confirmation	RBC _{ACC} => RBC _{HOV}

- 5.1.1.9 Each message includes the message length in bytes (variable L_MESSAGE).
- 5.1.1.10 If the computed length of the message is not equal to the length given by L_MESSAGE, the entire message shall be rejected.
- 5.1.1.11 An NRBC message (except Life Sign) is identified for acknowledgement by
 - a) Identity of the sending RBC (variables NID_C and NID_RBC) **and**
 - b) Identity of the handed over engine (variable NID_ENGINE) **and**
 - c) Identity of the border BG (variables NID_C and NID_BG) **and**
 - d) Timestamp of the sending RBC (variable T_RBC).
- 5.1.1.12 Note: Non-unique identifiers for outstanding acknowledgements may have an impact on system behaviour.
- 5.1.1.13 There shall always be a time stamp increment between consecutive messages. Wrap-around of the RBC time stamp value can occur during an RBC/RBC session and shall have no impact on system behaviour.
- 5.1.1.14 Note: This time stamp does not have to be based on real time.
- 5.1.1.15 The structure of a NRBC message (except Life Sign message) is shown by Figure 5. Fields 1-9 form the header.

Field No.	VARIABLE	Remarks
1	NID_NRBCMESSAGE	Message Identifier
2	L_MESSAGE	Message length including everything (field 1 to padding)
3	NID_C	Identity of the country or region (of the sending RBC)
4	NID_RBC	Identity of the sending RBC
5	NID_ENGINE	Identity of the handed over engine
6	NID_C	Identity of the country or region (of the border balise group)
7	NID_BG	Identity of border balise group
8	T_RBC	Time stamp of sending RBC
9	M_ACK	Qualifier for acknowledgement request
10	Variables as required by NID_NRBCMESSAGE	If needed for this message. Used when sending variables, which are not included in a packet.
11	Packets as required by NID_NRBCMESSAGE	
	Padding	Bit padding to octet borders, if required.

Figure 5 Structure of NRBC Messages

5.2 Messages from the Handing Over RBC to the Accepting RBC

5.2.1 Pre-Announcement

Description	The Handing Over RBC informs the Accepting RBC that a given train is approaching its area at a specific border location.		
Content	Variable	Length	Comment
	NID_NRBCMESSAGE	8	201 (Pre-Announcement)
	L_MESSAGE	10	
	NID_C	10	
	NID_RBC	14	
	NID_ENGINE	24	
	NID_C	10	
	NID_BG	14	
	T_RBC	32	
	M_ACK	1	=1
	M_MODE	4	Only 0, 1, 2, 7, 8, 11 or 12
	Q_MASTERENGINE	1	If M_MODE = 11 (i.e. NL)
	NID_ENGINE	24	If M_MODE = 11 and Q_MASTERENGINE = 1 identity of the leading engine
	Packet 11 (Train data)		If M_MODE = 0, 1, 2, 7, 8 or 12 (i.e. FS, OS, SR, TR, PT or LS)
optional packet		Packet 5 (Train running number)	

5.2.1.1 Note: Pre-announcement is only supported for on-boards in modes FS, OS, SR, TR, PT, NL or LS because in other modes either the Accepting RBC cannot forward any information to the on-board or the on-board cannot handle an RBC/RBC handover.

5.2.2 Route Related Information Request

Description	The Handing Over RBC requests route related information from the Accepting RBC.		
Content	Variable	Length	Comment
	NID_NRBCMESSAGE	8	202 (Route related information request)
	L_MESSAGE	10	
	NID_C	10	

NID_RBC	14	
NID_ENGINE	24	
NID_C	10	
NID_BG	14	
T_RBC	32	
M_ACK	1	
D_REMAINDISTANCE	15	Remaining distance for RRI
N_REMAINEOAINTERVALS	5	Number of remaining EoA intervals
N_REMAINTSR	5	Total number of remaining TSR related packets 65 and 66
Q_ADDRESTRICTIONS	1	Flag for additional restrictions
N_REMAINLINKEDBG	5	Number of remaining linked balise groups
N_REMAINGRADIENTCHANGE	5	Number of remaining changes of gradients
N_REMAINMASECTION	5	Number of remaining MA sections
N_REMAINSPEEDCHANGE	5	Number of remaining changes of SSP
N_REMAINTRACKCONDITION	5	Number of remaining track conditions
N_REMAINASP	6	Number of remaining axle load speed profiles
N_REMAINMODEPROFILE	5	Number of remaining mode profile sections
N_REMAINLX	5	Number of remaining LX packets 88
N_REMAINPLATFORM	5	Number of remaining station platform track conditions
N_REMAINPBD	5	Number of remaining speed restrictions for permitted braking distance
Q_REMAINAXLELOAD	1	Flag, if axle load route suitability data still possible or not (only one allowed)
Q_REMAINLOADINGGAUGE	1	Flag, if loading gauge route suitability data still possible or not (only one allowed)

Q_REMAINTRACTION	1	Flag, if traction route suitability data still possible or not (only one allowed)
Q_REMAINLEVELTRANSITION	1	Flag, if level transition still possible or not
Q_REMAINTRACTIONSISTEM CHANGE	1	Flag, if traction system change still possible or not
Q_REMAINCURRENT	1	Flag, if allowed current consumption change still possible or not

5.2.2.1 Note: Parameters D_REMAINDISTANCE and N_REMAINEOAINTERVALS may be used in combination.

5.2.3 Announcement

Description	The Handing Over RBC informs the Accepting RBC that the maximum safe front end of the train has passed the location corresponding to the border		
Content	Variable	Length	Comment
	NID_NRBCMESSAGE	8	203 (Announcement)
	L_MESSAGE	10	
	NID_C	10	
	NID_RBC	14	
	NID_ENGINE	24	
	NID_C	10	
	NID_BG	14	
	T_RBC	32	
	M_ACK	1	

5.2.4 RRI Confirmation

Description	The Handing Over RBC confirms that the RRI has been processed according to the information in this RRI Confirmation message.		
Content	Variable	Length	Comment
	NID_NRBCMESSAGE	8	206 (RRI Confirmation)
	L_MESSAGE	10	
	NID_C	10	
	NID_RBC	14	
	NID_ENGINE	24	
	NID_C	10	
	NID_BG	14	

T_RBC	32	
M_ACK	1	
T_RBCCONF	32	The timestamp of the Request for RRI Confirmation message being confirmed
Q_RRICONFSTATUS	2	

5.2.5 Train Data

Description	The Handing Over RBC informs the Accepting RBC about train data received from an ETCS on-board equipment.		
Content	Variable	Length	Comment
	NID_NRBCMESSAGE	8	207 (Train Data)
	L_MESSAGE	10	
	NID_C	10	
	NID_RBC	14	
	NID_ENGINE	24	
	NID_C	10	
	NID_BG	14	
	T_RBC	32	
	M_ACK	1	=1
	Packet 11 (Train data)		

5.2.6 Train Running Number

Description	The Handing Over RBC informs the Accepting RBC about train running number of an engine being handed over.		
Content	Variable	Length	Comment
	NID_NRBCMESSAGE	8	208 (Train Running Number)
	L_MESSAGE	10	
	NID_C	10	
	NID_RBC	14	
	NID_ENGINE	24	
	NID_C	10	
	NID_BG	14	
	T_RBC	32	
	M_ACK	1	
	Packet 5 (Train running number)		

5.3 Messages from the Accepting RBC to the Handing Over RBC

5.3.1 Route Related Information

Description	Route information from the Accepting RBC to the Handing Over RBC		
Content	Variable	Length	Comment
	NID_NRBCMESSAGE	8	221 (Route Related Information)
	L_MESSAGE	10	
	NID_C	10	
	NID_RBC	14	
	NID_ENGINE	24	
	NID_C	10	
	NID_BG	14	
	T_RBC	32	
	M_ACK	1	=1 (i.e. acknowledgement is always requested)
	Q_RRIMACHANGE	2	
	Q_TDCHANGE	1	If Q_RRIMACHANGE=0
	Q_MATIMER	1	
	Packet 15		Level 2/3 Movement Authority
	Packet 21		Gradient Profile
	Packet 27		International Static Speed Profile
	optional packets		

5.3.1.1 The optional packets of NRBC message “Route related information” are

Optional packets
3, 5 (Linking), 39, 40, 41, 51, 52, 65, 66, 68, 69, 70, 71, 80, 88

5.3.1.2 Each RRI message shall provide complete information (see [Subset-026] section 3.7) for the area starting at the border balise group and shall use the border balise group as the LRBG. The RRI shall not include any information with a start or end location in the area beyond the remaining distance which was given by the last received NRBC message RRI Request.

5.3.1.3 The same rules for packets as in [Subset-026] and [Subset-040] apply.

5.3.1.4 Additional rule: packets 51, 52, 68, 69 and 70 with Q_TRACKINIT = 1 shall not be sent in the RRI message.

5.3.1.5 Note: In packets 51, 52, 68, 69 and 70 the value Q_TRACKINIT = 1 is used to reset the corresponding information. With this value, it is not possible to use such packets to send new restrictions; moreover only one instance of them is allowed in a message.

- 5.3.1.6 The total number of TSR related packets 65 and 66 in the RRI shall not exceed the limit set by N_REMAINTSR in the last received RRI Request.
- 5.3.1.7 Note: It is a configuration issue to ensure that TSR identities are not duplicated. The agreed value range for a specific RBC is applicable to both packet 65 and 66.
- 5.3.1.8 Note: It is a configuration issue to ensure that LX identities are not duplicated.
- 5.3.1.9 Note: Q_RRIMACHANGE and Q_TDCHANGE together with Q_MATIMER could help the Handing Over RBC to determine the use of the received RRI information without analysing the content of the individual packets.
- 5.3.1.10 The track description may also be changed if Q_RRIMACHANGE \neq 0.
- 5.3.1.11 The status of Q_RRIMACHANGE indicating a shortened RRI shall be maintained until an RRI message indicating the shortened status has been acknowledged by the Handing Over RBC.
- 5.3.1.12 The special/reserved value “Now” in the packets 3 (national values) and 41 (level transition order) shall not be sent in the RRI message.
- 5.3.1.13 The status of Q_TDCHANGE indicating a changed track data in the RRI shall be maintained until an RRI message indicating this changed track data has been acknowledged by the Handing Over RBC.

5.3.2 Taking Over Responsibility

Description	The Accepting RBC informs the Handing Over RBC that it has taken over the responsibility		
Content	Variable	Length	Comment
	NID_NRBCMESSAGE	8	222 (Taking Over Responsibility)
	L_MESSAGE	10	
	NID_C	10	
	NID_RBC	14	
	NID_ENGINE	24	
	NID_C	10	
	NID_BG	14	
	T_RBC	32	
	M_ACK	1	=0 (i.e. no acknowledgement is required)

5.3.3 Request for RRI Confirmation

Description	Request for confirmation including request for shortening of MA, from the Accepting RBC to the Handing Over RBC.		
Content	Variable	Length	Comment
	NID_NRBCMESSAGE	8	224 (Request for RRI Confirmation)
	L_MESSAGE	10	
	NID_C	10	
	NID_RBC	14	
	NID_ENGINE	24	
	NID_C	10	
	NID_BG	14	
	T_RBC	32	
	M_ACK	1	=1 (i.e. acknowledgement is always requested)
	Packet 15		Level 2/3 Movement Authority
	optional packet		packet 80 only

5.3.3.1 The content of packet 15 in the Request for RRI Confirmation shall not exceed the MA distance of packet 15 sent in the previous RRI.

5.4 Messages from both Accepting RBC or Handing Over RBC

5.4.1 Acknowledgement

Description	The RBC acknowledges a received message according to M_ACK. The meaning of the acknowledgement from its sender point of view is: the acknowledged message is consistent.		
Content	Variable	Length	Comment
	NID_NRBCMESSAGE	8	205 (Acknowledgement)
	L_MESSAGE	10	
	NID_C	10	
	NID_RBC	14	
	NID_ENGINE	24	
	NID_C	10	
	NID_BG	14	
T_RBC	32		

M_ACK	1	=0 (i.e. no acknowledgement is required)
T_RBCACK	32	The timestamp of the message being acknowledged

5.4.2 Cancellation

Description	When an RBC detects that the transition to or from a neighbour RBC is to be cancelled, it sends this information.		
Content	Variable	Length	Comment
	NID_NRBCMESSAGE	8	204 (Cancellation)
	L_MESSAGE	10	
	NID_C	10	
	NID_RBC	14	
	NID_ENGINE	24	
	NID_C	10	
	NID_BG	14	
	T_RBC	32	
	M_ACK	1	

5.4.3 Life Sign

Description	This message is sent if a specified time has passed since any message was sent.		
Content	Variable	Length	Comment
	NID_NRBCMESSAGE	8	223 (Life Sign)
	L_MESSAGE	10	
	NID_C	10	
	NID_RBC	14	
	T_RBC	32	

5.5 Packets

5.5.1.1 The following track-to-train packets defined in [Subset-026] are also used by NRBC messages:

Packet number	Packet Name
3	National values
5	Linking
15	Level 2/3 Movement Authority
21	Gradient Profile

Packet number	Packet Name
27	International Static Speed Profile
39	Track Condition Change of traction system
40	Track Condition Change of allowed current consumption
41	Level Transition Order
51	Axle Load Speed Profile
52	Permitted Braking Distance Information
65	Temporary Speed Restriction
66	Temporary Speed Restriction Revocation
68	Track Condition
69	Track Condition Station Platforms
70	Route Suitability Data
71	Adhesion factor
80	Mode profile
88	Level Crossing information

5.5.1.2 The following train-to-track packets defined in [Subset-026] are also used by NRBC messages:

Packet number	Packet Name
5	Train running number
11	Train data

5.6 Variables

5.6.1.1 The following variables defined in [Subset-026] are also used by NRBC messages:

Variable	Name
L_MESSAGE	Message length
M_ACK	Qualifier for acknowledgement request
M_MODE	On-board operating mode
NID_BG	Identity number of the balise group
NID_C	Identity number of the country or region
NID_ENGINE	On-board ETCS identity
NID_RBC	RBC ETCS identity number

5.6.1.2 Note: The dimensioning rules of [Subset-040] also apply.

5.6.1.3 D_REMAINDISTANCE

Name	The remaining distance beyond the border BG for which data (including the danger point and overlap of the MA) can be transmitted in NRBC message "Route Related Information".		
Description	The RRI must not include any information outside the remaining distance.		
Length of variable	Minimum Value	Maximum Value	Resolution/formula
15 bits	0	32766	1m
Special/Reserved Values	32767	No restriction given	

5.6.1.4 N_REMAINASP

Name	The remaining number of axle load speed profile changes for a NRBC message "Route Related Information"		
Description			
Length of variable	Minimum Value	Maximum Value	Resolution/formula
6 bits	0	15	Integers

5.6.1.5 N_REMAINEOAINTERVALS

Name	The remaining number of EoA intervals for a NRBC message "Route Related Information"		
Description			
Length of variable	Minimum Value	Maximum Value	Resolution/formula
5 bits	0	30	Integers
Special/Reserved Values	31	No restriction given	

5.6.1.6 N_REMAINGRADIENTCHANGES

Name	The remaining number of gradient profile changes for a NRBC message "Route Related Information"		
Description			
Length of variable	Minimum Value	Maximum Value	Resolution/formula
5 bits	0	31	Integers

5.6.1.7 N_REMAINLINKEDBG

Name	The remaining number of linked balise groups for a NRBC message "Route Related Information"		
Description			
Length of variable	Minimum Value	Maximum Value	Resolution/formula
5 bits	0	29	Integers

5.6.1.8 N_REMAINLX

Name	The remaining number of Level Crossing Information packets for a NRBC message "Route Related Information"		
Description			
Length of variable	Minimum Value	Maximum Value	Resolution/formula
5 bits	0	10	Integers

5.6.1.9 N_REMAINMASECTION

Name	The remaining number of MA sections for a NRBC message "Route Related Information"		
Description	The end section is included in this number.		
Length of variable	Minimum Value	Maximum Value	Resolution/formula
5 bits	0	6	Integers

5.6.1.10 N_REMAINMODEPROFILE

Name	The remaining number of mode profile changes for a NRBC message "Route Related Information"		
Description	This is the first element plus up to 2 iterations.		
Length of variable	Minimum Value	Maximum Value	Resolution/formula
5 bits	0	3	Integers

5.6.1.11 N_REMAINPBD

Name	The remaining number of speed restrictions for permitted braking distance for a NRBC message "Route Related Information"		
Description	This is the first element plus up to 2 iterations.		
Length of variable	Minimum Value	Maximum Value	Resolution/formula
5 bits	0	3	Integers

5.6.1.12 N_REMAINPLATFORM

Name	The remaining number of station platform track conditions for a NRBC message "Route Related Information"		
Description			
Length of variable	Minimum Value	Maximum Value	Resolution/formula
5 bits	0	5	Integers

5.6.1.13 N_REMAINSPEEDCHANGE

Name	The remaining number of static speed profile changes for a NRBC message "Route Related Information"		
Description			
Length of variable	Minimum Value	Maximum Value	Resolution/formula
5 bits	0	31	Integers

5.6.1.14 N_REMAINTRACKCOND

Name	The remaining number of track condition for a NRBC message "Route Related Information"		
Description	This is the first element plus up to 19 iterations.		
Length of variable	Minimum Value	Maximum Value	Resolution/formula
5 bits	0	20	Integers

5.6.1.15 N_REMAINTSR

Name	The remaining total number of temporary speed restriction and revocation packets for a NRBC message "Route Related Information"		
Description			
Length of variable	Minimum Value	Maximum Value	Resolution/formula
5 bits	0	10	Integers

5.6.1.16 NID_NRBCMESSAGE

Name	Message identifier		
Description	Identifier of a NRBC message		
Length of variable	Minimum Value	Maximum Value	Resolution/formula
8 bits	0	255	Numbers
Special/Reserved Values	201	Pre-Announcement	
	202	Route Related Information Request	
	203	Announcement	
	204	Cancellation	
	205	Acknowledgement	
	206	RRI Confirmation	
	207	Train Data	
	208	Train Running Number	
	221	Route Related Information	
	222	Taking Over Responsibility	
	223	Life Sign	
	224	Request for RRI Confirmation	

5.6.1.17 Q_ADDRESTRICTIONS

Name	Flag additional restrictions		
Description			
Length of variable	Minimum Value	Maximum Value	Resolution/formula
1 bit			
Special/Reserved Values	0	No further restrictions following	
	1	Further restrictions following	

5.6.1.18 Q_MASTERENGINE

Name	Flag indication if the NID of the master engine is known		
Description			
Length of variable	Minimum Value	Maximum Value	Resolution/formula
1 bit			
Special/Reserved Values	0	No	
	1	Yes	

5.6.1.19 Q_MATIMER

Name	Flag indication if MA contains timers		
Description			
Length of variable	Minimum Value	Maximum Value	Resolution/formula
1 bit			
Special/Reserved Values	0	No	
	1	Yes	

5.6.1.20 Q_REMAINAXLELOAD

Name	Flag, if one route suitability data for axle load is possible or not		
Description			
Length of variable	Minimum Value	Maximum Value	Resolution/formula
1 bit			
Special/Reserved Values	0	No	
	1	Yes	

5.6.1.21 Q_REMAINCURRENT

Name	Flag, if change in allowed current consumption is possible or not		
Description			
Length of variable	Minimum Value	Maximum Value	Resolution/formula
1 bit			
Special/Reserved Values	0	No	
	1	Yes	

5.6.1.22 Q_REMAINLEVELTRANSITION

Name	Flag, if level transition still possible or not		
Description			
Length of variable	Minimum Value	Maximum Value	Resolution/formula
1 bit			
Special/Reserved Values	0	No	
	1	Yes	

5.6.1.23 Q_REMAINLOADINGGAUGE

Name	Flag, if one route suitability data for loading gauge is possible or not		
Description			
Length of variable	Minimum Value	Maximum Value	Resolution/formula
1 bit			
Special/Reserved Values	0	No	
	1	Yes	

5.6.1.24 Q_REMAINTRACTION

Name	Flag, if one route suitability data for traction is possible or not		
Description			
Length of variable	Minimum Value	Maximum Value	Resolution/formula
1 bit			
Special/Reserved Values	0	No	
	1	Yes	

5.6.1.25 Q_REMAINTRACTIONSYSTEMCHANGE

Name	Flag, if traction system change still possible or not		
Description			
Length of variable	Minimum Value	Maximum Value	Resolution/formula
1 bit			
Special/Reserved Values	0	No	
	1	Yes	

5.6.1.26 Q_RRCONFSTATUS

Name	Status of RRI Confirmation		
Description	Indication whether the confirmation is negative or positive		
Length of variable	Minimum Value	Maximum Value	Resolution/formula
2 bit			
Special/Reserved Values	0	No response from train, no further confirmation will be sent from RBC _{HOV}	
	1	Not confirmed (negative)	
	2	Confirmed (positive)	
	3	Spare	

5.6.1.27 Q_RRIMACHANGE

Name	Type of MA change		
Description	Relation of MA in the current RRI message to the MA in the last sent RRI message, if any.		
Length of variable	Minimum Value	Maximum Value	Resolution/formula
2 bits			
Special/Reserved Values	0	Unchanged	
	1	Created	
	2	Extended	
	3	Shortened	

5.6.1.28 Q_TDCHANGE

Name	Change of track data		
Description	Indication whether the track data has changed in respect to the last sent RRI message, if any. Track data applies to any packets in the RRI message except packet 15.		
Length of variable	Minimum Value	Maximum Value	Resolution/formula
1 bit			
Special/Reserved Values	0	Not changed	
	1	Changed	

5.6.1.29 T_RBC

Name	Time stamp of sending RBC		
Description	Time stamp. It is used as unique identification for any message. The unit is count of 10ms, i.e. 4294967295 corresponds to 42949672.95s		
Length of variable	Minimum Value	Maximum Value	Resolution/formula
32 bits	0	4294967295	10 ms

5.6.1.30 T_RBCACK

Name	The timestamp of the message being acknowledged.		
Description	The timestamp of the received message is used (together with Identification fields of the header) as unique identification of the message being acknowledged.		
Length of variable	Minimum Value	Maximum Value	Resolution/formula
32 bits	0	4294967295	10 ms

5.6.1.31 T_RBCCONF

Name	The timestamp of the message being confirmed.		
Description	The timestamp of the received message is used (together with Identification fields of the header) as unique identification of the message being confirmed.		
Length of variable	Minimum Value	Maximum Value	Resolution/formula
32 bits	0	4294967295	10 ms

6. MANAGEMENT OF OLDER SYSTEM VERSIONS

6.1 Scope

6.1.1.1 An RBC operating with a given ERTMS/ETCS system version shall support any of the RBC/RBC languages defined in this document corresponding to the ERTMS/ETCS system versions included in the envelope of legally operated system versions (see Subset-026 clause 6.4), which are equal to or lower than its own ERTMS/ETCS system version..

6.1.1.2 If two RBCs have different system versions X, the RBC operating with X=2 is responsible to translate the information exchanged over the interface:

- When forwarding it to an X=1 RBC, it must be translated from X=2 into X=1
- When receiving it from an X=1 RBC, it must be translated from X=1 into X=2

6.1.1.3 For exchange of information between two RBCs of different system version X, the following types of translation are referred to in the subsequent sections:

T1: information received by RBC_{ACC} X=2 from RBC_{HOV} X=1

T2: information sent by RBC_{ACC} X=2 to RBC_{HOV} X=1

T3: information sent by RBC_{HOV} X=2 to RBC_{ACC} X=1

T4: information received by RBC_{HOV} X=2 from RBC_{ACC} X=1

6.1.1.4 Figure 6 shows the possible combinations of system versions of communicating RBCs and where the different translations T1 to T4 are appropriate.

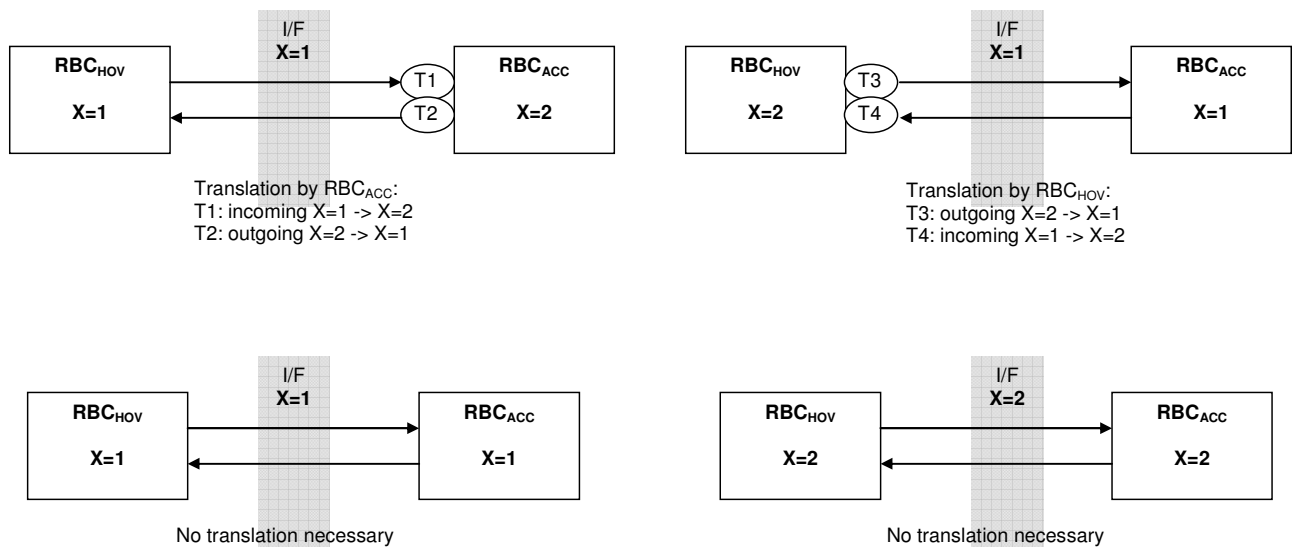

Figure 6: Interfacing RBCs with different system versions X

6.1.1.5 For each possible RBC-RBC interface the following table identifies the applicable sections of Chapter 6 according to the operated system version of the RBC and the system version of the interface.

Table 15 - Applicable Sections of Chapter 6 (marked with X)

System Version of RBC	System Version of the Interface	Applicable Sections of Chapter 6				
		6.2	6.3	6.4	6.5	6.6
2.0	2.0					
	1.1	X	X	X	X	X
	1.0	X	X	X	X	
1.1	1.1	X	X	X		X
	1.0	X	X	X		
1.0	1.0	X	X	X		

6.2 General Requirements

6.2.1.1 An RBC operating with system version X=1 or an RBC X=2 which is exchanging information with an RBC X=1 shall comply with the requirements from chapter 4 and 5 of this document with the following exceptions.

6.3 Exceptions to Chapter 4

6.3.1.1 In clause 4.2.1.1 section A.5 of Annex A shall be replaced by section B.3 of Annex B.

6.3.1.2 Clause 4.4.1.1 shall be replaced with: “The Handing Over RBC shall supervise the RBC/RBC communication from the reception of the first RRI NRBC message until reception of Taking Over Responsibility NRBC message or until the transaction has been cancelled.”

6.3.1.3 Clause 4.4.1.2 shall be replaced with: “If the safe connection between the RBCs is lost (e.g. by an error in the lower layers):

- a) On-going handover transaction shall not be aborted.
- b) Re-establishment of the safe connection shall be requested by the RBC responsible for this task (see Table 13, list item 2)
- c) If the re-establishment of the safe connection fails, the RBC/RBC handover transaction shall be aborted by the RBCs.

6.3.1.3.1 Note: The conditions for determining that the re-establishment has failed are implementation matter for both RBCs.”

6.3.1.4 Clause 4.4.1.3 shall not apply.

- 6.3.1.5 Clause 4.4.1.5 shall not apply.
- 6.3.1.6 Clause 4.4.1.6 shall be replaced with: “The Accepting RBC shall send an appropriate NRBC message when a handover transaction is ongoing and a specified time has passed since any NRBC message was sent.”
- 6.3.1.7 Clauses 4.4.1.7 and 4.4.1.7.1 shall not apply.
- 6.3.1.8 Clause 4.5.1.7 shall not apply.
- 6.3.1.9 Section 4.6.2 shall be replaced with section B.1 from Annex B.
- 6.3.1.10 Section 4.6.3 shall be replaced with section B.2 from Annex B.
- 6.3.1.11 Section 4.6.4 shall not apply.
- 6.3.1.12 In Table 13, configuration item 8 [LX ID assignment] shall not apply.

6.4 Exceptions to Chapter 5

- 6.4.1.1 Added clause 5.1.1.1.1 shall apply: “All relevant exceptions for packet structures and variable definitions specified in [Subset-026 section 6.5.1.5] shall apply as well as the exception for the structure of packet 11 specified in [Subset-026 section 6.6.3.4].”
- 6.4.1.2 Clause 5.1.1.7 shall be replaced with: “It shall be forbidden to send more instances of the same packet type in the same message, except for Packet 65 (TSR) and Packet 66 (TSR Revocation).”
- 6.4.1.3 In Table 14, message with identifier 208 shall not apply.
- 6.4.1.4 In Table 14, message with identifier 223 shall only be valid for direction RBC_{ACC} to RBC_{HOV}.
- 6.4.1.5 In clause 5.1.1.11, the exception “except for Life Sign” shall not apply.
- 6.4.1.6 In clause 5.1.1.15, the exception “except Life Sign message” shall not apply.
- 6.4.1.7 In clause 5.2.1, the Pre-Announcement message shall be replaced with:

Pre-Announcement

Description	The Handing Over RBC informs the Accepting RBC that a given train is approaching its area at a specific border location.		
Content	Variable	Length	Comment
	NID_NRBCMESSAGE	8	201 (Pre-Announcement)
	L_MESSAGE	10	
	NID_C	10	
	NID_RBC	14	
	NID_ENGINE	24	
	NID_C	10	
	NID_BG	14	

T_RBC	32	
M_ACK	1	=1
M_MODE	4	Only 0, 1, 2, 7, 8, 11 or 12
Q_MASTERENGINE	1	If M_MODE = 11 (i.e. NL)
NID_ENGINE	24	If M_MODE = 11 and Q_MASTERENGINE = 1 identity of the leading engine
Packet 11 (Train data)		If M_MODE = 0, 1, 2, 7, 8 or 12 (i.e. FS, OS, SR, TR, PT or LS)

6.4.1.8 In clause 5.2.2, the Route Related Information Request message shall be replaced with:

Route Related Information Request

Description	The Handing Over RBC requests route related information from the Accepting RBC.		
Content	Variable	Length	Comment
	NID_NRBCMESSAGE	8	202 (Route related information request)
	L_MESSAGE	10	
	NID_C	10	
	NID_RBC	14	
	NID_ENGINE	24	
	NID_C	10	
	NID_BG	14	
	T_RBC	32	
	M_ACK	1	
	D_REMAINDISTANCE	15	Remaining distance for RRI
	N_REMAINEOAINTERVALS	5	Number of remaining EoA intervals
	N_REMAINTSR	5	Total number of remaining TSR related packets 65 and 66
	Q_ADDRESTRICTIONS	1	Flag for additional restrictions
	N_REMAINLINKEDBG	5	Number of remaining linked balise groups
	N_REMAINGRADIENTCHANGE	5	Number of remaining changes of gradients

N_REMAINMASECTION	5	Number of remaining MA sections
N_REMAINSPEEDCHANGE	5	Number of remaining changes of SSP
N_REMAINTRACKCONDITION	5	Number of remaining track conditions
N_REMAINASP	6	Number of remaining axle load speed profiles
N_REMAINMODEPROFILE	5	Number of remaining mode profile sections
Q_REMAINAXLELOAD	1	Flag, if axle load route suitability data still possible or not (only one allowed)
Q_REMAINLOADINGGAUGE	1	Flag, if loading gauge route suitability data still possible or not (only one allowed)
Q_REMAINTRACTION	1	Flag, if traction route suitability data still possible or not (only one allowed)
Q_REMAINLEVELTRANSITION	1	Flag, if level transition still possible or not
Q_REMAINTRACTIONSISTEM CHANGE	1	Flag, if traction system change still possible or not

6.4.1.9 Clause 5.2.6 shall not apply.

6.4.1.10 In clause 5.3.1.1, the list of optional packets shall be replaced with:

Optional packets
3, 5 (Linking), 39, 41, 51, 65, 66, 68, 70, 71, 80

6.4.1.11 Clause 5.3.1.4 shall be replaced with: “Additional rule: packets 51, 68 and 70 with Q_TRACKINIT = 1 shall not be sent in the RRI message.”

6.4.1.12 Clause 5.3.1.5 shall be replaced with: “Note: In packets 51, 68 and 70 the value Q_TRACKINIT = 1 is used to reset the corresponding information. With this value, it is not possible to use such packets to send new restrictions; moreover only one instance of them is allowed in a message.”

6.4.1.13 Clause 5.3.1.8 shall not apply.

6.4.1.14 Added section 5.3.4 for the Life Sign message shall apply:

Life Sign

Description	The Accepting RBC sends a Life Sign message, if a HOV transaction is ongoing and a specified time has passed since any message was sent.		
Content	Variable	Length	Comment
	NID_NRBCMESSAGE	8	223 (Life Sign)
	L_MESSAGE	10	
	NID_C	10	
	NID_RBC	14	
	NID_ENGINE	24	
	NID_C	10	
	NID_BG	14	
	T_RBC	32	
	M_ACK	1	=0 (i.e. no acknowledgement is required)

6.4.1.15 Section 5.4.3 shall not apply.

6.4.1.16 In clause 5.5.1.1, the list of track-to-train packets shall be replaced with:

Packet number	Packet Name
3	National values
5	Linking
15	Level 2/3 Movement Authority
21	Gradient Profile
27	International Static Speed Profile
39	Track Condition Change of traction system
41	Level Transition Order
51	Axle Load Speed Profile
65	Temporary Speed Restriction
66	Temporary Speed Restriction Revocation
68	Track Condition
70	Route Suitability Data
71	Adhesion factor
80	Mode profile

6.4.1.17 In clause 5.5.1.2, the list of train-to-track packets shall be replaced with:

Packet number	Packet Name
11	Train data

6.4.1.18 Clause 5.6.1.8 shall not apply.

6.4.1.19 Clause 5.6.1.11 and 5.6.1.12 shall not apply.

6.4.1.20 The table in clause 5.6.1.16 shall be replaced with:

Name	Message identifier		
Description	Identifier of a NRBC message		
Length of variable	Minimum Value	Maximum Value	Resolution/formula
8 bits	0	255	Numbers
Special/Reserved Values	201	Pre-Announcement	
	202	Route related information request	
	203	Announcement	
	204	Cancellation	
	205	Acknowledgement	
	206	RRI Confirmation	
	207	Train Data	
	221	Route related information	
	222	Taking Over Responsibility	
	223	Life Sign	
	224	Request for RRI Confirmation	

6.4.1.21 Clause 5.6.1.21 shall not apply.

6.5 Additional Requirements for an RBC X=2 Communicating with an RBC X=1

6.5.1 General

6.5.1.1 The requirements in this section shall apply if the lowest system version operated by the two neighbouring RBCs has the value X=1 (see configuration item 1 of Table 13).

6.5.1.2 In Table 13 additional configuration item shall apply:

Configuration items	Description
National values for braking curves for the neighbouring RBC	Default values or set of national values for braking curves of the neighbouring RBC X=1 in case packet 3 is received without packet 203.

6.5.1.3 If an RRI sent to an RBC X=1 contains packet 41 then packet 41 shall include all applicable values of NID_STM containing the national system(s) installed in the infrastructure, see [Subset-035 clause 10.2.1.2.a].

6.5.1.4 In case RRI, which is sent to an RBC X=1, contains packet 70 then Q_SUITABILITY shall not be set to value "00" or "01".

- 6.5.1.5 If RRI received from an RBC X=1 contains both packets 39 and 239, then packet 39 shall be ignored.
- 6.5.1.6 In case RRI received from an RBC X=1 contains packet 51 with Q_TRACKINIT = 1, then packet 51 shall be ignored.
- 6.5.1.7 If an RRI received from an RBC X=1 contains both packet 68 and 206 then packet 68 shall be ignored.
- 6.5.1.8 If an RRI received from an RBC X=1 contains both packet 70 and 207 then packet 70 shall be ignored;
- 6.5.1.9 The rules for translation types T1, T2, T3 and T4 given in sections 6.5.2, 6.5.3, 6.5.4 and 6.5.5 shall apply.
- 6.5.1.9.1 Note: Translation rules are given where these can be harmonised. Where translation rules are not given the specific translation rules are outside the scope of this document.

6.5.2 T1: Information Received by RBC_{ACC} X=2 from RBC_{HOV} X=1

- 6.5.2.1 If a packet 11 is received from an RBC X=1 in a Pre-Announcement message or a Train Data message then the value of NC_TRAIN shall be interpreted according to the table

Value received from X=1 RBC	Value used by RBC X=2
NC_TRAIN	NC_CDTRAIN
xxx xxxx xxxx xx1x	0
xxx xxxx xxxx x1xx	1
xxx xxxx xxxx 1xxx	2
xxx xxxx xxx1 xxxx	3
xxx xxxx xx1x xxxx	4
xxx xxxx x1xx xxxx	5
x1x xxxx xxxx xxxx	6
xxx xxxx 1xxx xxxx	7
xx1 xxxx xxxx xxxx	8
xxx xxxx xxxx xxx1	9
xxx xxx1 xxxx xxxx	10
	NC_TRAIN
xxx xx1x xxxx xxxx	xxx xxxx xxxx xxx1
xxx x1xx xxxx xxxx	xxx xxxx xxxx xx1x
xxx 1xxx xxxx xxxx	xxx xxxx xxxx x1xx

6.5.2.2 Note: a packet 11 received from an RBC X=1 will always contain a value of M_LOADINGGAUGE of 0, as this is the only value reported by the B3 on-board.

6.5.2.3 If a packet 11 is received from an RBC X=1 in a Pre-Announcement message or a Train Data message then the value of M_AXLELOAD shall be interpreted according to the table

Value received from X=1 RBC	Value used by RBC X=2
16 t	A
17 t	HS17
18 t	B2
20 t	C4
22,5 t	D4xL
25 t	E5

6.5.2.4 Note: a packet 11 received from an RBC X=1 will always contain a value of the first N_ITER of 0, as this is the only value reported by the B3 on-board.

6.5.2.5 Note: Values of other variables in packet 11 received from an RBC X=1 are interpreted as received.

6.5.2.6 Note: In case an engine is pre-announced by an RBC X=1 the packet 5 will not be received in the Pre-Announcement message.

6.5.3 T2: Information Sent by RBC_{ACC} X=2 to RBC_{HOV} X=1

6.5.3.1 If an RRI to be sent to an RBC X=1 contains a packet 27 and the combination of values of Q_DIFF, NC_CDDIFF, and NC_DIFF is contained in the following table then the value of NC_DIFF sent in the RRI shall be set according to the table

Value in X=2 RBC			Value sent to X=1 RBC
Q_DIFF(n)	NC_CDDIFF(n)	NC_DIFF	NC_DIFF
0	0 (80 mm)	N/A	1 (80 mm)
0	1 (100 mm)	N/A	2 (100 mm)
0	2 (130 mm)	N/A	3 (130 mm)
0	3 (150 mm)	N/A	4 (150 mm)
0	4 (165 mm)	N/A	5 (165 mm)
0	5 (180 mm)	N/A	6 (180 mm)
0	6 (210 mm)	N/A	13 (210 mm)
0	7 (225 mm)	N/A	7 (225 mm)
0	8 (245 mm)	N/A	12 (245 mm)
0	9 (275 mm)	N/A	0 (275 mm)
0	10 (300 mm)	N/A	8 (300 mm)

Value in X=2 RBC			Value sent to X=1 RBC
Q_DIFF(n)	NC_CDDIFF(n)	NC_DIFF	NC_DIFF
1	N/A	0	9
1	N/A	1	10
1	N/A	2	11

6.5.3.1.1 In addition [Subset-026 clause 6.5.1.2.9] shall apply.

6.5.3.2 If an RRI to be sent to an RBC X=1 contains a packet 39 and the combination of values of M_VOLTAGE and NID_CTRACTION is contained in the following table then the value of M_TRACTION shall be set according to the table.

Value in X=2 RBC		Value sent to X=1 RBC
M_VOLTAGE	NID_CTRACTION	M_TRACTION
0	-	0
3	10	1
1	12	2
1	13	3
4	14	5
4	1	6
1	2	7
1	3	8
2	19	11
2	20	12
2	21	13
2	22	15
1	11	26
1	18	31
3	15	32
3	16	33
1	17	34
2	4	41
2	5	42
2	6	43
2	7	44
2	8	45
2	9	46

6.5.3.3 In case RRI, which is sent to an RBC X=1, contains packet 51 variable M_AXLELOAD shall be set according to the following table:

Value in X=2 RBC (M_AXLELOADCAT)	Value sent to X=1 RBC (M_AXLELOAD)
A	16 t
HS17	17 t
B1	18 t
B2	18 t
C2	20 t
C3	20 t
C4	20 t
D2	22,5 t
D3	22,5 t
D4	22,5 t
D4xL	22,5 t
E4	25 t
E5	25 t

6.5.3.4 If an RRI to be sent to an RBC X=1 contains a packet 70 and the variable Q_SUITABILITY is set to value “10” and the combination of values of M_VOLTAGE and NID_CTRACTION is contained in the following table then the value of M_TRACTION shall be set according to the table.

Value in X=2 RBC		Value sent to X=1 RBC
M_VOLTAGE	NID_CTRACTION	M_TRACTION
0	-	0
3	10	1
1	12	2
1	13	3
4	14	5
4	1	6
1	2	7
1	3	8
2	19	11
2	20	12
2	21	13
2	22	15
1	11	26
1	18	31

Value in X=2 RBC		Value sent to X=1 RBC
M_VOLTAGE	NID_CTRACTION	M_TRACTION
3	15	32
3	16	33
1	17	34
2	4	41
2	5	42
2	6	43
2	7	44
2	8	45
2	9	46

6.5.4 T3: Information Sent by RBC_{HOV} X=2 to RBC_{ACC} X=1

6.5.4.1 In case an engine has to be pre-announced or a new Train Data message has to be sent to an RBC X=1 then packet 11 shall be translated as follows:

Description	Validated train data.		
Transmitted to	RBC		
Content	Variable	Length	Comment
	NID_PACKET	8	
	L_PACKET	13	
	NID_OPERATIONAL	32	See translation [a]
	NC_TRAIN	15	See translation [b]
	L_TRAIN	12	
	V_MAXTRAIN	7	
	M_LOADINGGAUGE	8	See translation [c]
	M_AXLELOAD	7	See translation [d]
	M_AIRTIGHT	2	
	N_ITER	5	See translation [e]
	N_ITER	5	
	NID_NTC (k)	8	Type of National System available

[a] NID_OPERATIONAL shall be set to the value valid for that train.

[b] NC_TRAIN shall be set according to the following table:

Value received from on-board	Value sent to X=1 RBC
NC_CDTRAIN	NC_TRAIN
0	xxx xxxx xxxx xx1x
1	xxx xxxx xxxx x1xx

2	xxx xxxx xxxx 1xxx
3	xxx xxxx xxx1 xxxx
4	xxx xxxx xx1x xxxx
5	xxx xxxx x1xx xxxx
6	x1x xxxx xxxx xxxx
7	xxx xxxx 1xxx xxxx
8	xx1 xxxx xxxx xxxx
9	xxx xxxx xxxx xxx1
10	xxx xxx1 xxxx xxxx
NC_TRAIN	
000 0000 0000 0000	No bit is set to 1
xxx xxxx xxxx xxx1	xxx xx1x xxxx xxxx
xxx xxxx xxxx xx1x	xxx x1xx xxxx xxxx
xxx xxxx xxxx x1xx	xxx 1xxx xxxx xxxx
Other values	No bit is set to 1

[c] M_LOADINGGAUGE shall be set to 0.

[d] M_AXLELOAD shall be set according to the following table:

Value received from on-board (M_AXLELOADCAT)	Value sent to X=1 RBC (M_AXLELOAD)
A	16 t
HS17	17 t
B1	18 t
B2	18 t
C2	20 t
C3	20 t
C4	20 t
D2	22,5 t
D3	22,5 t
D4	22,5 t
D4xL	22,5 t
E4	25 t
E5	25 t

[e] N_ITER shall be set to 0.

6.5.4.2 Note In case an engine is pre-announced or a new Train Data message is sent to an RBC X=1 the train running number cannot be sent in packet 5 but only as part of the train data in packet 11.

6.5.5 T4: Information Received by RBC_{HOV} X=2 from RBC_{ACC} X=1

6.5.5.1 In case RRI received from an RBC_{ACC} X=1 contains packet 3 the values Q_NVLOCACC and V_NVLIMSUPERV shall be set to default values when forwarding the information to the on-board.

6.5.5.2 In case RRI received from an RBC_{ACC} X=1 contains packet 3 but not packet 203, the braking curve parameters contained in a packet 203 shall be set to pre-configured values (see 6.5.1.2) when forwarding the information to the on-board.

6.5.5.3 In case RRI, which is received from an RBC_{ACC} X=1 contains packet 27 and if N_ITER (following Q_FRONT) \neq 0, the variables Q_DIFF, NC_CDDIFF and NC_DIFF (as specified for system version number X=2) shall be set according to the following table when forwarding the information from packet 27 to the on-board:

Value received from X=1 RBC	Translated values transmitted to on-board		
NC_DIFF	Q_DIFF	NC_CDDIFF	NC_DIFF
0	0	9	-
1	0	0	-
2	0	1	-
3	0	2	-
4	0	3	-
5	0	4	-
6	0	5	-
7	0	7	-
8	0	10	-
9	1	-	0
10	1	-	1
11	1	-	2
12	0	8	-
13	0	6	-

6.5.5.4 In case RRI which is received from an RBC X=1 contains a packet 39 without a packet 239 and M_TRACTION is equal to one of the values in the following table then the variables M_VOLTAGE and NID_CTRACTION shall be set according to the table when forwarding the information from packet 39 to the on-board:

Value received from X=1 RBC	Translated values transmitted to on-board	
M_TRACTION	M_VOLTAGE	NID_CTRACTION
0	0	-
1	3	10
2	1	12

Value received from X=1 RBC	Translated values transmitted to on-board	
	M_VOLTAGE	NID_CTRACTION
3	1	13
5	4	14
6	4	1
7	1	2
8	1	3
11	2	19
12	2	20
13	2	21
15	2	22
26	1	11
31	1	18
32	3	15
33	3	16
34	1	17
41	2	4
42	2	5
43	2	6
44	2	7
45	2	8
46	2	9

6.5.5.5 In case RRI which is received from an RBC X=1 contains a packet 39 without a packet 239 and if M_TRACTION is not equal to one of the values that are listed in the table above, then packet 39 shall be ignored.

6.5.5.6 Note: Regarding packet 41 it is assumed that the table of priorities for the X=1 area can be forwarded to an on-board without a need for translation.

6.5.5.7 In case RRI, which is received from an RBC_{ACC} X=1 contains packet 51, variable M_AXLELOADCAT (introduced in system version X=2) shall be set according to the following table when forwarding the information from packet 51 to the on-board:

Value received from X=1 RBC	Translated value transmitted to on-board
M_AXLELOAD	M_AXLELOADCAT
$M_AXLELOAD \leq 16 \text{ t}$	A
$16 \text{ t} < M_AXLELOAD \leq 17 \text{ t}$	HS17
$17 \text{ t} < M_AXLELOAD \leq 18 \text{ t}$	B1
$18 \text{ t} < M_AXLELOAD \leq 20 \text{ t}$	C2

Value received from X=1 RBC	Translated value transmitted to on-board
M_AXLELOAD	M_AXLELOADCAT
$20 \text{ t} < M_AXLELOAD \leq 22.5 \text{ t}$	D2
$22.5 \text{ t} < M_AXLELOAD \leq 40 \text{ t}$ or M_AXLELOAD = "Axle load above 40 t"	E4

6.5.5.8 In case RRI received from an RBC X=1 contains packet 68 without a packet 206 and if M_TRACKCOND = 1 or 2, then M_TRACKCOND (as specified for system version number X=2) shall be set to 0 when forwarding the information from packet 68 to the on-board.

6.5.5.9 In case RRI received from an RBC X=1 contains packet 70 without a packet 207 and if the value "10" of the variable Q_SUITABILITY is used with M_TRACTION equal to one of the values that are listed in the table below, the variables M_VOLTAGE and NID_CTRACTION (introduced in system version X.Y = 1.1) shall be set according to the table when forwarding the information from packet 70 to the on-board. Any other route suitability information not related to the traction system shall not be forwarded to the on-board.

Value received from X=1 RBC	Translated values transmitted to on-board	
	M_TRACTION	NID_CTRACTION
0	0	-
1	3	10
2	1	12
3	1	13
5	4	14
6	4	1
7	1	2
8	1	3
11	2	19
12	2	20
13	2	21
15	2	22
26	1	11
31	1	18
32	3	15
33	3	16
34	1	17
41	2	4
42	2	5

Value received from X=1 RBC	Translated values transmitted to on-board	
M_TRACTION	M_VOLTAGE	NID_CTRACTION
43	2	6
44	2	7
45	2	8
46	2	9

- 6.5.5.9.1 Note: If the packet 70 contains more than one element then the distance information might have to be adjusted accordingly due to elements that are not forwarded to the on-board.
- 6.5.5.10 In case RRI or Request for RRI Confirmation received from an RBC X=1 contains packet 80, then variable Q_MAMODE (introduced in system version number X=2) shall be set to 1 when forwarding the information from packet 80 to the on-board.
- 6.5.5.11 In case RRI received from an RBC_{ACC} X=1 contains packet 203, the National Values included in the packet 203 shall be appended to the packet 3 received in the same message, in order to form a single set of National Values, when forwarding the information from packet 203 to the on-board.
- 6.5.5.12 In case RRI received from an RBC X=1 contains packet 206 the variable NID_PACKET shall be set to 68 when forwarding the information from packet 206 to the on-board.
- 6.5.5.13 In case RRI received from an RBC X=1 contains packet 207 the variable NID_PACKET shall be set to 70 when forwarding the information from packet 207 to the on-board.
- 6.5.5.14 In case RRI received from an RBC X=1 contains packet 239 the variable NID_PACKET shall be set to 39 when forwarding the information from packet 239 to the on-board.

6.6 Additional Requirements when System Version 1.1 is Applicable for the Interface

- 6.6.1.1 The requirements in this section shall apply if the lowest system version operated by the two neighbouring RBCs has the value "1.1" (see configuration item 1 of Table 13).
- 6.6.1.2 Note: In clause 6.4.1.8 there are no specific flags for the contents of packet 206, 207 and 239. Therefore the RBC_{HOV} must assume that it may get two packets, i.e. 68/206, 70/207 and 39/239 in the RRI, and set the restrictions in the RRI Request so that they reflect the most restrictive value applicable to either of the two packets.
- 6.6.1.3 In addition to clause 5.3.1.1 the optional packets of NRBC message "Route related information" shall also include 203, 206, 207 and 239.
- 6.6.1.4 Packet 203 shall not be sent in NRBC message "Route related information" without also sending packet 3.
- 6.6.1.5 In addition to clause 5.3.1.4 packets 206 and 207 with Q_TRACKINIT = 1 shall not be sent in the RRI message.



6.6.1.6 In addition to clause 5.5.1.1 the following packets defined in [Subset-026] are also used by NRBC messages:

Packet number	Packet Name
203	National values for braking curves
206	Track Condition
207	Route Suitability Data
239	Track Condition Change of traction system

Annex A – (informative) RBC/RBC Communication

A.1 The RBC/RBC Communication Model

- A.1.1.1 An application entity responsible for RBC/RBC handover (RBC/RBC communication entity) communicates with its peer entity by means of the RBC/RBC handover protocol.
- A.1.1.2 The exchange of application messages (NRBC messages) is a logical view only. For real data exchange the services of the RBC-RBC Safe Communication Interface [Subset-098] will be used. Access to these services is possible by means of the service primitives at service access points (SAP). These service primitives are dependent on the implementation and outside the scope of this document.
- A.1.1.3 The RBC/RBC handover protocol is independent of the RBC safe communication protocol.
- A.1.1.4 Figure A1 shows a model of the RBC/RBC communication. This model does not restrict any implementations.

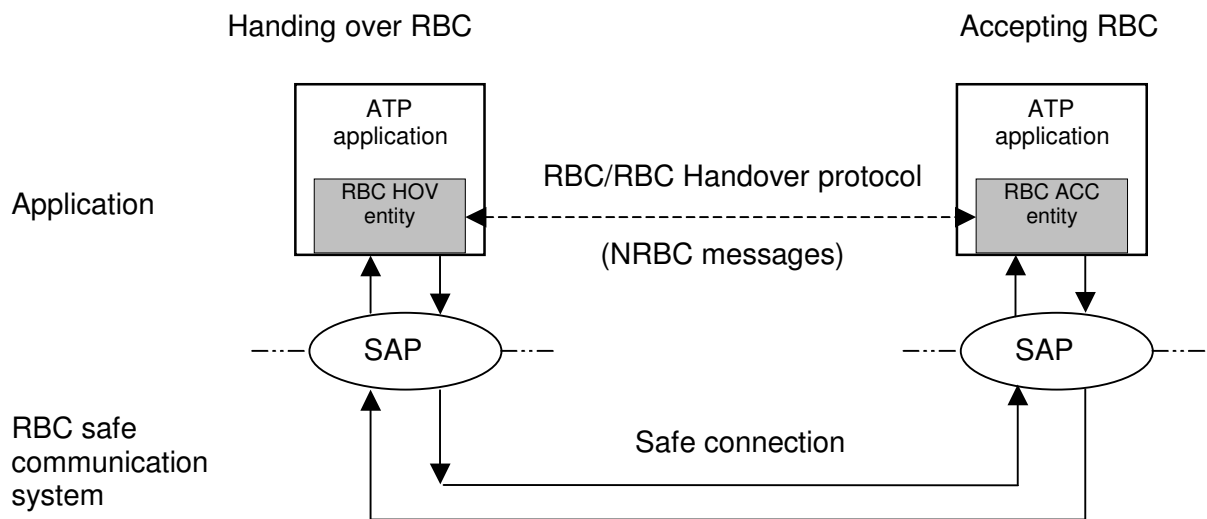

Figure A1 Model of RBC/RBC Communication

- A.1.1.5 The RBC/RBC communication entities of Handing Over RBC and Accepting RBC (RBC_{HOV} / RBC_{ACC} entities) are related to each RBC/RBC communication. Different RBC/RBC communications have simultaneously to be handled for the neighbour RBCs.

A.2 Initialisation of RBC/RBC Communication

- A.2.1.1 Note: The exchange of NRBC messages during the initialisation phase is not necessary.

A.3 Data Transfer

A.3.1.1 The time sequence of Figure A2 shows in which way data are exchanged between RBCs.

A.3.1.2 A NRBC message is included in the user data of data transmission service request.

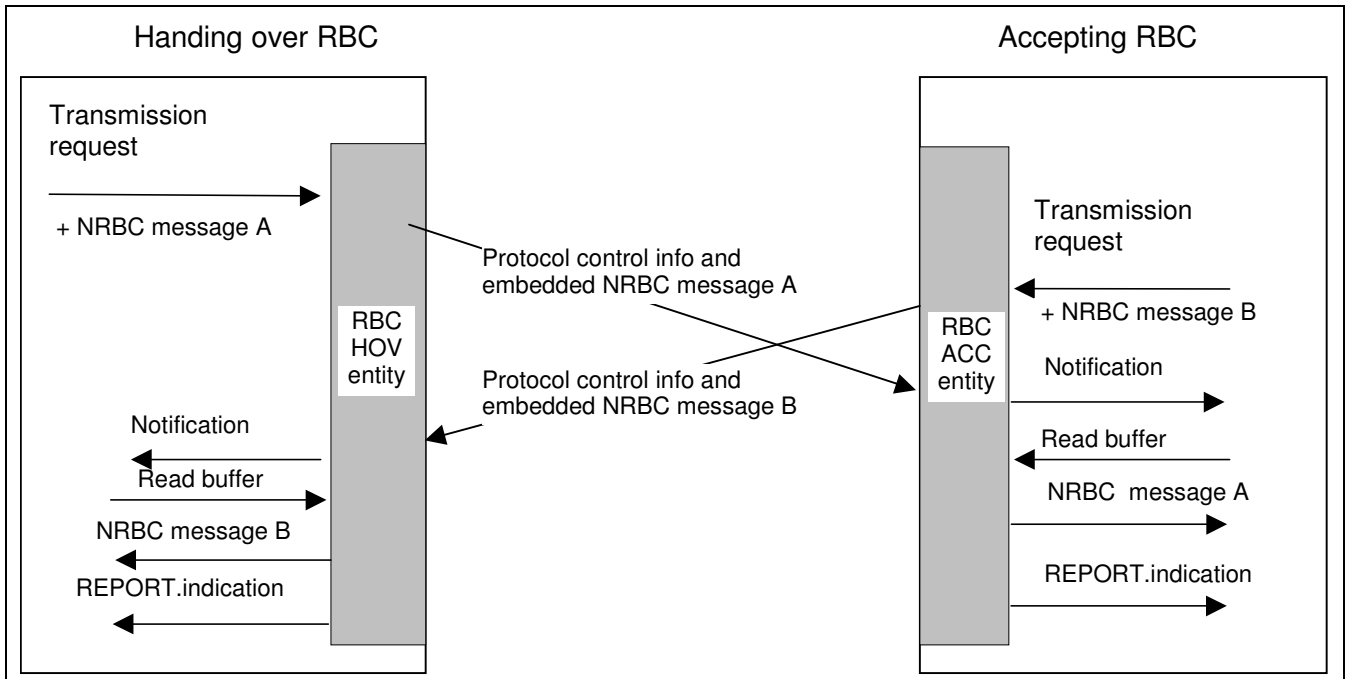
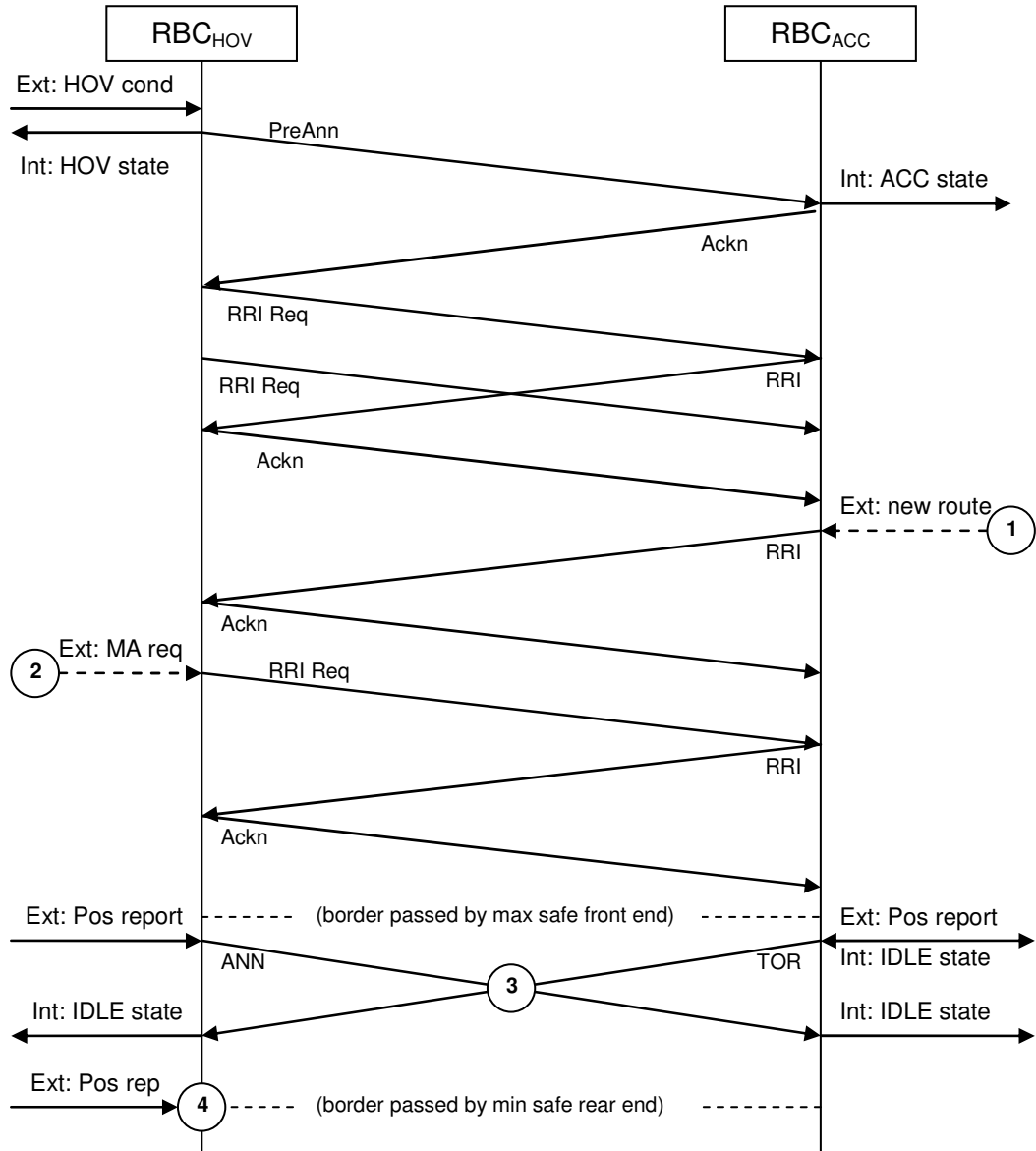

Figure A2 General Time Sequence During Data Transfer

A.3.1.3 The safe data transfer according to EN50159 (like authenticity, integrity and boundaries of NRBC messages) is provided by the RBC-RBC Safe Communication Interface (see [Subset-098]).

A.4 Example of Message Sequence

A.4.1.1 The figure below is an example of a sequence of messages during RBC/RBC handover.



Comments to the numbered events:

- 1: The ACC RBC can send RRI without a RRI Request when there is new info.
- 2: The HOV RBC can send RRI Request initiated by MA request from the train.
- 3: These messages are sent depending on when the position report is received, e.g. if train with only one mobile the ACC RBC receives this report much later.
- 4: This event will cause the HOV RBC to go to IDLE state, if not already in IDLE.

Figure A3 Sequence of Messages During RBC/RBC Handover

A.5 Example of Life Sign

A.5.1.1 The following figure shows an example of timers for communication supervision in case of one ongoing handover transaction. The first sending of a Life Sign message after establishment of the safe connection is not shown.

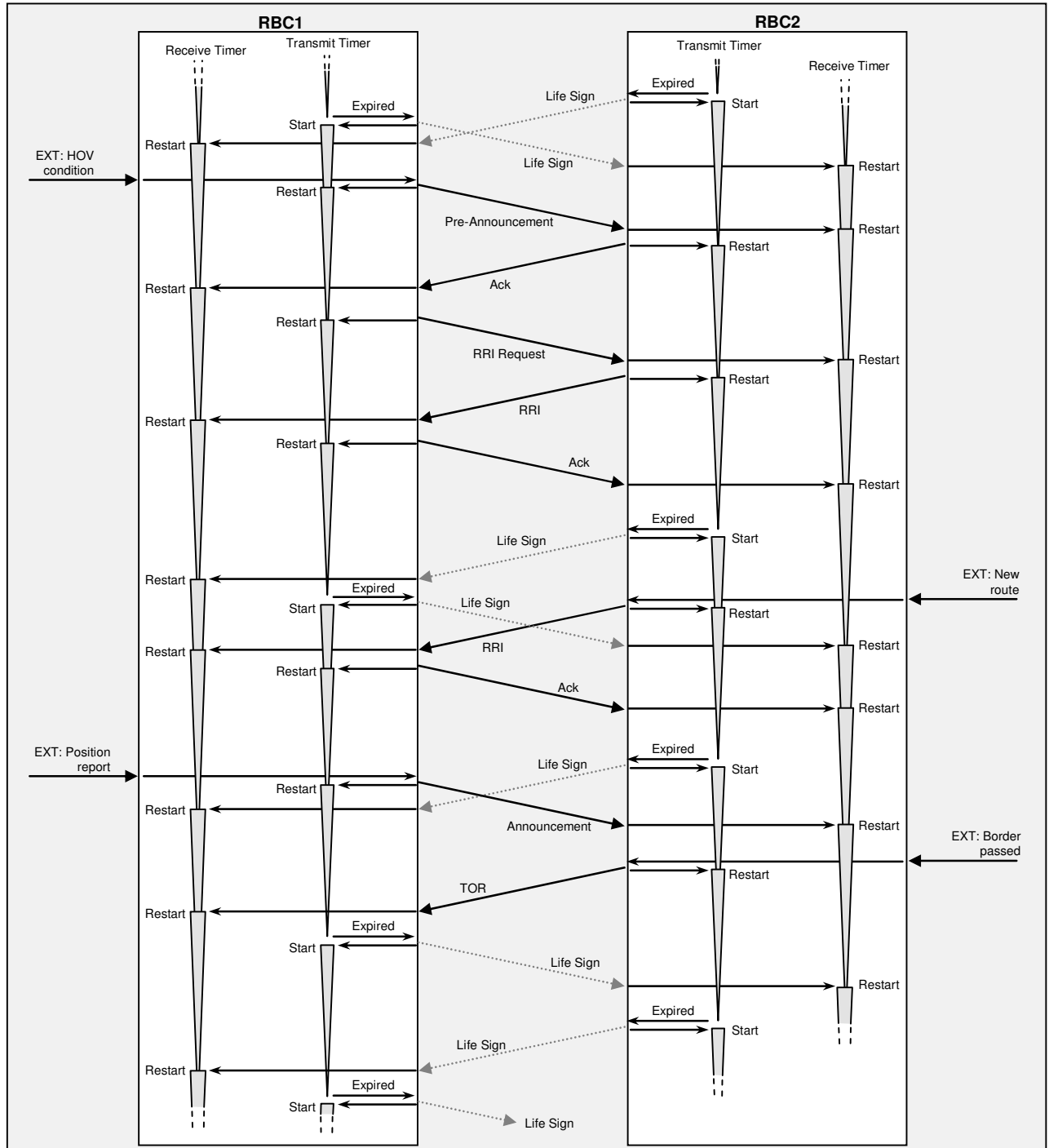

Figure A4 Life Sign



A.6 Error Handling

A.6.1.1 The lower protocol layers of the RBC/RBC communication can provide implementation specific local error reports to the RBC application.



Annex B – Interface Details for RBC X=1

B.1 State Table of Handing Over RBC

B.1.1.1 The following states are defined for one transaction.

Table B1 States of Handing Over RBC

State	Description
IDLE	No RBC/RBC handover is in progress
HOV	An RBC/RBC handover is on-going. The RBC has the role of Handing Over RBC.

B.1.1.2 The following table specifies the incoming events.

Table B2 Incoming Events of Handing Over RBC

Event	Description
HOV condition detected	Handover condition detected
RRI request necessary	Handing Over RBC detects that route related information is required from the Accepting RBC
RRI received	NRBC message "Route Related Information" received
Condition "Border passed by safe front end" detected	Position report received and condition "Border passed by maximum safe front end" detected
TOR received	NRBC message "Taking Over Responsibility" received
Condition "Border passed by safe rear end" detected	Position report received and condition "Border passed by minimum safe rear end" detected
Cancellation condition detected	Condition for cancellation of the RBC/RBC handover transaction is detected in the Handing Over RBC
ACK received	NRBC message "Acknowledgement" has been received
Cancellation received	NRBC message "Cancellation" received
Life Sign received	NRBC message "Life Sign" received
Request for RRI Confirmation received	NRBC message "Request for RRI Confirmation" received
RRI Confirmation condition detected	RRI Confirmation condition detected

Event	Description
New train data received	The Handing Over RBC has received new train data from the ETCS on-board equipment

B.1.1.3 The following table specifies the outgoing events.

Table B3 Outgoing Events of Handing Over RBC

Event	Description
Pre-Announcement	Send NRBC message "Pre-Announcement"
RRI request	Send NRBC message "Route Related Information Request"
ACK	Send NRBC message "Acknowledgement"
Announcement	Send NRBC message "Announcement"
Cancellation	Send NRBC message "Cancellation"
RRI Confirmation	Send NRBC message "RRI Confirmation"
New train data	Send NRBC message "Train Data"

B.1.1.4 The following figure shows the state diagram of the Handing Over RBC:

- a) The states (refer to Table B1)
- b) The incoming events (refer to Table B2)
- c) The state transitions.

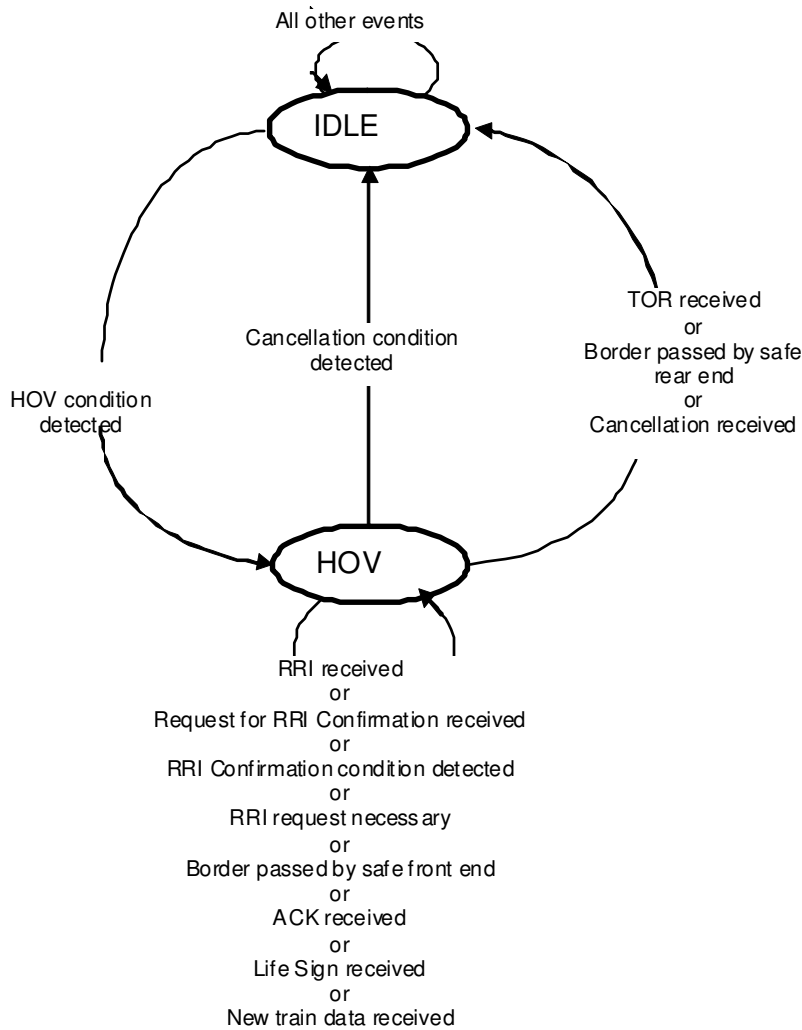

Figure B1 Handing Over RBC State Diagram

B.1.1.5 For each state (see Figure B1) the following table defines for each incoming event what has to happen and which is the next state.

Table B4 Handing Over RBC state transition table

Event	IDLE	HOV
HOV condition detected	Send "Pre-Announcement" → HOV	
RRI request necessary		Send "RRI request" → HOV
RRI received	→ IDLE	Send "Acknowledgement" → HOV
Condition "Border passed by safe front end"	→ IDLE	Send "Announcement" → HOV
TOR received	→ IDLE	→ IDLE

Event	IDLE	HOV
Condition "Border passed by safe rear end"	→ IDLE	→ IDLE
Cancellation condition detected	see Note below this table	Send "Cancellation" → IDLE
ACK received	→ IDLE	→ HOV
Cancellation received	If M_ACK=1: Send "Acknowledgement" → IDLE If M_ACK=0 → IDLE	If M_ACK=1: Send "Acknowledgement" → IDLE If M_ACK=0 → IDLE
Life Sign received	→ IDLE	→ HOV
Request for RRI Confirmation received	→ IDLE	Send "Acknowledgement" → HOV
RRI Confirmation condition detected		Send "RRI Confirmation" → HOV
New train data received	→ IDLE	Send "Train Data" → HOV

B.1.1.6 Note: Cancellation may be repeated, e.g. if acknowledgement was not received.

B.2 State Table of Accepting RBC

B.2.1.1 The following states are defined for one transaction.

Table B5 States of Accepting RBC

State	Description
IDLE	No RBC/RBC handover is in progress
ACC	An RBC/RBC handover is ongoing. The RBC has the role of Accepting RBC.

B.2.1.2 The following table specifies the incoming events.

Table B6 Incoming Events of Accepting RBC

Event	Description
Pre-Announcement received	NRBC message "Pre-Announcement" received

Event	Description
RBC decided to send RRI	Accepting RBC has decided (e.g. Signalling environment has changed) to send NRBC message "Route Related Information"
RRI request received	NRBC message "Route Related Information Request" received
ACK received	NRBC message "Acknowledgement" received
Announcement received	NRBC message "Announcement" received
Condition "Border passed by safe front end" detected	Position report received and condition "Border passed by maximum safe front end" detected
Cancellation received	NRBC message "Cancellation" received
Missing ACK for RRI	Acknowledgement for RRI not received, e.g. a timer expires
Cancellation condition detected	Condition for cancellation of the RBC/RBC handover transaction is detected in the Accepting RBC
RBC decided to send Life Sign	Accepting RBC has decided to send NRBC message "Life Sign"
RBC decided to send Request for RRI Confirmation	Accepting RBC has decided to send NRBC message "Request for RRI Confirmation"
RRI Confirmation received	NRBC message "RRI Confirmation" received
New train data received	NRBC message "Train Data" received

B.2.1.3 The following table specifies the outgoing events.

Table B7 Outgoing Events of Accepting RBC

Event	Description
RRI	Send NRBC message "Route Related Information"
TOR	Send NRBC message "Taking Over Responsibility"
ACK	Send NRBC message "Acknowledgement"
Cancellation	Send NRBC message "Cancellation"
Life Sign	Send NRBC message "Life Sign"
Request for RRI Confirmation	Send NRBC message "Request for RRI Confirmation"

B.2.1.4 The following figure shows the state diagram of the Accepting RBC.

- a) The states (refer to Table B5)
- b) The incoming events (refer to Table B6)
- c) The state transitions

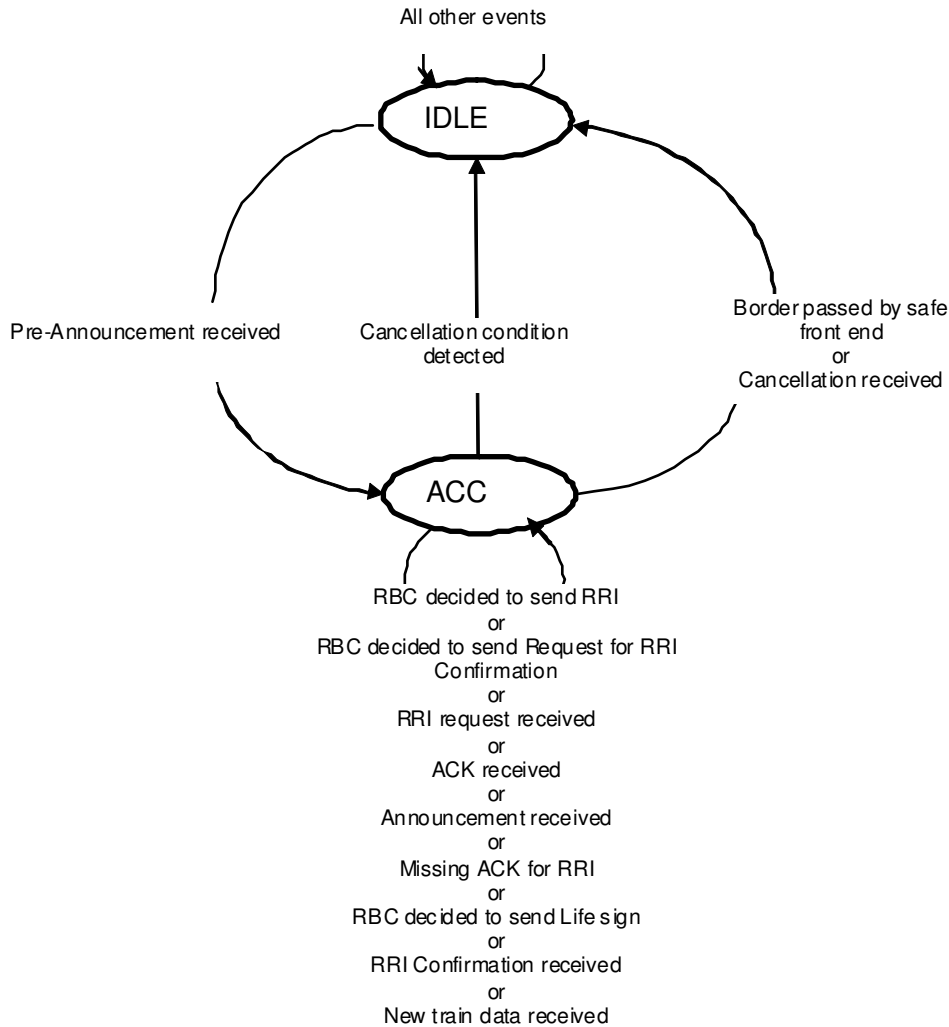

Figure B2 Accepting RBC State Diagram

B.2.1.5 For each state (see Figure B2) the following table defines for each incoming event, what has to happen and which is the next state.

Table B8 Accepting RBC State Transition Table

Event	IDLE	ACC
Pre-Announcement received	Send "Acknowledgement" → ACC	Send "Acknowledgement" → ACC
RBC decided to send a RRI		Send "RRI" → ACC

Event	IDLE	ACC
RRI request received		If M_ACK=1: Send "Acknowledgement" → ACC If M_ACK=0: → ACC
ACK received	→ IDLE	→ ACC
Announcement received	→ IDLE	If M_ACK=1: Send "Acknowledgement" → ACC If M_ACK=0: → ACC
Condition "Border passed by safe front end"	→ IDLE	Send "TOR" → IDLE
Cancellation received	If M_ACK=1: Send "Acknowledgement" → IDLE If M_ACK=0: → IDLE	If M_ACK=1: Send "Acknowledgement" → IDLE If M_ACK=0: → IDLE
Missing ACK for RRI		Send RRI → ACC
Cancellation condition detected	see Note below this table	Send "Cancellation" → IDLE
RBC decided to send Life Sign		Send "Life Sign" → ACC
RBC decided to send Request for RRI Confirmation		Send "Request for RRI Confirmation" → ACC
RRI Confirmation received	→ IDLE	If M_ACK=1: Send "Acknowledgement" → ACC If M_ACK=0: → ACC
New Train Data received	→ IDLE	Send "Acknowledgement" Send "RRI" → ACC

B.2.1.6 Note: Cancellation may be repeated, e.g. if acknowledgement was not received.

B.3 Example of X=1 Life Sign

B.3.1.1 The following figure shows an example of timers for safe connection supervision.
Handing over RBC

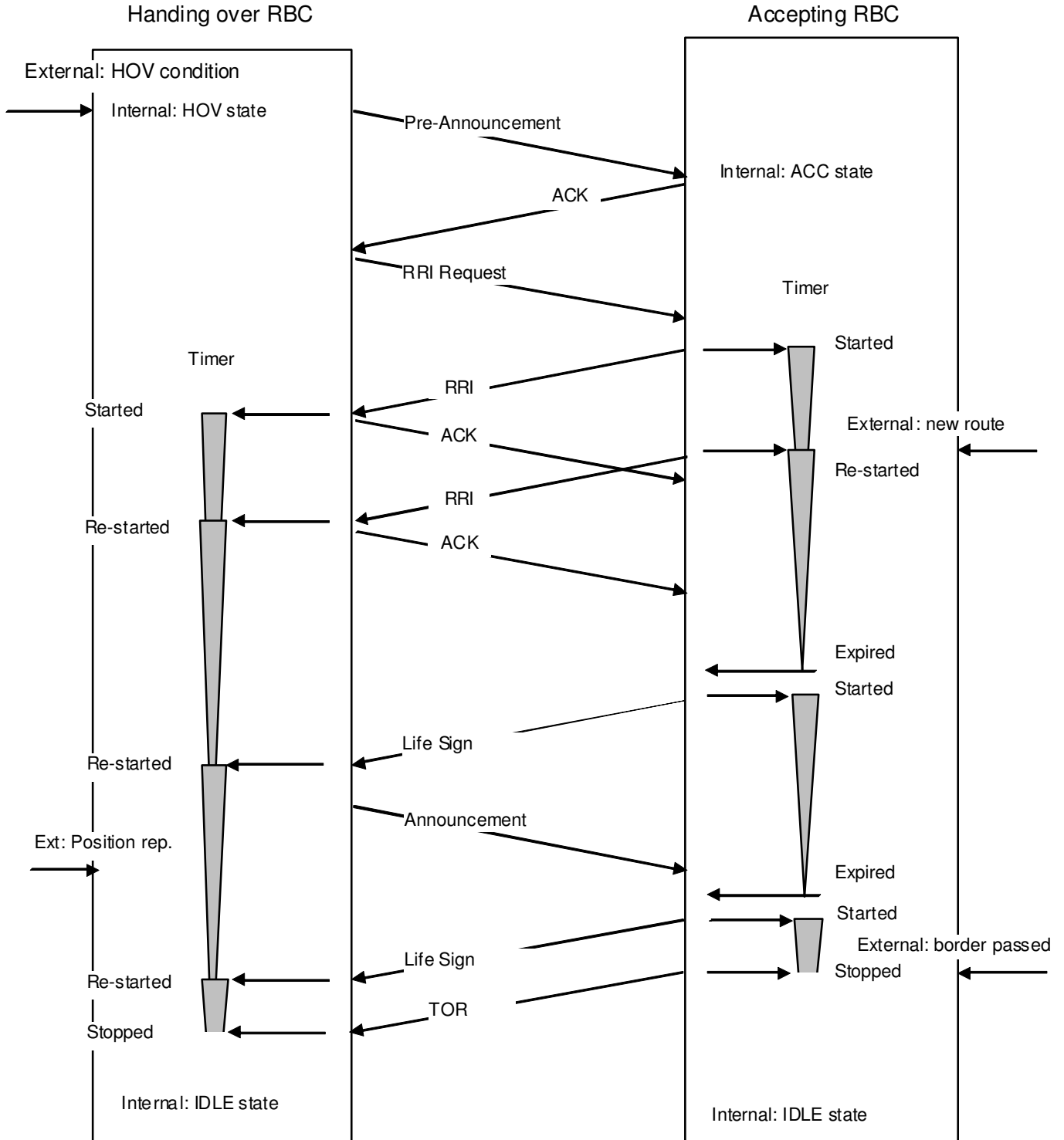

Figure B3 Life Sign



B.3.1.2 Notes:

1. The message receiving timer of the Handing Over RBC will not be started until receiving the first RRI: its task is supervision because of a possible **restrictive** RRI. This could not be the first one.
2. The Life Sign transmitting timer will be started after sending an NRBC message (RRI, ACK or Life Sign): supervision is only necessary during an ongoing transaction.