

ERTMS/ETCS – Class 1

RBC-RBC Safe Communication Interface

REF : **Subset-098**
 ISSUE: 1.0.0
 DATE: 21 May 2007

Company	Technical Approval	Management approval
ALSTOM		
ANSALDO SIGNAL		
BOMBARDIER		
INVENSYS RAIL		
SIEMENS		
THALES		

1. MODIFICATION HISTORY

<i>Issue Number:: Date</i>	<i>Section Number</i>	<i>Modification / Description</i>	<i>Author</i>
0.0.1 :: 10-Jun-05	all	First draft	LK/FH/RB ed.JH
0.0.2 :: 14-Jun-05	all	Updated during the Berlin meeting	MM
0.0.3 :: 7-Jul-05	all	Revised after meeting	JH
0.0.4 13-07-05	all	Updated during the Brussels meeting	MM
0.0.5 :: 13-Sep-05	Added 5.4.2, Annex 7.4, change to SN, Fig11	Decision of Brussels meeting	JH
0.0.6 :: 27-Sep-05		Updated during the Genova meeting	MM
0.0.7 :: 5-Oct-05	6.6.2.1	final review	JH
0.0.8 :: 5-Oct-05	5.4.7, 6.6.2	additional comments	JH
0.0.9 :: 7-Oct-05	5.4.10.1.4	correction	JH
0.1.0 :: 7-Oct-05		update for release	JH
0.1.1 :: 2-Mar-06	3.2, 5.4.2.1.1, fig.7, 5.4.5.3.9, 5.4.9.5.1, 5.5.2.2.5, 3.4, 5.4.9.5.2, 6.4.5.1.5, new § 7.5	Update according to "LOP for subset-098" V.0.0.2	FH+LK
0.2.0 :: 19-Jun-06		update for release	MM
0.2.1 :: 11-Oct-06 0.2.2 :: 08-Nov-06 0.2.3 :: 27-Feb-07	3	This interface specification is based on the Alstom-Ansaldo proposal, complying with the decision of the NPMs in their meeting of the 4 th of May 2004. Unisig re-drafting of paragraph 3.1 - to reflect discussion at the PRG meeting of 4 October 2006 - for approval by the ERTMS User's Group	MM/DG DG DG
1.0.0 :: 21-May-07	3	Approved by ERTMS User's Group for delivery	LK

2. TABLE OF CONTENTS

2.1 Document

1. MODIFICATION HISTORY	2
2. TABLE OF CONTENTS	3
2.1 Document	3
2.2 Figures.....	5
2.3 Tables.....	6
3. INTRODUCTION.....	8
3.1 Purpose and applicability.....	8
3.2 References	8
3.3 Terms and definitions	9
3.4 Abbreviations	9
4. REFERENCE ARCHITECTURE	11
4.1 Overview.....	11
4.2 RBC/RBC Safe Communication Interface	12
4.3 Layer Functions	13
4.3.1 Safe Functional Module.....	13
4.3.2 Communication Functional Module	14
4.4 Classification of transmission systems	14
4.5 Assumptions	14
5. SAFE FUNCTIONAL MODULE	15
5.1 Introduction	15
5.2 Functions of the Safe functional module.....	15
5.3 Euroradio SL implementation	16
5.4 Safe application intermediate sub-layer.....	18
5.4.1 General overview.....	18
5.4.2 Interface to SAI Services	19
5.4.3 Interface to the Euroradio SL.....	20
5.4.4 Message structure	20
5.4.5 SAI Protocol.....	23
5.4.6 Message type field.....	27
5.4.7 Sequence numbering defence technique	27
5.4.8 Triple Time Stamping	31
5.4.9 EC defence technique	44
5.4.10 Error handling	51
5.5 Configuration data and rules.....	52

5.5.1	Introduction.....	52
5.5.2	Connection initiation rules	52
5.5.3	Guideline for TTS parameter definition.....	53
5.5.4	Guideline for EC parameter definition	54
5.5.5	Guideline for error handling	55
5.6	TTS examples.....	56
6.	COMMUNICATION FUNCTIONAL MODULE.....	59
6.1	General.....	59
6.2	Overview.....	59
6.2.1	General description	59
6.3	Functional Characteristics	60
6.3.1	TCP equivalence to Transport Class 2 service and protocol.....	60
6.3.2	Class of Service.....	61
6.3.3	Class A request	61
6.3.4	Class D request	62
6.3.5	Relationship between TS-User and TCP.....	62
6.3.6	Transport Priorities	64
6.4	Transport Layer Emulation using an Adaptation Layer Entity.....	64
6.4.1	General Overview.....	64
6.4.2	Interface Service Definition.....	65
6.4.3	Mapping of X.214 primitives to TCP	68
6.4.4	Addressing.....	69
6.4.5	Adaptation Layer Packet Format (ALEPKT).....	69
6.5	Interface Protocol Definition.....	71
6.5.1	Using TCP/IP to provide ISO Transport Class 2 protocol.....	71
6.5.2	ALE operation.....	74
6.5.3	Data transfer	79
6.5.4	Connection release.....	80
6.6	Operation and Redundancy Management for different Classes of Service.....	84
6.6.1	Class A (optional for implementation).....	84
6.6.2	Class D	88
6.6.3	Summary of ALEPKT.....	89
6.7	Management of Adaptation Layer - ALEPKT Error Handling.....	90
6.8	Lower layers of protocol stack	92
6.8.1	Introduction.....	92
6.8.2	TCP Parameter Negotiation (Mandatory)	92
6.8.3	Network Service Definition	92
6.8.4	Network Protocol	93

6.9	Adaptation Layer Configuration and Management	93
6.9.1	General	93
6.9.2	Timer Parameter	93
6.9.3	Call and ID-Management (Adaptation Layer and TCP)	93
7.	INFORMATIVE ANNEX	94
7.1	TCP Parameter Negotiation	94
7.1.1	TCP Service options	94
7.2	Address Mapping	94
7.3	Data Link Layer	97
7.3.1	Ethernet	97
7.3.2	Media Access Control	97
7.3.3	Wide Area connections	97
7.4	Guideline for Key Management	97
7.4.1	Scope	97
7.4.2	KM Concepts and Principles	97
7.4.3	Phases and parties involved In KMS	98
7.4.4	General Principles	98
7.4.5	Key Hierarchy	99
7.4.6	Key assignment	100
7.4.7	Basic KM Functions	101
7.4.8	Abbreviations and Definitions	102
7.5	Examples of Checksum results	104

2.2 Figures

Figure 1:	Structure of the RBC-RBC safe communication system	11
Figure 2:	Architecture of the RBC-RBC communication system	12
Figure 3:	Time stamp information	19
Figure 4:	Message structure	21
Figure 5:	Structure of the SAI header if TTS used	22
Figure 6:	Structure of the SAI header if EC used	22
Figure 7:	SAI connection process	24
Figure 8:	Disconnection procedure	24
Figure 9:	Procedure for application data exchange	26
Figure 10:	Message numbering	28
Figure 11:	Sequencing errors	30
Figure 12:	OffsetStart message	32
Figure 13:	OffsetAnsw1 message	33

Figure 14: OffsetAnsw2 message	34
Figure 15: OffsetEst message.....	34
Figure 16: OffsetEnd message	35
Figure 17: Clock offset update procedure	37
Figure 18: Application data message.....	39
Figure 19: Triple time stamp principle	40
Figure 20: Time stamping computation	42
Figure 21: Clock offset update procedure	43
Figure 22: Initialisation phase of the EC defence technique	45
Figure 23: ExecutionCycleStart message	46
Figure 24: EC state machine.....	48
Figure 25: Procedure for detection of network delay	51
Figure 26: Example of Clock offset update procedure	57
Figure 27: Example of Time stamp procedure and check.....	58
Figure 28: Protocol stacks used to connect an ERTMS application to its counterpart.....	60
Figure 29: Relationship between a TS-User and two TCP channels	63
Figure 30: Reference message structure.....	64
Figure 31: Example of Communication Functional Module.....	65
Figure 32: Safe Connection establishment: Detailed protocol sequence.....	75
Figure 33: Detailed Data transfer protocol sequence.....	79
Figure 34: Non-disruptive Connection release detailed protocol sequence.....	82
Figure 35: Disruptive Connection release detailed protocol sequence	82
Figure 36: Example of address mapping	96
Figure 37: KM context diagram	99

2.3 Tables

Table 1: Defence techniques in the safe functional module.....	16
Table 2: SaS primitives parameters	17
Table 3: Euroradio SL configuration.....	18
Table 4: Service primitives in TSAP	67
Table 5: Mapping of X.214 primitives to TCP	69
Table 6: ALEPKT information structure.....	70
Table 7: Mapping of Normal Procedure elements of TP2	73
Table 8: Service primitives in TCP	74
Table 9: Connection establishment mapping between TP2 actions/events and TCP.....	78
Table 10: Summary of ALEPKTs	90
Table 11: Error reports	92

Table 12: Key hierarchy 100
Table 13: Use of the defined keys..... 100
Table 14 : Example of Checksum result – all values are in hex..... 104

3. INTRODUCTION

3.1 Purpose and applicability

- 3.1.1.1.1 This document specifies the functional architecture and the protocols for exchange of safety-related messages between RBCs via closed or open networks.
- 3.1.1.1.2 It is applicable to the RBC-RBC safe communication interface .
- 3.1.1.1.3 This specification shall be used for the interface between RBCs from single or different suppliers unless the railway(s), as well as the supplier(s), on both sides of the interface, agree to use a different specification. In case of disagreement by any of the parties, Subset-098 shall be used.

3.2 References

- 3.2.1.1.1 This specification incorporates provisions from other publications by means of dated or undated references. The normative references are cited in the text in the appropriate places, the publications are listed hereafter. As to dated references, subsequent amendments to or revisions of any of these publications apply to this architecture specification only when incorporated by amendment or revision. For undated references, the latest edition of the publication referred to applies.

Name	Date	Description
EN 50159-1	03.01	Safety-Related Communication in Closed Transmission Systems
EN 50159-2	03.01	Safety-Related Communication in Open Transmission Systems
Subset-026	24.02.06	ETCS/ERTMS Class 1; System Requirements Specification, v2.3.0
Subset-037	14.10.05	EuroRadio FIS, v2.3.0
Subset-038	21.12.05	Off-line Key Management FIS, v2.1.11
Subset-039	31.08.05	FIS for RBC/RBC Handover, v2.1.2
Subset-108	08.06.06	ETCS/ERTMS Class 1; Interoperability consolidation on TSI annex A documents, v1.1.0
ITU-T X.214	11.93	Information Technology; Open Systems Interconnection; Transport service definition
ITU-T X.224	11.93	Information Technology; Open Systems Interconnection; Protocol for providing the OSI connection-mode transport service
RFC0791	01.09.81	Internet Protocol v4

Name	Date	Description
RFC2460	12.98	Internet Protocol v6
RFC0793	01.09.81	Transmission Control Protocol v4
ISO/IEC 3309	06.91	Information technology - Telecommunications and information exchange between systems - High-level data link control (HDLC) procedures - Frame structure

3.3 Terms and definitions

The definitions of the standards EN 50159-1 and EN 50159-2 are used in this document. The following terms are used in addition.

Application process

An application layer entity representing a communication relationship.

Execution Cycle

The processing cycle and the associated incremental counter (of a constant processing cycle based computer)

Note that some additional key-management-specific abbreviations and definitions are included in the relevant informative annex.

3.4 Abbreviations

<i>Abbreviation</i>	<i>Meaning</i>
ALE	Adaptation & redundancy management Layer Entity
ALEPKT	ALE packet, PDU exchanged between ALEs
ApPDU	Application PDU
CFM	Communication Functional Module
EC	Execution Cycle
ER	Euroradio
FIS	Functional Interface Specification
IP	Internet Protocol
MAC	Message Authentication Code
PDU	Protocol Data Unit
QoS	Quality of Service
RBC	Radio Block Centre

<i>Abbreviation</i>	<i>Meaning</i>
SaCEPID	Safety Connection End Point Identifier
SAI	Safe Application Intermediate sub-layer
SAP	Service Access Point
SaPDU	Safety Layer Protocol Data Unit
SaS	Safety Service
SFM	Safe Functional Module
SL	Safety Layer
SN	Sequence Number
TCEPID	Transport Connection End Point Identifier
TCP	Transport Control Protocol
TPDU	Transport Protocol Data Unit
TS	Transport Service
TSAP	Transport Layer Service Access Point
TTS	Triple Timestamp

4. REFERENCE ARCHITECTURE

4.1 Overview

- 4.1.1.1.1 A closed network has been defined by EN 50159-1 as “A transmission system with a fixed number or fixed maximum number of participants linked by a transmission system with well known and fixed properties, and where the risk of unauthorised access is considered negligible”.
- 4.1.1.1.2 An open network has been defined by EN 50159-2 as “A transmission system with an unknown number of participants, having unknown, variable and non-trusted properties, used for unknown telecommunication services, and for which the risk of unauthorised access shall be assessed.”
- 4.1.1.1.3 Both network types are considered.
- 4.1.1.1.4 The general structure of an RBC-RBC safe communication system (adapted from EN 50159-2) is shown in Figure 1.

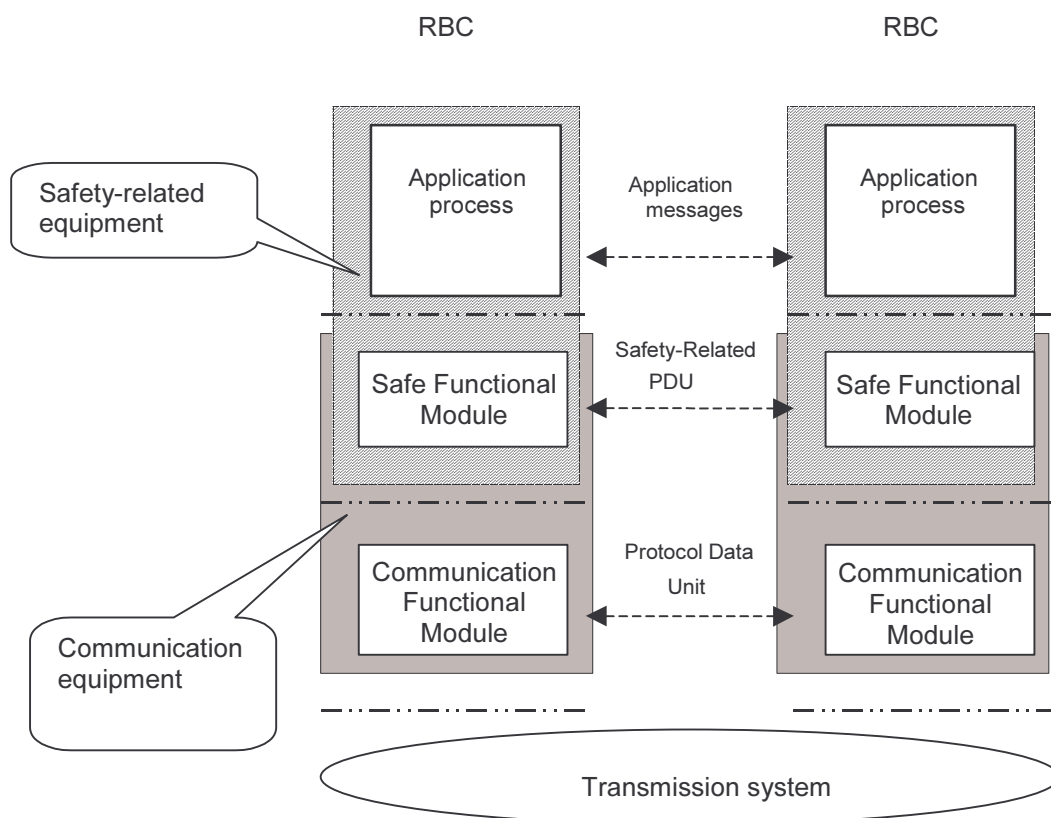

Figure 1: Structure of the RBC-RBC safe communication system

4.2 RBC/RBC Safe Communication Interface

4.2.1.1.1 Without restriction to the implementation of the internal layering this section describes the functional architecture of the RBC-RBC safe communication system. It must not be understood as an implementation in terms of software layers.

4.2.1.1.2 The RBC-RBC safe communication interface is layered. The layers covered by this interface specification are shown in Figure 2 as grey or hatched fields. A functional description for the individual layers is given in the sections below.

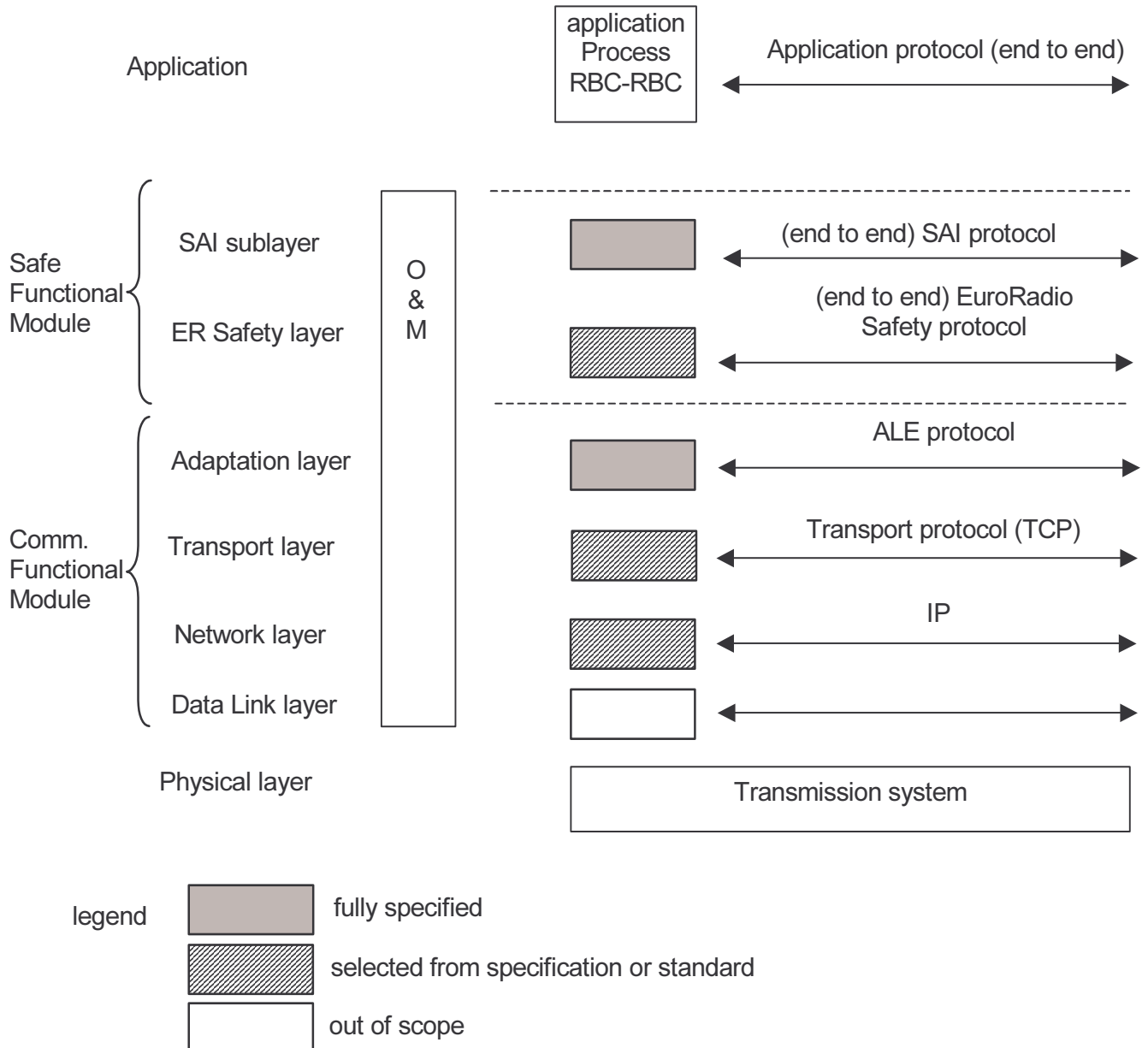

Figure 2: Architecture of the RBC-RBC communication system

- 4.2.1.1.3 The **application protocol** for the transfer of the safety-related information is described by the specification for RBC-RBC handover [Subset-039].
- 4.2.1.1.4 The safe data transfer of safety-related information via non-safe lower layers is dealt with in the **safety layers**. The Safe Application Intermediate (SAI) sub layer is an addition to the Euroradio Safety Layer as specified by Subset-037.
- 4.2.1.1.5 The adaptation **layer** deals with the adaptation between Euroradio Safety Layer and the transport layer and provides the redundancy handling.
- 4.2.1.1.6 The **transport layer** protocol is TCP [RFC0793]. The retransmission function is provided by the normal mechanism of TCP.
- 4.2.1.1.7 The **network layer** protocol is IP [RFC0791].
- 4.2.1.1.8 The **data link layer** will not be specified by this specification.
- 4.2.1.1.9 The **transmission system** i.e. the (public or railway owned) network is out of scope for this specification.
- 4.2.1.1.10 The **Operations and Maintenance** (O&M) stack (e.g. a local diagnostic system) is a matter of an implementation. It is out of scope for this specification.

4.3 Layer Functions

4.3.1 Safe Functional Module

- 4.3.1.1.1 The safety layers provided by this module have to detect and provide adequate defences to the threats as specified by EN 50159-1 and EN 50159-2.
- 4.3.1.1.2 The safety layers realise the following common safety-related transmission functions:
 - Message authenticity (origin and destination)
 - Message sequence integrity
 - Message timeliness
 - Message integrity
 - Reporting of safety relevant errors
 - Configuration management (of the RBC-RBC safe communication protocol stack)
 - Access protection
- 4.3.1.1.3 The EuroRadio safety layer provides:
 - Message authenticity (origin and destination)
 - Message integrity
 - Access protection
- 4.3.1.1.4 The SAI sub layer provides the required additional functions.

- 4.3.1.1.5 Protection against a sequence error is achieved by adding a sequence number field to the user data.
- 4.3.1.1.6 Providing data protection against data obsolescence is achieved by adding a triple time stamp or an EC counter to the user data.
- 4.3.1.1.7 The EC and TTS provide the same level of protection against the delay threat.
- 4.3.1.1.8 The Triple Time Stamp is the standard solution whilst the EC counter will remain as an option. The EC counter option can be used for a specific project, if agreed by the relevant parties to the contract.

4.3.2 Communication Functional Module

- 4.3.2.1.1 The Communication Functional Module provides the non-trusted transmission.
- 4.3.2.1.2 The module provides the following functions:
 - Adaptation between Euroradio Safety Layer and the transport layer
 - Redundancy to fulfil availability requirements
 - Reliable, transparent and bi-directional transfer of data
 - Retransmission of protocol data units, if necessary
 - Monitoring of channel availability

4.4 Classification of transmission systems

- 4.4.1.1.1 To avoid any application constraints for this specification no assumptions about the open transmission system class value shall be made. Thus Class 7 [see EN 50159-2] shall be used as a reference, i.e. the class having the highest safety risk.

4.5 Assumptions

- 4.5.1.1.1 The following are assumed:
 - 'High priority' messages [Subset-037] are not required;
 - Multiplexing is presently not required, nevertheless this feature may be achieved by using one TCP link per logical connection;
 - No explicit flow control is implemented;
 - Safety related errors detected by the SFM may be handled outside SAI;
 - User data not longer than 1000 octets

5. SAFE FUNCTIONAL MODULE

5.1 Introduction

- 5.1.1.1.1 This section specifies the Safe Functional Module (SFM).
- 5.1.1.1.2 It describes only the functional interface to be respected in order to ensure interworking at the safe functional module level.
- 5.1.1.1.3 The safe functional module is composed of:
 - the Euroradio SL
 - the SAI sub-layer
- 5.1.1.1.4 The combination of these two layers provides a complete protection against the threat identified in the document EN 50159-2.

5.2 Functions of the Safe functional module

- 5.2.1.1.1 The safe functional module shall provide safety services compliant with the class 7 open transmission system.
- 5.2.1.1.2 This section specifies how the defence techniques are implemented in the Safe Functional Module.
- 5.2.1.1.3 According to standard EN 50159-2 all possible threats to a generic transmission system are listed below (see EN 50159-2 for definition):
 - Repetition
 - Deletion
 - Insertion
 - Re-sequencing
 - Corruption
 - Delay
 - Masquerade
- 5.2.1.1.4 To reduce the risk associated with those threats identified in the standard, the following safety services shall be provided by the Safety Functional Module (see EN 50159-2 for definitions):
 - Message Authenticity
 - Message Integrity
 - Message Timeliness
 - Message Sequence

5.2.1.1.5 The combination of the Euroradio SL and of the Safe Application Intermediate sub-layer provides a safe protection strategy for an open transmission system.

5.2.1.1.6 The Euroradio SL protects against the following threats:

- Corruption
- Masquerade
- Insertion

5.2.1.1.7 The protection is achieved by the addition of a safety code (Message Authentication Code, or MAC) and a connection identifier (source and destination identifier).

5.2.1.1.8 The SAI protects against the following threats:

- Delay
- Re-sequencing
- Deletion
- Repetition

5.2.1.1.9 The protection is achieved by the addition of a delay defence technique (EC or triple time stamping) and a sequence number.

5.2.1.1.10 The following table illustrates the protection provided by the safe functional module:

<u>Threats</u>	<u>Defences</u>							
	Sequence Number	Time stamp/ EC	Time out	Feed-back message	Source and destination Identifier	Message Identification Proc	Safety code	Cryptographic techniques
Repetition	X							
Deletion	X							
Insertion					X			
Re-sequencing	X							
Corruption								X
Delay		X						
Masquerade								X

Table 1: Defence techniques in the safe functional module

5.3 Euroradio SL implementation

5.3.1.1.1 The Euroradio SL is specified by [Subset-037].

5.3.1.1.2 The service for high priority data of Euroradio is not used. All the data transmissions shall be performed using the normal data service.

5.3.1.1.3 The following table specifies the use of the SaS primitives parameters for the SAI-Euroradio SL interface.

Parameter	Subset-037	SFM use	Comment
Address type	5.2.	Can be used if required	
Network address	5.2.	If provided, identifies the 32-bit destination IP network address and the 16-bit destination TCP port number of the called user.	
Mobile network ID	5.2.	Not used	
Calling ETCS ID type	5.2.	RBC ETCS ID type	
Calling ETCS	5.2.	ETCS ID of the RBC initiating the connection.	
Responding ETCS ID type	5.2.	RBC ETCS ID type	
Responding ETCS ID	5.2.	ETCS ID of the RBC receiving the connection request	
Application type	5.2.	See application types defined in Subset-037.	0001 1011 for RBC-RBC communication
Quality of service class	5.2.	The QoS field can be used to indicate the Class of Service used to establish the connection.	Classes of Service A and D are available.
SaCEPID	5.2.	The SaCEPID is a parameter provided locally to identify each safe connection.	

Table 2: SaS primitives parameters

5.3.1.1.4 The implementation of the interface between the SAI and the Euroradio SL is a local matter.

5.3.1.1.5 The following table specifies the configuration of the Euroradio SL for the RBC-RBC Safe Communication Interface:

Parameter	Subset-037	SFM value	Comment
Maximum length of SaS user data	5.3.	for RBC-RBC hand over: 1000 bytes	
T _{estab}	7.2.5.3.	max. applied value: 40 sec	applied value for interworking with Euroradio recommended 40 sec, lower values are possible for RBC to

			RBC communication (see also §6.9.2.1.1)
--	--	--	---

Table 3: Euroradio SL configuration

5.4 Safe application intermediate sub-layer

5.4.1 General overview

5.4.1.1.1 The safe application intermediate sub-layer provides:

- data protection by sequence number and time stamping/EC counter
- the interface to the application
- the interface to the Euroradio SL

5.4.1.1.2 Data protection against repetition, deletion and re-sequencing shall be achieved by adding a sequence number field to the user data.

5.4.1.1.3 Providing protection against obsolescence is achieved adding a triple time stamp or an EC counter to the user data.

5.4.1.1.4 The time stamping defence technique is founded on the clock-offset computation between the sender and the receiver.

5.4.1.1.5 To allow the clock offset estimation between the sender and the receiver, an initialisation procedure shall be performed. This initialisation procedure requires the definition of a message type in the SAI header.

5.4.1.1.6 Considering a sender device sending a data message to a receiver device, this triple time stamping method consists of adding:

- the sender time stamp for the data transmission;
- the receiver time stamp of the last message sent by the receiver to the current sender;
- sender time stamp at the last receiver message received by the sender.

5.4.1.1.7 The next figure illustrates the time stamp procedure:

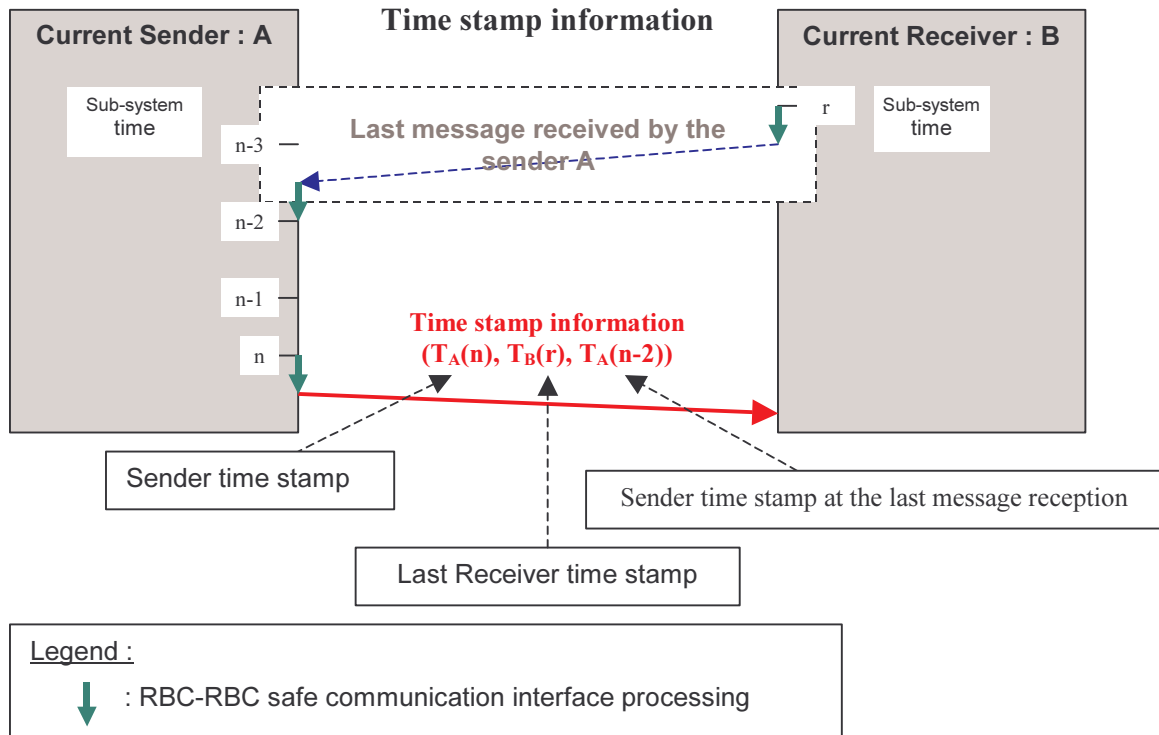

Figure 3: Time stamp information

- 5.4.1.1.8 An alternative defence technique based on the EC is defined, that shall be used when the triple time stamping method is not used. The EC defence technique is based on the addition of the EC counter to the user data in order to check the age of the information.
- 5.4.1.1.9 This method requires also an initialisation phase. During the initialisation step, the EC period of each entity is sent to the peer entity.
- 5.4.1.1.10 The EC and the triple time stamping defence techniques shall be mutually exclusive.

5.4.2 Interface to SAI Services

- 5.4.2.1.1 The safe services provided by the SFM are defined by means of safe service primitives with their corresponding parameters at the Safety Service Access Point.
- 5.4.2.1.2 Only the functional specification is provided, the primitive implementation is a local matter and does not impact on RBC interworking.
- 5.4.2.1.3 SAI connection set-up services:
- SAI-CONNECT.request initiates the establishment of a connection at the SAI level.
 - SAI-CONNECT.indication is used by the called SAI entity to inform the called SAI user about the SAI connection establishment request.
 - SAI-CONNECT.response is used by the responding SAI user to accept the connection to the SAI entity.

- SAI-CONNECT.confirm is used by the initiating SAI entity to inform the calling SAI user about the successful establishment of the SAI connection after a response of the called peer entity was obtained.

5.4.2.1.4 SAI data transfer services:

- SAI-DATA.request is used by an SAI user to transmit application data to the peer entity.
- SAI-DATA.indication indicates to the SAI user that data have been received successfully from the peer entity.

5.4.2.1.5 SAI connection release services:

- SAI-DISCONNECT.request is used by the SAI user to enforce a release of the SAI connection
- SAI-DISCONNECT.indication is used to inform the SAI user about an SAI connection release.

5.4.3 Interface to the Euroradio SL

5.4.3.1 The safe application intermediate sub-layer is functionally above the Euroradio SL.

5.4.3.2 The re-use of the Euroradio SL constrains the SAI design. To interface the Euroradio SL, the SAI shall be able to be interfaced with the “Interface to safe service” specified in Subset-037.

5.4.4 Message structure

5.4.4.1.1 The next figure illustrates the message structure.

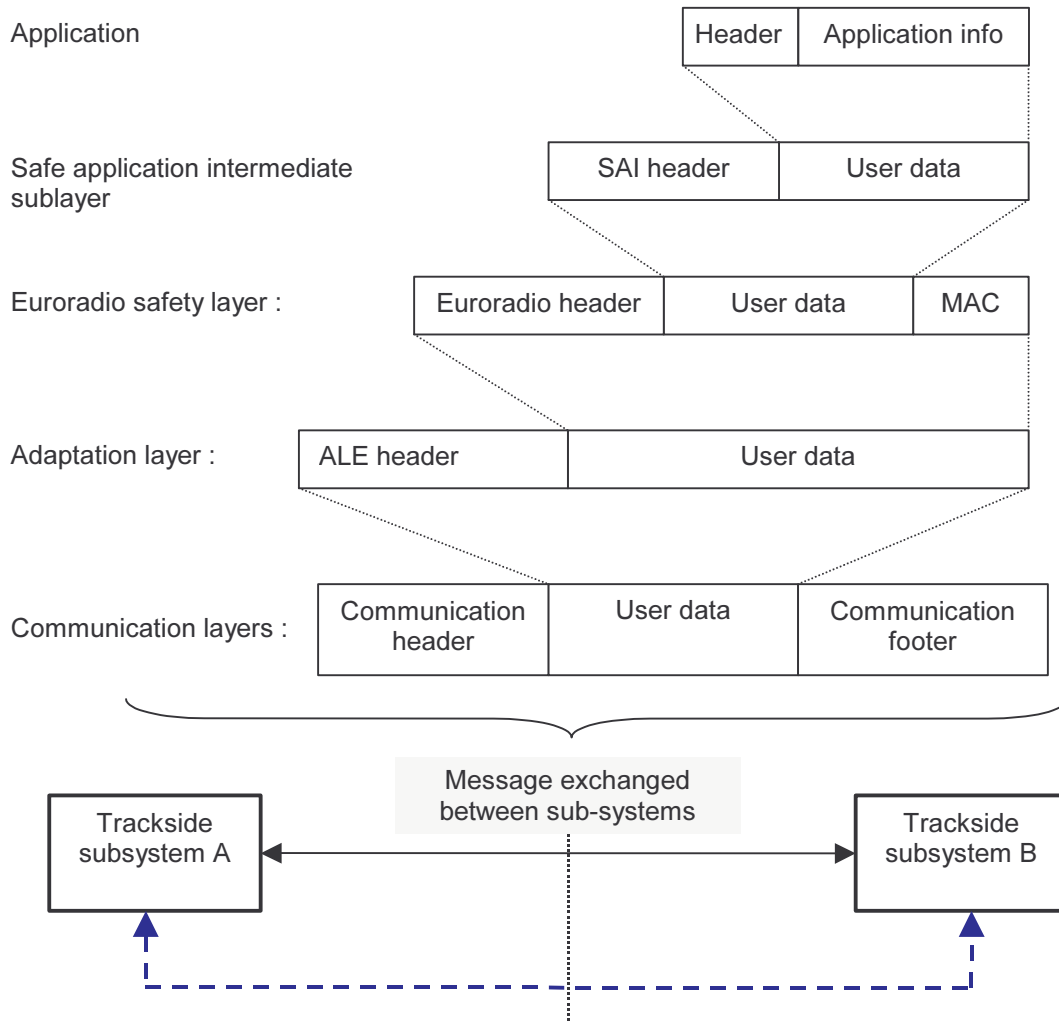

Figure 4: Message structure

5.4.4.1.2 The SAI header structure depends on the message type.

5.4.4.1.3 Two different cases are considered:

- the SAI header is applicable to the transmission of safe data (see Subset-037).
- for the safe connection management only the Euroradio SL is used.

5.4.4.1.4 The structure of the header added by the safe application intermediate sub-layer, in case of safe data transfer, is the following:

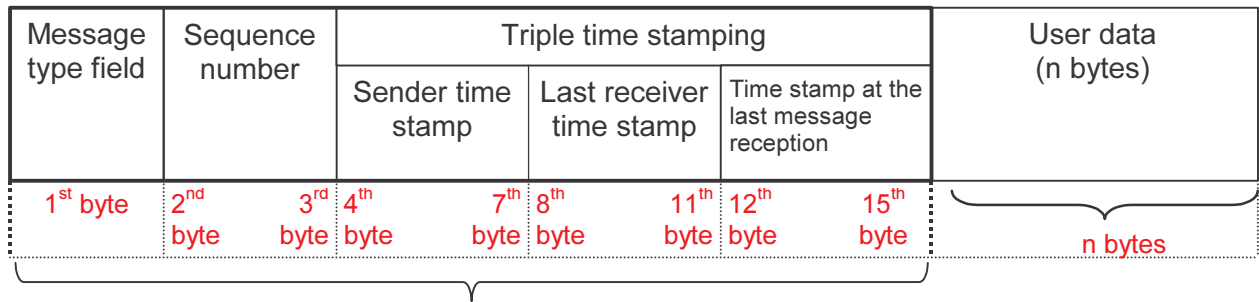

SAI header in case of application data transmission

Figure 5: Structure of the SAI header if TTS used

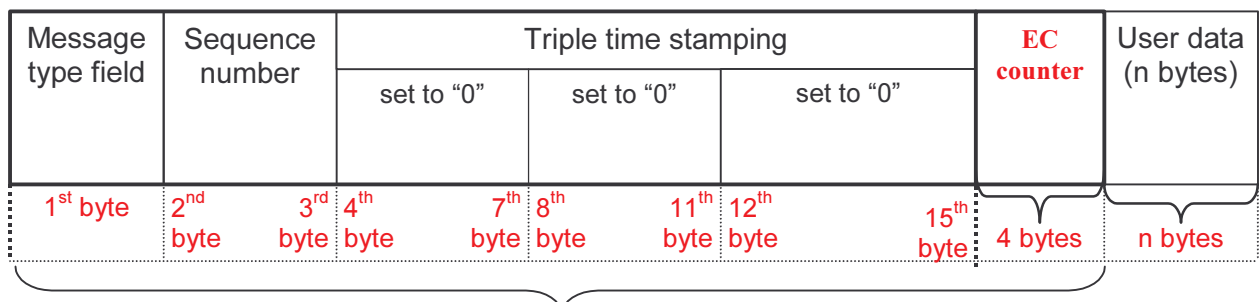

SAI header in case of application data transmission

Figure 6: Structure of the SAI header if EC used

- 5.4.4.1.5 All the fields of the safe application intermediate sub-layer header shall be coded using the Big Endian data representation.
- 5.4.4.1.6 The “message type field” shall identify the message type. This field is coded on 1 byte.
- 5.4.4.1.7 The “sequence number field” shall be used to define the sequence number using two bytes.
- 5.4.4.1.8 The “sender time stamp field”, if TTS is used, shall indicate the time stamping of the sender at the time of message delivery to the local Euroradio SL entity. The sender time stamping is coded on 4 bytes.
- 5.4.4.1.9 The “last receiver time stamp field”, if TTS is used, shall contain the time stamp of the last message generated by the “receiver” transmitted from the receiver to the sender, except for the OffsetStart message (see §5.4.8.4). This time stamp is coded on 4 bytes.
- 5.4.4.1.10 “Time stamp at the last message reception”, if TTS is used, shall indicate the local time stamp when the last received message is delivered by the local Euroradio SL entity,

except for the OffsetStart message (see §5.4.8.4). This time stamp is coded on 4 bytes.

- 5.4.4.1.11 The EC counter field shall be used and present in the header only if the EC defence technique is used.
- 5.4.4.1.12 The EC counter shall be coded on 4 bytes.
- 5.4.4.1.13 As the EC and TTS defence techniques shall be mutually exclusive, the fields related to the TTS defence technique are not checked if the EC defence technique is used. The value of the "TTS" fields are set to "0".

5.4.5 SAI Protocol

5.4.5.1 Connection procedure

- 5.4.5.1.1 The next figure represents the connection procedure between two devices.

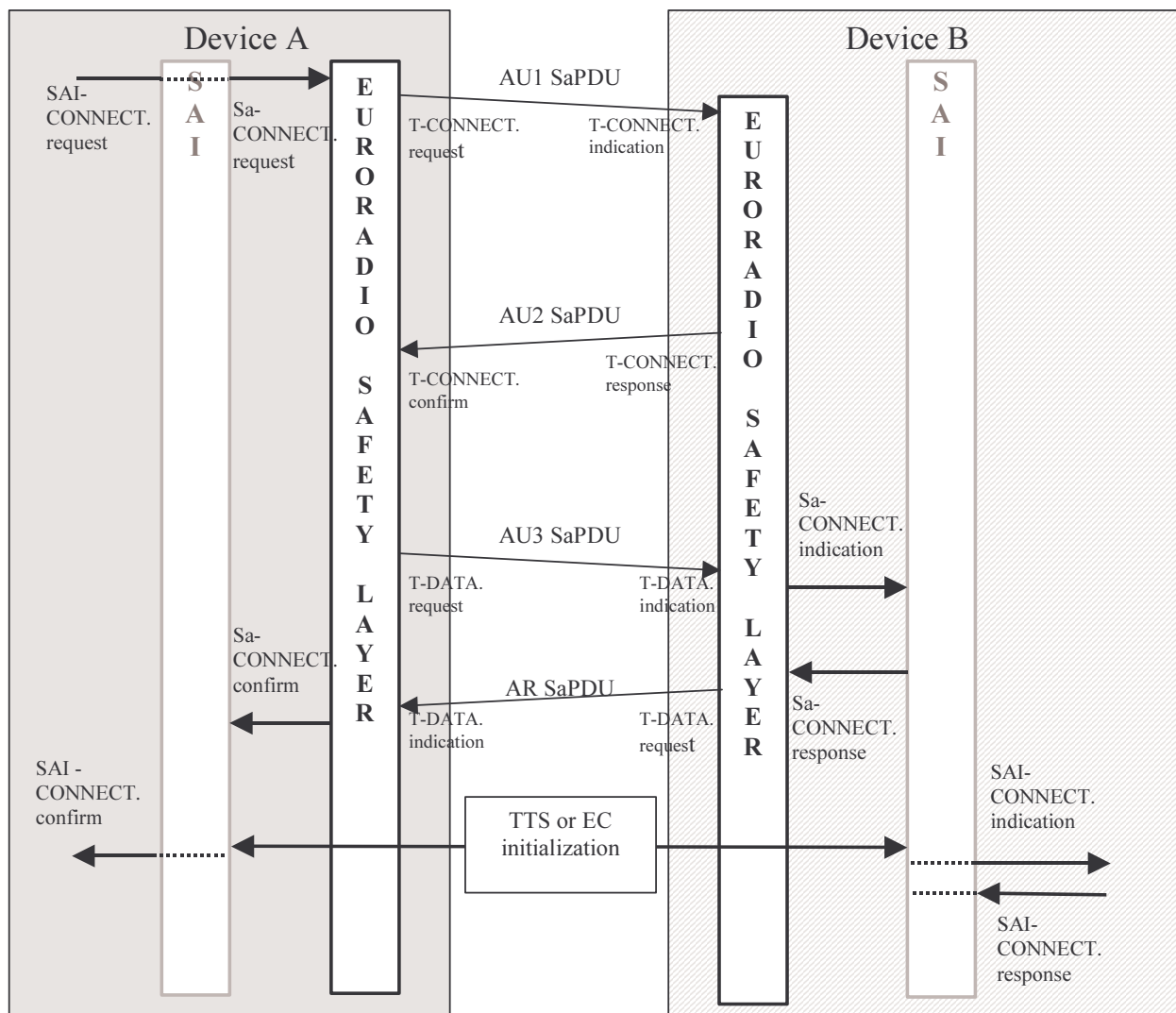

© This document is confidential and restricted to
ALSTOM * ANSALDO SIGNAL * BOMBARDIER * INVENSYS RAIL * SIEMENS * THALES

Figure 7: SAI connection process

5.4.5.1.2 The SAI- service primitives shall be mapped onto Sa-service primitives for connection establishment.

5.4.5.2 Disconnection procedure

5.4.5.2.1 The next figure describes the disconnection procedure between two devices.

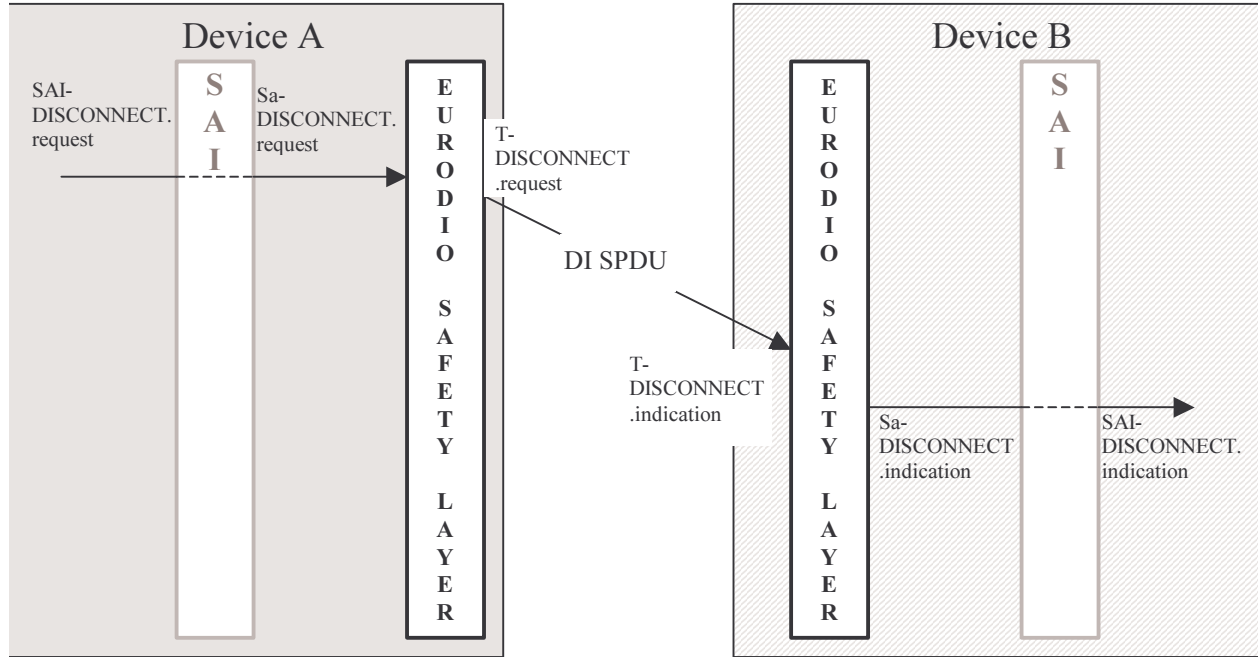

Figure 8: Disconnection procedure

5.4.5.2.2 The SAI-service primitives shall be mapped onto SA-primitives for disconnection .

5.4.5.3 Procedure for exchange of application data

5.4.5.3.1 For the transmission of application data messages, the following process shall be applied.

5.4.5.3.2 Using the SAI-DATA.request, the application can send data to the peer entity (see Subset-037).

5.4.5.3.3 Using the SAI-DATA.request, the SAI sub-layer shall be able to identify the SaCEPID of the connection.

5.4.5.3.4 The SAI sub-layer shall add, in the SAI header, to the application data:

- the message type for the application data exchange;
- the sequence number;
- the TTS fields. The time stamp shall be set to “0” if the EC defence technique is used;
- the EC counter and version, only if the EC technique is used.

- 5.4.5.3.5 The SAI sub-layer shall hand over the application data to the Euroradio SL using the Sa-DATA request primitive, the Sa User data parameter being composed of the concatenation of the message type, sequence number, the TTS fields and the EC fields. The EC fields are present only if the EC defence technique is used.
- 5.4.5.3.6 For the reception of the application data messages, the following process shall be applied.
- 5.4.5.3.7 Using the Sa-DATA.indication, the Euroradio SL can pass data to the application, after the processing by the SAI layer (see Subset-037).
- 5.4.5.3.8 The Sa-DATA.indication shall provide the SaCEPID.
- 5.4.5.3.9 The Sa user data parameter is composed of:
- Message type for the application data exchange;
 - Sequence number;
 - TTS fields. The time stamp shall be set to "0" if the EC defence technique is used;
 - EC counter, only if the EC technique is used.
- 5.4.5.3.10 The Message type field shall be one of the ones defined for the exchange of application data.
- 5.4.5.3.11 The SAI shall check the sequence number before the EC counter or TTS.
- 5.4.5.3.12 If the EC defence technique is used, the TTS fields are not checked and only the EC fields shall be checked.
- 5.4.5.3.13 If the TTS defence technique is used, the TTS fields shall be checked.
- 5.4.5.3.14 If all the checks are performed successfully, the application data and the SaCEPID shall be passed to the application using the SAI-DATA.indication.
- 5.4.5.3.15 The following figure illustrates the application data exchange:

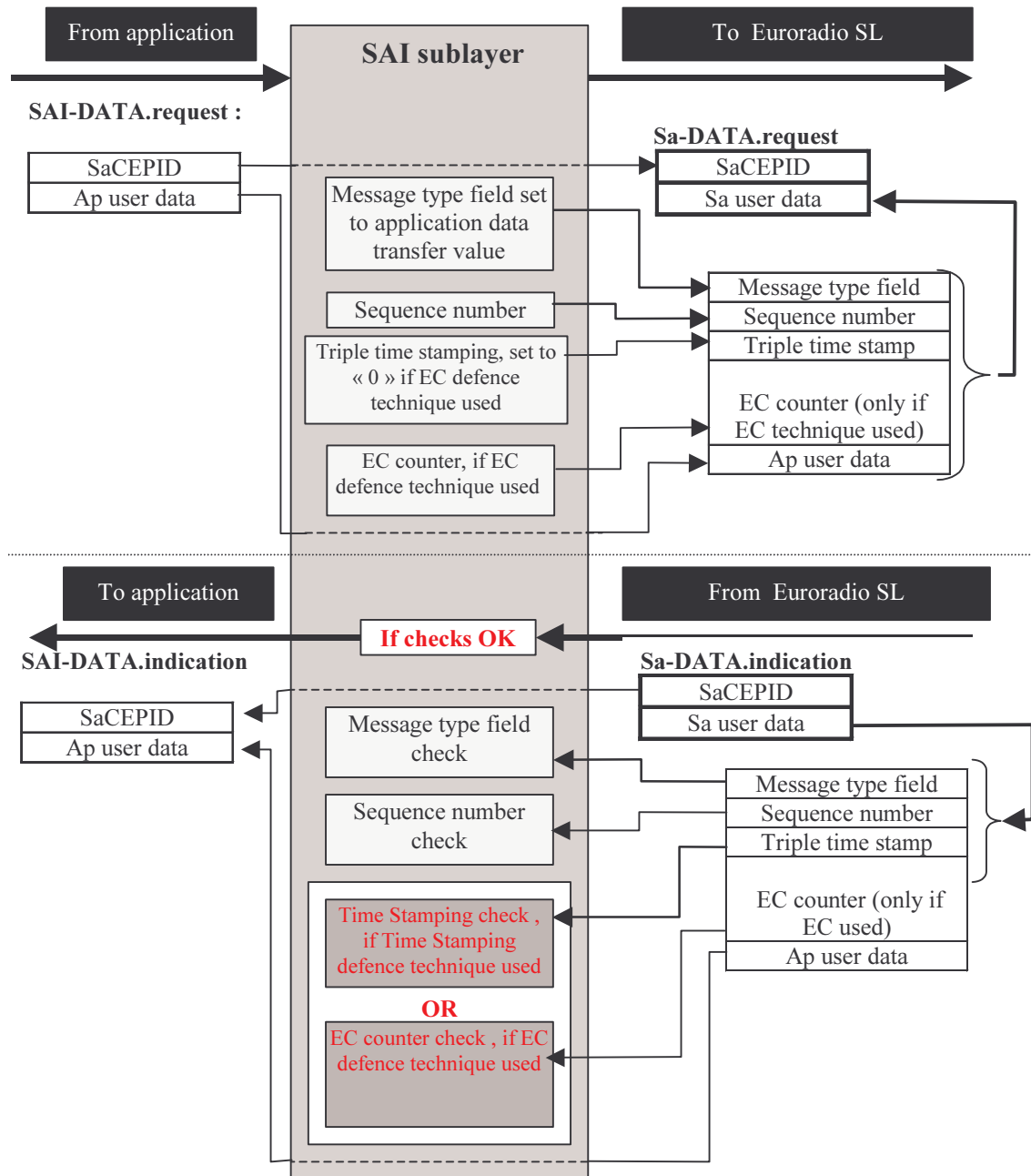

Figure 9: Procedure for application data exchange

5.4.5.4 SAI management messages

- 5.4.5.4.1 The SAI implements some specific procedures to ensure the protection of the message by the TTS or EC counter (see sections 5.4.8.5, 5.4.8.7, 5.4.9.3 and 5.4.9.6). During these procedures, some management messages, specific to the SAI, are exchanged between the two SAI sub-layers.
- 5.4.5.4.2 The SAI management messages are identified by a specific value of the message type field or by the use of data transfer messages without any application data.

- 5.4.5.4.3 The SAI management messages shall be exchanged between SAI sub-layers using the Sa-DATA.request and Sa-DATA.indication primitives.
- 5.4.5.4.4 The sequence number, EC and TTS fields shall be processed in the same way as the procedure used for exchange of application data.
- 5.4.5.4.5 For the message transmission, the value of message type field shall be selected in relation with the type of management message. Depending on the management message type, the user data could come from the application layer or be computed by the SAI itself. If no application data is transmitted to the peer application layer, the SAI layer shall be able to select the proper SaCEPID for the management message.
- 5.4.5.4.6 Depending on the type of management message received by the SAI, the user data will be processed by the SAI itself, accordingly to the message type, or transferred, with the SaCEPID, to the application as application data.

5.4.6 Message type field

- 5.4.6.1.1 Ten message types are defined, six for the TTS, four for the EC counter.
- 5.4.6.1.2 The message types for the TTS defence technique shall be compliant with the following list:

OffsetStart message (1 st message for the clock offset estimation):	1
OffsetAnsw1 message (2 nd message for the clock offset estimation):	2
OffsetAnsw2 message (3 rd message for the clock offset estimation):	3
OffsetEst message (4 th message for the clock offset estimation):	4
OffsetEnd message (5 th message for the clock offset estimation):	5
Application message protected by TTS:	6

- 5.4.6.1.3 The message types in hexadecimal for the EC defence technique shall be compliant with the following list:

ExecutionCycleStart message:	81
Application message protected by EC defence technique:	86
Application message, protected by EC, with Request of Acknowledge:	87
Application message, protected by EC, with Acknowledge:	88

5.4.7 Sequence numbering defence technique

- 5.4.7.1.1 The sequence number field shall be coded on 2 bytes (big Endian).
- 5.4.7.1.2 The sequence number has a value from 0 to 65535.
- 5.4.7.1.3 The sequence numbers shall be independent for each communicating direction.

- 5.4.7.1.4 There is no requirement for the sequence number initialisation. The receiver shall accept any sequence number in the first sequence numbered message received from the peer entity.
- 5.4.7.1.5 It shall not check that the first sequence number received has a specific value. It has only to check the sequence number difference with the previous message.
- 5.4.7.1.6 If the sequence number value is different of the maximum value, the sequence number shall be incremented by one at each new message transmission in the same direction.
- 5.4.7.1.7 Once the sequence number value reaches the maximum value, the value of the sequence number at the next message transmission shall be set to "0".
- 5.4.7.1.8 The next figure illustrates the message numbering between two devices:

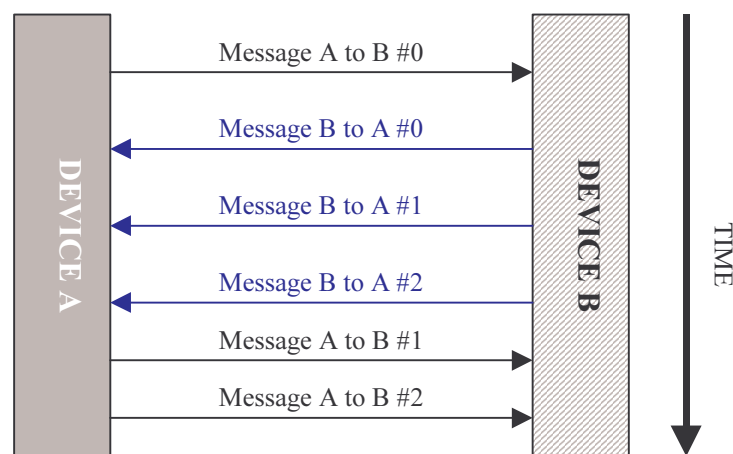

Figure 10: Message numbering

5.4.7.2 Sequencing errors

- 5.4.7.2.1 The following sequencing errors shall be detected:
 - message repetition;
 - message deletion;
 - message re-sequencing.
- 5.4.7.2.2 In the case of an error being detected, the SAI is not able to take any action to recover the missing data.
- 5.4.7.2.3 A parameter N is defined for the message sequence check. N-1 is the number of missing messages allowed. N has to be configured. The value of N shall be equal or greater to 1.
- 5.4.7.2.4 If the received SN is not equal to the SN of the last accepted message + 1 it is treated as a message sequence error.

- 5.4.7.2.5 The message shall be discarded and the safe connection shall be released, if the received SN is greater than the SN of the last accepted message + N.
- 5.4.7.2.6 If the received SN is greater than the SN of the last accepted message + 1 and less than or equal to the SN of the accepted message + N, the application data in this message is not discarded, and this event is handled according to the specified error handling (see §5.4.10.1.2).
- 5.4.7.2.7 The message shall be discarded if the received SN is less than or equal to the SN of the last accepted message.
- 5.4.7.2.8 The reaction to the sequence number error shall comply with the SAI error handling procedure (see § 5.4.10).
- 5.4.7.2.9 The next figure illustrates the behaviour of the sequence numbering defence technique in the case of repeated, deleted or re-sequenced messages, in this case with N=3, that is, the number of allowed missing messages is 0,1 or 2.

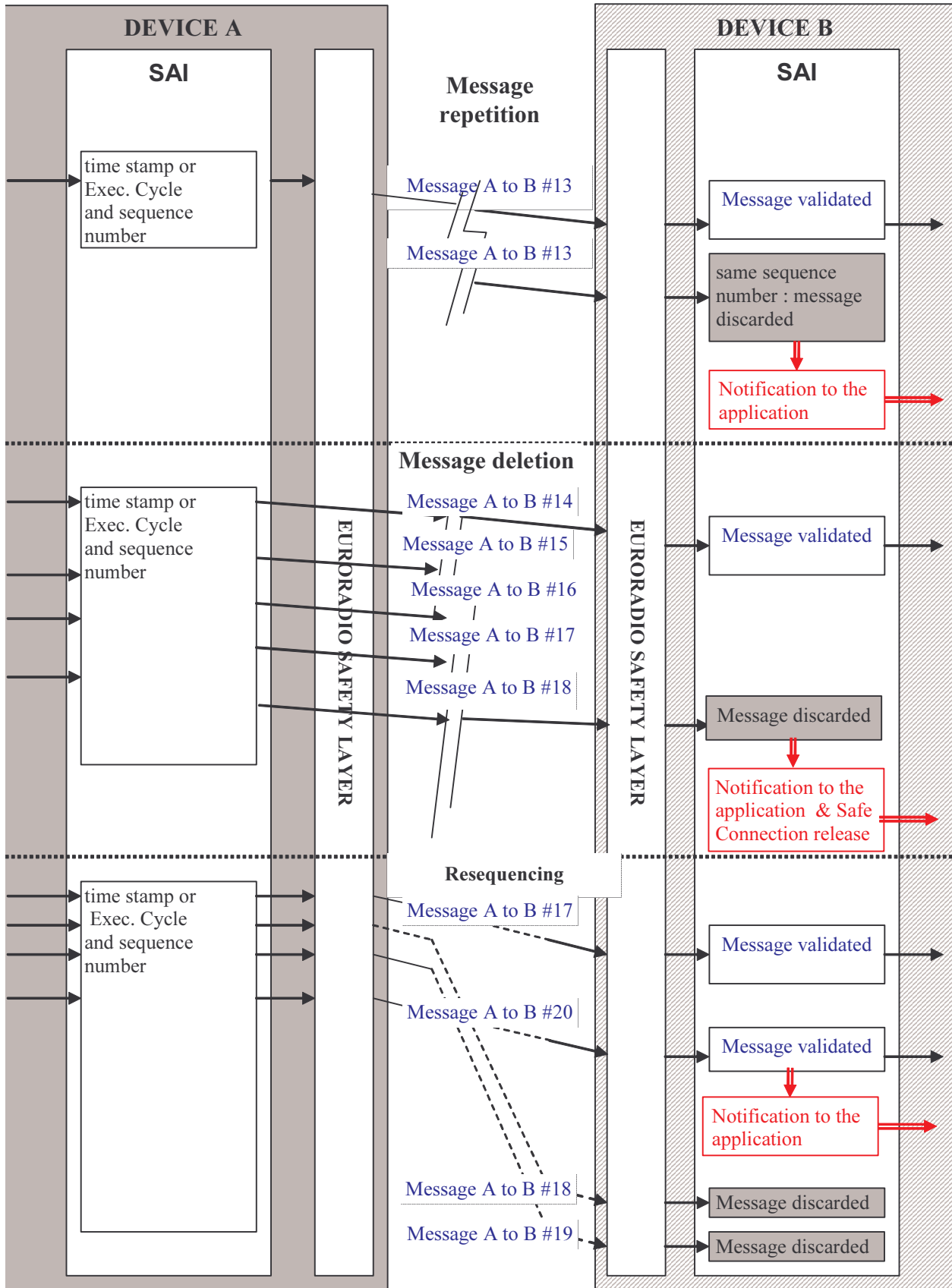

Figure 11: Sequencing errors

5.4.8 Triple Time Stamping

5.4.8.1 Introduction

- 5.4.8.1.1 This time stamping procedure is based on the clock-offset estimation between the sender and the receiver. The clock-offset estimation shall be initiated after the safe connection establishment and before the application data exchange.
- 5.4.8.1.2 The knowledge of the clock offset between the two devices allows them to estimate, in a safe way, the time validity of the application data, without making any assumption about the remote device temporal cycle and/or the network characteristics.
- 5.4.8.1.3 The time stamping tuning procedure (clock offset update procedure) consists of the exchange of five messages between the two devices. Using this procedure, each device shall estimate the clock offset between its internal clock and the one of the peer device.
- 5.4.8.1.4 All the application messages shall be time stamped using a triple time stamp.
- 5.4.8.1.5 The second and third time stamps are used, only to compute and update the clock offset estimation. The first is used for the clock-offset estimation and update, but also to compute the time validity of the application data.
- 5.4.8.1.6 On receipt of a message, the receiver shall adapt the sender transmission time stamp to the receiver clock using the clock offset estimation and then compute the validity time of the application data.
- 5.4.8.1.7 It is a matter for the receiver sub-system to manage the “zero crossing” of the time stamp information coming from the sender.
- 5.4.8.1.8 Periodically, the estimation of the clock offset between the two devices shall be updated using the “Clock offset update” procedure.

5.4.8.2 Time stamping format

- 5.4.8.2.1 The time stamping shall be big-endian, coded on 32 bits. The time stamping format shall be the same as the one defined for the EVC-RBC communication (see T_TRAIN definition in Subset-026-7).
- 5.4.8.2.2 The least significant bit time value is equal to 10 ms.

5.4.8.3 Clock offset estimation principles

- 5.4.8.3.1 The knowledge of the clock offset allows a device to estimate the time validity of messages exchanged between itself and another device.
- 5.4.8.3.2 The clock-offset estimation is done at the safe connection initialisation. The clock offset update procedure shall be performed before the exchange of the first application message.

- 5.4.8.3.3 The device that initiates the safe connection shall start the clock offset update procedure.
- 5.4.8.3.4 The clock-offset estimation consists in the exchange of 5 messages between the two entities. The entity initiating the clock offset update procedure is called the “initiator”, and the other, the “responder” entity.
- 5.4.8.3.5 Using the first two messages, the initiator device shall compute a maximum and a minimum clock offset between the two devices.
- 5.4.8.3.6 Using the second and third messages, the responder device shall compute the maximum and minimum clock offset between the two devices.
- 5.4.8.3.7 The fourth and fifth messages are used for the validation of the clock offset estimations.

5.4.8.4 Clock offset update messages

5.4.8.4.1 The OffsetStart message structure shall be the following:

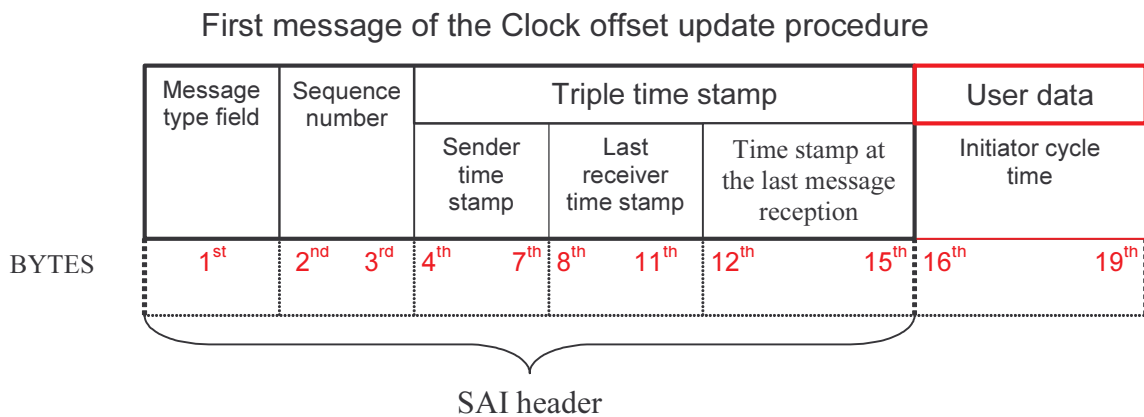

Figure 12: OffsetStart message

5.4.8.4.2 The different fields of the OffsetStart message are:

Message type field: 01 (hexa value)

Sequence number

Sender time stamp: This field defines the time stamp of the clock offset estimation initiator.

Last received time stamp: This field gives usually the last time stamp transmitted from the responder to the initiator. As there is no previous time stamp value given by the “responder, the value is set to “0”.

Time stamp at the last message reception: This field usually gives the time value at the last message reception from the responder. As there is no previous application message from the responder, this field is set to “0”.

Initiator cycle time: This field gives optionally the message transmission cycle in case of systems using cyclic transmission from the initiator to the responder. If the message transmission is non-cyclic, the value is set to “0”. The “Initiator cycle time” uses the same format and time resolution as the time stamp field.

5.4.8.4.3 The OffsetAnsw1 message structure shall be the following:

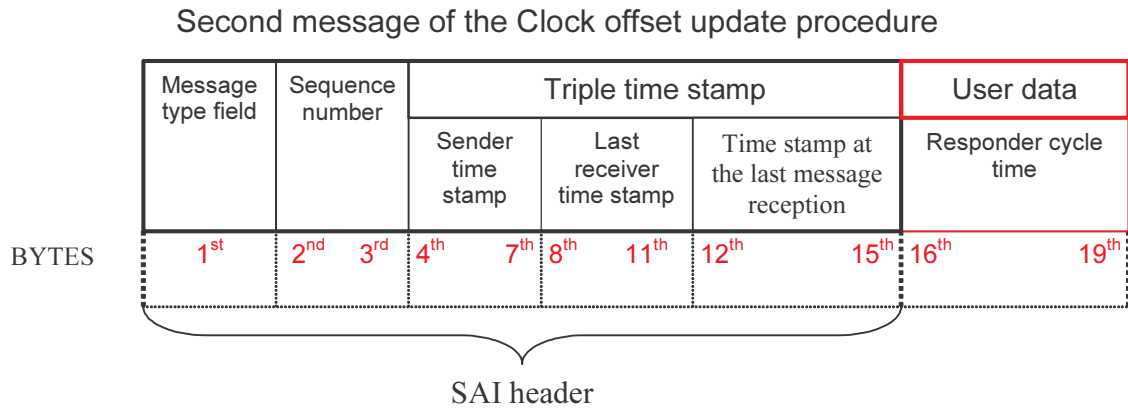

Figure 13: OffsetAnsw1 message

5.4.8.4.4 The different fields of the OffsetAnsw1 message are:

Message type field: 02 (hexa value)

Sequence number

Sender time stamp: This field defines the time stamp of the responder.

Last received time stamp: This field gives the last initiator time stamp transmitted from the initiator to the responder.

Time stamp at the last message reception: This field gives the time value at the reception by the responder of the first message of the clock offset update procedure.

Responder cycle time: This field gives optionally the message transmission cycle in case of systems using cyclic transmission from the responder to the initiator. If the message transmission is non-cyclic, the value is set to “0”. The responder cycle time uses the same format and time resolution as the time stamp field.

5.4.8.4.5 The OffsetAnsw2 message structure shall be the following:

Third message of the Clock offset update procedure

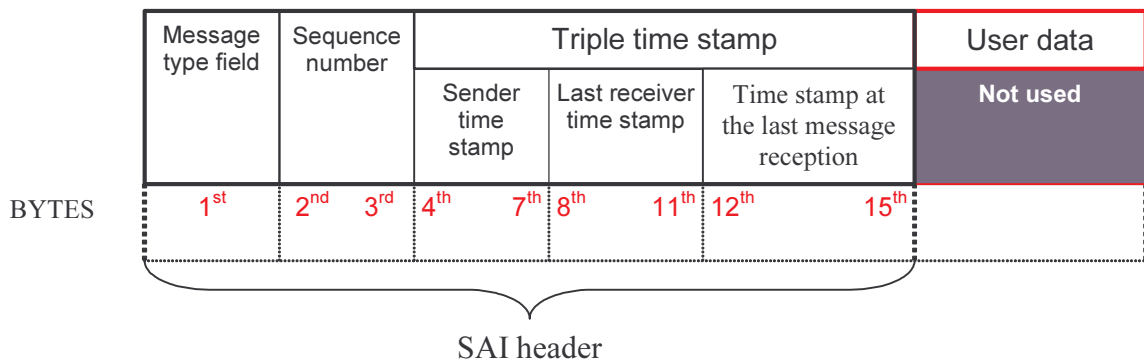

Figure 14: OffsetAnsw2 message

5.4.8.4.6 The different fields of the OffsetAnsw2 message are:

Message type field: 03 (hexa value)

Sequence number

Sender time stamp: This field defines the time stamp of the initiator.

Last received time stamp: This field gives the last time stamp transmitted from the responder to the initiator.

Local time when the last message was received: This timestamp gives the time of the last responder message reception by the initiator (reception time of the message OffsetAnsw1).

5.4.8.4.7 The OffsetEst message structure shall be the following:

Fourth message of the Clock offset update procedure

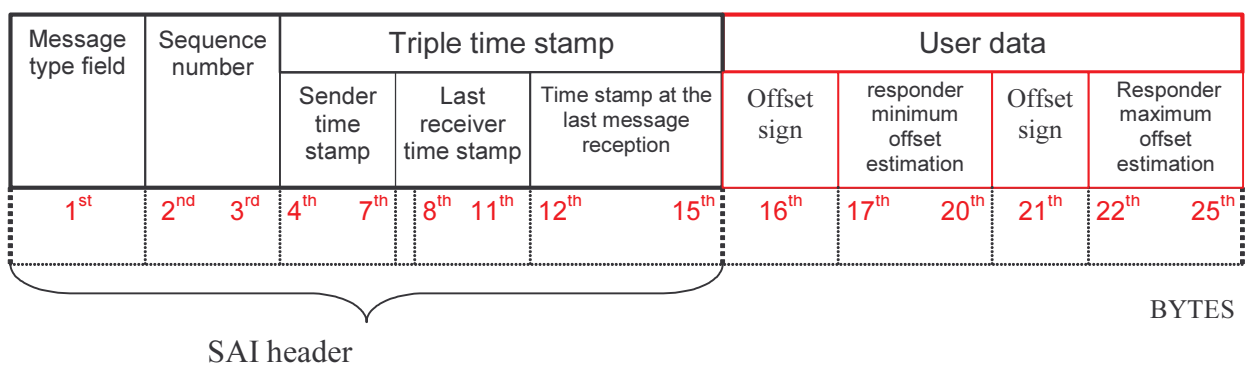

Figure 15: OffsetEst message

5.4.8.4.8 The different fields of the OffsetEst message are:

Message type field: 04 (hexa value)

Sequence number

Sender time stamp: This field defines the time stamp of the responder.

Last received time stamp: This field gives the initiator last time stamp transmitted from the initiator to the responder.

Time stamp at the last message reception: This field gives the time value at the reception by the responder of the third message of the clock offset update procedure.

Offset sign: This field gives the sign of the algebraic sign of the responder minimum offset estimation. This byte is coded using the big Endian byte representation. A value of “0” indicates a positive or null value for the offset. A value of “1” indicates a negative value for the offset.

Responder minimum offset estimation: This field gives the minimum offset estimation computed by the responder. This field uses the same format and time resolution than the time stamp fields.

Offset sign: This field gives the sign of the algebraic sign of the responder maximum offset estimation. This byte is coded using the big Endian byte representation. A value of “0” indicates a positive or null value for the offset. A value of “1” indicates a negative value for the offset.

Responder maximum offset estimation: This field gives the maximum offset estimation computed by the responder. This field uses the same format and time resolution as the time stamp field.

5.4.8.4.9 The OffsetEnd message structure shall be the following:

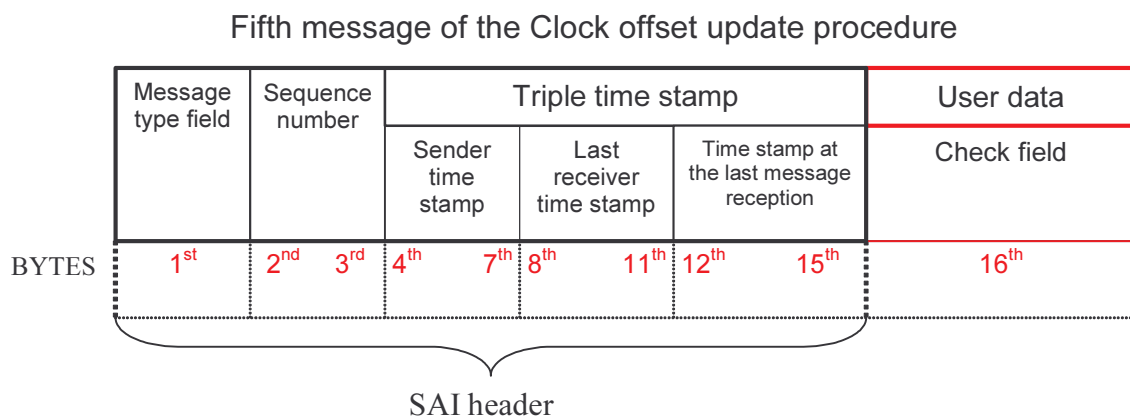

Figure 16: OffsetEnd message

5.4.8.4.10 The different fields of OffsetEnd message are:

Message type field: 05 (hexa value)

Sequence number

Sender time stamp: This field defines the time stamp of the responder.

Last received time stamp: This field gives the last responder time stamp transmitted from the responder to the initiator.

Time stamp at the last message reception: This timestamp gives the time of the last responder message reception by the initiator (reception time of the message OffsetEst).

Check field: This field gives the result of the clock offset estimation checks. If the clock offset estimation comparison is validated, the check field value is set to "1". In case of non-validation, the check field value is set to "0".

5.4.8.5 Clock offset update procedure

5.4.8.5.1 The next figure specifies the clock offset update procedure:

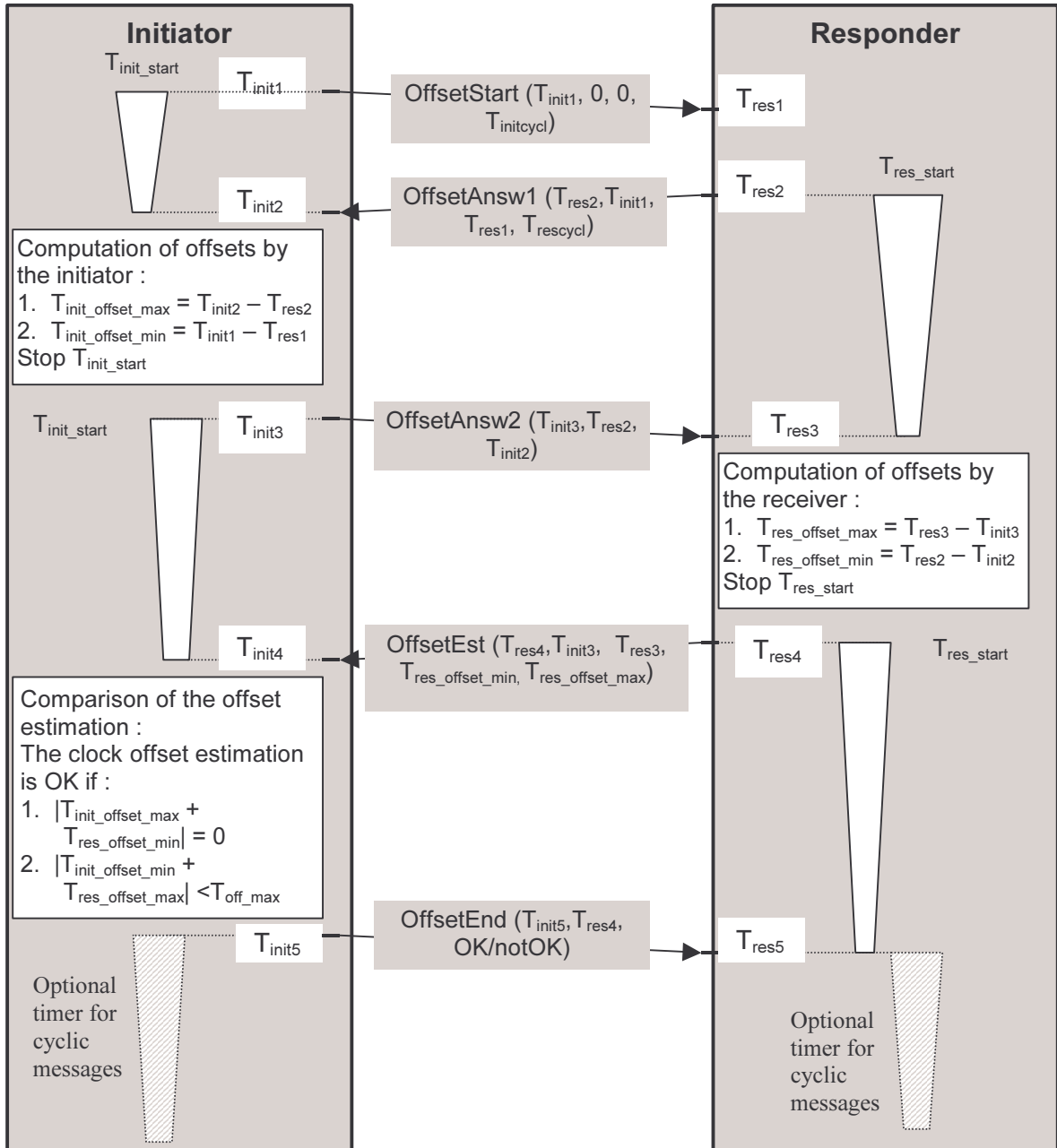

Legend :

- T_{init_start} and T_{res_start} : Initialisation timers. If the timers elapse before receiving the offset answers messages, the safe connection will be released and restarted.
- T_{initX} and T_{resX} : Xth time stamp of the initiator and the responder
- $T_{rescycl}$ and $T_{initcycl}$: Message transmission cycle of the responder and initiator. If non-cyclic transmission, the parameter is set to « 0 ».
- $T_{res_offset_max}$ and $T_{init_offset_max}$: Maximum offset estimations made by the initiator and the responder.
- $T_{res_offset_min}$ and $T_{init_offset_min}$: Minimum offset estimations made by the initiator and the responder.
- T_{off_max} : maximum difference between offset estimations.
- OK/notOK : Result of the offset estimation check.

Figure 17: Clock offset update procedure

© This document is confidential and restricted to
ALSTOM * ANSALDO SIGNAL * BOMBARDIER * INVENSYS RAIL * SIEMENS * THALES

- 5.4.8.5.2 The initiator shall begin the clock offset update procedure by sending the OffsetStart message.
- 5.4.8.5.3 The initiator starts the T_{init_start} timer at the OffsetStart message transmission. If the initiator does not receive the OffsetAnsw message at the T_{init_start} timer expiration, the error shall be managed using the error handling procedure (see §5.4.10).
- 5.4.8.5.4 At the OffsetStart message reception, the responder shall answer sending the OffsetAnsw message.
- 5.4.8.5.5 At the OffsetAnsw message transmission, the responder starts a timer: T_{res_start} . If the OffsetAnsw2 message is not received at the timer expiration, the error shall be managed using the error handling procedure (see §5.4.10).
- 5.4.8.5.6 If the initiator receives the OffsetAnsw message before the T_{init_start} expiration, the initiator shall estimate the maximum and minimum offsets between the clocks of the initiator and the responder.
- 5.4.8.5.7 Then the initiator sends the message OffsetAnsw2 to the responder. At the OffsetAnsw2 transmission, the initiator starts the T_{init_start} timer. If the initiator does not receive the OffsetEst message at the T_{init_start} timer expiration, the error shall be managed using the error handling procedure (see §5.4.10).
- 5.4.8.5.8 If the responder receives the OffsetAnsw2 message before the T_{res_start} expiration, the responder shall estimate the maximum and minimum offsets between the clocks of the initiator and the responder.
- 5.4.8.5.9 Then the responder sends the message OffsetEst to the initiator. At the OffsetEst transmission, the responder starts the T_{res_start} timer. If the responder does not catch the OffsetEnd message at the T_{res_start} timer expiration, the error shall be managed using the error handling procedure (see §5.4.10).
- 5.4.8.5.10 If the initiator catches the OffsetEst message before the expiration of the T_{init_start} timer, the initiator shall check the maximum and minimum offset estimations made respectively by the initiator and the responder. Then the initiator sends, using the Offset End message, the result of the offset check to the responder. In case of failure of the check, the error shall be managed using the error handling procedure (see §5.4.10).
- 5.4.8.5.11 At the OffsetEnd message reception, the responder shall take into account the clock offset estimation result. In case of failure of the check, the error shall be managed using the error handling procedure (see §5.4.10).
- 5.4.8.5.12 In case of the validation of the clock-offset estimations and cyclic message transmission in one or both directions, an optional TTS cyclic timer could be activated. This timer is not safety related and is used only to detect, at an early stage, missing cyclic messages.

5.4.8.5.13 The optional TTS cyclic timer is reset at each message reception. If no message is caught at the timer elapsing, the error shall be managed using the error handling procedure (see §5.4.10).

5.4.8.6 Time stamp procedure and check

5.4.8.6.1 The message used to transfer application data between application layers shall be compliant with the following figure:

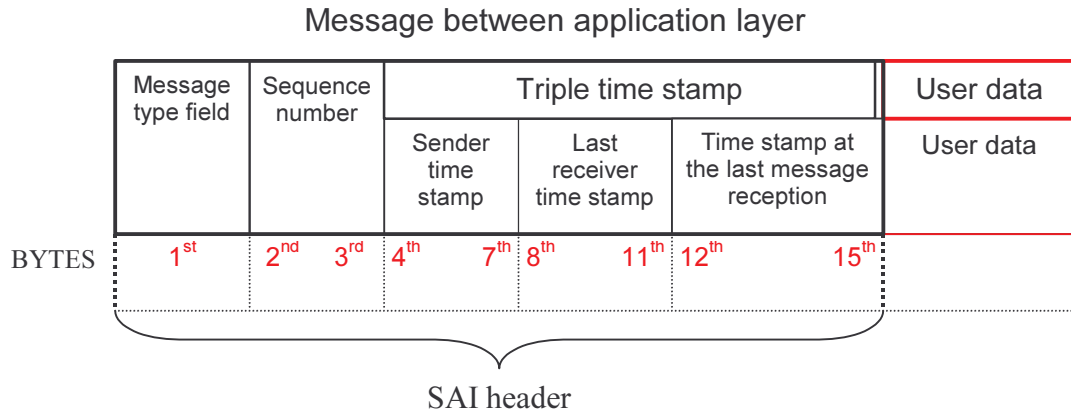

Figure 18: Application data message

5.4.8.6.2 The different type fields are:

- Message type field: 6 (hexa value)
- Sequence number
- Sender time stamp: This field defines the time stamp of the sender.
- Last received time stamp: This field gives the last time stamp transmitted from the receiver to the sender.
- Time stamp at the last message reception: This timestamp gives the time of the last message reception from the pair entity
- User data: User data field.

5.4.8.6.3 The time stamp principles consist of:

Put the sender's own time stamp in the sender time stamp field.
 Put the last time stamp received from the receiver in the last received time stamp field.
 Put the sender time stamp at the last message reception from the receiver in the Time stamp at the last message reception field.

5.4.8.6.4 It is a matter for the receiver sub-system to manage the zero crossing of the time stamp information coming from the sender.

5.4.8.6.5 The next figure illustrates the triple time stamping principle:

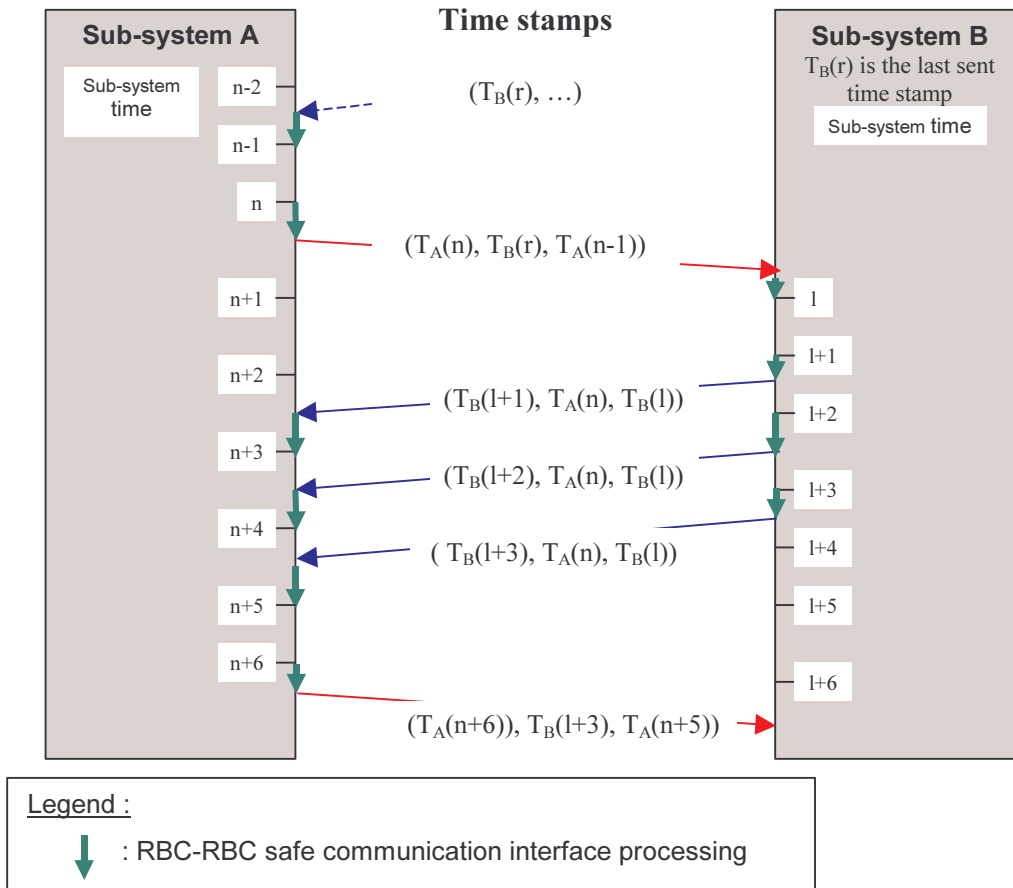

Figure 19: Triple time stamp principle

- 5.4.8.6.6 In case of a mistake in the time stamp procedure, the error shall be managed using the error handling procedure (see §5.4.10).
- 5.4.8.6.7 After the Clock offset update procedure, the maximum and minimum clock offsets are fixed and the time validity of the data application messages can be estimated.
- 5.4.8.6.8 The messages sent by the sender devices shall be time stamped using the sender clock, the last time stamp received from the peer entity and the time stamp of the reception of the last message coming from the peer entity.
- 5.4.8.6.9 When the receiver device receives the application data message, the sending time of the message shall be estimated in terms of the receiver clock, using the minimum clock offset estimation done by the receiver and the extra processing delay estimation. This estimation is given by the next expression:

$$T_{\text{receiver}} = T_{\text{time_stamp_sender}} - \Delta T_{\text{extra_delay}} + T_{\text{rec_offset_min}}$$

- 5.4.8.6.10 The difference between the sending time estimated in terms of the receiver clock and the message reception time by the receiver device ($T_{\text{rec_current}} - T_{\text{receiver}}$) allows to estimate the freshness of the message.

- 5.4.8.6.11 The delay of the message is acceptable if the difference result assures the time validity of the data transmitted. The time validity is defined by a value T_{max} . This parameter is a configuration variable agreed between the both peers. In case of non-tolerable delay, the message is rejected and the error has to be managed using the error handling procedure (see §5.4.10).
- 5.4.8.6.12 The T_{max} parameter corresponds with the maximum validity time of the data coming from the pair entity.
- 5.4.8.6.13 The T_{max} value allows detection of an increase of the transmission time and a positive temporal drift between the two device clocks.
- 5.4.8.6.14 Obviously, the difference result ($T_{rec_current} - T_{receiver}$) has to be positive. If the result is negative, the error shall be managed using the error handling procedure (see §5.4.10).
- 5.4.8.6.15 The next figure describes the time validity check procedure. The following abbreviations are used:

$T_{time_stamp_sender}$: transmission sender time stamp (sender time stamp field in the time stamp message structure).

$T_{receiver}$: estimation of the application data time transmission in terms of receiver clock.

ΔT_{extra_delay} : total sum of the extra delays due to the processing time of the application data in the sender sub-system.

$T_{rec_offset_min}$: minimum clock offset estimation done by the receiver.

T_{max} : maximum validity time.

$T_{rec_current}$: current time of the receiver at the message reception.

T_{init} : time of the application data transmission in terms of sender clock.

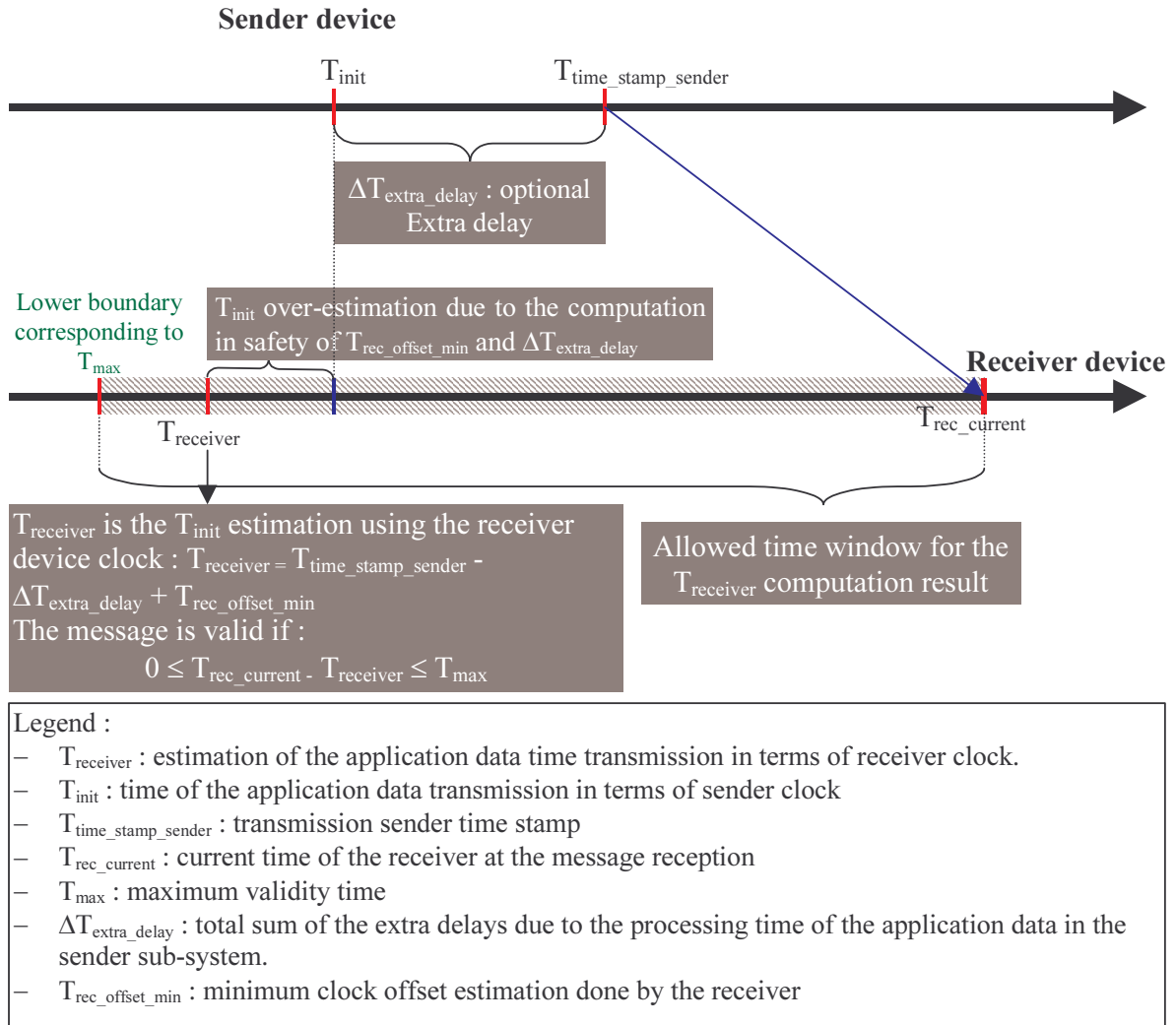

Figure 20: Time stamping computation

5.4.8.7 Clock offset update update

5.4.8.7.1 The clock offset update procedure shall be performed at least periodically according to a configured value.

5.4.8.7.2 The next figure specifies the clock offset update procedure:

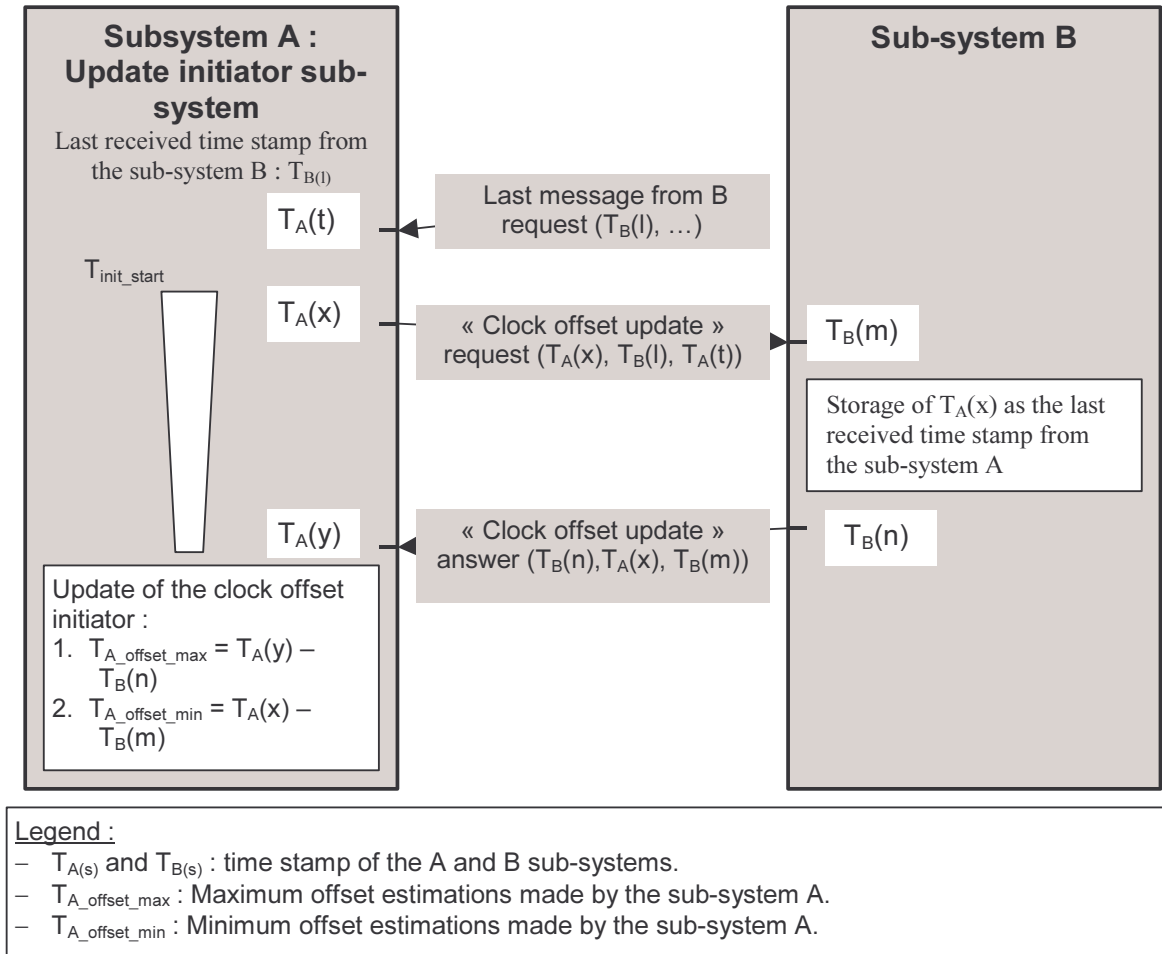

Figure 21: Clock offset update procedure

- 5.4.8.7.3 The structure of the message used for the clock-offset update shall be compliant to the structure of application data message with no user data field.
- 5.4.8.7.4 The timer T_{init_start} shall be use to supervise the time needed to perform the Clock offset update procedure.
- 5.4.8.7.5 If this time is higher than the T_{init_start} timer value, it means that the transmission delay is too high to validate the Clock offset update procedure.
- 5.4.8.7.6 In case of failure of the Clock offset update, the error has to be managed using the error handling procedure (see §5.4.10) and the update shall be repeated until successful.
- 5.4.8.7.7 At the reception of the clock offset update answer, the initiator of the procedure shall check that the clock offset update answer is related to the last clock offset update request: the last receiver time stamp field of the answer shall be equal to the sender time stamp field of the last clock offset update request.

5.4.9 EC defence technique

5.4.9.1 General overview

- 5.4.9.1.1 The EC defence technique is used to protect the application data message against the delay threat, as required by EN 50159-2, and to ensure the time validity of the application data.
- 5.4.9.1.2 The protection against the delay threat is achieved by using the EC counter contained in the Header of each message received from the peer entity.
- 5.4.9.1.3 The EC shall have a fixed period.
- 5.4.9.1.4 The detection of the delay threat is achieved by making a comparison between the EC counter contained in the message received from the peer entity and the expected EC counter in that receiver EC.
- 5.4.9.1.5 This defence technique consists in guaranteeing in transmission the availability of a message (without application data, if not required by the application) within a certain time period starting from last transmitted message, therefore turning the transmission mode into pseudo-cyclic. So at the other side of the safe connection, it is possible to manage a timeout on the data receiving.

5.4.9.2 Format of EC counter

- 5.4.9.2.1 The EC counter shall be big Endian coded on 32 bits.
- 5.4.9.2.2 The EC counter has a value from 0 to 4294967295.
- 5.4.9.2.3 For each direction, the EC counter shall be independent.
- 5.4.9.2.4 There is no requirement for EC counter initialisation. The receiver shall accept any EC counter value in the first EC counter received from the peer entity in the ExecutionCycleStart message.
- 5.4.9.2.5 If the EC counter value is different from the maximum value, the EC counter shall be incremented by one at each EC of the sender.
- 5.4.9.2.6 Once the EC counter value reaches the maximum value, the value of the sequence number at the next EC shall be set to 0.
- 5.4.9.2.7 The handling of the Sequence Number shall be independent from the handling of the EC Counter in both the sender and the receiver subsystems.

5.4.9.3 Initialisation procedure of the EC defence technique

- 5.4.9.3.1 Once the safe connection between the Euroradio SL's of the two entities has been established, two messages are exchanged between the two safe application intermediate sub-layers in order to exchange the parameters needed for the EC defence technique.

5.4.9.3.2 The following figure illustrates the initialisation procedure:

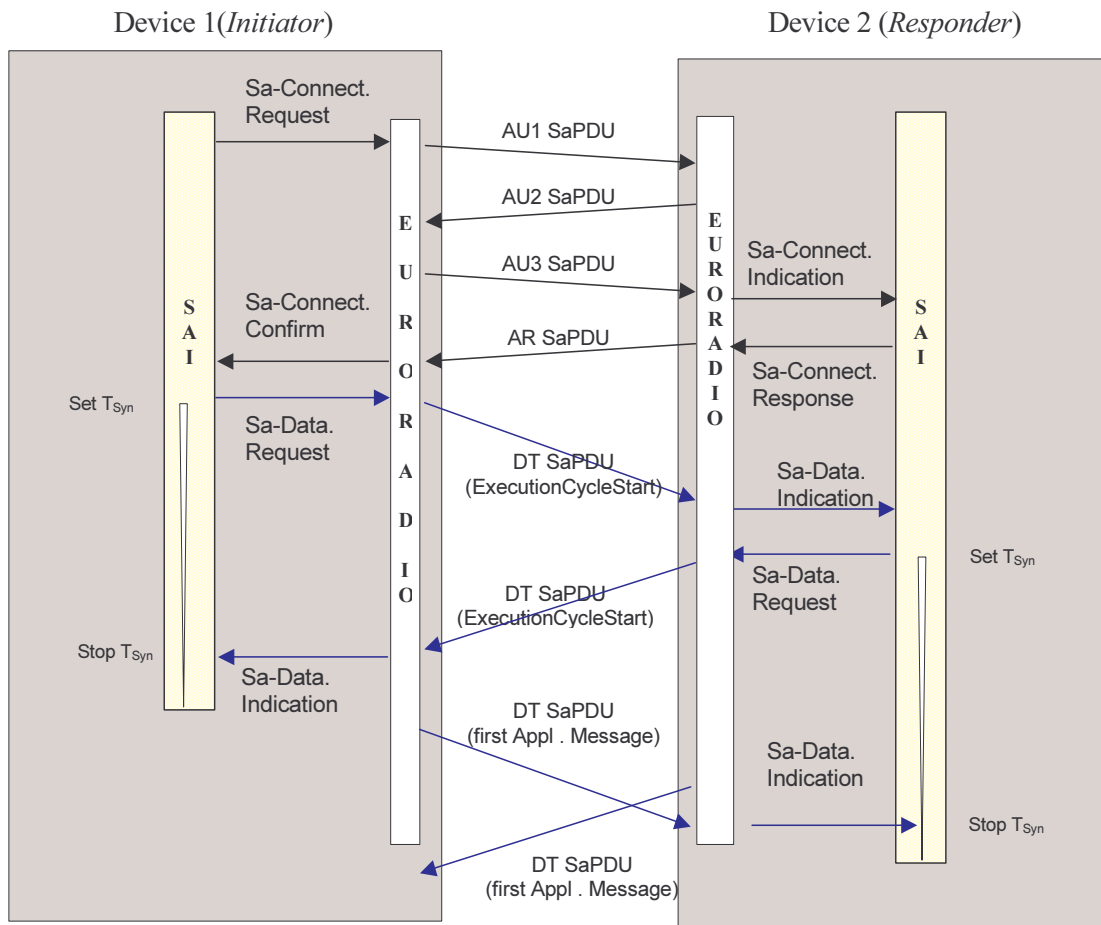

Figure 22: Initialisation phase of the EC defence technique

5.4.9.3.3 Once the safe connection has been established between the two entities using the AU1, AU2, AU3 and AR SaPDU's, the entity that initiated the safe connection shall send an ExecutionCycleStart message to the peer entity with its initial EC counter and its EC period.

5.4.9.3.4 The peer entity shall answer with an ExecutionCycleStart message containing its own information (initial EC counter and EC period).

5.4.9.3.5 After the reception of the ExecutionCycleStart from the remote, the initiator entity can start sending its Application Messages, and shall apply the EC Defence Technique. The responder entity can start sending its Application Messages on the next cycle after the forward of the ExecutionCycleStart to the initiator entity.

5.4.9.3.6 A timer (T_{Syn}) shall be implemented in each peer entity in order to detect unacceptable initial delays:

In the SAI of the connection initiator entity: the timer is set at the sending of the ExecutionCycleStart message and is stopped at the reception of the ExecutionCycleStart message from the responder;

In the SAI of the connection responder entity: the timer is set at the sending of the ExecutionCycleStart message and is stopped at the reception of the first DT SaPDU by the counterpart SAI, containing the first Application Message.

5.4.9.3.7 If a timer expires before the reception of the expected message, the error has to be managed using the error handling procedure (see 5.4.10).

5.4.9.3.8 The ExecutionCycleStart message structure shall be compliant with the following figure:

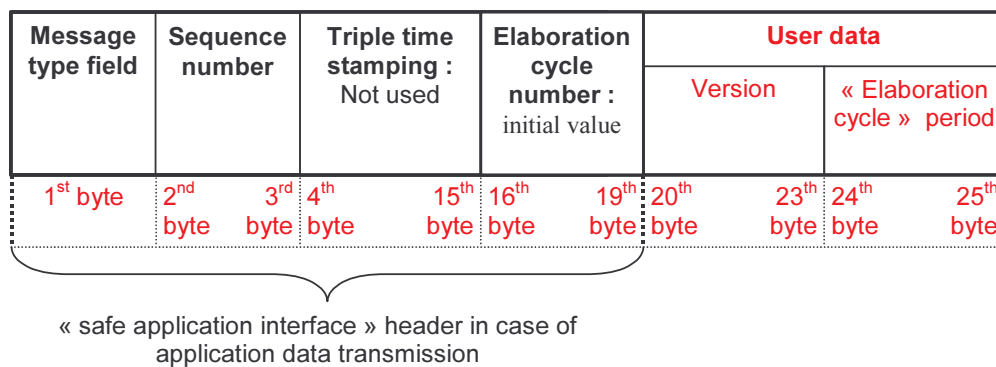

Figure 23: ExecutionCycleStart message

5.4.9.3.9 The EC period shall be coded, Big Endian, on two bytes. The EC period has a value from 0 to 65535. The least significant bit time value is equal to 1 msec (resolution is 1 msec).

5.4.9.3.10 The Version field shall be coded Big Endian on four bytes. The Version field can be used to verify the consistency of the versions of the local and remote SAI software.

5.4.9.4 EC counter check procedure

5.4.9.4.1 Once the initialisation procedure of the EC defence technique has been successfully achieved, each entity shall check if the application data transmitted by the peer entity is obsolete or not.

5.4.9.4.2 This defence technique is based on the evaluation of the value of the EC Counter contained in the messages received by the remote subsystem, which is compared with the expected one (*Ex*).

5.4.9.4.3 The first step of the EC defence technique consists in defining the expected EC Counter. For the computation of the expected EC value, the ratio *R* between the local

and the remote EC period shall be computed by each SAI entity at the end of the initialisation of the EC defence technique¹ using the following formula:

$$R = \text{receiver EC period} / \text{sender EC period.}$$

Note: R is a real number.

- 5.4.9.4.4 At each EC of the receiver, the expected EC value (Ex) to be used in the next EC shall be updated using the following formula:

$$\text{Next } Ex = (Ex \text{ value of the current cycle}) + R$$

Note: Ex is a real number².

- 5.4.9.4.5 The current state is computed at the end of each receiver EC and depends **only** on the integer variable $Delta$ which is computed using the following formula:

$Delta$ = lower integer value of (Ex - EC Counter contained in the last message received from the remote entity in that EC).

- 5.4.9.4.6 If no message arrives to the receiver in an EC, the receiver shall compute $Delta$ (and consequently the new state) using the EC counter of the last message received in the previous cycles. When more than one application messages are received in an EC, the last EC counter value received shall be used.

- 5.4.9.4.7 The state transition diagram defined by the following figure shall be applied by the SAI receiver at each EC. If $Delta$ is greater or equal to the Alarm State (e.g. 3 in the case described by the following figure), an alarm shall be issued and the error has to be managed using the error handling procedure (see §5.4.10). In the following example that means the EC counter of the last message received from the peer entity is at least 3 sender cycles older than the expected EC counter. If the $Delta$ value is greater or equal to the alarm state, all the messages received during the cycle have to be discarded.

- 5.4.9.4.8 When the initiator receives the EC Start message from the responder, the initiator shall initialise the Ex using the EC counter value contained in that message and, in the same EC, update it using the formula in §5.4.9.4.4³.

- 5.4.9.4.9 When the responder receives the first Application Data message from the initiator, the responder shall initialise the Ex using the EC counter value contained in that message received from the initiator and, in the same EC, update it using the formula in §5.4.9.4.4⁴.

¹ The ratio R can be also set and fixed as an equipment configuration parameter. The choice of dynamic or static setting of the R parameter must be fixed and agreed between the two parties before the equipment start up.

² R and Ex are real numbers, while the EC periods and EC numbers are integers.

³ If more Application Data Messages are received in this cycle after the EC Start, the EC contained in the last message is used to update the $Next Ex$

⁴ If more Application Data Messages are received in this cycle, the EC contained in the last message is used to update the $Next Ex$

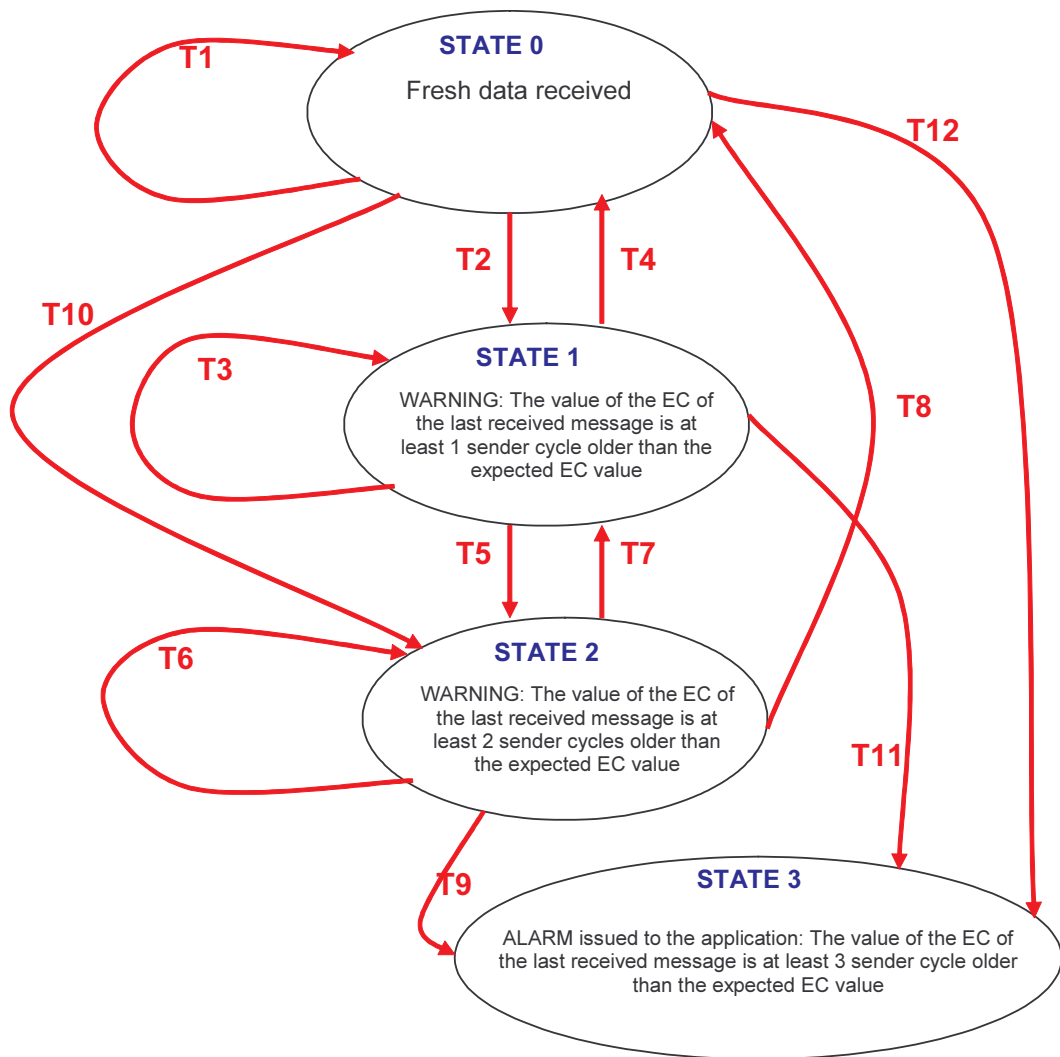

Description of transitions :

- **T1** : receiver « Execution Cycle » ended and *Delta* is lower or equal to 0.
- **T2** : receiver « Execution cycle » ended and *Delta* is equal to 1.
- **T3** : receiver « Execution cycle » ended and *Delta* is equal to 1.
- **T4** : receiver « Execution Cycle » ended and *Delta* is lower or equal to 0.
- **T5** : receiver « Execution cycle » ended and *Delta* is equal to 2.
- **T6** : receiver « Execution cycle » ended and *Delta* is equal to 2.
- **T7** : receiver « Execution cycle » ended and *Delta* is equal to 1.
- **T8** : receiver « Execution Cycle » ended and *Delta* is lower or equal to 0.
- **T9** : receiver « Execution Cycle » ended and *Delta* is greater or equal to 3.
- **T10** : receiver « Execution cycle » ended and *Delta* is equal to 2.
- **T11** : receiver « Execution Cycle » ended and *Delta* is greater or equal to 3.
- **T12** : receiver « Execution Cycle » ended and *Delta* is greater or equal to 3.

Figure 24: EC state machine

5.4.9.5 Further procedures of the EC defence technique

5.4.9.5.1 Both the effects of long term drift of the clock and the error caused by approximation of the EC cycle⁵ may result in a very slow change of the EC period (with respect to the

⁵ a permanent error of some tens of ppm is to be expected for the clock source (clock accuracy)

official value stated in the EC Start message) and so in an error of R (with respect to the value computed at the end of the initialisation phase). This can lead, in a long period, to the receiving of:

- More messages than the expected, because the sender Subsystem is faster than the expected (or the receiver Subsystem is slower: the result is the same): this results in undue staying in the “pseudo-state –1” for a long time, then in the “pseudo-state –2” and so on (all these pseudo-states are grouped in the state 0, because the data arrived are fresh). In such states the EC counter check base procedure could not promptly detect real delays.
- Less messages than the expected, even in case there is no message delay, because the sender Subsystem is slower than the expected (or the receiver Subsystem is faster: the result is the same): this results in undue staying in the state 1 of the State Machine for a long time, then in the state 2 and so on reaching the Alarm state.

5.4.9.5.2 The following action shall be applied by the SAI, in order to correct the effects described above:

If Δ is lower or equal to a (negative) value (configuration parameter) i.e. more messages are received than the expected (when an entity receives the EC start message from the peer entity, only this message is expected within the current cycle of the receiver), the expected EC counter (Ex) shall be updated using the EC Counter contained in the last message received from the peer entity:

$$\text{Next } Ex = (\text{last EC value received in the current cycle}) + R$$

If the State Machine remains in the same state (different from the state 0) for a very long period (the number of cycles being a configuration parameter), it is forced to going back to the upper state (1 => 0, 2 => 1) by decrementing the value of the expected EC counter (Ex). The Procedure for Detection of transmission delay shall be executed in this case⁶.

5.4.9.6 Procedure for Detection of transmission delay

5.4.9.6.1 Because staying in the same state for a very long time could be due to other problems in the transmission chain⁷, like slowly increasing delay, not only to approximation of R , the corrective actions defined in §5.4.9.5 could hide these real delays: a further mechanism is provided to detect them.

5.4.9.6.2 Both the initiator subsystem and the responder one that wants to detect a possible transmission delay, shall send an “Application Message with request of ACK” to the peer entity, which has exactly the same format as the normal Application Message but

⁶ this procedure can be executed immediately before or immediately after the forcing to the upper state, this choice being a local implementation matter.

⁷ by “transmission chain” it is intended in this document all the transmission equipment and network elements between the two peer safe entities.

- a different message type (0x87 instead of 0x86). Note that this is a normal Data ApPDU containing the user data to be sent to the peer entity⁸.
- 5.4.9.6.3 At the reception of the “Application Message with request of ACK”, the Subsystem shall answer to the peer entity sending in the next cycle an “Application Message with ACK” which has exactly the same format as the normal Application Message but a different message type (0x88). Note that this is a normal Data ApPDU containing the user data to be sent to the peer entity⁹.
- 5.4.9.6.4 A timer (T_{syn}) shall be implemented in the Subsystem that sends the “Application Message with request of ACK” in order to provide a further detection of unacceptable transmission delays: the timer is set at the sending of the “Application Message with request of ACK” and is stopped at the reception of the “Application Message with ACK” from the peer entity.
- 5.4.9.6.5 If the timer expires before the reception of the expected message the error has to be managed using the error handling procedure (see 5.4.10).
- 5.4.9.6.6 This delay detection procedure is equal to that used during the initialisation procedure of the EC defence technique (initial delay detection), but using the Application Message instead of the EC Start message. This procedure is described by the following figure (where one requesting entity only is shown).

⁸ The Application Message flow and processing is not affected by this mechanism.

⁹ The Application Message flow and processing is not affected by this mechanism.

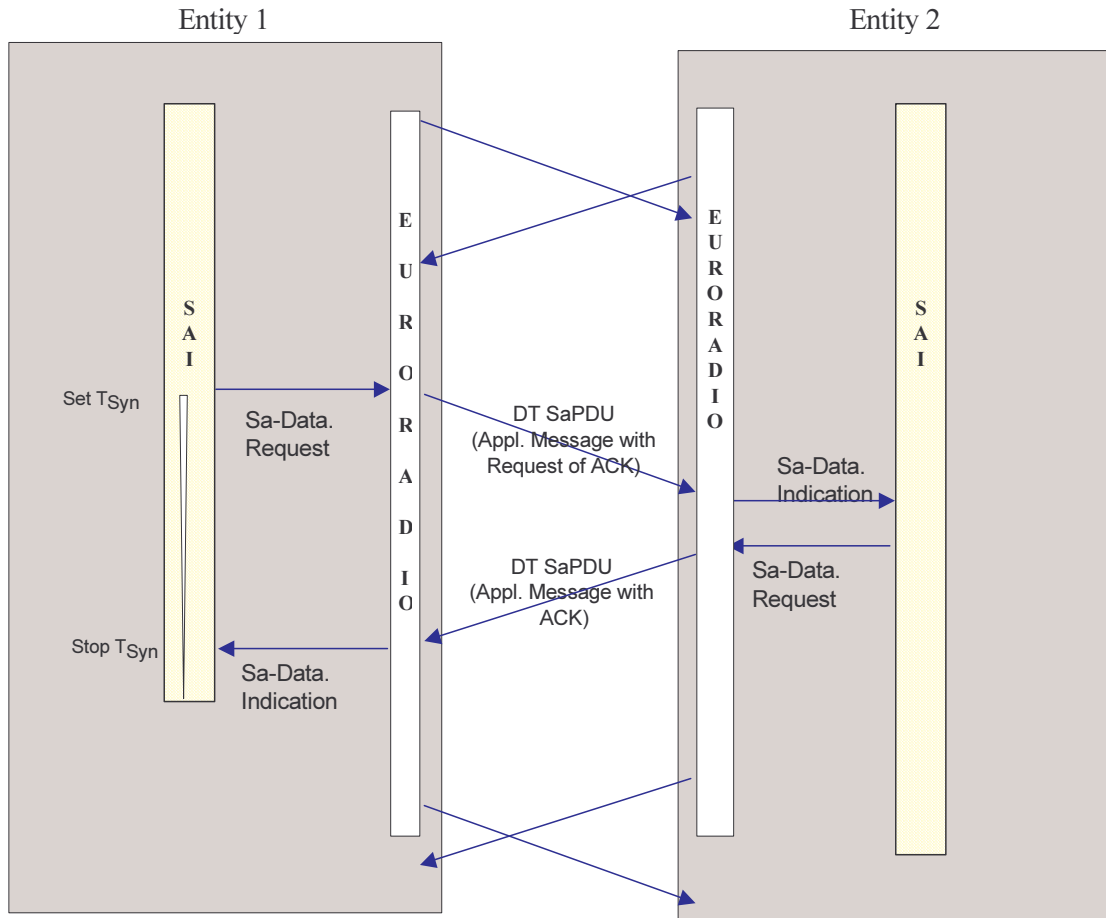

Figure 25: Procedure for detection of network delay

5.4.10 Error handling

5.4.10.1.1 The following errors are considered:

- Errors during connection establishment
- Sequencing errors
- Errors related to the optional TTS cyclic timer
- Errors related to clock offset update procedure
- Transmission delay
- Delayed messages

5.4.10.1.2 The application data contained in erroneous messages apart from sequence errors, shall be discarded (refer to §5.4.7.2).

5.4.10.1.3 All errors occurring during the SAI initial procedures (see Clock offset update procedure and Initialisation procedure of the EC defence technique) shall lead to the release of the safe connection.

- 5.4.10.1.4 For sequencing errors, errors related to the optional TTS cyclic timer, and errors related to the clock offset update procedure, transmission delay and delayed messages, the safe connection shall be released after a configurable number of successive errors (T_{succ_er}).
- 5.4.10.1.5 In case of failure of the clock offset update procedure or of the procedure for detection of transmission delay, an independent error counter shall be used and the procedure shall be repeated without delay.
- 5.4.10.1.6 In the EC technique, the connection shall be released if the *Delta* value reaches the Alarm State.
- 5.4.10.1.7 Note: The location of error handling (e.g. application, SAI, error handler) is a matter of the implementation. A notification for the error handling outside the SAI can be given.

5.5 Configuration data and rules

5.5.1 Introduction

- 5.5.1.1.1 This section provides rules for the connection establishment and informative guideline to fix SFM parameters.

5.5.2 Connection initiation rules

5.5.2.1 General overview

- 5.5.2.1.1 To establish the connection between two trackside devices, some rules have to be defined to settle precisely which device has to initiate the connection.
- 5.5.2.1.2 The co-existence of different track equipment types on the network requires a definition of priority rules for the connection initiation between the different track devices.
- 5.5.2.1.3 Each trackside equipment shall know the ETCS-ID type and ETCS-ID of each other trackside equipments to which a communication channel is established.

5.5.2.2 Connection initiation principle

- 5.5.2.2.1 Each device of the network has two tables:
- Table of passive connections
 - Table of active connections
- 5.5.2.2.2 The Table of passive connections contains the ETCS-ID list of the devices from which the device has to wait for a connection request.
- 5.5.2.2.3 Any incoming connection from remote entity which is not in the table of passive connections shall be rejected.

- 5.5.2.2.4 The Table of active connections contains the ETCS-ID list of the devices to which the device has to initiate the connection.
- 5.5.2.2.5 During the start-up procedure or after connection loss, the device begins to try to connect the other device listed in the Table of active connections.
- 5.5.2.2.6 If the connection to a device included in the Table of active connections is not established during the trackside equipment initialisation, the device shall try to connect periodically to the peer equipment.
- 5.5.2.2.7 The usual rule is to define the tables of passive and active connections in such way that the connection is initiated by the device switched on last.

5.5.3 Guideline for TTS parameter definition

5.5.3.1 T_{max} value

- 5.5.3.1.1 The T_{max} value is a system parameter, it is the maximum validity time of the application data transferred between the two RBCs.
- 5.5.3.1.2 This parameter could depend for example on the following factors:
 - Track layout
 - Performance requirements
 - RBC implementation
 - System rules

5.5.3.2 ΔT_{extra_delay}

- 5.5.3.2.1 The ΔT_{extra_delay} parameter could be used to take into account the time between the generation of the application data and the time stamping of the message at the SAI level.
- 5.5.3.2.2 The default value of this parameter is "0".

5.5.3.3 T_{init_start} and T_{res_start}

- 5.5.3.3.1 The value of these timers should be equal to the maximum time allowed to have an answer to a request.
- 5.5.3.3.2 A way to fix the timer value is to use the following rule (margin expressed in %):
 Time value = $(1 + \text{margin}/100) * (2 * \text{maximum transmission time} + \text{maximum time between request reading by the RBC and answer transmission})$

Note: The transmission time should take into account:

- the maximum network transmission time
- the time between the time stamping of the message and the sending of this one on the network

- the time requested by the receiver to read the message

5.5.3.4 T_{off_max}

5.5.3.4.1 The value of this timer should be equal to the maximum acceptable transmission time between the two devices.

Note: The transmission time should take into account:

- the maximum network transmission time
- the time between the time stamping of the message and the sending of this one on the network
- the time requested by the receiver to read the message

5.5.3.5 Optional TTS cyclic timer

5.5.3.5.1 The value of optional timer for cyclic message could be estimated using the following rule:

$$\text{Optional TTS cyclic timer} = \text{cycle of the peer RBC} + \text{maximum allowed transmission time}$$

Note: The transmission time should take into account:

- the maximum network transmission time;
- the time between the time stamping of the message and the sending of this one on the network;
- the time requested by the receiver to read the message.

5.5.3.6 Cycle for clock offset update

5.5.3.6.1 The clock offset update is used to prevent natural clock drift.

5.5.3.6.2 For each a time accuracy parameter is provided: let $Pr\%$.

5.5.3.6.3 For a system, the maximum tolerance on the clock drift could be defined: let X sec.

5.5.3.6.4 The cycle for clock offset update could be computed using the following formula (with a margin of $Y\%$):

$$\text{Cycle (sec)} = (100 * X \text{ sec} / Pr) / (1 + Y/100)$$

5.5.3.6.5 For example: $Pr = 0,1$, $Y = 100\%$ and $X = 0,5$ sec \Rightarrow Cycle = 250 sec

5.5.4 Guideline for EC parameter definition

5.5.4.1 T_{syn}

5.5.4.1.1 The value of this timer should be equal to the maximum time allowed to have an answer to a request.

5.5.4.1.2 A way to fix the timer value is to use the following rule (margin expressed in %):

Time value = $(1 + \text{margin}/100) * (2 * \text{maximum transmission time} + \text{maximum time between request reading by the RBC and answer transmission})$

Note: The transmission time should take into account:

- the maximum network transmission time;
- the time between the time stamping of the message and the sending of this one on the network;
- the time requested by the receiver to read and process the message and produce the required answer.

5.5.4.2 Alarm state

5.5.4.2.1 The “Alarm State” value is a system parameter. This parameter scales the maximum validity time of the application data transferred between the two RBCs.

5.5.4.2.2 This parameter could depend for example on the following factors:

- Track layout;
- Performance requirements;
- RBC implementation;
- System rules.

5.5.4.3 Version

5.5.4.3.1 Only one version value is presently defined: 01 (hexadecimal).

5.5.4.4 Procedure for Detection of transmission delay

5.5.4.4.1 The procedure for detection of transmission delay should be repeated cyclically.

5.5.4.4.2 The cycle should be fixed using an approach similar to the one used for the definition of the optional TTS cyclic timer.

5.5.5 Guideline for error handling

5.5.5.1 Parameter N

5.5.5.1.1 If no missing messages are allowed then N should be set to 1.

5.5.5.1.2 N has to be agreed for a specific project and for each connection.

5.5.5.1.3 If RBC's with different N are to be connected together the more restrictive value for N should be used for this connection in both RBC's.

5.5.5.2 Parameter T_{succ_er}

5.5.5.2.1 If class D is used in the ALE layer and is implemented on at least two independent physical links, the application data are sent twice using independent routes to the peer SAI. As in this case an error at the SAI level results from a major disturbance on the

two physical links, a release of the connection at the first error is recommended: $T_{succ_er} = 1$.

5.5.5.2.2 In the other configurations (class A and class D on one physical link), the application data are exchanged between the two entities on only one physical link. As in this case a single disturbance on this link could lead to an error in the receiving SAI, a release of the connection after two successive errors is recommended: $T_{succ_er} = 2$. If a highly-available network is used, the value of T_{succ_er} value could be set to "1"

5.6 TTS examples

5.6.1.1.1 The following figures illustrate the TTS technique:

All the value are expressed using the timestamp format (multiple of 10 msec).
 Tolerance windows for the transition time : between 0 and 50
 Real offset between clocks : 850 (8,5 sec). When the clock of A is equal to 850, the clock of B is equal to 0.
 Cycle of A = 50 => time to take into account incoming message and produce answer is between 50 and 100.
 Cycle of B = 30 => time to take into account incoming message and produce answer is between 30 and 60.

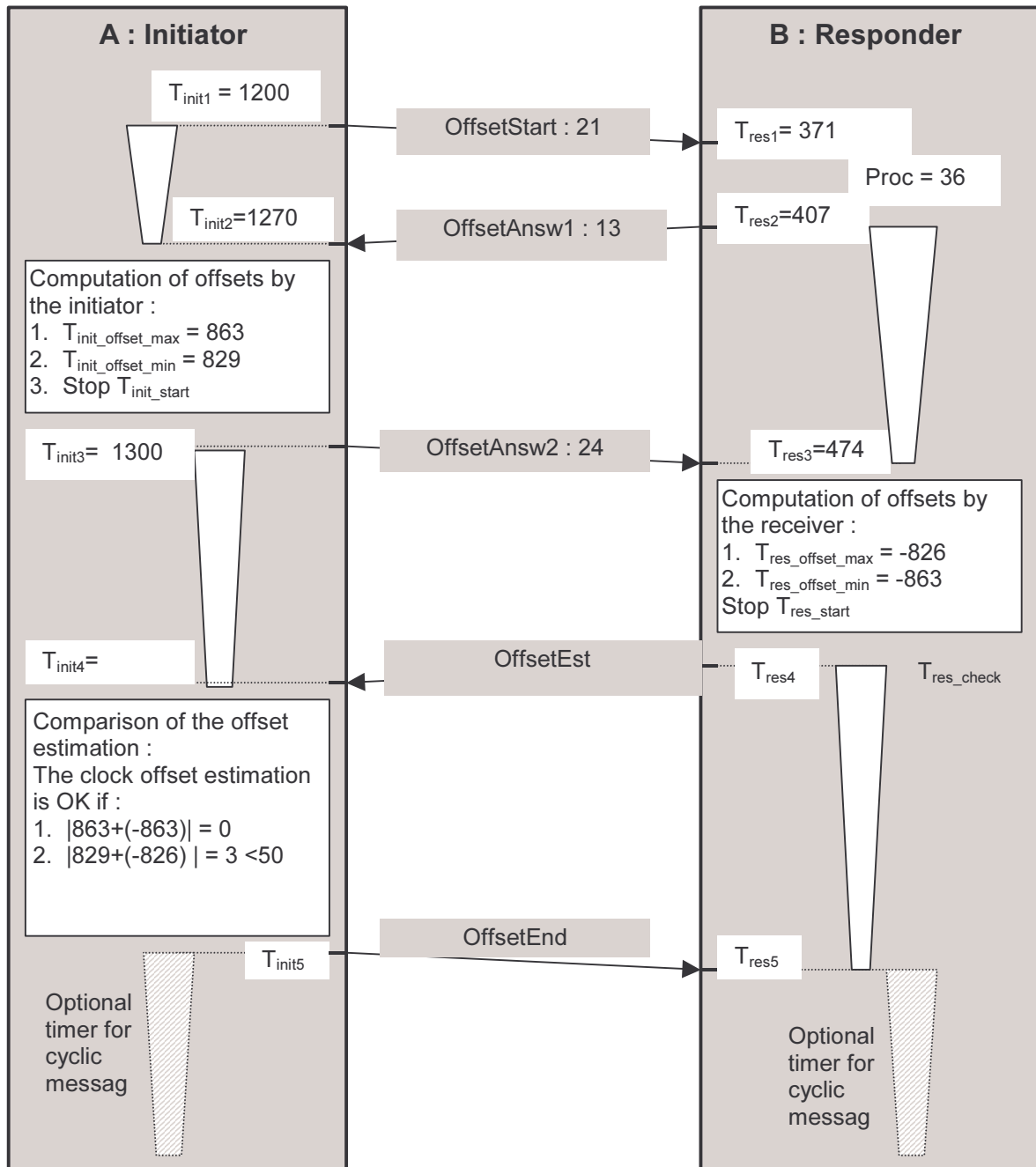
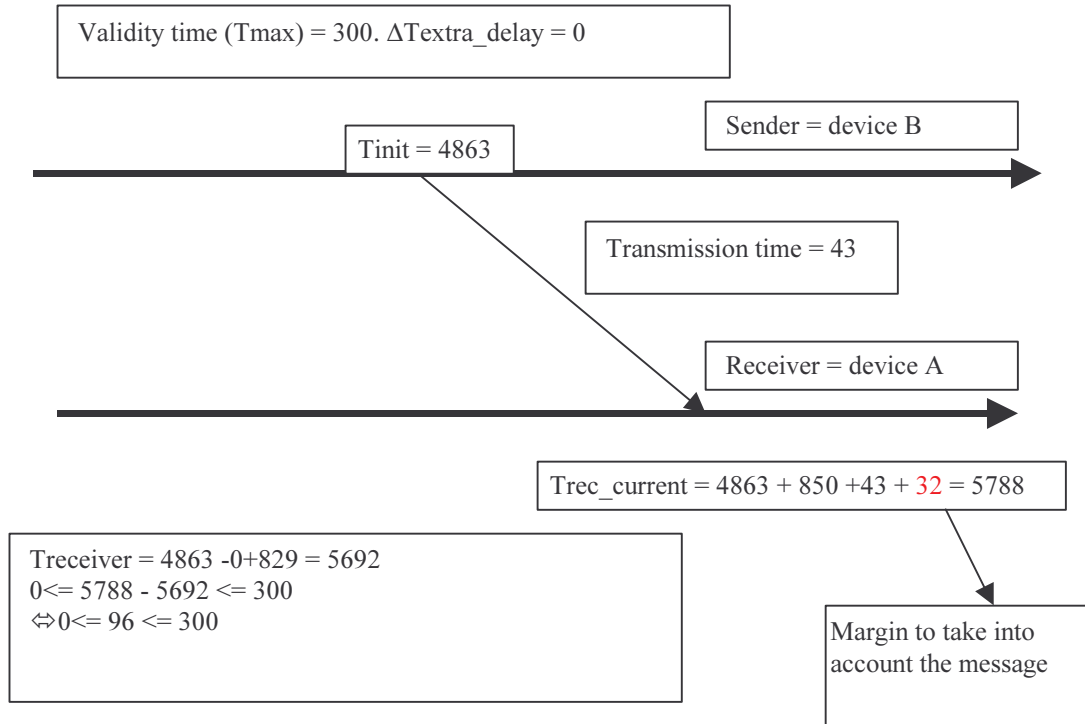

Figure 26: Example of Clock offset update procedure

FOR DEVICE A as receiver :



FOR DEVICE B as receiver :

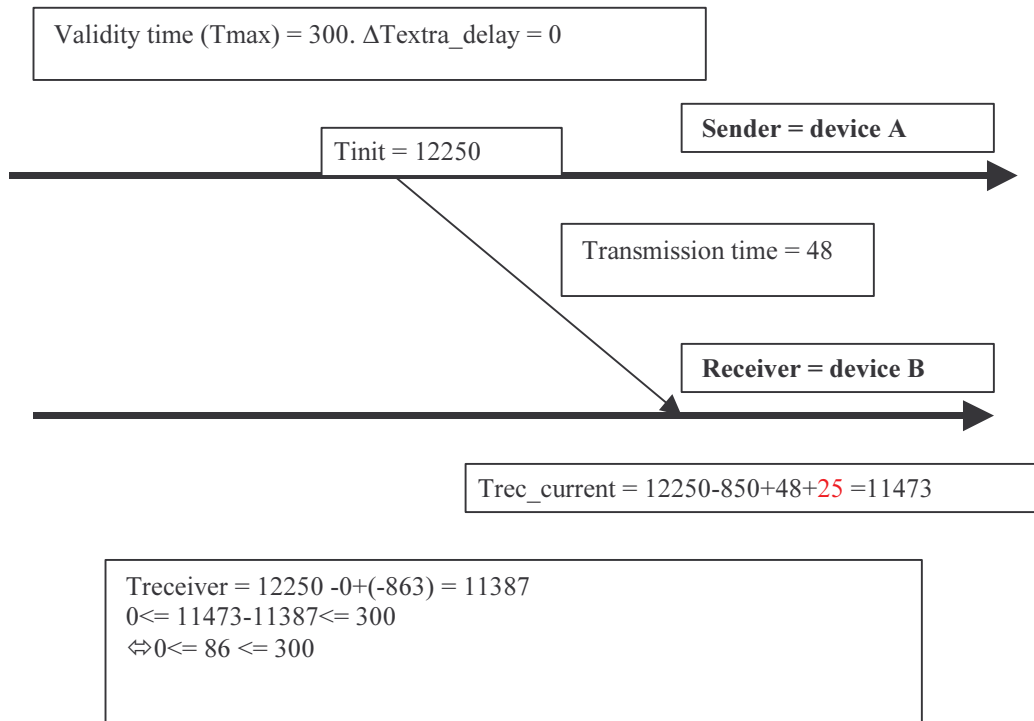

Figure 27: Example of Time stamp procedure and check

6. COMMUNICATION FUNCTIONAL MODULE

6.1 General

6.1.1.1.1 This part of the present document specifies the communication protocols used by the CFM in the RBC-RBC Safe Communication Interface.

6.1.1.1.2 This part of the specification does not define:

- the content and structure of information messages which are exchanged between components of an implementation;
- any implementation details concerning the interface itself;
- the open networks used;
- the physical architecture of the CFM.

6.1.1.1.3 This section describes only the functional interface requirements to be respected to ensure interworking at the level of the transport and network protocols. It must not be understood as a proposal to implement a particular software architecture.

6.2 Overview

6.2.1 General description

6.2.1.1.1 In this specification of the CFM both end systems are assumed fixed (i.e. not mobile), it is assumed that they can be attached to industry standard high-speed networks. This specification defines the use of Euroradio Transport Layer primitives to access redundant services running over TCP. It provides a method of communicating between ERTMS equipment using international standards and without the need for manufacturers to know the proprietary details of each other's system.

6.2.1.1.2 The general features of the CFM are as follows:

- Reliable full-duplex transfer of railway application messages;
- Transparent transfer of user data. The content, format or coding of the information is not to be restricted. Interpretation of the data structure or its meaning is not needed to achieve data transfer;
- No constraints on user data, that is the protocol shall in no way constrain the type of data to be transferred;
- Efficient data transfer, the CFM shall support well defined performance requirements including the transfer of large quantities of data at high speeds and with low latency;
- Open to different known and currently unknown applications.
- Support of physical link redundancy for availability purposes

6.3 Functional Characteristics

6.3.1 TCP equivalence to Transport Class 2 service and protocol

- 6.3.1.1.1 This specification is targeted at applications running on ground based systems operated by different suppliers. It is therefore required that these services are provided by taking advantage of industry standard TCP/IP solutions rather than the alternative protocols offered by OSI or CENELEC standards. Hence in this specification TCP is adopted to provide a reliable connection orientated service instead of ISO TP2. Any known limitations that this approach imposes are described in this document.
- 6.3.1.1.2 The aim of mandating these requirements is to ensure that flexible, high availability, high-speed and cost effective COTS solutions can be used to link the end systems so reducing cost and lead times.
- 6.3.1.1.3 The mapping between the Transport Class 2 service and TCP shall be as described in this specification, using the Adaptation Layer Entity (ALE). This entity shall transfer data between peers in discrete variable length packets named ALE packets (ALEPKTs).
- 6.3.1.1.4 The following diagram outlines the protocol stacks used to connect an ERTMS application to its counterpart (in this example via intermediate wide area network routed links).

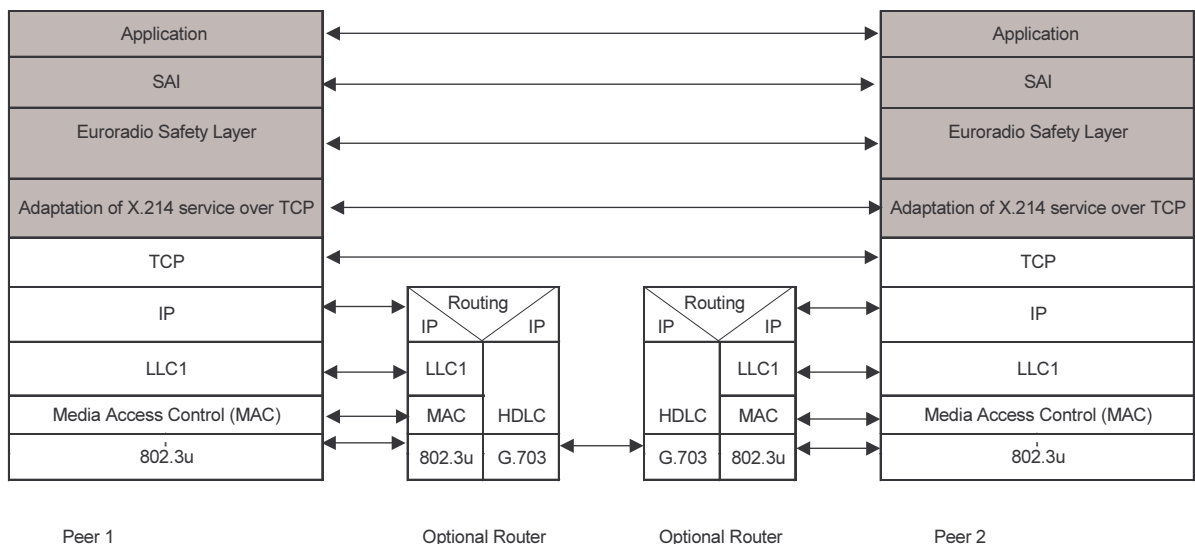

Figure 28: Protocol stacks used to connect an ERTMS application to its counterpart

Note: the shaded areas imply bespoke software, the white areas contain an example of a possible implementation

6.3.1.1.5 The diagram shows the relationship of the various components to one another. The applications responsible for providing the functionality required shall make use of the standard Euroradio Safety Protocol primitives. The Safety Protocol will access the communications sub-layers via a functional interface relevant to the environment. This will access an emulation of the ISO transport service using the standard primitives.

6.3.1.1.6 This service will actually be provided using TCP/IP as the underlying transport and network layers rather than using the ISO TP2 and T.70 that are defined in Euroradio protocols for communication between RBCs and OBUs.

6.3.1.1.7 The example diagram above shows typical IP routers being used to interconnect systems over a wide area link.

6.3.2 Class of Service

6.3.2.1.1 In order to be generically applicable there must be options to vary the quality of service requested and offered by peers. To increase availability of the service defined in this document there are a number of ways in which independently routed TCP connections may be used to support a single logical connection between peer applications (whether safe or non-safe).

6.3.2.1.2 A set of different qualities of service, known to the ALE as 'Class of Service' are specified. These are characterised as follows:

- Class A – Two links are normally used. Either of two links can be used to transfer data. All ALEPKTs are transmitted on one link only. (Typically both links shall have equal performance)
- Class D – Two links are normally used with all ALEPKTs transmitted on both links.

6.3.2.1.3 The implementation of Class D is mandatory, while the implementation of Class A is optional.

6.3.2.1.4 Implementations with one physical link are supported by the protocols.

6.3.2.1.5 Both Class A and D can operate with one single physical link only, without any impact on the safety.

6.3.2.1.6 The Class of Service used at each end of a connection shall be the same.

6.3.3 Class A request

6.3.3.1.1 A request for a Class A quality of service shall result in the Adaptation Layer attempting to make two TCP connections to the remote Adaptation Layer entity. The nominated primary connection shall be that which is used initially to transfer data. The secondary connection shall be opened, maintained and monitored by the Adaptation Layer entity but shall not be used to transfer data unless the primary route is deemed to have failed. The exact details of how these links shall be monitored and managed are contained in §6.6.

6.3.3.1.2 The definition of TCP/IP address details are contained within the Adaptation Layer and are selected based on the ETCS-ids and Application Type details that are contained in the primitive **T-Connect.Request**.

6.3.4 Class D request

6.3.4.1.1 A request for a Class D quality of service shall result in the Adaptation Layer attempting to make two TCP connections to the remote Adaptation Layer entity. Both connections shall be used to transfer all data and control messages. The safe connection shall continue to operate on one link in the event of a failure of the other. The exact details of how these links shall be monitored and managed are contained in §6.6.

6.3.4.1.2 A request for class D connection can be also accepted for one TCP connection over one physical link.

6.3.4.1.3 The definition of TCP/IP address details are contained within the Adaptation Layer and are selected based on the ETCS-ids and Application Type details that are contained in the primitive **T-Connect.Request**.

6.3.5 Relationship between TS-User and TCP

6.3.5.1.1 The diagram in Figure 29 shows the relationship between a TS-User and two TCP channels.

6.3.5.1.2 A Safe Application may use the equivalent access primitives (at the ApSAP) to access the Safe Application Intermediate Sub-layer. These are the same primitives that the Euroradio Safety Layer supports (at the SASAP) .

6.3.5.1.3 The Euroradio Safety Layer completes message protection and transmits the message to the CFM in Safety Protocol Data Units (SaPDUs) through service access primitives at TSAPs providing an ISO Transport service.

6.3.5.1.4 Some mapping of functions is required in the Adaptation Layer in order to permit the use of TCP protocol instead of an ISO Transport Class 2 protocol.

6.3.5.1.5 In order to satisfy all availability requirements, one or more TCP links are managed for each logical safe connection.

6.3.5.1.6 Finally, a standard protocol stack is used to interface LANs or WANs using TCP/IP protocols.

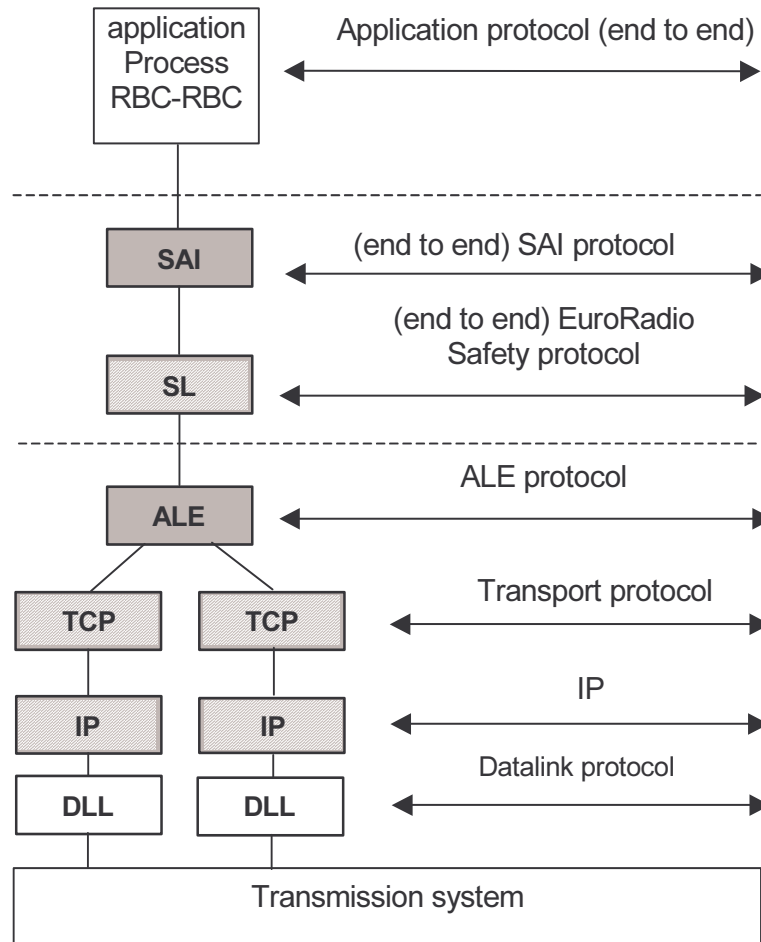

Figure 29: Relationship between a TS-User and two TCP channels

6.3.5.1.7 The next figure identifies, for each layer of the architecture, all Service Users and Service Providers, as well as the Protocol Data Unit (PDU) structure for each protocol layer:

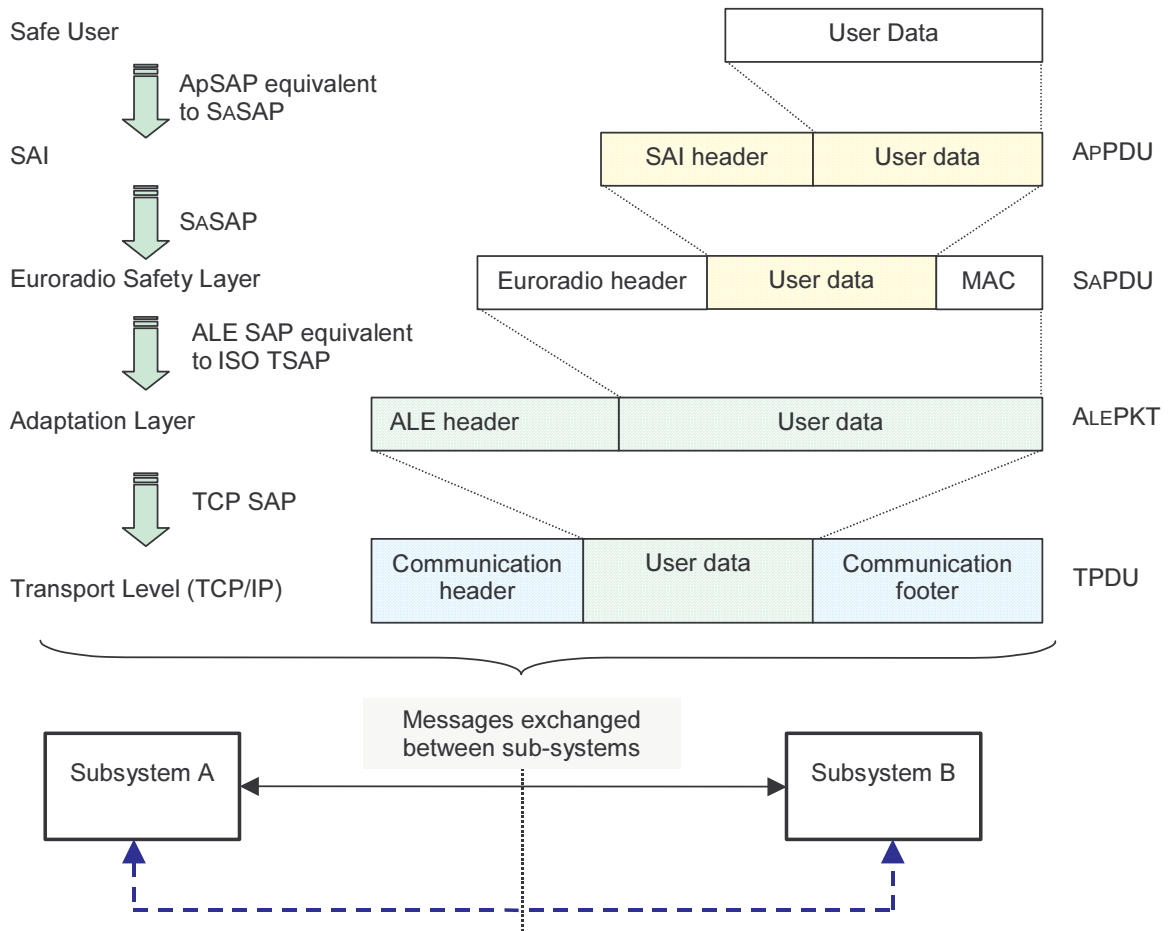

Figure 30: Reference message structure

6.3.6 Transport Priorities

6.3.6.1.1 In Subset-037, Transport priorities are related to Application type as follows:

- 0 = Not used
- 1 = ATP.

6.3.6.1.2 Transport priorities are not available nor supported over TCP.

6.4 Transport Layer Emulation using an Adaptation Layer Entity

6.4.1 General Overview

6.4.1.1.1 This section contains the functional requirements of the transport service provided by the CFM module.

6.4.1.1.2 The CFM provides TS-Users with an interface corresponding to that of the Transport Class 2 service but which achieves the functionality of ISO Transport through the use of the TCP/IP protocol.

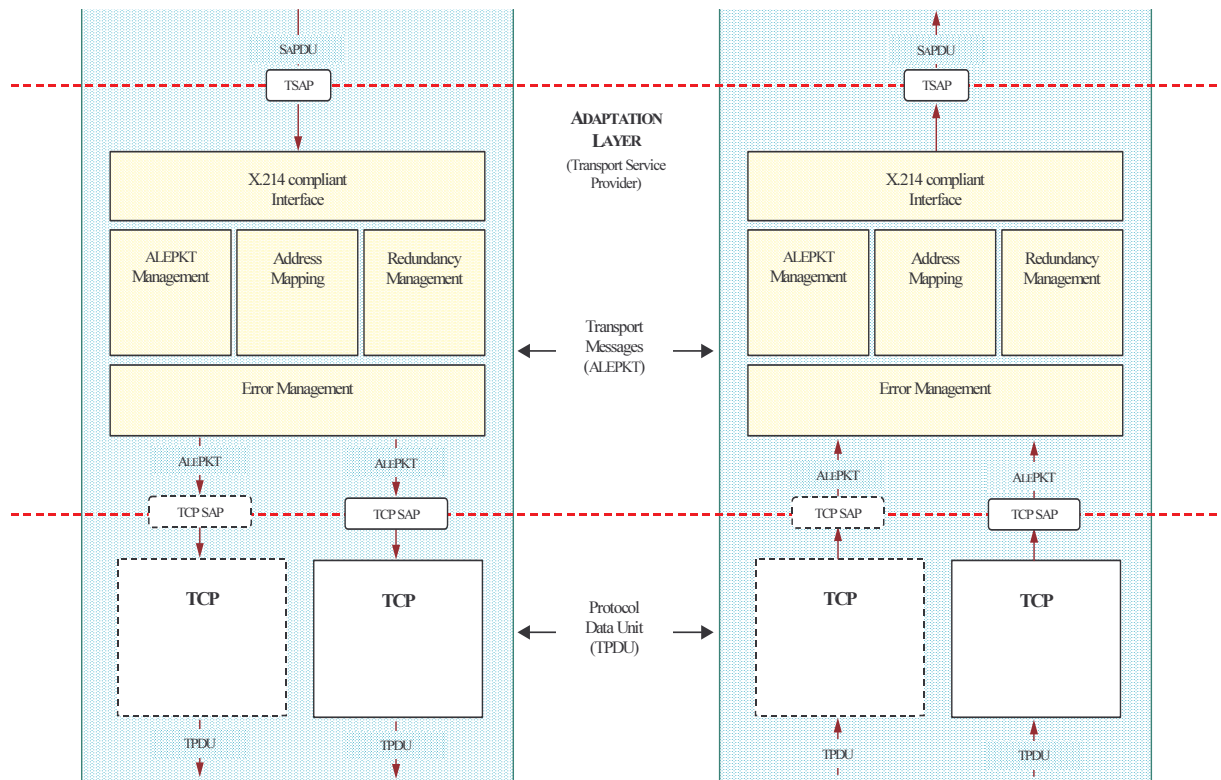

Figure 31: Example of Communication Functional Module

6.4.1.1.3 The CFM functions are detailed in the following order:

- service access primitives as defined in TSAP (Transport SAP);
- how the Adaptation Layer shall realise the correspondence between the Transport Protocol Class 2 (X.214) service and the primitives of TCP/IP protocol;
- the format of ALEPKT.
- the modes in which the same Adaptation Layer shall have to manage the redundancy of the TCP connections to be created and the realisation of the corresponding functional requirements;
- the management of errors and failures.

6.4.2 Interface Service Definition

6.4.2.1 Use of ISO Transport Service primitives

6.4.2.1.1 This section describes, at functional level, the Transport Service offered by the Adaptation Layer Entity to the TS-User.

6.4.2.1.2 NOTE: It is a matter of implementation to adapt this TS user interface to implementation needs and constraints, provided interworking between end systems and the behaviour of the system are not affected.

6.4.2.1.3 Information is transferred to and from the TS-User via the ALE Transport Service Access Point (TSAP) using the primitives listed below:

ACTIONS	DESCRIPTION
T-Connect.Request (Address Type Network Address Called ETCS-ID Calling ETCS-ID Application Type QoS User Data)	A TS-User (initiator) indicates that it wants to establish a transport connection.
T-CONNECT.RESPONSE (TCEPIDA Responding ETCS-ID User Data)	A TS-User (responder) indicates that it shall honour the request of connection establishment.
T-DISCONNECT.REQUEST (TCEPIDXMT User Data)	A TS-User indicates that the transport connection is to be closed.
T-DATA.REQUEST (TCEPIDXMT User Data)	A TS-User sends data.
EVENTS	DESCRIPTION
T-CONNECT.INDICATION (TCEPIDA Network Address Calling ETCS-ID Application Type QoS User Data)	A TS-User (responder) is notified that a transport connection establishment is in progress.
T-CONNECT.CONFIRMATION (TCEPIDB Responding ETCS-ID User Data)	A TS-User (initiator) is notified that the transport connection has been established.
T-DISCONNECT.INDICATION (TCEPIDRCV Reason User Data)	A TS-User is notified that the transport connection is closed.
T-DATA.INDICATION (TCEPIDRCV)	A TS-User is notified that data can be read from the transport connection.

User Data)	
------------	--

Table 4: Service primitives in TSAP

- 6.4.2.1.4 The use of these Transport Service primitives [X.214] shall be supported with the following modifications:
- The Mobile Network ID parameter is meaningless in this context, it shall not be used.
 - Expedited Data is not present and shall be not supported by this interface.
 - Transport Quality of Service parameters (re-defined as Class of Service) are supported.
 - Access to Non-disruptive Transport Disconnection shall be provided
- 6.4.2.1.5 Parameter values used in the X.214 service are compliant with the FIS [Subset-037], with the following extensions.
- 6.4.2.1.6 **TCEPID:** (Transport Connection End Point Identifier) is provided locally to distinguish between different transport connections. This shall have a mapping to a local TCP port id. Normally this shall be the TCP **Local_Connection_Name**
- 6.4.2.1.7 **ETCS Address Type:** qualifies the usage of sub-parameters of called address.
- 6.4.2.1.8 **Network Address:** If provided, identifies the 32-bit destination IP network address and the 16-bit destination TCP port number of the called user.
- 6.4.2.1.9 When the Network Address is supplied by the Safety Layer Entity it shall be used. Otherwise the other parameters provided shall be used by the Adaptation Layer entity to retrieve the relevant IP port and TCP address information and hence to establish a connection to the relevant remote entity.
- 6.4.2.1.10 **Called ETCS-ID:** identifies (together with the application type) the called Transport Service user.
- 6.4.2.1.11 **Calling ETCS-ID:** identifies (together with the application type) the Transport connection initiator.
- 6.4.2.1.12 **Application Type:** As detailed in Subset-037, the first 5 bits of the Application Type field specify the main application type. The minor Application Type (3 bits) specifies the main application types in more detail.
- 6.4.2.1.13 **Responding ETCS-ID:** identifies (together with the application type) the accepting/responding Transport Service user that was locally selected by the responding transport entity.
- 6.4.2.1.14 **Class of Service:** is associated with a set of parameter values. The Class of Service parameters shall not be negotiated. The requested Class of Service parameter values have to be accepted by the service provider and the peer application. Otherwise the

connection establishment has to be rejected. The Class of Service is independent of the application type.

6.4.2.1.15 **User Data:** contains the SaPDUs as required by the Euroradio FIS.

6.4.2.1.16 The tables that follow describe how the primitives can be mapped by the Adaptation Layer.

6.4.3 Mapping of X.214 primitives to TCP

6.4.3.1.1 Note: This section is for information only. Implementations of TCP which use different primitives are permissible, provided that there is no impact on interworking.

6.4.3.1.2 The tables that follow summarise how the ISO Transport Class 2 primitives (actions/events) can be mapped by the Adaptation Layer to TCP/IP protocol:

<i>Actions X.214</i>	<i>Primitives TCP</i>	<i>ALE packet type sent</i>
T-Connect.Request	TCP_OPEN_PORT TCP_SEND_DATA (AU1 ALEPKT) or TCP_ACTIVE_OPEN_WITH_DATA (AU1 ALEPKT)	1
T-Connect.Response	TCP_SEND_DATA (AU2 ALEPKT)	2
T-Disconnect.Request	TCP_Send_Data (DI ALEPKT) (wait) TCP_Close	4
T-Data.Request	TCP_Send_Data (DT ALEPKT)	3
(none)	TCP_Read_Data	
(none)	TCP_Listen_On_Port	
(none)	TCP_STATUS	
(none)	TCP_Abort	

<i>Events X.214</i>	<i>Primitives TCP</i>	<i>ALE packet type received</i>
T-Connect.Indication	TCP_Connected TCP_Data_Ready TCP_Read_Data (AU1 ALEPKT)	1
T-Connect.Confirmation	TCP_Connected TCP_Data_Ready TCP_Read_Data (AU2 ALEPKT)	2
T-Disconnect.Indication	(after a rejected TCP_Open_Port) TCP_Connect_Fails	4
	(after a TCP_Abort) TCP_Errored	
	TCP_Data_Ready TCP_Read_Data (DI ALEPKT) TCP_Close TCP_Closed	
T-Data.Indication	TCP_Data_Ready	3

	TCP_Read_Data (DT ALEPKT)	
--	---------------------------	--

Table 5: Mapping of X.214 primitives to TCP

6.4.4 Addressing

6.4.4.1 Address Structure

- 6.4.4.1.1 The Euroradio FIS uses the ETCS-ID address information provided in the primitives to create transport selectors in the **T-Connect.Request** TPDU (CR TPDU) and the **T-Connect.Confirm** TPDU (CC TPDU). The full address information can be provided in the primitive parameters as described above.
- 6.4.4.1.2 When used in TCP/IP connections, this information supplied shall be used by the Adaptation Layer entity to retrieve the relevant port and IP address information and hence to establish a connection to the relevant remote entity.
- 6.4.4.1.3 The first 5 bits of the Application Type field specify the main application type. The minor application type (3 bits) specifies the main application types in more detail. §6.5.2 describes how this is transferred to the remote system. The Application Type of the calling and called peers shall be the same on both peers for a specific connection. The sender shall use the proper Application Type, the receiver can ignore it.
- 6.4.4.1.4 To preserve commonality with the Euroradio service provided over ISO Transport the format of the Application Type parameter used by the Adaptation Layer shall remain unchanged. The format and the values applicable are specified in Subset-037 §8.2.4.6.4 – Table 37.

6.4.5 Adaptation Layer Packet Format (ALEPKT)

- 6.4.5.1.1 One of the fundamental differences between the TCP and the ISO Transport Service is that the TCP manages a continuous stream of octets, with no explicit boundaries whereas TP2 handles well-bounded TPDU's.
- 6.4.5.1.2 To accommodate this difference, the Adaptation Layer uses a simple packetisation scheme in order to delimit information exchanged by TS-Users.
- 6.4.5.1.3 On receipt, an ALE is able to re-assemble each information packet previously embedded in the continuous stream of bytes coming from the TCP level.
- 6.4.5.1.4 The packets handled by the ALE are called ALEPKTs and are described below as an object of variable length composed of an integral number of octets. Unless otherwise stated, all fields are held in Big Endian byte order. An ALEPKT consists of two parts:
- a Packet Header
 - a TS-User Data PDU (User Data).
- 6.4.5.1.5 The format of the Packet Header is constant:

Packet	Version	Application	TSequence	N/R	Packet	Checksum	User Data
--------	---------	-------------	-----------	-----	--------	----------	-----------

Length		type	Number	Flag	Type		
<2 octets>	<1 octet>	<1 octet>	<2 octets>	<1 octet>	<1 octet>	<2 octets>	< variable length>

where:

Field Name	Length	Description
Packet Length	2 octets	Length of the entire ALEPKT in octets, excluding this 2-octets Packet Length field.
Version	1 octet	Used to identify the facilities offered by the Adaptation Layer to other parties. To be agreed between peer entities as part of the configuration. The Version parameter in ALEPKT may be ignored by the receiving ALE.
Application type	1 octet	Identifies application type, as specified in §6.4.4.1 The Application Type parameter in ALEPKT may be ignored by the receiving ALE.
T-Sequence Number	2 octets	Transport Sequence Number is used by the receiving Adaptation Layer to manage switching between two active TCP connections. The T-Sequence number field is not used for the class A. In this class, the value of the T-Sequence number is set to "0".
N/R Flag	1 octet	Used by the sending ALE to specify the normal or the redundant links on which the ALEPKTs are sent. The attribution of "normal" and "redundant" to the links is fixed during the configuration phase. The links shall be connected normal-normal and redundant-redundant. N= 1; R=0
Packet Type	1 octet	Description of the Type of Packet (used by Adaptation Layer to take appropriate action on receipt). A received ALEPKT containing a Packet Type not specified for the selected class of service shall cause the ALE to discard this packet. The receiving ALE may also close this TCP connection.
Checksum	2 octets	Checksum calculated (on the previous 6 fields totalling 8 bytes) as an FCS-16 used to identify if characters have been lost. The generator polynomial shall be CRC-CCITT ($x^{16}+x^{12}+x^5+1$). The Cyclic Redundancy Check (CRC) algorithm is specified in ISO/IEC 3309. The inversion (1's complement) of the CRC final result shall not be performed neither in the sending nor in the receiving entity. The highest term of the computed CRC (X16) shall correspond to the LSB of the Checksum field. See section 7.5 Table 14 in the Informative Annex for examples of Checksum results. A failed checksum shall cause the ALE to disconnect (and re-connect) this TCP connection, in order to ensure that ALEPKT boundaries are maintained. It is not required to check the Checksum for the keep alive messages of class A.
User Data	Variable	User Data of any legitimate length.

Table 6: ALEPKT information structure

6.5 Interface Protocol Definition

6.5.1 Using TCP/IP to provide ISO Transport Class 2 protocol

- 6.5.1.1.1 The model proposed in this document specifies a simple encapsulation mechanism allowing SaPDUs to be transferred using TCP. The encapsulated PDUs are known as ALE packets (ALEPKTs).
- 6.5.1.1.2 A service similar to the X.214 Transport Service, with minor but relevant modifications, running over TCP is defined. For the avoidance of doubt, X.214 and X.224 are not used by the CFM. They are only referred to as a means of explaining the functionality that is to be provided.
- 6.5.1.1.3 The Transmission Control Protocol (TCP) is used in place of X.224 to provide a CONS-like service. The relationship of these standards is illustrated below:

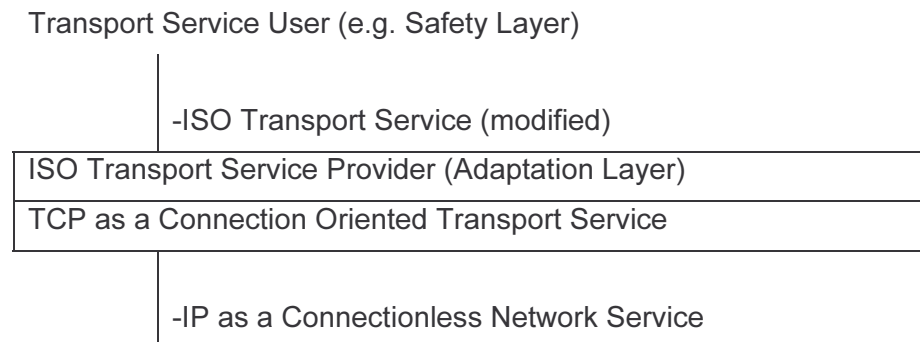

6.5.1.2 Emulating Class 2 over TCP

- 6.5.1.2.1 ISO Transport Class 2 provides the functions needed for connection establishment with negotiation, data transfer with segmentation, and protocol error reporting. It provides the Transport Connection with flow control based on that of the NS-provider. It provides Explicit Transport Disconnection.
- 6.5.1.2.2 The table below identifies whether ISO TP2 functions are relevant or available when TCP is used. Where the absence of a function is relevant to the operation of the service offered this is discussed in detail later in this section.

6.5.1.3 Mapping of Normal Procedure elements of TP2

Protocol mechanism	Paragraph X-ref of X.224	Variant or Option	TP Class 2	Used over TCP	not used over TCP	Comment

Protocol mechanism	Paragraph X-ref of X.224	Variant or Option	TP Class 2	Used over TCP	not used over TCP	Comment
Assignment to network connection	6.1.1		x	*		The adaptation layer shall contain a table that allows calls by the local safety entity to be mapped to a TCP port+IP address combination. If the TCP connection is not already established it shall be created.
TPDU transfer	6.2		x	*		Data as presented by the safety layer shall be transferred using the standard data transfer features of
Segmenting and reassembling	6.3		x		*	Long messages shall be transferred in more than one MTU. As TCP presents a stream of bytes rather than discrete data units it is necessary to identify and bound SaPDUs.
Concatenation and separation	6.4		x		*	This facility is not relevant to TCP.
Connection establishment	6.5		x	*		Normal TCP protocol is used
Connection refusal	6.6		x	*		Normal TCP protocol is used
Normal release	6.7	Explicit	x	*		Normal TCP protocol is used
Error release	6.8		x	*		Normal TCP protocol is used
Association of TPDUs with transport connection	6.9		x	*		TCP port addresses shall be used to distinguish the association. The Adaptation Layer shall manage the allocation of port numbers to connections (normally SRC-ref and DST-ref are used in TP2).
TPDU numbering	6.10	Normal Extended			*	Recovery, flow control and re-sequencing are dealt with by other functions when using TCP
Expedited data transfer	6.11	Network Expedited			*	Not supported in this Requests using HP-DATA primitives shall be rejected by the adaptation layer.
Reassignment after failure	6.12		N/A		*	Not used in TP2. Connections shall be managed by the Adaptation Layer.
Retention and acknowledgement of TPDUs	6.13	Confirmat ion of receipt	N/A		*	Not used in TP2 and not relevant when using TCP

Protocol mechanism	Paragraph X-ref of X.224	Variant or Option	TP Class 2	Used over TCP	not used over TCP	Comment
Re synchronisation	6.14		N/A		*	Not used in TP2.
Multiplexing and de-multiplexing	6.15		x		*	Achieved by using one TCP port per logical connection.
Explicit flow control	10.2		X		*	Normal TCP control is used
Checksum	6.17		x		*	Not relevant when using TCP. TCP's own algorithms protect data.
Frozen references	6.18				*	Not relevant when using TCP
Re transmission on time-out	6.19		N/A		*	Not normally used by TP2. Handled by TCP timeout and timeout-action parameters
Re-sequencing	6.20		N/A		*	Not normally used in TP2. Dealt with by TCP.
Inactivity control	6.21		N/A		*	Actually important to detect un-signalled network loss (through termination or loss of remote entity) . Handled by TCP timeout and timeout-action parameters
Treatment of protocol errors	6.22		X	*		TCP uses STATUS and ERROR primitives
Splitting and recombining	6.23		N/A		*	Not used by TP2. Not relevant when using TCP.

Table 7: Mapping of Normal Procedure elements of TP2

NOTES:

X Procedure always included in class 2

N/A Not applicable in TP class 2

6.5.1.3.1 The TCP protocol Service Access Point (*TCP SAP*) offers a set of specified service access primitives to the service user (*TCP-User*). The specification RFC0793 describes a possible implementation of these primitive ones, which is repeated in the following table only for reference. Other implementations are possible (for instance through the standard "socket" interface), provided that interworking is preserved.

ACTIONS	DESCRIPTION
TCP_Listen_On_Port	TCP-User requires a PASSIVE Open on the given port.
TCP_Open_Port	TCP-User requires a ACTIVE Open to the given port.
TCP_Read_Data	Data is read by TCP-User from the connection.
TCP_Send_Data	Data is send by TCP-User on the connection.
TCP_Close	TCP-User closes the connection

	(<i>pending</i> data is sent).
TCP_Abort	TCP-User closes the connection (<i>pending</i> data is lost).
TCP_Status	TCP-User requires information concerning the status of connection.
EVENTS	DESCRIPTION
TCP_Connected	Open succeeded (either ACTIVE or PASSIVE).
TCP_Connect_Fails	ACTIVE Open failed.
TCP_Data_Ready	Data is ready and it can be read from the connection
TCP_Errored	The connection is errored and is now closed.
TCP_Closed	An orderly disconnection has been completed.

Table 8: Service primitives in TCP

6.5.2 ALE operation

6.5.2.1 Creation of a Connection

6.5.2.1.1 To create a connection between TS-User entities a particular sequence of messages needs to be exchanged by them. This is accomplished by starting a 'transport' connection between Adaptation Layers using a TCP service, in the following way:

- Connections may be serviced in priority order according to Application Type.
- Address resolution shall be carried out by the Adaptation Layer, if required.
- Each request for a connection shall be serviced by new and individual TCP connection(s).

6.5.2.1.2 The TCP connection is established using standard procedures to deal with the issues arising if both peers simultaneously request a connection to each other. Parameters for the Adaptation Layer and its underlying TCP connections are described below.

6.5.2.2 Address Mapping

6.5.2.2.1 Address mapping is local implementation matter. An example of a possible implementation is provided in the Informative Annex §7.2

6.5.2.2.2 Addressing details have to agreed between peer entities.

6.5.2.3 Connection establishment

6.5.2.3.1 The creation of connections between two TS-User entities is achieved by using the primitive T-Connect.Request. This causes the establishment of one or more transport connections between Adaptation Layer entities which use the TCP service.

6.5.2.3.2 Each connection established between TS-User entities is uniquely identified from:

- An ordered couple of ETCS-ID

Calling ETCS-ID

Called ETCS-ID (Responding ETCS-ID)

- an Application Type.

6.5.2.3.3 Unless network addresses are explicitly specified in the T-Connect.Request, the Adaptation Layer shall obtain the information (Address + IP Port) from its own local configuration data.

6.5.2.4 Detailed protocol sequence

6.5.2.4.1 The ALEPKT exchange between Adaptation Layer entities during the connection establishment phase is as follows:

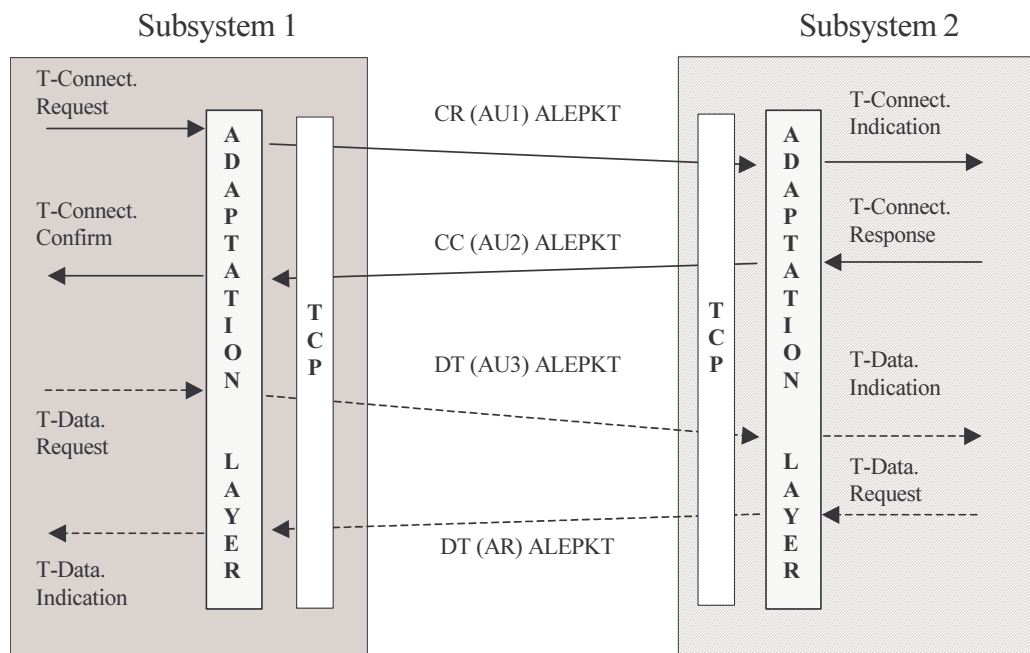

Figure 32: Safe Connection establishment: Detailed protocol sequence

6.5.2.4.2 The **AU1** ALEPKT (CR) has the following format:

AU1 ALEPKT – Initiator to Responder (Packet Type 1)				
ALEPKT Header	Adaptation Layer Connection Information			ALEPKT User Data
Header fields	Calling ETCS-ID ¹⁰	Called ETCS-ID ¹	Class of service	AU1 SaPDU
10 octets	4 octets	4 octets	1 octet	

¹⁰ It includes both fields ETCS-ID ERTMS and ETCS-ID type as described in Subset-037.

- 6.5.2.4.3 TS-User Initiator shall provide its own unique identifier (Calling ETCS-ID), the unique identifier of the TS-User called user (Called ETCS-ID) and the type of application (Application Type) for which the connection is required.
- 6.5.2.4.4 The Adaptation Layer shall not process the User Data and shall not manage this part of the packet. If it is present it shall be forwarded unchanged to the appropriate TS-User
- 6.5.2.4.5 The packet AU1 ALEPKT shall contain in the User Data the authentication information AU1 SaPDU, conforming to the format specified in Subset-037.
- 6.5.2.4.6 The Responder shall be able to refuse or accept the request for connection establishment, through the T-Connect.Response or the T-Disconnect.Request, returning its unique identifier (Responding ETCS-ID) to the Initiator.
- 6.5.2.4.7 If a connection is accepted then the AU2 ALEPKT (CC) is sent and has the following format:

AU2 ALEPKT – Responder to Initiator (Packet Type 2)

ALEPKT Header	Adaptation Layer Connection Information	ALEPKT User Data (optional)
Header fields	Responding ETCS-ID ¹	AU2 SaPDU
10 octets	4 octets	

- 6.5.2.4.8 With this phase of message exchange complete, the transport connection shall have been established.
- 6.5.2.4.9 The TS-User carries out a further ALEPKT exchange to complete the related safe connection set-up:

DT ALEPKT – Initiator to Responder (Packet Type 3)

ALEPKT Header	ALEPKT User Data
Header fields	AU3 SaPDU as described in Subset-037
10 octets	

DT ALEPKT – Responder to Initiator (Packet Type 3)

ALEPKT Header	ALEPKT User Data
Header fields	AR SaPDU as described in Subset-037
10 octets	

6.5.2.4.10 From the point of view of the Adaptation Layer, this last sequence is a normal exchange of data between two application users of the service so it is considered beyond the scope of the transport connection establishment specification.

6.5.2.5 Mapping over TCP/IP

6.5.2.5.1 **Note:** The descriptions in this section are for information only. Other implementations which use different primitives are possible, provided that there is no impact on interworking.

6.5.2.5.2 The OSI connection model requires that the transport provider obtain the explicit permission of the transport users to establish a connection. Thus for every connection between TS-User entities, the Calling ETCS-ID which is the Initiator shall request the action T-Connect.Request and the Called ETCS-ID which is the Responder shall have to wait for the T-Connect.Indication event and explicitly reply with a T-Connect.Response.

6.5.2.5.3 The TCP connection model differs from ISO model in a subtle but significant way. In the TCP model, the responding transport user is passive and does not intervene explicitly in the TCP connection process.

6.5.2.5.4 This means that before receiving a T-Connect.Request, the Adaptation Layer that is running in the Responder, must be already listening for a connection request to arrive, through a TCP_LISTEN_ON_PORT on the couple (Address+ IP Port).

6.5.2.5.5 As is normal TCP practice received calls are allocated to their own unique socket and the LISTEN can, if appropriate, remain posted to accept other incoming calls.

6.5.2.5.6 TCP also permits the establishment of a transport connection between two transport users that issue simultaneous connection requests. ISO does not. Simultaneous symmetric connection requests in the OSI model shall result in two transport connections.

6.5.2.5.7 Generally, this is of academic importance, since the active and passive nature of Initiators and Responders is such that simultaneous symmetric connections are avoided.

6.5.2.5.8 For a successful connection the relative sequence of actions/events between ISO TP2 and TCP is as follows:

Initiator ISO	Client TCP	Data	Server TCP	Responder ISO
			TCP_Listen _On_Port	
T-Connect.Request				
	TCP_Open_Port			
			TCP_Connected (Accepted)	
	TCP_Connected			
	TCP_Send_Data	CR AU1		

		ALEPKT		
			TCP_Data_Ready	
			TCP_Read_Data	
			(ALEPKT check)	
				T-Connect.Indication
				T-Connect.Response
		CC AU2 ALEPKT	TCP_Send_Data	
	TCP_Data_Ready			
	TCP_Read_Data			
	(ALEPKT check)			
T-Connect.Confirm				

6.5.2.5.9 And for an unsuccessful connection is:

Initiator ISO	Client TCP	Data	Server TCP	Responder ISO
			TCP_LISTEN_ON_PORT	
T-CONNECT.REQUEST				
	TCP_OPEN_PORT			
			TCP_CLOSE (REJECTED)	
	TCP_CONNECT_FAILS			
T-DISCONNECT.INDICATION				

Table 9: Connection establishment mapping between TP2 actions/events and TCP

6.5.2.6 Creation of the connection

- 6.5.2.6.1 Every connection between two subsystems is realised through one or two transport connections. Where two connections are required they should be established on routes sufficiently diverse to guarantee the required availability level (as matter of the implementation).
- 6.5.2.6.2 For every connection request either active (T-Connect.Request) or passive (T-Connect.Indication), the Adaptation Layer shall have to allocate a sequential counter Transport Sequence Number containing the sequence number value of the ALEPKT to be sent.
- 6.5.2.6.3 Each Transport Sequence Number is coded in 2 bytes (*unsigned int16*) using the Big Endian data representation, and therefore it shall assume values between 0 and 65535.
- 6.5.2.6.4 This counter of ALEPKT packets shall be initialised to “0” before the connection procedure starts. Consequently, AU1 and AU2 ALEPKTs shall always have Transport

Sequence Number = 0. For Class D connections each subsequent transmission of an ALEPKT shall increase the value of this counter by one.

6.5.2.6.5 Where a T-Connect.Request fails, the Initiator shall always be responsible for trying to re-establish the connection.

6.5.3 Data transfer

6.5.3.1 Introduction

6.5.3.1.1 Data transfer is effected by means of the primitive T-Data.Request and T-Data.Indication using an ALEPKT of the format described below.

6.5.3.1.2 The TS-User can use data of any format in the User Data field of the of the ALEPKT type 3.

6.5.3.1.3 There is a limitation on the size of the data PDU which is different from the one normally imposed by ERTMS. To allow for the insertion of further header information the maximum size of the User Data PDU that can be transmitted is reduced from 65,536 to 65,000 bytes.

6.5.3.2 Detailed protocol sequence

6.5.3.2.1 The exchange of ALEPKT packets between the two entities of the Adaptation Layer in the data transfer phase is shown in the following figure:

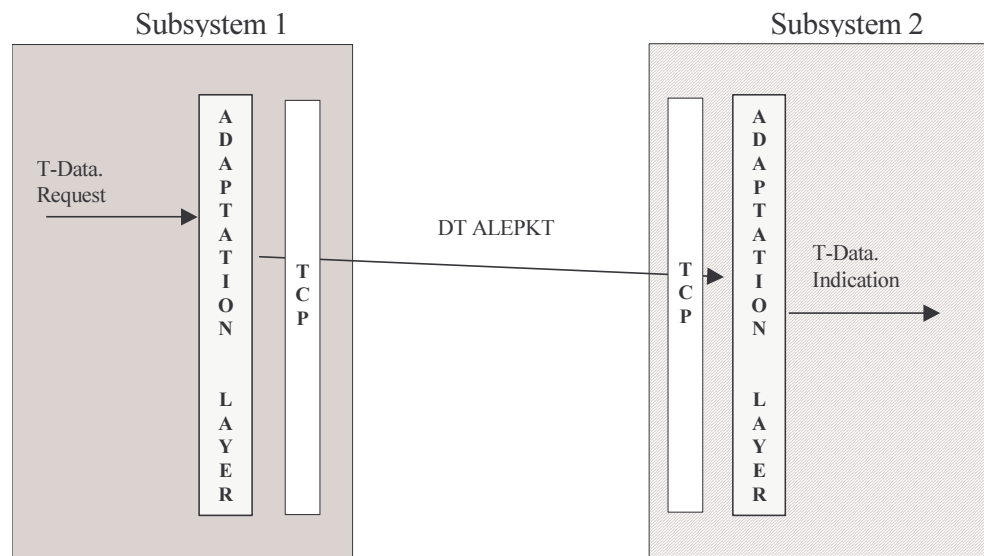

Figure 33: Detailed Data transfer protocol sequence

6.5.3.2.2 The DT ALEPKT (Data Transfer) has the following format:

DT ALEPKT – Sender to Receiver (Packet Type 3)

ALEPKT Header	ALEPKT User Data
Header fields	DT SaPDU
10 octets	

6.5.3.3 Mapping over TCP

- 6.5.3.3.1.1 **Note:** The descriptions in this section are for information only. Other implementations which use different primitives are possible, provided that there is no impact on interworking.
- 6.5.3.3.1.2 Data transfer in the TCP model differs from the ISO model in that instead of an event containing the received data (T-Data.Indication), only the availability of data is signalled (TCP_DATA_READY). The second part of the read action is the execution of the task (TCP_READ_DATA).
- 6.5.3.3.1.3 The relative sequence of actions/events between the levels ISO TP2 and TCP is as follows:

Xmt ISO	Xmt TCP	Data	Rcv TCP	Rcv ISO
T-DATA.REQUEST				
	TCP_SEND_DATA	DT ALEPKT		
			TCP_DATA_READY	
			TCP_READ_DATA	
			(ALEPKT check)	
				T-Data.Indication

- 6.5.3.3.1.4 The flow of the DT ALEPKT packets by T-Data.Request and T-Data.Indication between the TS-User entities shall be made in accordance with the Class of Service requested by the TS-User.

6.5.3.3.2 T-Data.Request:

- 6.5.3.3.2.1 The value of the Transport Sequence Number contained in the ALEPKT header is incremented by 1 at each sending of an ALEPKT.
- 6.5.3.3.2.2 If the Transport Sequence Number has reached the maximum value (65535), then its value shall be set to "0".

6.5.4 Connection release

6.5.4.1 Introduction

- 6.5.4.1.1 Two primitives apply to ISO-connection release: the T-Disconnect.Request action and the related T-Disconnect-Indication event.

6.5.4.1.2 The ISO connection release service T-Disconnect.Request is used by TS-User to:

- abandon connection establishment;
- release an established connection;
- indicate a failure to establish a connection;
- indicate a failure to maintain a connection.

6.5.4.1.3 Connection release is permitted at any time regardless of the current connection phase, and a request for release cannot be rejected by Adaptation Layer.

6.5.4.1.4 A connection can be terminated in one of two ways:

6.5.4.2 Non-Disruptive Disconnection

6.5.4.2.1 A non-Disruptive Disconnect requires that all queued TPDU's, that's TPDU previously provided by TS-User to the local TS-Provider, shall be sent and delivered to TS-User remote before the TCP connection is closed.

6.5.4.2.2 To reach this goal, the Adaptation Layer (TS-Provider) queues and transmits a DI ALEPKT in the output buffer, then releases the connection. Once data transfer is complete, the remote Adaptation Layer closes the connection and issues a T-Disconnect.Indication to its local user having Reason code normal.

6.5.4.3 Disruptive Disconnection

6.5.4.3.1 Where a disconnection is caused by some failure of the communications system then a Disruptive Disconnection shall take place. This method of disconnection shall not guarantee previous data delivery.

6.5.4.3.2 In this instance a T-Disconnect.Indication shall be passed by TS-Provider (Adaptation Layer) to both TS-Users with meaningful Reason and Sub Reason codes.

6.5.4.3.3 A key requirement is that a connection release required by *TS-User* via a T-Disconnect.Request must be performed by the Adaptation Layer using the non-disruptive method.

6.5.4.4 Detailed protocol sequence

6.5.4.4.1 If disconnection is at the request by the TS-User, the release of a Transport connection between two Adaptation Layer uses the following exchange of ALEPKT packets:

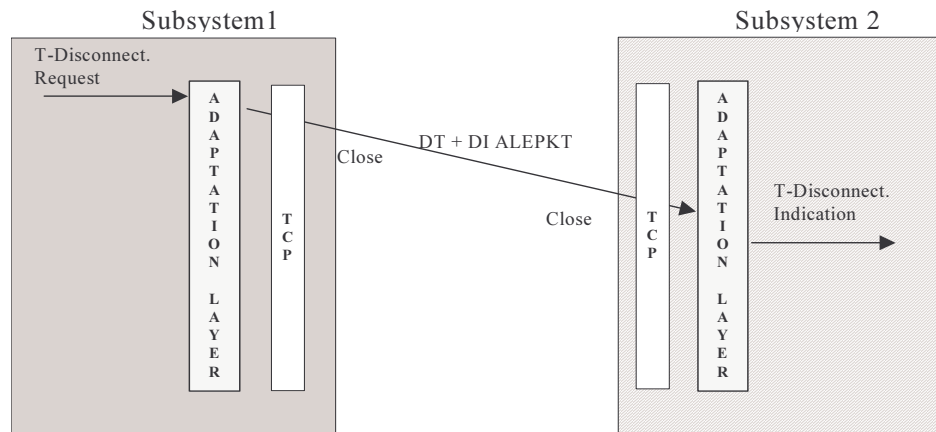

Figure 34: Non-disruptive Connection release detailed protocol sequence

6.5.4.4.2 The DI ALEPKT (Disconnect Indication) has the following format:

DI ALEPKT – Initiator to Responder (Packet Type 4)

ALEPKT Header	ALEPKT User Data
Header fields	
10 octets	DI SaPDU

6.5.4.4.3 The flow of ALEPKT packets between the two Adaptation Layer entities and the respective TS-User in consequence of some failure in the communication system (disruptive disconnect) is as follows:

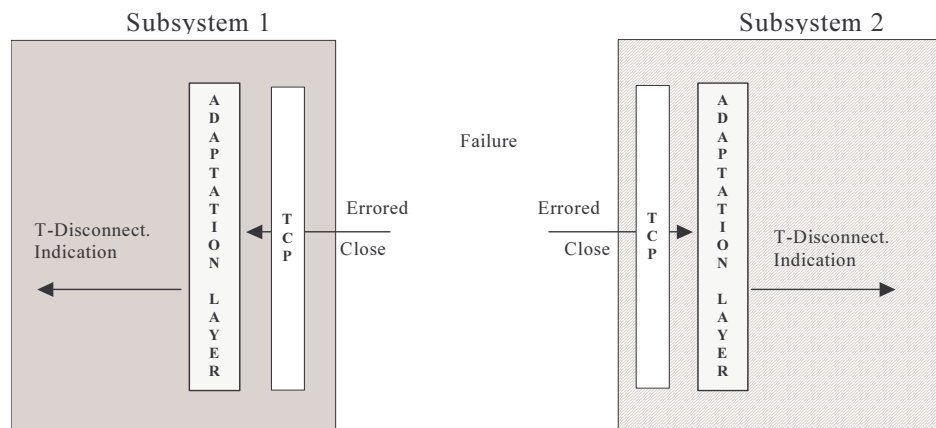

Figure 35: Disruptive Connection release detailed protocol sequence

6.5.4.5 Mapping over TCP

6.5.4.5.1 **Note:** The descriptions in this section are for information only. Other implementations which use different primitives are possible, provided that there is no impact on interworking.

- 6.5.4.5.2 The ISO connection release service is similar to the TCP connection abort service (TCP_CLOSE). However, unlike TCP, ISO does not support an orderly connection release. The transport provider does not guarantee delivery of any user data once the release phase is entered. This TCP form of release guarantees that any buffered data is delivered to the transport user before the connection is released. ISO merely guarantees that buffered data is delivered to the destination transport provider.
- 6.5.4.5.3 The TCP orderly release service is sometimes referred to as a “graceful closure”. Each transport user must agree to release the connection before the connection is dissolved, and until then, the TCP transport provider maintains the connection. Once a connection has been released by a transport user, no more data can be sent, but the user can continue to receive data. Any data previously sent is delivered to the destination transport user.
- 6.5.4.5.4 ISO-connection release service, provided by Adaptation Layer, shall cause all (one or more) associated TCP connections to be released.
- 6.5.4.5.5 The relative sequence of actions/events between the levels ISO TP2 and TCP is the following:

ISO	TCP	Data	TCP	ISO
T-DISCONNECT.REQUEST				
	TCP_SEND_DATA	DI ALEPKT		
	(wait)		TCP_Data_Ready	
			TCP_Read_Data	
	TCP_Close		(ALEPKT check)	
			TCP_Close	
	TCP_Closed		TCP_Closed	T-Disconnect.Indication

- 6.5.4.5.6 The remote TCP entity indicates to the Adaptation Layer entity that a connection has been closed through a TCP_CLOSED event. If the TCP connection has failed or has been rejected, the TCP indicates that the connection has been closed through a TCP_CONNECT_FAILS event.
 - 6.5.4.5.7 If the Adaptation Layer believes that a link is unusable for any other reason, then it shall remove the link using the primitive TCP_ABORT so issuing the TCP_ERRORED event to the other side of the connection.
- 6.5.4.6 Normal disconnection at the request of the TS-User**
- 6.5.4.6.1 When a TS-User wishes to terminate its relationship with a remote TS-User it does so using a T-Disconnect.Request. On receipt of this primitive the local Adaptation Layer shall close all TCP connections using the TCP_CLOSE action on each TCP connection that is open at the time of the request.

6.5.4.6.2 Once all data has been transferred (including the request) the TCP connection shall be closed in the other direction.

6.5.4.6.3 Note, in order to trigger the equivalent of a T-Disconnect.Indication event at the remote entity, *all* TCP connections associated with the Safety Layer connection must be closed. The remote TCP entity indicates to the local Adaptation Layer entity that a connection has been closed through the TCP_CLOSED event. When a closing TCP link is the last one remaining for a specific ISO connection the Adaptation Layer shall issue the T-Disconnect.Indication with appropriate error codes towards the TS-User.

6.5.4.7 Anomalous release by Adaptation Layer

6.5.4.7.1 In case of an anomalous disconnection by the local Adaptation Layer entity, all the TCP associated links shall be released using the TCP_CLOSE action. The user of the remote service shall be informed immediately as soon as the last TCP_CLOSED and shall produce the T-Disconnect.Indication event to the TS-user (as in the normal disconnection but with appropriate Reason and Sub-Reason parameters).

6.5.4.8 Anomalous release by TCP

6.5.4.8.1 The case of an anomalous release of a TCP link is more complex.

6.5.4.8.2 If the TCP link released for is the last, it shall cause the dispatch of the T-Disconnect.Indication event with appropriate error to the TS-User.

6.5.4.8.3 If any TCP channel being one of two links is released for some reason and the other link is still active, then the initiating Adaptation Layer shall try to restore the connection with the remote Adaptation Layer without informing the TS-User.

6.5.4.8.4 In the case of re-connect failure the Adaptation Layer shall have to try again for a maximum number of times after which it shall have to report the problem through T-Report.Indication with an appropriate error code to the TS-User or a management entity.

6.6 Operation and Redundancy Management for different Classes of Service

6.6.1 Class A (optional for implementation)

6.6.1.1 Definitions

6.6.1.1.1 If two links are used between ALE entities, one is configured as the normal one, and the other as the redundant one. This configuration is fixed.

6.6.1.1.2 If two links are used between two ALE entities, the link used to establish/release the ALE connection or to exchange ALE packets containing application data is called the "active link". The other link is called the "non-active link". In case of switching between the two links, the active link becomes the non-active link and conversely.

6.6.1.1.3 Normal/Redundant and Active/Non-Active are two different concepts. In this way, either the normal or redundant link can be active or non-active. Normal/Redundant is physically fixed, while active/non-active is dynamically assigned.

6.6.1.1.4 Class A is coded as 0x00.

6.6.1.2 ALE Connection establishment

6.6.1.2.1 If the normal link is available, this one shall initially be used to establish the ALE connection and transfer all user data ALEPKTs between the peers. This path shall have the N/R flag of the ALEPKT header set to value 1.

6.6.1.2.2 As soon as practicable, a second TCP connection shall also be started between two alternative IP addresses for the peers on a different physical link. This connection shall be used as the redundant link if required. The N/R flag for any messages sent on this connection shall have the N/R flag set to 0.

6.6.1.2.3 In case of non availability of the normal link, the redundant link shall be used to establish the ALE connection and to transfer all user data ALEPKTs between the peers. The N/R flag for any messages sent on this connection shall have the N/R flag set to 0.

6.6.1.2.4 The initiator chooses the link that will be used to exchange packet type 1 and 2 - this will be the active link for the initiator. The packet type 1 and 2 shall not be exchanged on the non-active link. When the responder receives the packet type 1 from one link, this becomes the active one for the responder. The packet type 2 shall be sent on this active link. The initiator shall check that packet type 2 is received on the active link. In case of failure of the check, the ALE connection shall be released.

6.6.1.2.5 The use of packet types 3, 251, 253, 254 and 255 is not allowed before ALE connection establishment (exchange of packet types 1 and 2).

6.6.1.2.6 Class A shall be able to operate, without redundancy, on one single physical link and one single TCP connection. In this case the N/R flag shall be set to 1.

6.6.1.3 Data Transfer

6.6.1.3.1 Data ALEPKTs shall be transferred on the active link as described in §6.5.3. When no packet is available for transmission on the active link and a 'Keep Alive' timer configured for this connection has expired then an ALEPKT header with the packet type set to '255' (KAA = Keep Alive Active) shall be sent on this link.

6.6.1.3.2 To check the availability of the non-active link, a 'Keep Alive' packets shall also be sent in both directions on this link whenever a timer configured for this connection has expired. The packet type of the 'Keep Alive' shall set to value '254' (KANA = Keep Alive Non Active). There shall be no user data.

6.6.1.3.3 If the non-active link is available, the "keep alive" packet on the non-active link (packet type 254) shall be exchanged between the two peer entities after the connection establishment at the ALE level.

- 6.6.1.3.4 When one of the following messages is received:
- a packet type 254 (Keep Alive Non-Active) on the active link
 - a packet type 255 (Keep Alive Active) on the non-active link
 - a packet type 3 (Data Message) on the non active link
- then the corresponding switch packet:
- packet type 251 (data will be sent on the redundant link)
 - or packet type 253 (data will be sent on the normal link))
- shall be sent to the peer device.

6.6.1.4 Redundancy Management

- 6.6.1.4.1 When the active link has failed, data transfer shall be switched to the non-active link.
- 6.6.1.4.2 If the active link is the normal link, the switch shall be achieved by either peer sending a SwitchN2R ALEPKT with the packet type set to value '251' on the redundant link. User data may be sent in this packet in the normal way. This allows the peer that first detects the error to switch communication paths, thus reducing switch times following a failure. The receiver of a packet type '251' shall send and receive any future data packets on the redundant link.
- 6.6.1.4.3 Once data transfer is properly established on the redundant link then the Adaptation Layer that originated the call shall attempt to re-establish the 'normal' link connection. When successful, the Adaptation Layer shall use 'Keep Alive' packets for non-active link to monitor the 'normal' connection. However, data transfer shall not revert to this link unless a problem is detected on the redundant link. When needed this shall be achieved by either Adaptation Layer sending, on the normal link, a SwitchR2N ALEPKT with the type set to the value '253'. User data may be sent in this packet in the normal way.
- 6.6.1.4.4 If the active link is the redundant link and it fails, the switch shall be achieved by either peer sending a SwitchR2N ALEPKT with the packet type set to value '253' on the normal link. User data may be sent in this packet in the normal way. The receiver of a packet type '253' shall send and receive any future data packets on the normal link.
- 6.6.1.4.5 Once data transfer is properly established on the normal link, the Adaptation Layer that originated the call shall attempt to re-establish the redundant link connection. When successful, the Adaptation Layer shall use 'Keep Alive' packets for non-active link to monitor the redundant link connection. However, data transfer shall not revert to this link unless a problem is detected on the normal link. When needed this shall be achieved by either Adaptation Layer sending, on the redundant link, a SwitchN2R ALEPKT with the type set to the value '251'.
- 6.6.1.4.6 Note that the message type of the 'Keep Alive' depends on whether a link is being used to transfer data or not. It does not depend on whether the link is the nominated normal or redundant path. The link transferring data always uses 'Keep Alive' packet type

'255', the link that is available as a standby always uses 'Keep Alive' packet '254'. This technique enables the system to quickly recover if 'switch' messages are lost or delayed. (If a '254' packet is received on the new active link after a switch message has been sent then another switch message should be transmitted until either data or '255' messages are received on the active link).

6.6.1.5 Normal release

6.6.1.5.1 When a Safety Layer entity wishes to terminate its relationship with a remote entity it does so using a T-Disconnect.Request. The DI ALEPKT is exchanged on the active link. On receipt of this primitive the local Adaptation Layer shall close all TCP connections using the TCP-CLOSE primitive on each TCP connection that is open at the time of the request. Once all data has been transferred (including the request) the TCP connection shall be closed in the other direction.

6.6.1.5.2 A packet type 4 (DI) can be sent only in the following cases:

by the initiator after the packet type 1 was sent;

by the responder after the packet type 1 type was received.

Note, in order to trigger the equivalent of a T-Disconnect.Indication at the remote entity, all TCP connections associated with the Safety Layer connection shall be closed. The remote TCP entity indicates to the Adaptation Layer entity that a connection has been closed through TCP-CLOSING event. When a TCP connection is the last remaining for this Safety Layer relationship then this triggers the Adaptation Layer to send a T-Disconnect.Indication with appropriate reason codes to its local Safety Layer.

6.6.1.6 Abnormal release

6.6.1.6.1 In the case of an abnormal release by the local Safety Layer entity, all associated TCP connections are released using TCP-CLOSE. The remote service user is to be immediately informed when the last TCP-CLOSING event triggers the T-Disconnect.Indication primitive (as in normal release but with different codes described in §6.7).

6.6.1.6.2 The case of abnormal release of a TCP connection is more complex.

6.6.1.6.3 If a TCP connection is the last remaining this triggers a T-Disconnect.Indication with appropriate reason codes.

6.6.1.6.4 If the released connection is the non-active link (the active link being still available) then the Adaptation Layer shall attempt to re-connect to the remote entity without informing the Adaptation Layer user.

6.6.1.6.5 If the connection closed is the active link and the non-active link is still operating then the Adaptation Layer shall first switch all data transfer to the non-active link before attempting to re-establish the normal connection. .

6.6.1.6.6 If the link that notifies the Adaptation Layer of connection loss is the last remaining circuit then this triggers a T-Disconnect.Indication with appropriate reason codes. It

must be stressed that in order to trigger a T-Disconnect.Indication, all TCP connections associated with the Safety Layer connection must be closed. The remote TCP entity indicates to the Adaptation Layer entity that a connection has been closed through TCP-CLOSING event. If the TCP connection has failed the TCP indicates that the connection has been closed through TCP-ERROR event.

- 6.6.1.6.7 If the Adaptation Layer believes that a connection is unusable for some reason then it may remove the connection using the ABORT primitive. Unless this is the last TCP connection open it shall not inform the Safety Layer.

6.6.2 Class D

6.6.2.1 Connection

- 6.6.2.1.1 For Class D, all ALEPKTs are sent on all connections. Transport connections shall support one single safe connection between two entities. One TCP connection shall be created at the same time on each physical link.

- 6.6.2.1.2 One, two or more physical links may be used. This section is written assuming two physical links. The following requirements should be modified to reflect the number of physical links available.

- 6.6.2.1.3 For example, on one single physical link (no redundancy) and therefore one single TCP connection, the N/R flag shall be set to '1'.

- 6.6.2.1.4 Connection Establishment packets AU1 ALEPKT (CR) and AU2 ALEPKT (CC) complete with User Data, shall be sent in an identical way on both the TCP transport connections using the Transport Sequence Number value of "0".

- 6.6.2.1.5 During the connection establishment phase, the ALE entity shall use the first AU1 and AU2 ALEPKT received, and discard any copies received.

- 6.6.2.1.6 Class D is coded as 0x03.

6.6.2.2 Data Transfer

- 6.6.2.2.1 All Data ALEPKTs shall be transferred on both TCP connections. The same Transport Sequence Number shall be transmitted on both TCP connections.

- 6.6.2.2.2 The receiver shall observe the ALEPKTs received on both TCP connections.

- 6.6.2.2.3 The receiver shall discard any ALEPKT with a Transport Sequence Number which has the same value as (or less than) an ALEPKT that has already been passed to the TS user.

- 6.6.2.2.4 At least two different behaviours are possible at the receiver side:

- a) An ALE packet containing a Transport Sequence Number greater than the last one delivered to the ALE user shall be passed to the ALE user.

- b) An ALE packet containing a Transport Sequence Number equal to the 'previous Transport Sequence Number delivered to the ALE user + 1' shall be passed to the ALE user. Packets containing a Transport Sequence Number greater than the last one +1 shall be discarded.

6.6.2.2.5 The choice between a) and b) is a configuration matter.

6.6.2.2.6 Behaviour b) has to be selected if no missing ALEPKT is allowed.

6.6.2.2.7 In the case of any failure of the data transfer on one TCP channel, the Adaptation Layer shall not make any attempt to resolve the problem, but shall simply release the connection and reject the data; this failure can be reported to the ALE user, as an implementation matter.

6.6.2.3 Redundancy Management

6.6.2.3.1 When a transmitter is unable to send data on a TCP connection or a TCP connection is deemed in error the TCP connection shall be closed. The sending of Data ALEPKTs through the other link shall continue. The Adaptation Layer entity that initiated the original connection (the initiator) shall attempt to re-establish any failed TCP connection.

6.6.2.3.2 At the receiver, any TCP connection deemed to have failed shall be closed. The receiver shall take no further action unless it was the initiator of the TCP call. In this case it shall attempt to re-establish the connection.

6.6.2.3.3 All ALEPKTs shall be taken from the remaining TCP connection.

6.6.2.4 Connection Monitoring

6.6.2.4.1 Connection and physical link monitoring in Class D shall be performed using the standard Keep Alive feature provided by TCP.

6.6.2.4.2 Both TCP entities shall enable the Keep Alive feature.

6.6.2.4.3 NOTE: In case the Application is sending data in a cyclic way, connection monitoring at TCP level is not required.

6.6.3 Summary of ALEPKT

6.6.3.1.1 This section summarises the various ALEPKTs used by ALE.

ALEPKT Type	ALEPKT name	scope	User Data	link	Class using
1	AU1 (CR)	Request a connection to peer	AU1	Class D: N and R Class A: active link	A & D

2	AU2 (CC)	Accept a connection from peer	AU2	Class D: N and R Class A: active link	A & D
3	DT	Transfer user data	SaPDU	Class D: N and R Class A: active link	A & D
4	DI	Release a connection	DI SaPDU	Class D: N and R Class A: active link	A & D
251	SwitchN2R	Switch data traffic to the R link	None or SaPDU	R	A
253	SwitchR2N	Switch data traffic to the N link	None or SaPDU	N	A
254	KANA	Keep alive on non active link	none	Non active	A
255	KAAs	Keep alive on active link	none	Active	A

Table 10: Summary of ALEPKTs

6.7 Management of Adaptation Layer - ALEPKT Error Handling

6.7.1.1 Supervision/Diagnostics

- 6.7.1.1.1 As with the normal Euroradio service the Adaptation Layer should wherever possible keep communications faults hidden from the TS-User entity. Only when the problem cannot be solved should the Adaptation Layer user be informed.
- 6.7.1.1.2 Unrecoverable errors reported by the network shall be notified via the Adaptation Layer to the Safety Layer.
- 6.7.1.1.3 Where a ALEPKT fails its checksum the Adaptation Layer Entity shall reset the TCP connection on which it was received.
- 6.7.1.1.4 Where errors are received from the primary TCP connections of Class A services then action shall be taken according to the rules described in §6.6.1.
- 6.7.1.1.5 Where the Adaptation Layer cannot maintain transparent service the following errors shall be handled and reported to the user by the Adaptation Layer entity. The table 11 identifies some possible reasons and sub-reasons and describes possible corresponding error handling action at transport level. Other actions are still possible,

for specific implementations. Reason and sub-reason codes are local implementation matter.

Reason		Sub-reason		Handling action
Code	Description	Code	Description	
0	Normal release	0		Indication passed to the user in the reason parameter of the T-Disconnect.Indication .
1	Network error	1	Number not assigned; invalid number format	Error indication is created by the local Adaptation Layer and passed to the user in the reason parameter of the T-Disconnect.Indication .
		2	Channel QoS is unacceptable	
		3	Impossible to establish physical connection for other reasons	
		4	Address information incompatible with QoS requested.	
2	Network resource not available	1	No channel available	Indication of a transient error is created by the Adaptation Layer and is contained in the reason parameter of the T-Disconnect.Indication
		2	Network congestion	
		3	Other sub-reason	
3	Service or option is temporarily not available	1	QoS not available	Indication of a transient error is created by the Adaptation Layer and is contained in the reason parameter of the T-Disconnect.Indication
		2	Bearer capability not available	
5	Reason unknown	0		Error indication is created by the called Adaptation Layer and is contained in the reason parameter of the T-Disconnect.Indication .
6	Unsupported Application	1	Requested Application type is not supported at the called address	Error indication is created by the called Adaptation Layer and is contained in the user data of the DR-ALEPKT (type 4) . The calling Adaptation Layer shall report the error to the calling application using the T-Disconnect.Indication with the corresponding reason and sub-reason codes.
		2	Called user not known (e.g. No reply)	
		3	Called user not available (e.g. Busy)	
7	Internal error	1	Mandatory element (e.g. primitive parameter) is missing	Error logged. Invalid message discarded. Indication passed to the user in the reason parameter of the T-Disconnect.Indication .
		2	Inappropriate state	
		3	Other sub-reasons	
Note: All other reason/sub-reasons are reserved				

Table 11: Error reports

6.8 Lower layers of protocol stack

6.8.1 Introduction

6.8.1.1.1 It is not the intention of this specification to restrict the way in which an underlying network solution is to be implemented. As such only minimum criteria for interworking are to be applied.

6.8.2 TCP Parameter Negotiation (Mandatory)

6.8.2.1.1 The parameters that must be taken into account in TCP connection establishment by the Adaptation Layer are restricted to those described below:

6.8.2.2 Max MTU size

6.8.2.2.1 The default values are 576 bytes for routed WAN links and 1500 for Ethernet LANs. This parameter is directly mapped to the TCP parameter and determines the maximum size of a Message Transfer Unit. Messages exceeding this size shall be sent in multiple IP datagrams. This value is varied to optimise performance over different physical media.

6.8.2.2.2 Using the IP default datagram size of 576 octets means that an ALEPKT should be less than 512 bytes if it is desired to transmit it in a single IP datagram (by allowing 64 bytes for headers and trailers - see also notes on D bit and fragmentation). The choice of 1460 bytes for Ethernet LANs is to allow for IEEE 802.3 frame sizes between 64 and 1518 bytes (assuming headers and trailers totalling up to 58 bytes).

6.8.2.2.3 This parameter in no way restricts the maximum message size that can be transmitted. This is 65,536 bytes less the header sizes detailed above. In this specification a maximum message size of 65,000 bytes is recommended (slightly under the maximum SaPDU size allowed which is 64kB). Note that it is also possible to set a Max Segment Size (MSS) between TCP entities that defines the maximum TCP segment size that shall be transmitted.

6.8.2.3 Keep Alive acknowledgement timer (for Class D only)

6.8.2.3.1 This parameter is identical to the TCP parameter and allows user applications to be notified when their network service times out. The time shall vary according to the application requirements.

6.8.3 Network Service Definition

6.8.3.1.1 A standard TCP service shall be used over a standard IP network layer complying with all associated RFCs.

6.8.3.1.2 This specification should not restrict usage of newer IP versions like IPv6, see [RFC2460].

6.8.4 Network Protocol

6.8.4.1.1 The implementation shall be conformant to the IP standard [RFC0791] that describes IPv4.

6.8.4.1.2 It should be seen that messages that do not exceed the lengths of MTU described in §6.8.2.2 shall not be fragmented by the IP layer and shall be transmitted in a single MTU.

6.8.4.1.3 To maximise performance implementers should take care to ensure that the MTU size is set to the smallest size relevant to the media in the path and not necessarily to the size that is determined by the RBC connection itself.

6.9 Adaptation Layer Configuration and Management

6.9.1 General

6.9.1.1.1 The configuration defines the parameters needed for the execution of the Adaptation Layer protocol and the management of the Adaptation Layer itself.

6.9.2 Timer Parameter

6.9.2.1.1 The parameter 'maximum connection establishment delay' is used for detecting unacceptable delay during the connection establishment. This parameter value shall vary according to the application but by default is 40 seconds (the same as the Safety protocol see §5.3.1.1.5).

6.9.3 Call and ID-Management (Adaptation Layer and TCP)

6.9.3.1.1 Addressing conventions and mapping rules are matter of bilateral agreement for a specific project.

7. INFORMATIVE ANNEX

7.1 TCP Parameter Negotiation

7.1.1 TCP Service options

7.1.1.1.1 Other optional features of TCP/IP may be used to provide a particular level of service. It should be noted however that how QoS is achieved is a matter of implementation and is not prescriptive. This said, meeting QoS requirements could result in a number of possible actions including

- The creation of multiple connections between end systems
- The use of options within TCP such as push and urgent flags (possibly for high priority data)
- The setting of IP 'Type of Service' options such as

Precedence : 3 bits signifying one of 8 levels of precedence
 Low delay : D flag - at each hop select route with least known delay
 High throughput : T bit - routers should select path with highest throughput
 High reliability : R bit - network uses connection oriented links if available
 Least 'cost' : C bit - (if available) select route with lowest cost

7.1.1.1.2 It must be noted that 'Type of Service' parameters are only useful if the intermediate systems such as routers can act on them.

7.1.1.1.3 The following parameters passed from TCP to IP may also be useful

- DF bit (don't fragment) - choose a network route that can handle the whole datagram rather than fragmenting it. Note, if set, the receiving host shall either receive the data in a single datagram or not at all.
- MF bit (more fragments) - use this facility where messages are fragmented to indicate that more fragments are still to come.

7.2 Address Mapping

7.2.1.1.1 This section provide an example of a possible implementation of the address mapping.

7.2.1.1.2 On receipt of the connect request from the TS-User entity (with address information as described in §6.4.4 the Adaptation Layer performs the following actions.

7.2.1.1.3 If the **T-Connect.Request** contains full addressing information (meaning that the **Network Address** field of the Safety Layer User Connect Request contains a value

- that is not null or “0”) the Adaptation Layer attempts to establish transport connection(s) using this information. (Note that for this to be successful a correct TCP address must be defined.
- 7.2.1.1.4 If only ETCS-ids are contained in the **T-Connect.Request** (the Network Address is null) then the Adaptation Layer performs the necessary look-up (via tables or some other database) to obtain the full TCP addresses required to establish the connection.
 - 7.2.1.1.5 If the **Application Type** in the **T-Connect.Request** so determines then the local Adaptation Layer seeks to establish two connections to the remote Adaptation Layer.
 - 7.2.1.1.6 If there is no network address or no ETCS-ID contained in the **T-Connect.Request** primitive or there is a mapping error, the call has to be established towards the most appropriate system by means of an agreed convention (or rejected with an appropriate message sent to a supervisory management system).
 - 7.2.1.1.7 The network address (port and IP address) by itself is not sufficient to identify a particular remote Transport Service user entity. It is also necessary to refer to the requested Transport Service user entity type by using a special identifier or address qualifier, the **application type** contained in every ALEPKT.
 - 7.2.1.1.8 Adaptation Layer entities and the Service user entities are bound together at TSAPs. Every Adaptation Layer Service user entity may be bound to one or more TSAPs. This is a matter of implementation. There is no relationship between TSAPs and multiplexing. Each connection regardless of its TSAP id **must** be mapped to an individual TCP port for the purpose of establishing a real connection. In the case of Class A or D relationships a second TCP connection is also established and used as described in §6.6.
 - 7.2.1.1.9 If a Transport Service user entity (e.g. the safety layer entity) wants to establish a connection with another Transport Service user entity, it provides information to address the called Transport Service user (usually an ETCS-ID and the application type, possibly the network address). This address information has to be mapped into the format and structure requested by the TCP Service for connection establishment. This is done by the Adaptation Layer, which is accessed by the Safety Layer Entity at one or more TSAPs.

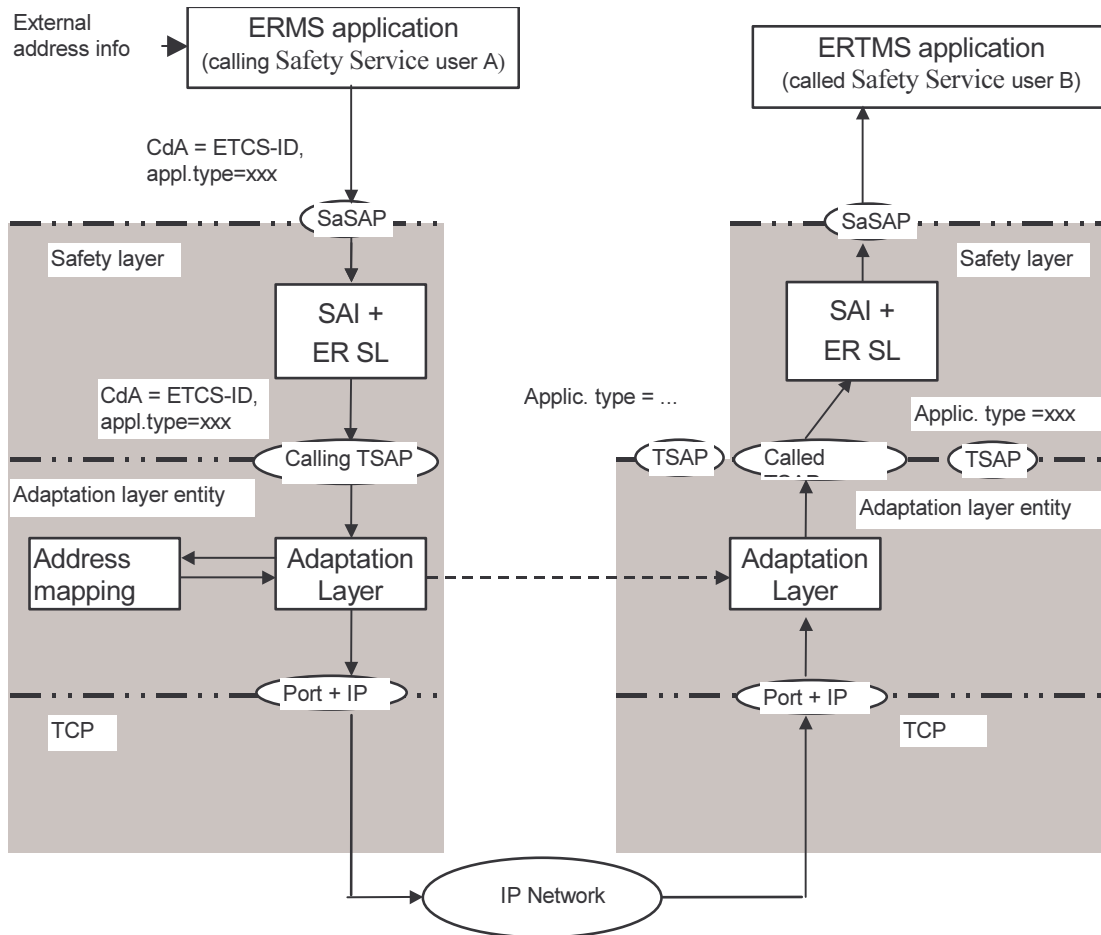

Figure 36: Example of address mapping

7.2.1.1.10 The diagram above gives an example of address information mappings during the connection establishment between Transport Services. The calling TS user entity (i.e. in this example the safety layer entity) obtains the called address from the application (ETCS-ID). The address information is be passed through the Safety Layer towards the Adaptation Layer Transport Service. The Adaptation layer entity has the following tasks:

- to listen for incoming connections. A TCP LISTEN is posted on each and every port willing to accept incoming connections. As is normal TCP practice received calls are allocated to their own socket and the LISTEN remains posted;
- to derive the called network address (TCP/IP address) from address information indicating the called Transport Service User (unless it is already provided by the SLE);
- to generate the appropriate ALEPKTs as defined later in this section.

7.3 Data Link Layer

7.3.1 Ethernet

7.3.1.1 Logical Link Control

7.3.1.1.1 The data link layer for the connection of the system to a network should be appropriate to its type.

7.3.1.1.2 For Ethernet it shall use LLC1 unacknowledged connectionless service to provide support for the IP network layer. This is the standard protocol used to interconnect IP devices over CSMA/CD LANs.

7.3.2 Media Access Control

7.3.2.1.1 This should be according to standard and appropriate to the media.

7.3.3 Wide Area connections

7.3.3.1.1 Wide Area connections may use X.25, HDLC, Frame Relay or PPP or other datalink protocols, depending also on the media used.

7.4 Guideline for Key Management

7.4.1 Scope

7.4.1.1.1 Key management (KM) functions are required to establish interoperable services.

7.4.1.1.2 In the ERTMS system, when an RBC wishes to communicate with another RBC, it shall be able to verify that communication is established with an authorised RBC and vice versa. Consequently the authenticity and integrity of any information exchanged between RBCs is also verified.

7.4.1.1.3 This guideline covers management of cryptographic keys as defined in UNISIG EuroRadio FIS [Subset-037]. It describes general concepts, principles, and functions to manage cryptographic materials used by the EuroRadio safety layer.

7.4.1.1.4 The procedures and aspects of key management inside a KM domain for trackside entities are a matter of operational implementation by the railways.

7.4.2 KM Concepts and Principles

7.4.2.1 Introduction and background

7.4.2.1.1 The method of ensuring that both communicating entities are the ones they assert to be, is based on an Identification and Authentication (I&A) dialogue. In order to ensure

complete protection, this procedure shall take place each time the peer entities effectively start a new communication session between them.

- 7.4.2.1.2 After each successful I&A dialogue, data are protected using a Message Authentication Code (MAC). The calculation of this code is based on the existence of shared secret information only known by the entities that are actually communicating with each other.
- 7.4.2.1.3 Both I&A dialogue and MAC calculation procedures are fully specified in the Safety Functional Module described in UNISIG EuroRadio FIS [Subset-037]. These procedures are based on cryptographic techniques that use secret keys. However, Subset-037 does not specify any means to generate, distribute or update these keys.
- 7.4.2.1.4 Moreover, their full efficiency relies on the key secrecy that can only be guaranteed when clear key management functions and system security policy are defined according to implementation constraints and railway operational scenarios.

7.4.3 Phases and parties involved In KMS

- 7.4.3.1.1 Two different phases should be considered to define the parties involved in KMS:
 1. During system development and commissioning (i.e. before authorisation to service).
 2. During system operation.
- 7.4.3.1.2 During phase 1 the following parties are involved:
 - Suppliers of ETCS equipment
 - Contracting entities
- 7.4.3.1.3 During phase 2 at the present state of the organisation of railways and probably valid also for the near future, the following parties are involved:
 - Key Management Centres (KMC)
 - Infrastructure Managers (i.e. Operators of trackside ETCS equipment)

An Infrastructure Manager can perform the functions of KMC, for instance, but it is also possible that other companies (even not belonging to the “railway world”) offer this service.
- 7.4.3.1.4 The concept of parties is used in this guideline only to identify a role and a set of “homogeneous” responsibilities. No assumption is made on any other aspect. In other words, two or more different parties identified above may be the same organisation, may be different departments of the same organisation, may be separate undertakings, etc. Similarly, the organisations involved in any part of the KMS functions may regulate their relationships and reciprocal responsibilities by means of agreements, contracts, etc., that are out of the scope of this guideline.

7.4.4 General Principles

- 7.4.4.1.1 The following figure summarises the KMS context for RBC-RBC safe communication:

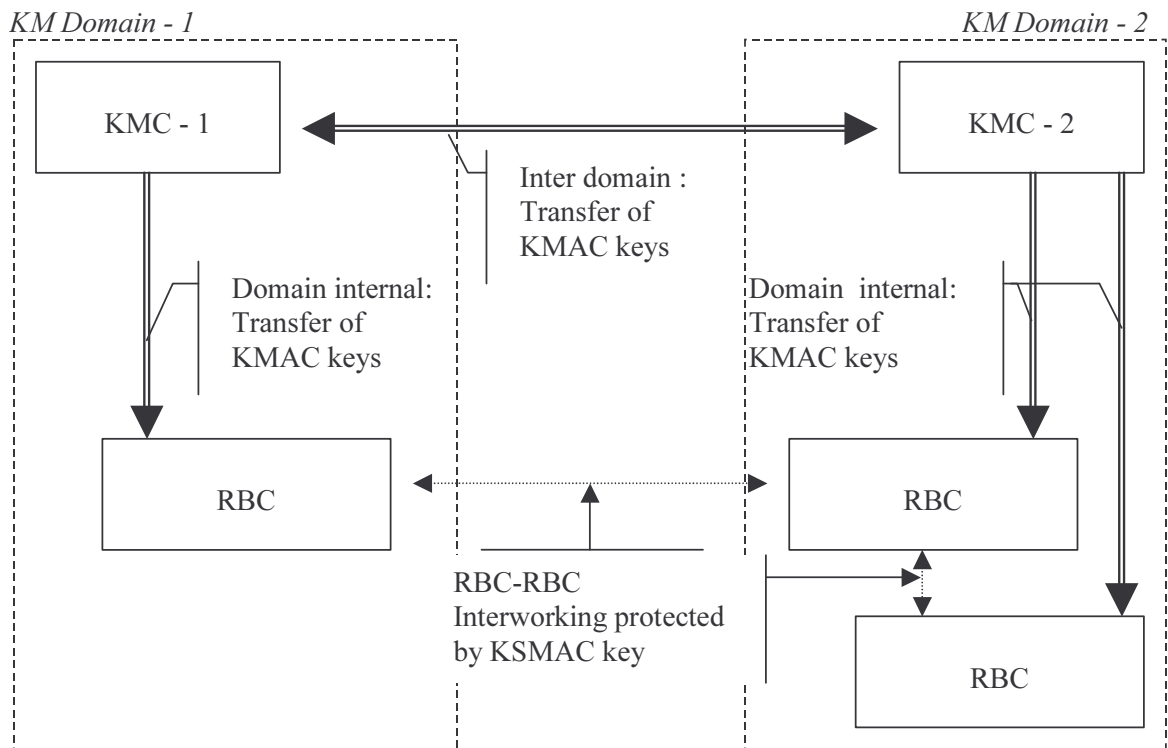

Figure 37: KM context diagram

- 7.4.4.1.2 The KMAC transfer indicated in the figure is used to distribute, update and delete KMACs.
- 7.4.4.1.3 A home KMC is responsible for generation, validation, distributing, updating and revoking KMAC to all RBCs of its domain. Therefore each RBC shall use only their home KMC for key management purposes.
- 7.4.4.1.4 For KMC interworking, a FIS (Functional Interface Specification) is required at the KMC-KMC interface. This is the purpose of [Subset-038], which describes the principles and procedures including the use of additional keys required to exchange KMACs and allow interoperable train traffic between KM domains.

7.4.5 Key Hierarchy

- 7.4.5.1.1 This guideline is compliant to the key hierarchy defined in [Subset-037].

Level	Purpose
-------	---------

3 : Transport key KTRANS	Protection of KMS communication between KMC and RBC. Each KMC-RBC relation needs a KTRANS.
2 : Authentication key KMAC	Authentication of ERTMS entities during EuroRadio safe connection establishment. Each RBC-RBC relation needs a KMAC.
1 : Session key KSMAC	Authentication of data transfer between RBCs by a safe connection. This key is derived from KMAC during establishment of the safe connection and is only used during the lifetime of this safe connection.

Table 12: Key hierarchy

7.4.5.1.2 KTRANS keys are composed of two keys: K-TRANS1 is used for protecting the authenticity and integrity of the messages exchanged between KMC and RBC. K-TRANS2 is used to protect by encryption the KMAC exchanged between KMC and RBC.

7.4.5.1.3 The following table summarises the different types of key and their respective usage:

Involved entities	Key used for Identification & Authentication	Key used for message authentication	Key used for encryption	notes
RBC – RBC	KMAC	KSMAC	---	RBC-RBC interworking
KMC – RBC	---	KTRANS1	KTRANS2	KM domain internal transfer of KMAC

Table 13: Use of the defined keys

7.4.6 Key assignment

7.4.6.1.1 Each RBC shall be equipped with KMACs for each possible relation to adjacent authorised RBCs.

7.4.6.1.2 The assignment of KMAC keys is a matter of the KM domain according to the system security policy.

7.4.6.1.3 If an open network is used for communication between RBC, different KMACs should be assigned to each RBC-RBC relation.

7.4.6.1.4 In case of closed networks, a unique KMAC may be assigned to all RBC-RBC relations inside a KM domain.

7.4.6.1.5 The KMAC may be installed in RBCs in different KM domains: in the home KM domain and any foreign KM domain. KMAC generation and assignment has to be agreed between KM domain administrators. The exchange of KMAC via KM domain border is specified by [Subset-038].

7.4.7 Basic KM Functions

7.4.7.1 List of functions

7.4.7.1.1 In order to allow perform secure and consistent key exchange between KMC and RBC any key management system shall support the following functions:

- Generate and validate KTRANS
- Distribute KTRANS
- Generate and validate KMAC
- Distribute KMAC
- Update KMAC
- Delete KMAC
- Archive keys and KM transactions

Note: Exchange of RBC KMAC with another KMC is out of scope for this guideline (see Subset-038).

7.4.7.2 Generation and validation of KTRANS and KMAC

7.4.7.2.1 Only authorised persons and processes in a well-defined organisation and secure environment shall generate keys for encryption and decryption or for authentication. The keys should be generated randomly to prevent possible prediction.

7.4.7.2.2 All keys generated shall be checked to guarantee that they are not weak or semi-weak.

7.4.7.2.3 KTRANS and KMAC generation and validation shall be performed by the KMC according to security requirements of interoperable ERTMS applications. Specific technical solutions do not need harmonisation (provided security is ensured).

7.4.7.3 Distribute KTRANS

7.4.7.3.1 The distribution of keys in a KM domain shall take place between the KMC and RBC. The theft or loss of key material shall be detected and unauthorised persons shall not be able - or only with a very high effort - to modify keys.

7.4.7.3.2 The delivering KMC Administrator shall indicate which RBC-RBC relation that KTRANS is intended for.

7.4.7.3.3 The receiving RBC shall confirm reception and take the necessary action to put the KTRANS in operation.

7.4.7.3.4 The key shall be sent confidentially and is installed in the RBC by some staff intervention.

7.4.7.4 Distribute KMAC

7.4.7.4.1 The delivering KMC Administrator shall indicate which RBC-RBC relation that KMAC is intended for.

- 7.4.7.4.2 The receiving RBC shall confirm reception and take the necessary action to put the KMAC in operation.
- 7.4.7.4.3 The key shall be sent confidentially by encryption with KTRANS2.
- 7.4.7.4.4 Key installation in RBC entities shall be under the responsibility of the KMC. It shall be performed in a secure way and include all related key information.
- 7.4.7.4.5 Keys shall be stored in such a way that they remain authentic and confidential.

7.4.7.5 Update KMAC

- 7.4.7.5.1 The KMC Administrator decides when it is appropriate to update the KMAC. The decision to update a key is taken according to a predefined key renewal plan or in case of detection of hazardous situations (loss of confidentiality).
- 7.4.7.5.2 It should be possible to update KMAC during both maintenance and normal operation.
 Note 1: updating during maintenance is intended for introduction or removal of RBC entities.
 Note 2: updating during operation is intended for non-interruptible entities like RBCs.

7.4.7.6 Delete KMAC

- 7.4.7.6.1 Key deletion shall be under the responsibility of the KMC domain. It shall be performed in a secure way and include all related key information.
- 7.4.7.6.2 All possible copies of the key material shall be deleted including installed keys in RBCs except the key archive under KMC responsibility.
- 7.4.7.6.3 The KMC Administrator shall be able to initiate key deletion.
- 7.4.7.6.4 The RBC shall confirm to the originator of the request that the key deletion has been completed.

7.4.7.7 Archive keys and KM transactions

- 7.4.7.7.1 All keys, key related material and associated key transactions shall be archived by the KMC in an authentic and confidential way, including:
 - Assignment of keys to entities
 - State of the key (currently used, deleted, compromised)

7.4.8 Abbreviations and Definitions

- 7.4.8.1.1 This section contains some additional abbreviations and definitions related to key management.

Abbreviation	Definition
--------------	------------

Abbreviation	Definition
KM	Key Management
KMAC	Authentication Key
KMC	Key Management Centre
KMS	Key Management System (Implementation of Key Management)
KSMAC	Session Key
KTRANS	Transport Key

Term	Definition
Authentication	Used between two entities to corroborate the identity of the entities and the source of information
Confidentiality	Used to prevent information from being read by unauthorised entities.
Domain	One domain is defined by one KMC and all the on-board and trackside entities using that KMC for key management purposes
Key archive	Long term storage of keys, which must be authentic and confidential.
Key deletion	Deletion of keys incl. all related information and copies.
Key generation	Confidential generation of key related material used for encryption, decryption and key derivation.
Key installation	Confidential installation of keys into the entities.
Key management	The generation, storage, secure distribution, revocation, destruction and application of keying material.
Key Management Centre	The functional entity which is responsible for the key management functions.
Keying material	The data (e.g., keys) necessary to establish and maintain cryptographic keying relationships.
KMC Administrator	The KMC Administrator shall assume responsibility for all key management administration functions within one domain.
Secure environment	A secure place or a specially developed device. Under normal circumstances it should not be possible for unauthorised persons to read out any information from this special place or device.
Security	The protection resulting from all measures, including administrative, designed to prevent accidental or malicious modification or disclosure of data. For key management the protection generally guarantees confidentiality, authenticity and integrity of keys.
Validity time	Time for which the keys are valid.

7.5 Examples of Checksum results

Packet Length	Version	Appl.Type	TSeqNum	N/R Flag	Packet Type	Checksum
001E	01	1A	0000	01	01	1089
0021	01	1A	0000	01	02	F38E
0011	01	1A	0001	01	03	8D12
002A	01	1A	0002	01	03	C6E0
000B	01	1A	0003	01	04	57A0

Table 14 : Example of Checksum result – all values are in hex