

ERTMS/ETCS – Class 1
Test Specification for Interface 'K' and Interface 'G'
REF : SUBSET-102 ISSUE : 1.0.0 DATE : October 4, 2005

Company	Technical Approval	Management approval
ALCATEL		
ALSTOM		
ANSALDO SIGNAL		
BOMBARDIER		
INVENSYS RAIL		
SIEMENS		

MODIFICATION HISTORY

Issue Number Date	Section Number	Modification / Description	Author
0.0.1, 2004-12-17		Initial draft.	P. Lundberg
0.0.2 2004-12-22	4.1.6	Including determination of ASK Up-link signal level.	P. Lundberg
0.0.3 2005-03-01		Including updating reflecting the latest version of SUBSET-101.	P. Lundberg
0.0.4 2005-03-10		Update considering discussions from the fourteenth WGKI meeting.	P. Lundberg
0.0.5 2005-04-14		Update considering discussions from the fifteenth WGKI meeting.	P. Lundberg
0.0.6 2005-04-21	4.1.6, Annex E, Annex F	Including further elaboration.	P. Lundberg
0.0.7 2005-05-13		Update considering discussions from the sixteenth WGKI meeting.	P. Lundberg
0.0.8 2005-06-15	5.2.8	Including additional test cases for side lobe management.	P. Lundberg
0.0.9 2005-08-05	4.2.3.2, 4.2.3.4, 4.3.2.3, 4.3.3.4, 5.3.4.3, 5.3.8	Including test cases for side lobe management in alternative 2 and conclusions from the seventeenth WGKI meeting.	P. Lundberg
0.1.0 2005-09-02		Update considering conclusions from the eighteenth WGKI meeting.	P. Lundberg
1.0.0 2005-10-04	5.2.4.4	Final update.	P. Lundberg

Foreword

This specification details how to verify the Interface 'K' properties defined in UNISIG SUBSET-101 ("Interface 'K' Specification). It also involves some Interface 'G' properties defined in UNISIG SUBSET-100 that are crucial for the On-board behaviour.

To some extent, methods and test tools are identical to what apply for Eurobalise. In these cases, UNISIG SUBSET-085 is referenced.

Contents

1	SCOPE	11
2	REFERENCES	12
3	TERMINOLOGY AND DEFINITIONS	13
3.1	Acronyms and Abbreviations	13
3.2	Definitions	13
3.3	Influence of Tolerances	13
4	TESTS OF THE ON-BOARD TRANSMISSION EQUIPMENT	14
4.1	Reference Test Configuration	14
4.1.1	General	14
4.1.2	Generic Test Set-up	15
4.1.3	Generic Test and Calibration Set-up Notes	17
4.1.4	Test Conditions	19
4.1.4.1	Nominal Conditions	19
4.1.4.2	Specific Conditions	21
4.1.5	Test Tools and Procedures	22
4.1.6	Determination of ASK Up-link Signal Level	23
4.1.7	Calibration of Up-link data generation	24
4.2	Laboratory Tests, Alternative 1 Interface	25
4.2.1	Electrical Data	25
4.2.1.1	General Description, Electrical Data	25
4.2.1.2	Conditions, Electrical Data	25
4.2.1.3	Acceptance Criteria, Electrical Data	25
4.2.2	Data Transmission	26
4.2.2.1	General Description, Data Transmission	26
4.2.2.2	Test Pattern, Data Transmission	26
4.2.2.3	Test Procedure, Data Transmission	26
4.2.2.4	Acceptance Criteria, Data Transmission	26
4.2.3	Timing Requirements	27
4.2.3.1	General Description, Timing Requirements	27
4.2.3.2	Test Pattern, Timing Requirements	27
4.2.3.3	Test Procedure, Timing Requirements	27
4.2.3.4	Acceptance Criteria, Timing Requirements	27
4.2.4	Functional Data	28

4.2.4.1	General Description, Functional Data	28
4.2.4.2	Test Patterns, Functional Data	28
4.2.4.3	Test Procedure, Functional Data	29
4.2.4.4	Acceptance Criteria, Functional Data	30
4.2.5	Link Check Functionality	32
4.2.5.1	General Description, Link Check Functionality	32
4.2.5.2	Test Pattern, Link Check Functionality	32
4.2.5.3	Test Procedure, Link Check Functionality	32
4.2.5.4	Acceptance Criteria, Link Check Functionality	33
4.2.6	Verification of Transmission and Bit Stream Requirements	35
4.2.6.1	General Description, Transmission and Bit Stream Requirements	35
4.2.6.2	Evaluation of Radiation Pattern	36
4.2.6.3	Creation of Signal Pattern for Dynamic Tests	40
4.2.6.4	Transmission Tests	46
4.2.6.5	Electrical Tele-powering Characteristics	49
4.2.6.6	Maximum Flux Level	49
4.2.6.7	Up-link Characteristics	51
4.2.6.8	Cross-talk Immunity	52
4.2.6.9	Cross-talk Immunity with Cables	55
4.2.6.10	Balise Detect Ability Supervision	56
4.3	Laboratory Tests, Alternative 2 Interface	57
4.3.1	Electrical Data	57
4.3.2	Data Transmission	57
4.3.2.1	General Description, Data Transmission	57
4.3.2.2	Test Pattern, Data Transmission	57
4.3.2.3	Test Procedure, Data Transmission	57
4.3.2.4	Acceptance Criteria, Data Transmission	57
4.3.3	Timing Requirements	58
4.3.3.1	General Description, Timing Requirements	58
4.3.3.2	Test Pattern, Timing Requirements	58
4.3.3.3	Test Procedure, Timing Requirements	58
4.3.3.4	Acceptance Criteria, Timing Requirements	58
4.3.4	Functional Data	59
4.3.4.1	General Description, Functional Data	59
4.3.4.2	Test Patterns, Functional Data	59
4.3.4.3	Test Procedure, Functional Data	59
4.3.4.4	Acceptance Criteria, Functional Data	59

4.3.5	Link Check Functionality	60
4.3.5.1	General Description, Link Check Functionality	60
4.3.5.2	Test Pattern, Link Check Functionality	60
4.3.5.3	Test Procedure, Link Check Functionality	60
4.3.5.4	Acceptance Criteria, Link Check Functionality	60
4.3.6	Verification of Transmission and Bit Stream Requirements	61
4.4	Requirements for Test Tools	61
5	TESTS OF THE STM	62
5.1	Reference Test Configuration	62
5.1.1	General	62
5.1.2	Generic Test Set-up	62
5.1.3	Generic Notes	63
5.1.4	Test Conditions	64
5.1.4.1	General	64
5.1.4.2	Climatic Conditions	64
5.1.4.3	RS 485 Conditions	64
5.1.4.4	Time and Odometer Conditions	64
5.1.4.5	Test Sequences and Telegram Content	64
5.1.5	Test Tools and Procedures	65
5.2	Laboratory Tests, Alternative 1 Interface	66
5.2.1	Electrical Data	66
5.2.1.1	General, Electrical Data	66
5.2.1.2	Conditions, Electrical Data	66
5.2.1.3	Acceptance Criteria, Electrical Data	66
5.2.2	Data Transmission	67
5.2.3	Timing Requirements	67
5.2.3.1	General Description, Timing Requirements	67
5.2.3.2	Test Pattern, Timing Requirements	67
5.2.3.3	Test Procedure, Timing Requirements	68
5.2.3.4	Acceptance Criteria, Timing Requirements	68
5.2.4	Functional Data	69
5.2.4.1	General Description, Functional Data	69
5.2.4.2	Test Pattern, Functional Data	69
5.2.4.3	Test Procedure, Functional Data	70
5.2.4.4	Acceptance Criteria, Functional Data	72
5.2.5	Link Check Functionality	74
5.2.5.1	General Description, Link Check Functionality	74

5.2.5.2	Test Pattern, Link Check Functionality	74
5.2.5.3	Test Procedure, Link Check Functionality	74
5.2.5.4	Acceptance Criteria, Link Check Functionality	75
5.2.6	Handling of Diversified Data	75
5.2.7	Detection of Balises	76
5.2.7.1	General Description, Detection of Balises	76
5.2.7.2	Test Pattern, Detection of Balises	76
5.2.7.3	Test Procedure, Detection of Balises	76
5.2.7.4	Acceptance Criteria, Detection of Balises	76
5.2.8	Management of Side Lobe Effects	77
5.2.8.1	General Description, Management of Side Lobe Effects	77
5.2.8.2	Test Pattern, Management of Side Lobe Effects	77
5.2.8.3	Test Procedure, Management of Side Lobe Effects	85
5.2.8.4	Acceptance Criteria, Management of Side Lobe Effects	85
5.2.9	Telegram Decoding	90
5.2.9.1	General Description, Telegram Decoding	90
5.2.9.2	Test Pattern, Telegram Decoding	90
5.2.9.3	Test Procedure, Telegram Decoding	90
5.2.9.4	Acceptance Criteria, Telegram Decoding	90
5.3	Laboratory Tests, Alternative 2 Interface	91
5.3.1	Electrical Data	91
5.3.2	Data Transmission	91
5.3.3	Timing Requirements	91
5.3.3.1	General Description, Timing Requirements	91
5.3.3.2	Test Pattern, Timing Requirements	91
5.3.3.3	Test Procedure, Timing Requirements	92
5.3.3.4	Acceptance Criteria, Timing Requirements	92
5.3.4	Functional Data	93
5.3.4.1	General Description, Functional Data	93
5.3.4.2	Test Pattern, Functional Data	93
5.3.4.3	Test Procedure, Functional Data	94
5.3.4.4	Acceptance Criteria, Functional Data	95
5.3.5	Link Check Functionality	96
5.3.5.1	General Description, Link Check Functionality	96
5.3.5.2	Test Pattern, Link Check Functionality	96
5.3.5.3	Test Procedure, Link Check Functionality	96
5.3.5.4	Acceptance Criteria, Link Check Functionality	96

5.3.6	Handling of Diversified Data	97
5.3.7	Detection of Balises	97
5.3.7.1	General Description, Detection of Balises	97
5.3.7.2	Test Pattern, Detection of Balises	97
5.3.7.3	Test Procedure, Detection of Balises	97
5.3.7.4	Acceptance Criteria, Detection of Balises	97
5.3.8	Management of Side Lobe Effects	98
5.3.8.1	General Description, Management of Side Lobe Effects	98
5.3.8.2	Test Pattern, Management of Side Lobe Effects	98
5.3.8.3	Test Procedure, Management of Side Lobe Effects	104
5.3.8.4	Acceptance Criteria, Management of Side Lobe Effects	105
5.3.9	Telegram Decoding	108
5.3.9.1	General Description, Telegram Decoding	108
5.3.9.2	Test Pattern, Telegram Decoding	108
5.3.9.3	Test Procedure, Telegram Decoding	108
5.3.9.4	Acceptance Criteria, Telegram Decoding	108
5.4	Requirements for Test Tools	108
ANNEX A, MEASUREMENT POINTS		109
A1	TEST POINTS FOR CONTACT ZONE AND SIDE-LOBE ZONE	109
A2	TEST POINTS FOR CROSS-TALK PROTECTED ZONE	110
A3	TEST MATRIX FOR TRANSMISSION AND CROSS-TALK TESTS	111
A3.1	Test Conditions versus Test Zones	111
A3.2	Test Conditions versus Geometrical Test Points	111
A4	TEST MATRIX FOR OTHER CHARACTERISTICS	112
A4.1	Test Conditions versus Characteristics	112
A4.2	Test Conditions versus Geometrical Test Points	112
ANNEX B, TEST TOOLS AND INSTRUMENTS		113
B1	RECOMMENDED TEST TOOLS AND INSTRUMENTS	113
ANNEX C, INTERFACE 'V_K'		114
C1	GENERAL	114
C2	CONFIGURATION DATA	114
C2.1	Test Case Selection (TESTCASE)	114

C2.2	Adapter Status (ADAPSTAT)	117
C2.3	Link Status (ALIVE)	119
C3	TEST DATA	119
C3.1	Test Report (TEST_REP)	119
C4	PHYSICAL CONTROL	122
C4.1	General	122
C4.2	Architecture	122
C4.3	Interface 'V_K', Mechanical Data	123
C5	LINK CONTROL	125
C5.1	General	125
C5.2	Interface 'V_K'	125
C6	LINK SYNCHRONISATION	127
C6.1	General	127
C6.2	The Interface Adapter is switched on before the Interface 'V_K' driver	127
C6.3	The Interface 'V_K' driver is switched on before the Interface Adapter	128
C6.4	The Interface 'V_K' driver is re-started but the Interface Adapter remains on	129
C6.5	The Interface Adapter is re-started but the Interface 'V_K' driver remains on	130
C6.6	Behaviour of the Interface 'V_K' driver	131
	ANNEX D, INTERFACE 'K' ADAPTER	132
D1	GENERAL	132
D2	FUNCTIONAL REQUIREMENTS	132
D3	SUGGESTED BLOCK DIAGRAM, ALTERNATIVE 1	133
	ANNEX E, TOOLS NEEDING EXTENDED FUNCTIONALITY	134
E1	GENERAL	134
E2	LABORATORY MANAGEMENT SYSTEM (LTMS)	134
E2.1	General	134
E2.2	External Interfaces	134
E2.3	Test Sequences	134
E3	REFERENCE SIGNAL GENERATOR (RSG_1)	135
E3.1	General	135

E3.2	External Interfaces	135
E3.3	Required Performance	135
ANNEX F, INTERFACE 'V_K' ADAPTER		136
F1	GENERAL	136
F2	FUNCTIONAL REQUIREMENTS	136
F2.1	GENERAL	136
F2.2	RADIATION PATTERN TEST AND TRANSMISSION TESTS	136
F2.3	FUNCTIONAL DATA TESTS	137
F2.4	LINK CHECK FUNCTIONALITY TESTS	138
F3	PHYSICAL REQUIREMENTS	139
F3.1	INTERFACE 'K' CONNECTORS	139
F3.2	CONNECTOR FOR TRIGGER FROM RSG_1	140
F4	ELECTRICAL REQUIREMENTS	140
F4.1	GENERAL	140
F4.2	ISOLATION	140
F4.3	TRIGGER FROM RSG_1	140

1 Scope

This specification defines the specific set of verifications suitable for the verification of the properties of Interface ‘K’ defined through UNISIG SUBSET-101.

Since there is tight relation between the Interface ‘K’ properties and the air gap properties, also some characteristics related to the Interface ‘G’ specification (UNISIG SUBSET-100) are subject to testing herein. This includes transmission tests, tests for the capability of handling the Up-link signal, and cross-talk tests.

Involved units are On-board Antenna Units integrated with the transmission functionality of the overall On-board ATP equipment, and the related KER STM’s.

The verifications dealt with in this specification are aimed at ensuring full and safe interoperability between On-board equipment of any supplier and related KER STM’s.

Verification of system oriented aspects (such as correct selection of On-board Transmission Equipment at changed travelling direction and redundancy switchover, correct activation of toggling Tele-powering, etc.) are not within the scope of this specification.

The specific test set-ups presented herein are recommendations only, and should primarily be regarded of principal nature. However, they are detailed enough to provide a solid basis for designing actual test set-ups, and they do include hints on important properties. Modifications are allowed as long the measurement accuracy is maintained, the same results are obtained, and the same properties are explored. There might in some cases be a need for additional precautions not to destroy specific instruments (due to high power levels).

Figure 1 below recalls the overall architecture defined in UNISIG SUBSET-101.

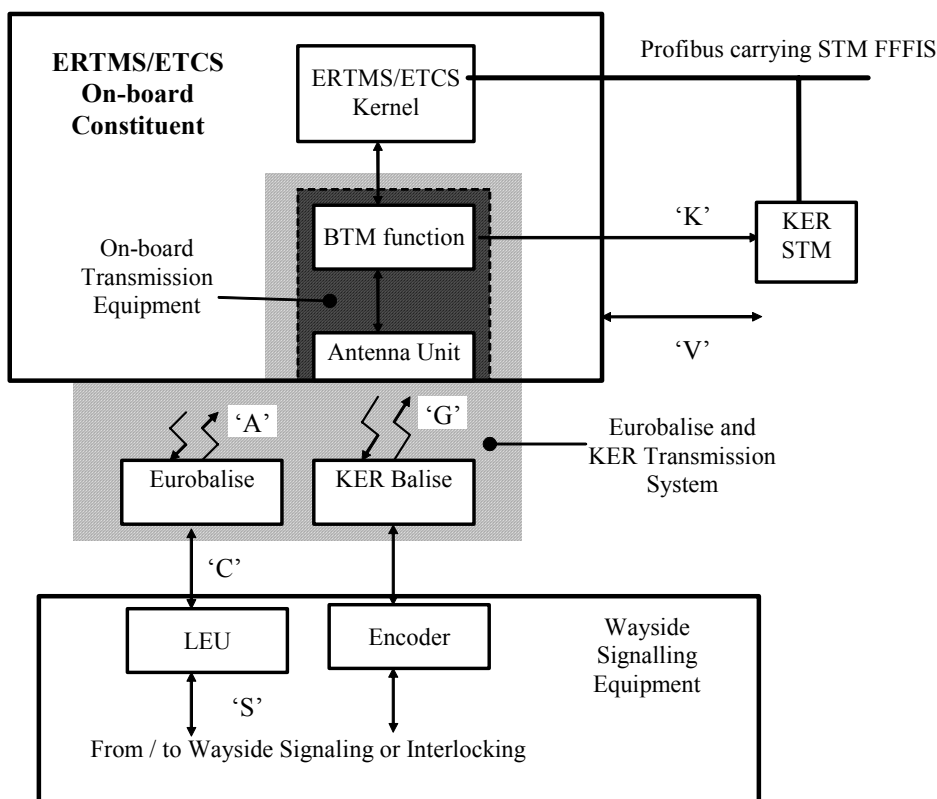

Figure 1: General Architecture

2 References

This specification incorporates, by dated or undated references, provisions from other publications. These references are cited at the appropriate places in the text, and the publications are listed hereafter. For dated references, subsequent amendments to, or revisions of, any of these publications apply to this specification only when incorporated herein by amendment or revision. For undated references, the latest edition of the publication referred to applies.

I. UNISIG Specifications:

- A. UNISIG SUBSET-036, FFFIS for Eurobalise
- B. UNISIG SUBSET-023, Glossary of UNISIG Terms and Abbreviations
- C. UNISIG SUBSET-100, Interface 'G' Specification
- D. UNISIG SUBSET-085, Test Specification for Eurobalise FFFIS
- E. UNISIG SUBSET-101, Interface 'K' Specification

II. International Standards:

- A. EIA 485, Standard for Electrical Characteristics of Generators and Receivers for Use in Balanced Digital Multipoint Systems, Issue April 1983
- B. EN 50155, Railway Applications, Electronic Equipment used on Rolling Stock, Issue August 2001

3 Terminology and Definitions

3.1 Acronyms and Abbreviations

In general, the acronyms and abbreviations of UNISIG SUBSET-101, UNISIG SUBSET-100, and of UNISIG SUBSET-023, apply. The following list of additional acronyms applies within this specification:

Acronym	Explanation
APT	Antenna Positioning Tool
CS	Current Sense
LTMS	Laboratory Test and Measurement System
LTOM	Laboratory Time and Odometer Module
RF	Radio Frequency
RSG	Reference Signal Generator
VSWR	Voltage Standing Wave Ratio

3.2 Definitions

In general, the definitions of UNISIG SUBSET-101, UNISIG SUBSET-100, and of UNISIG SUBSET-023, apply.

3.3 Influence of Tolerances

The requirements in the specification limits stated in UNISIG SUBSET-101 and UNISIG SUBSET-100 do not involve the error of the test equipment that is used in the test process, unless this is expressly written. This means that a maximum limit value shall be decreased, and a minimum limit value shall be increased with the applicable equipment error during test. Thus, the use of a very accurate test tool widens the allowed tolerances for the actual test object.

The numbers of digits, in which the specific parameter values are expressed, are not to be regarded as significant digits. The tolerances state the accuracy, and thus the significance of the digits. Thus, they (the expressed number of digits) do not imply a certain required accuracy or resolution. The required resolution and accuracy must be evaluated by other means. A general principle is that the accuracy/resolution of test tools should be in the order of 1 % (or possibly 5 %) of the specified tolerance range (if feasible), or better.

4 Tests of the On-board Transmission Equipment

4.1 Reference Test Configuration

4.1.1 General

In order to minimise the possible influence from the surrounding environment, there shall be a volume around the Antenna Unit and the Reference Loop under test that is free from metallic objects. The minimum extent of this volume is defined in Figure 2. This volume is also referred to as “free space condition”. The space below 0.4 m (but above 0.7 m) underneath the Reference Loop shall not contain any solid metal planes, and only a few metallic supports are allowed within 0.7 m underneath the Reference Loop.

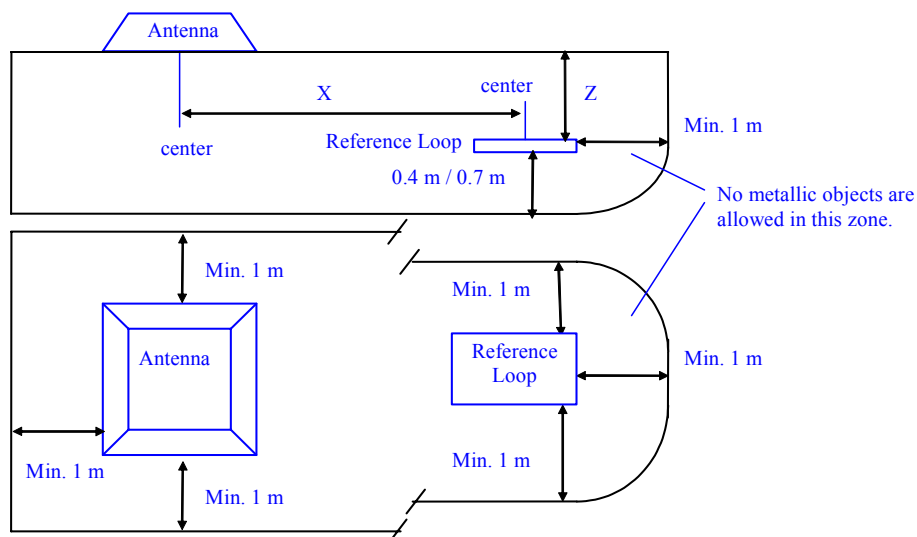

Figure 2: Definition of “free space” around the units under test

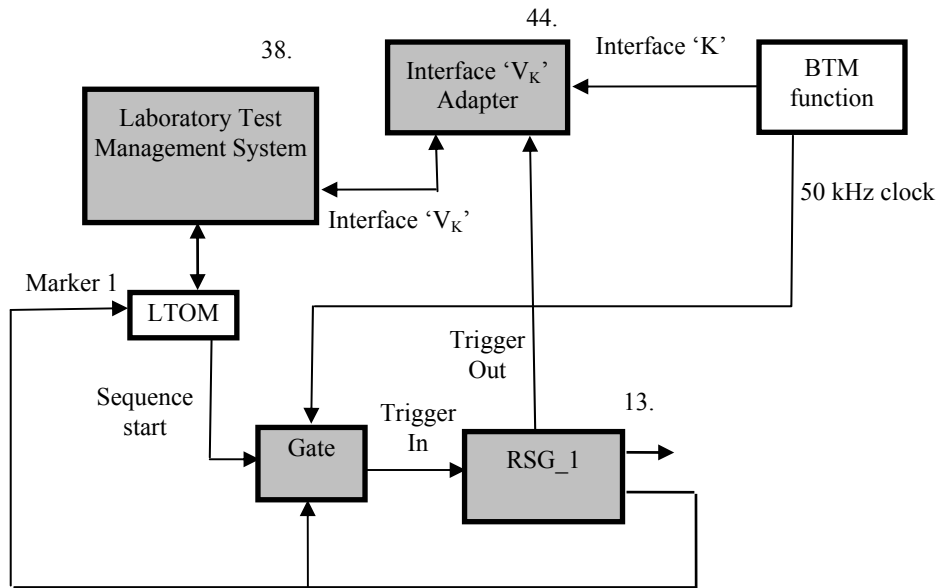

Figure 4: Specific triggering configuration

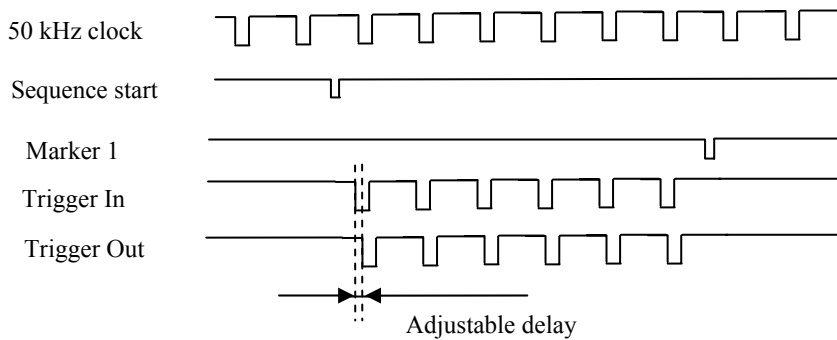

Figure 5: Triggering Timing Diagram

The RSG shall provide the possibility to adjust the “Trigger Out” such that it reflects the actual position of the expected ‘zero’ bit coming from the Balise (based on the actual modulation of the Tele-powering signal and the Up-link signal in the air gap). The principles for the required calibration are defined in section 4.1.7 on page 24.

4.1.3 Generic Test and Calibration Set-up Notes

The following aspects shall be respected for all test set-ups within this chapter (chapter 4). For some set-ups all aspects apply, but for others only some apply. The applicability is evident from the recommended test set-ups presented herein.

1. A spectrum analyser or similar equipment may substitute any power meter. However, this device shall be calibrated against a power meter prior to the test.
2. Unless otherwise stated herein, specific test tools are defined and detailed in UNISIG SUBSET-085.
3. It shall be verified that all harmonics are suppressed by at least 40 dB if power meters are used. Otherwise, sufficient filtering shall be performed.
4. All input and output ports of the Tests Antennas and Activation Antennas shall be equipped with suitable baluns (these are part of the defined devices). See UNISIG SUBSET-085.
5. The attenuators connected before and after the RF power amplifier shall be positioned as close as possible to the amplifier, and are used for ensuring good VSWR. The attenuator on the amplifier output is also used for protecting the amplifier from reflected power.
6. It is important that all RF cabling is of low loss double shielded type (e.g., RG 214). Furthermore, the cables shall be “de-bugged” using suitable ferrite clamps, evenly spaced along the cables, at distances less than 70 cm. The core material in the ferrite clamps shall be “Amidon 43” or equivalent.
7. Throughout this specification, ‘all zero’ sequences of amplitude modulation data shall be used unless explicitly otherwise specified.
8. RMS values are applicable unless otherwise explicitly stated. Integration time shall be selected in order to achieve sufficient measurement accuracy. Please observe that this is not applicable to for measurements of the ASK Up-link signal (see item 9 below).
9. The ASK Up-link signal shall be measured with an oscilloscope. After acquiring the actual waveform of a ‘zero’ bit, the definitions of UNISIG SUBSET-100 (section “Up-link Electrical Data”) shall be applied in order to determine the Up-link signal level.
10. Iron bars shall be at least 200 mm from metal objects like a concrete floor containing iron reinforcements.
11. The cable carrying the 27 MHz signal to the Test Antenna (see UNISIG SUBSET-085) shall be identical throughout the entire test process.
12. It is essential that the Reference Loops used during the tests fulfil the requirements of UNISIG SUBSET-085, and are characterised prior to testing.
13. Ferrite devices shall be used in order to reduce the RF field effect on the measurements. A balun basically consists of a ferrite core (see UNISIG SUBSET-085 for more details). A balun shall be positioned at the end of the cable, i.e., at the Reference Loop connector, unless otherwise explicitly stated.
14. All distances are in millimetres unless explicitly otherwise stated.
15. The attenuator (item 29) is used for ensuring a well defined 50 Ω source for driving the Reference Loop.
16. Please note that attenuation in the RF switches, balun, attenuator, and cabling shall be considered.

17. The requirements on the RF switches are that the frequency range is DC to several hundred MHz, and that the attenuation is less than approximately 0.2 dB at 30 MHz. At 2 MHz to 30 MHz, isolation and VSWR should be better than 50 dB and 1:1.05 respectively. Switching time shall be minimised in order to limit the overall test time. The switch shall be able to withstand a current of at least 2 A.
18. The attenuator (item 29) may optionally be replaced by one with lower attenuation during Cross-talk tests if this is required in order to achieve sufficient signal levels for obtaining reliable test results. In this case special precautions must be considered in order to characterise the actual Reference Loop load conditions.
19. It is important to synchronise the observation of the BTM function reporting with the simulation of the Balise passage.
20. Item 45 (the low pass filter) is used to filter out the 27 MHz power signal sent by the Reference Loop towards the Power Amplifier. The recommended performance of the filter is found in UNISIG SUBSET-085. The filter shall be connected directly at the output of the attenuator close to the Reference Loop.
21. Item 12 (the low pass filters) is used to filter out the 27 MHz signal sent by the Reference Loop towards the oscilloscope. The specifically recommended performance of the filter is found in UNISIG SUBSET-085. The filters shall be located directly at the Current Sense output of the balun.
22. The RSG should be programmed in order to issue a trigger pulse in correspondence to the centre of the dynamic up-link signal. This pulse triggers the oscilloscope to measure the Up-link signal level, and the LTOM to record the corresponding time and odometer data.
23. During the normal operation of the BTM, it needs to receive appropriate data from the LTOM (via Interface 'V₂'). Unless otherwise explicitly stated, a speed of 100 km/h applies.

4.1.4 Test Conditions

4.1.4.1 Nominal Conditions

4.1.4.1.1 General

The nominal conditions defined in this section apply to all measurements unless otherwise explicitly stated.

4.1.4.1.2 Climatic Conditions

Ambient temperature: 25 °C ±10 °C.

Relative humidity: 25 % to 75 %.

Atmospheric Pressure: 86 kPa to 106 kPa.

4.1.4.1.3 Metallic Objects and Debris

No metallic objects shall be present.

No debris shall be applied.

In order not to get any disturbance from the surrounding environment, there shall be a volume around the Antenna Unit and the Reference Loop that is free from metallic objects. The minimum extent of this volume is defined in 4.1.1 on page 14. This volume is also referred to as “free space condition”. The space below 0.4 m (but above 0.7 m) underneath the Reference Loop shall not contain any solid metal planes, and only a few metallic supports are allowed within 0.7 m underneath the Reference Loop.

4.1.4.1.4 Up-link signal Characteristics

The parameters of the 4.5 MHz ASK signal in the air gap shall be set to their nominal values as defined by UNISIG SUBSET-100.

- Carrier Frequency = 4.5 MHz ±20 kHz
- Amplitude jitter = less than ±0.1 dB

The Mean Data Rate is determined by the device under test.

The envelope of the pulse shall be approximately exponentially decreasing. The time from 90 % to 45 % of amplitude shall be $t_{50} = 3.8 \mu\text{s} \pm 0.1 \mu\text{s}$. See Figure 6 on page 20. The pulse is defined to start at 45 % of the peak amplitude. Momentary RMS is defined over one period of the nominal frequency of the signal itself.

The time t_{pudelay} is dependent on the Balise Type as defined in UNISIG SUBSET-100. The nominal values apply within a tolerance of ±50 ns.

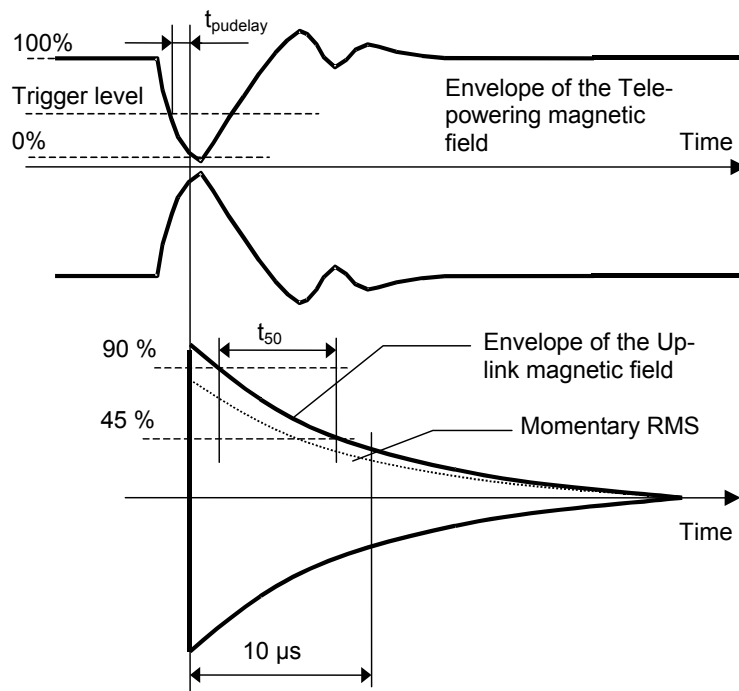

Figure 6: Definition of Up-link pulses

4.1.4.1.5 Tele-powering Characteristics

The 27 MHz Tele-powering signal shall be toggling Tele-powering.

4.1.4.1.6 Telegram Contents

The Reference Loop shall transmit an 'all zero' sequence.

4.1.4.1.7 Tilt, Pitch, and Yaw

Tilt, Pitch, and Yaw angles shall be set to 0 (zero).

4.1.4.2 Specific Conditions

4.1.4.2.1 Tilt, Pitch, and Yaw

According to UNISIG SUBSET-100, tilting shall be applied to both the Antenna Unit and the Reference Loop.

Therefore, tilt angles shall be set to worst case maximum angle according to Antenna Unit manufacturer specification and the maximum tilting of the Reference Loop to the extreme value defined in UNISIG SUBSET-100. Both the Antenna Unit and the Reference Loop are subject to tilting, and the worst case combination applies.

According to UNISIG SUBSET-100, pitching shall be applied to both the Antenna Unit and the Reference Loop.

Therefore, pitch angles shall be set as defined below. Both the Antenna Unit and the Reference Loop are subject to pitching, and the worst case combination applies.

- Reference Loop pitch angle according to the extreme value defined in UNISIG SUBSET-100.
- Antenna Unit pitch angle at maximum according to supplier specification.

The influence of yaw angles should not be tested, because no major influence is anticipated.

4.1.4.2.2 Debris

Test conditions, and the design and utilisation of the debris box, are defined by UNISIG SUBSET-085.

For the Reference Loop, the following conditions apply:

- Salt Water
- Clear Water
- Iron Ore (Magnetite)

The specific amount of debris applicable during testing is defined in UNISIG SUBSET-100.

4.1.5 Test Tools and Procedures

The following list summarises the herein-defined On-board Transmission Equipment tests:

1. Electrical data
2. Data transmission
3. Timing requirements
4. Functional data
5. Link check functionality
6. Transmission and bit stream requirements:
 - 6.1. Evaluation of radiation pattern
 - 6.2. Transmission tests
 - 6.3. Electrical Tele-powering characteristics
 - 6.4. Maximum flux level
 - 6.5. Up-link characteristics
 - 6.6. Cross-talk immunity
 - 6.7. Cross-talk immunity with cables
 - 6.8. Balise Detect ability supervision

The following tools are anticipated for the On-board Transmission Equipment tests:

- Test Management System, used for co-ordinating the measurements, controlling the other tools of the test set-up, and for logging and reporting the test results
- Antenna Positioning Tool
- Reference Loops (Standard or Reduced Size type) equipped with baluns
- Test and Activation Antennas
- Signal Generators
- RF instruments and accessories of general use
- Reference Units for debris and cables
- Interface adapters

4.1.6 Determination of ASK Up-link Signal Level

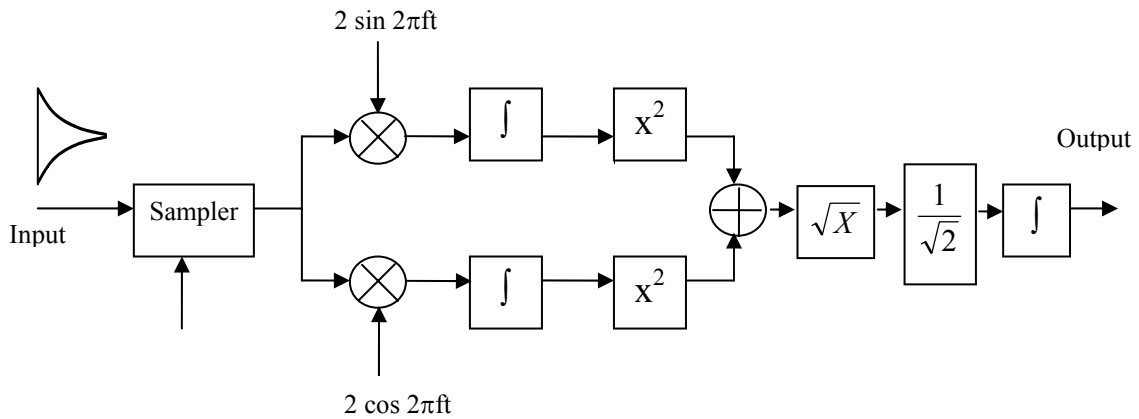

Figure 7: Determination of ASK Up-link Signal Level

The frequency of the sine and cosine signals in the multiplication process shall be close to 4.35 MHz.

The first integration (after the multiplication process) shall provide integration over one period of the 4.35 MHz sine signal.

The last integration shall provide integration over 10 us starting such that the output result is maximised.

The process above may be performed such that the input signal (covering at least one complete 'zero' bit) is in real time sampled at a sampling rate of 200 Msamples/s, and the resulting samples are stored in a file for subsequent off-line software processing. Sampling shall start at least 200 ns before the start of the ASK bit in order ensure capturing of the entire bit.

For simplicity, select the frequency of the sine and cosine signals in the multiplication process to $200 \text{ MHz}/46 = 4.3478 \text{ MHz}$ (which is close enough to 4.35 MHz). This means that 46 samples are obtained over one period of the modulation signal.

The sampled input signal should be multiplied sample by sample by a discrete synthetically produced sine and cosine signal with the peak amplitude 2 in order to maintain the scaling of the input signal. The output result from the multiplication process is two vectors of the same length as the input signal vector.

The succeeding integration (in each of the two branches) shall be performed such that 46 consecutive samples are summed in a sliding 46 bit long window. Please observe that the result of each summation shall be divided by 46 to maintain the scaling. The result is two vectors with the length of the input vector minus 45 samples (the first 45 sums can not be used since the sliding window was not yet filled up).

Thereafter, the square of each result of the output vectors from the integration shall be calculated, and the obtained result from each of the two branches shall be summed sample by sample. The result is one vector with the same length as after the integration process.

The next step is to calculate the square root out of each sample in the vector. This is followed by division by $\sqrt{2}$ in order to convert peak scale to RMS scale. The result of this is one vector with the same length as after the integration process.

The final step is to perform integration over 10 us. The method is that 2000 consecutive samples are summed in a sliding 2000 bit long window. Please observe that the result of each summation shall be divided by 2000 to maintain the scaling. The output result is obtained in the position of the sliding window where the resulting sum is maximised. In case an on-line process is required, the position of the integration window can be regarded deterministic after it has once been determined.

4.1.7 Calibration of Up-link data generation

The position of the trigger pulse sent to the Interface 'V_K' adapter and the Up-link signal generation shall be correctly positioned with respect to the modulation pulses of the Tele-powering signal.

Use the test set-up defined in Figure 3 on page 15 and Figure 4 on page 16.

1. Position the Reference Loop at [X = 200, Y = 200, Z = 460] relative to the reference position of the On-board antenna.
2. Switch on the Tele-powering signal from the BTM.
3. Set the RF switches such that the oscilloscope shows the Tele-powering signal received by the Reference Loop.
4. Connect the other channel of the oscilloscope to the "Trigger Out" from the RSG_1.
5. Start a suitable sequence from the LTMS (such that the "sequence start" pulse is obtained).
6. Measure the time between the 90 % level of the falling edge of the Tele-powering modulation pulse and the negative edge of the "Trigger Out" pulse from the RSG_1.
7. Adjust a delay within the RSG_1 such that the time measured in step 6 corresponds to the desired value of $t_{pudelay}$.
8. Set the RF switches such that the oscilloscope shows the Up-link signal (as measured in the Current Sense output of the Current Sense Balun).
9. Measure the time between the 45 % level of the rising edge of the Up-link signal 'zero' bit and the negative edge of the "Trigger Out" pulse from the RSG_1.
10. Adjust a delay within the RSG_1 such that the time measured in step 9 is zero within the accuracy defined in section E3.3 on page 135.

4.2 Laboratory Tests, Alternative 1 Interface

4.2.1 Electrical Data

4.2.1.1 General Description, Electrical Data

This section outlines the tests needed for ensuring that the electrical data for Interface 'K' is fulfilled.

Since it is likely that commercially available transmitter circuits are used, it is in such a case sufficient to ensure (show guarantees) that the actual device fulfils the applicable standard. Specifically developed transmitter circuits must be fully characterised in order to show compliance with the applicable standard.

The principle above also applies to ensuring the defined isolation requirements.

Since the type of cable and the cable length is not harmonised, the requirements defined by the standard shall be fulfilled at the input of the receiver(s).

4.2.1.2 Conditions, Electrical Data

The maximum cable length specified by the manufacturer shall be considered.

The maximum amount of loading receivers and (non active) transmitters shall be considered. See definitions in UNISIG SUBSET-101.

4.2.1.3 Acceptance Criteria, Electrical Data

- a. The limits defined by the RS 485 standard shall be fulfilled.
- b. The isolation requirements defined by the EN 50155 standard shall be fulfilled.

4.2.2 Data Transmission

4.2.2.1 General Description, Data Transmission

This section defines the test procedure for verifying the data transmission. The test procedure includes verification of the following properties:

- Presence of start and stop bits
- Correctness of Bi Phase Level (BPL) coding

The order of the transmitted information is implicitly verified during the tests of section 4.2.4 on page 28.

4.2.2.2 Test Pattern, Data Transmission

The RSG shall be programmed such that a repetitive 00001110101 ASK bit pattern is continuously transmitted through the air gap (Interface 'G').

4.2.2.3 Test Procedure, Data Transmission

1. Position the antenna such that the manufacturer dependent nominal vertical distance is obtained with respect to the Reference Loop, and that $X=0$ and $Y=0$ with respect to the Reference Loop.
2. Adjust the output level from the RSG such that an Up-link current of $I_{u1} + 3$ dB is obtained. Please observe that the Up-link current must be modulated as defined in Figure 8 on page 36.
3. Temporarily connect the oscilloscope to Interface 'K'. Please observe that a floating measurement shall be performed (e.g., using two channels and performing a differential measurement). The oscilloscope should be triggered from the output of the RSG.
4. Record the resulting transmission of at least one repetition of the defined pattern.
5. Verify the existence of start and stop bits.
6. Verify the correctness of the Bi Phase Level (BPL) coding.

4.2.2.4 Acceptance Criteria, Data Transmission

- a. The test shall verify the existence of start and stop bits as specified in UNISIG SUBSET-101.
- b. The test shall verify that the Bi Phase Level (BPL) coding is in accordance with UNISIG SUBSET-101.

4.2.3 Timing Requirements

4.2.3.1 General Description, Timing Requirements

This section defines the test procedure for verifying the timing requirements. The test procedure includes verification of the following properties:

- Correctness of 50 kHz ASK bit data rate
- Correctness of phase position between various channels (if more than one is implemented)
- Correctness of the Bi Phase Level (BPL) clock
- Propagation delay from Interface 'G' to Interface 'K'

4.2.3.2 Test Pattern, Timing Requirements

The RSG shall be programmed such that a repeated 40 ASK bit pattern starting with 8 consecutive 'zeros' followed by 8 consecutive 'ones', and finally followed by toggling 'zeros' and 'ones' up to the end of the of the pattern is continuously transmitted through the air gap (Interface 'G').

4.2.3.3 Test Procedure, Timing Requirements

1. Position the antenna such that the manufacturer dependent nominal vertical distance is obtained with respect to the Reference Loop, and that $X=0$ and $Y=0$ with respect to the Reference Loop.
2. Adjust the output level from the RSG such that an Up-link current of I_{u2} is obtained. Please observe that the Up-link current must be modulated as defined in Figure 8 on page 36.
3. Temporarily connect the oscilloscope to Interface 'K'. Please observe that a floating measurement shall be performed (e.g., using two channels and performing a differential measurement). The oscilloscope should be triggered from the output of the RSG.
4. Record the resulting transmission of at least one full bit pattern repetition in the air gap.
5. Evaluate the 50 kHz ASK bit data rate.
6. In case more than one channel is implemented, measure the phase position between various channels.
7. Evaluate the Bi Phase Level (BPL) clock performance (jitter).
8. Evaluate the propagation delay between the air gap signal and the data transmitted through Interface 'K'.
9. Record the resulting transmission of at least 500 'zero' bits and one 'one' bits in the air gap, and evaluate the number of stop bits for all ASK bits.

4.2.3.4 Acceptance Criteria, Timing Requirements

- a. The ASK bit data rate shall be 50 kbits/s within the tolerance specified in UNISIG SUBSET-100.
- b. The phase difference between the various channels (if more than one is implemented) shall be less than what is specified in UNISIG SUBSET-101.
- c. The jitter on the Bi Phase Level (BPL) clock shall be less than defined in UNISIG SUBSET-101.
- d. The propagation delay shall be less than what is specified in UNISIG SUBSET-101.
- e. The number of stop bits shall be 24 to 26.

Data shall not be evaluated in case a forced link test occurs.

4.2.4 Functional Data

4.2.4.1 General Description, Functional Data

This section defines the test procedure for verifying the correct transmission of data from a functional perspective. The test procedure includes verification of the following properties:

- Transmission of 'Data for Balise Detection' (BD)
- Transmission of 'Data for Telegram Decoding' (TD)
- Transmission of 'ERTMS Unavailability' upon switching Tele-powering off (EU)
- Transmission of 'Eurobalise Reception' upon reception of Eurobalises (EB)
- Transmission of 'Link Test Data' (LT)
- Transmission of 'Signal Strength Data' (S)
- Transmission of 'Antenna/BTM ID Data' (A)
- Transmission of 'Link ID Data' (L)
- Transmission of 'Bit Counter' (B)
- Correctness of CRC generation

In case multiple channels are implemented, the requirements related to diversified data defined in UNISIG SUBSET-101 will also be verified from a transmitter perspective. Finally, simulation of a permanently failing BTM functionality is also simulated (including absence of BPL coding).

4.2.4.2 Test Patterns, Functional Data

4.2.4.2.1 General

In general, the RSG shall be programmed such that a 00001110101 ASK bit pattern is continuously transmitted through the air gap (Interface 'G').

4.2.4.2.2 Specific FSK pattern

A specific pattern that is to be transmitted is a valid Eurobalise FSK Up-link signal. The Up-link signal shall be set to the nominal conditions defined in UNISIG SUBSET-085, and carry the defined Telegram 17.

4.2.4.3 Test Procedure, Functional Data

1. Position the antenna such that the manufacturer dependent nominal vertical distance is obtained with respect to the Reference Loop, and that $X=0$ and $Y=0$ with respect to the Reference Loop.
2. Adjust the output level from the RSG such that an Up-link current of I_{u0} -20 dB is obtained. Please observe that the Up-link current must be modulated as defined in Figure 8 on page 36. Please also observe that the current measured by the oscilloscope needs to be compensated for the B-factor of the Reference Loop (i.e., the measured target current shall be the desired Reference Loop current divided by B). Please observe also the definitions of UNISIG SUBSET-100 for the definition of the signal level.
3. Record, via Interface ' V_K ', the resulting transmission of at least one 'zero' bit and one 'one' bit in the air gap. The recording shall be synchronised with the transmission of the air gap signal, and data shall not be evaluated in the potential presence of a link check.
4. Increase the output level from the RSG such that the Up-link current is increased by 3 dB.
5. Record, via Interface ' V_K ', the resulting transmission of at least one 'zero' bit and one 'one' bit in the air gap. The recording shall be synchronised with the transmission of the air gap signal, and data shall not be evaluated in the potential presence of a link check.
6. Repeat steps 4 and 5 until the output level from the RSG is such that an Up-link current of I_{u3} is obtained.
7. Adjust the output level from the RSG such that an ASK Up-link current of I_{u2} is obtained. Please observe that the Up-link current must be modulated as defined in Figure 8 on page 36.
8. Temporarily command Tele-powering off instead of Tele-powering on.
9. Record, via Interface ' V_K ', the resulting transmission of at least one 'zero' bit and one 'one' bit in the air gap. The recording shall be synchronised with the transmission of the air gap signal.
10. Temporarily transmit the FSK Up-link sequence defined in section 4.2.4.2.2 on page 28.
11. Record, via Interface ' V_K ', the resulting transmission over a period of time of 2 ms. The recording shall be synchronised with the transmission of the air gap signal.
12. Temporarily stop transmitting any Up-link signal via the air gap.
13. Record, via Interface ' V_K ', the resulting transmission over a period of time exceeding 500 ms.
14. For equipment making judgement on permanent errors, temporarily introduce a permanent error in the On-board Transmission Function.
15. Record, via Interface ' V_K ', the resulting transmission over a period of time exceeding 500 ms. The recording shall be synchronised with the transmission of the air gap signal.
16. Ensure that the BTM functionality is reset to proper operation.
17. In case multiple antenna/BTM functions are implemented, steps 2 through 13 shall be repeated for all possibilities.
18. In case more than one transmission channel is implemented (due to either redundancy or safety), steps 2 through 13 shall be repeated for all channels.

4.2.4.4 Acceptance Criteria, Functional Data

For each of the acquisitions performed in steps 3 and 5, it shall be verified that:

- a. 'Data for Balise Detection' indicates 'zero' synchronised with 'zero' in the air gap signal when the signal is above the fix threshold, and 'one' when the signal is below the fix threshold. 'Data for Balise Detection' indicates 'one' synchronised with 'one' the air gap signal when the signal is below the fix threshold, and also 'one' when the signal is above the fix threshold. The exception is that also indication of 'zero' is acceptable at very strong input signals provided that Data for Telegram Decoding is transmitted.
- b. 'Data for Telegram Decoding' indicates either 'zero' or 'one' synchronised with 'zero' in the air gap signal when the signal is below the fix threshold. 'Data for Telegram Decoding' indicates 'zero' synchronised with 'zero' in the air gap signal when the signal is above the fix threshold. 'Data for Telegram Decoding' always indicates 'one' synchronised with 'one' in the air gap signal regardless of signal level. If this optional data is not explicitly provided, the contents shall be identical to 'Data for Balise Detection'.
- c. 'ERTMS Unavailability' is set to logical 'zero'.
- d. 'Eurobalise Reception' is set to logical 'zero'.
- e. 'Link Test Data' is set to logical 'zero'.
- f. In case 'Signal Strength Data' is not provided, the corresponding four data bits shall be set to logical 'zero'. In case Signal Strength Data is provided, the corresponding four data bits shall indicate a company specific binary value in the range from 0001 to 1111. Successive readings shall be either equal or higher when the output level from the RSG is successively increased. It is acceptable with a maximum fluctuation of one LSB. The regions for transition from one value to another may be manufacturer specific.
- g. 'Antenna/BTM ID Data' is according to the intended antenna/BTM function. Rare occurrence of corruption is acceptable as long as this does not violate the specified error rate.
- h. Transmission of 'Link ID Data' is according to the intended channel. Rare occurrence of corruption is acceptable as long as this does not violate the specified error rate.
- i. The 'Bit Counter' is increasing by one (modulo 8) for each ASK bit.
- j. CRC is correct. Rare occurrence of corruption is acceptable as long as this does not violate the specified error rate.

For the acquisitions performed in step 9, it shall be verified that:

- k. 'ERTMS Unavailability' is set to logical 'one'.

For the acquisition performed in step 11, it shall be verified that:

- l. 'Eurobalise Reception' is set to logical 'one' no later than the in UNISIG SUBSET-101 specified time after the start of the transmission of the specific pattern via Interface 'V_K'.

For the acquisition performed in step 13, it shall be verified that:

- m. Link check patterns are transmitted in accordance with the requirements of UNISIG SUBSET-101.

For the acquisition performed in step 15, it shall be verified that:

- n. The interface 'K' channel activity is terminated (including no BPL coding) after the introduction of the failure condition.

Specifically for step 18 (if applicable), aspects on diversified data shall be considered. See requirements in UNISIG SUBSET-101.

4.2.5 Link Check Functionality

4.2.5.1 General Description, Link Check Functionality

This section defines the test procedure for verifying the correct transmission of signals used for on-line supervision of the Interface 'K' link. The test procedure includes verification of the following properties:

- Time between transmissions of link check patterns
- Correctness of link check pattern
- Transmission of 'Link Test Data' upon progressing transmission tests
- Blocking of link checks during reception of Balise data

4.2.5.2 Test Pattern, Link Check Functionality

In the beginning of the test (up to step 3 in section 4.2.5.3), there shall be no transmission of Up-link signals through the air gap.

In the second phase of the test (from step 4 to step 5), the RSG shall be programmed such that a repetitive ASK bit pattern including the maximum number of allowed consecutive 'ones' (see UNISIG SUBSET-101) is continuously transmitted through the air gap (Interface 'G').

In the third phase of the test (from step 6 to step 7), the RSG shall be programmed such that the Up-link signal pattern constitutes Eurobalise data as defined in section 4.2.4.2.2 on page 28, which is continuously transmitted through the air gap (Interface 'G').

4.2.5.3 Test Procedure, Link Check Functionality

1. Without transmitting any Up-link signal, record the resulting transmission via Interface 'V_K' for a period of time exceeding 2 s.
2. Calculate the time between succeeding link checks.
3. Position the antenna such that the nominal vertical distance is obtained with respect to the Reference Loop, and that X=0 and Y=0 with respect to the Reference Loop.
4. Start transmitting the ASK Up-link signal, and adjust the output level from the RSG such that an Up-link current of I_{u1} is obtained. Please observe that the Up-link current must be modulated as defined in Figure 8 on page 36. Please also observe that the current measured by the oscilloscope needs to be compensated for the B-factor of the Reference Loop (i.e., the measured target current shall be the desired Reference Loop current divided by B). Please observe also the definitions of UNISIG SUBSET-100 for the definition of the signal level.
5. Record the resulting transmission via Interface 'V_K' for a period of time sufficient to cover a period of time exceeding 2 s.
6. Switch over to transmitting the FSK Up-link signal, and adjust the output level from the RSG such that an Up-link current of I_{u1} is obtained.
7. Record the resulting transmission via Interface 'V_K' for a period of time sufficient to cover a period of time exceeding 2 s.
8. In case multiple antenna/BTM functions are implemented, steps 1 through 7 shall be repeated for all possibilities.
9. In case more than one transmission channel is implemented (due to either redundancy or safety), steps 1 through 7 shall be repeated for all channels.

4.2.5.4 Acceptance Criteria, Link Check Functionality

For the acquisition performed up to step 3, it shall be verified that the link test includes the four mandatory ASK bits defined in UNISIG SUBSET-101. In case the optional ASK bits (as defined in UNISIG SUBSET-101) are transmitted, it shall be verified that no more than 15 additional bits are transmitted. It shall also be verified that the Link Test data is transmitted consistently with the link test pattern.

For the acquisition performed up to step 3, it shall be verified that there is at least one approved link test within the defined sliding 250 ms time interval.

For the acquisition performed in step 5, it shall be verified that the following is transmitted for a period of time not exceeding 1 s:

- a. 'Data for Balise Detection' indicates 'zero' synchronised with 'zero' in the air gap signal. 'Data for Balise Detection' indicates 'one' synchronised with 'one' in the air gap signal.
- b. 'Data for Telegram Decoding' shall be identical to 'Data for Balise Detection'. If this optional data is not explicitly provided, the contents shall also be identical to 'Data for Balise Detection'.
- c. 'ERTMS Unavailability' is set to logical 'zero'.
- d. 'Eurobalise Reception' is set to logical 'zero'.
- e. 'Link Test Data' is set to logical 'zero'.
- f. In case 'Signal Strength Data' is not provided, the corresponding four data bits shall be set to logical 'zero'. In case 'Signal Strength Data' is provided, the corresponding four data bits shall represent relevant data for the selected Up-link signal level.
- g. 'Antenna/BTM ID Data' is according to the intended antenna/BTM function. Rare occurrence of corruption is acceptable as long as this does not violate the specified error rate.
- h. Transmission of 'Link ID Data' is according to the intended channel. Rare occurrence of corruption is acceptable as long as this does not violate the specified error rate.
- i. The 'Bit Counter' is increasing by one (modulo 8) for each ASK bit.
- j. CRC is correct. Rare occurrence of corruption is acceptable as long as this does not violate the specified bit error rate.

After a period of time greater than 0.5 s but not exceeding 1 s, it shall be verified that a link test is transmitted also in the presence of transmission of ASK Up-link data.

For the acquisition performed in step 7, it shall be verified that the following is transmitted for a period of time not exceeding 1 s:

- k. 'Data for Balise Detection' indicates an all 'zero' pattern.
- l. 'Data for Telegram Decoding' indicates an all 'zero' pattern.
- m. 'ERTMS Unavailability' is set to logical 'zero'.
- n. 'Eurobalise Reception' is set to logical 'one'.
- o. 'Link Test Data' is set to logical 'zero'.
- p. 'Tele-powering Data' is set to logical 'one'.
- q. In case 'Signal Strength Data' is not provided, the corresponding four data bits shall be set to logical 'zero'. In case 'Signal Strength Data' is provided, the corresponding four data bits shall represent relevant data for the selected Up-link signal level.
- r. 'Antenna/BTM ID Data' is according to the intended antenna/BTM function. Rare occurrence of corruption is acceptable as long as this does not violate the specified error rate.
- s. Transmission of 'Link ID Data' is according to the intended channel. Rare occurrence of corruption is acceptable as long as this does not violate the specified error rate.
- t. The 'Bit Counter' is increasing by one (modulo 8) for each ASK bit.
- u. CRC is correct. Rare occurrence of corruption is acceptable as long as this does not violate the specified bit error rate.

After a period of time greater than 0.5 s but not exceeding 1 s, it shall be verified that a link test is transmitted also in the presence of transmission of FSK Up-link data.

4.2.6 Verification of Transmission and Bit Stream Requirements

4.2.6.1 General Description, Transmission and Bit Stream Requirements

This section (4.2.6) defines test procedures for Antenna Unit and BTM function tests. The test procedures include the following steps with partially different test set-ups and under various test conditions:

- Characterisation of radiation pattern and creation of signal pattern for dynamic tests
- Transmission tests
- Tele-powering characteristics tests and test of maximum flux level
- Up-link characteristics tests
- Cross-talk tests

Each Antenna Unit - BTM function combination shall be tested with the different Reference Loops. For the purpose of the Reduced Size Reference Loop, only transversal mounting orientation shall apply.

Reference Loop currents and the flux values shall be in accordance with the input-to output characteristic definition of UNISIG SUBSET-100. Please observe that the Up-link current measured by the oscilloscope needs to be compensated for the B-factor of the Reference Loop (i.e., the measured target current shall be the desired Reference Loop current divided by B). Please observe also the definitions of UNISIG SUBSET-100 for the definition of the signal level.

See also specific notes included in section 4.1.3 on page 17.

4.2.6.2 Evaluation of Radiation Pattern

4.2.6.2.1 General Description, Evaluation of Radiation Pattern

The purpose of this test is to find the weakest possible Balise signal and activation flux, during static conditions, where the Antenna Unit - BTM function combination has the ability to enable detection and decoding of the Balise for static geometrical points in the region above the Reference Loop (i.e., exploring the behaviour of the BTM function threshold V_{th} , and the Tele-powering flux). It shall also provide information on side lobe characteristics. The results from this test shall be used as input for creating the signal pattern for a simulated dynamic Balise passage as defined in section 4.2.6.3 on page 40, and used during the applicable tests of this document.

The procedure includes two steps. One is to measure the actual Tele-powering flux through the Reference Loop. The other is to determine the required Up-link current through the Reference Loop corresponding to the BTM function threshold (V_{th}). This corresponding current is denominated I_{th} . Tele-powering and Up-link characterisation are performed in two different phases (please observe that the measurement accuracy shall be maintained in the presence of 27 MHz Tele-powering signal when performing Up-link signal measurements).

During Tele-powering measurements, the actual flux ϕ through the Reference Loop is measured.

During Up-link checking, the Reference Loop shall be connected to a signal generator generating an ASK Up-link signal that simulates a representative Balise passage (see Figure 8 below), and carrying a sequence as defined below with a peak current level stepwise altered in order to reach I_{th} (as described below). The BTM function output response shall be observed via Interface 'V_K'. The BTM function is set in normal operational mode.

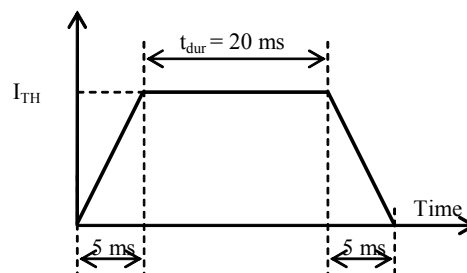

Figure 8: Up-link signal

The odometer input signal shall be selected such that the flat part of the sequence according to Figure 8 above corresponds to approximately 0.5 m at a speed of 100 km/h (the entire sequence from start of rising edge to end of falling edge corresponds to approximately 0.75 m).

The transmitted Up-link sequence shall in general be a pattern that is an “all zero” sequence, but for the so-called reference position, $[X = 0, Y = 0, Z = \text{maximum height}]$, it shall be evaluated if there are significant differences (more than 0.5 dB) in the evaluated threshold when applying also the repetitive sequences:

- 010101010101010101010101010101010101.....
- 11111101111111011111101111110.....

In case there are significant differences, also the worst case condition in terms of consecutive ‘ones’ for the related coding strategies should be considered. If significant differences are observed, then the thresholds evaluated with an “all zero” sequence shall be adjusted according to the evaluation. The highest possible corrected threshold (with the worst case sequence) shall be used for sensitivity oriented tests, and the lowest possible corrected threshold shall be used for cross-talk oriented tests.

During Up-link checking, a start value of I_{u1} through the Reference Loop shall be selected. Thereafter, the current level is either increased or decreased in steps until the BTM function threshold is reached. For increased current levels, steps of 0.2 dB are applicable up to $I_{u1} + 7$ dB, thereafter steps of 0.5 dB apply up to a maximum current level of $I_{u1} + 24$ dB. For decreasing current levels, steps of 0.5 dB apply down to the level I_{th} . Please observe that potential hysteresis phenomena shall be evaluated and considered. In case of hysteresis, I_{th} shall always be determined for increasing current levels.

An 'all zero' data sequence shall be used during this process (except for in the reference position, see above). The criterion for having reached the receiver threshold is that it is verified that at least 90 % of the received bits are 'zeros'. Both 'Data for Balise Detection' and 'Data for Telegram Decoding' shall be evaluated.

Actual Tele powering flux ϕ , and the threshold current I_{th} are recorded for each single geometrical test point defined in chapter A1 of Annex A on page 109. This procedure shall be repeated for all the test conditions defined in section 4.1.4 on page 19 and limited by the test matrices of chapters A3 and A4 in Annex A on pages 111 and 112 respectively. It is important that the position [$X = 0$, $Y = 0$, $Z = \text{maximum height}$] is explored, because this forms the reference for the calculations of section 4.2.6.3 on page 40. The threshold current for this position will be denominated I_{THREF} .

4.2.6.2.2 Test Procedure, Evaluation of Radiation Pattern

The test set-up in accordance with section 4.1.2 on page 15 applies.

1. Position the Antenna Unit in the geometrical test point [$X = 0, Y = 0, Z = \text{maximum height}$], and select nominal test conditions defined by section 4.1.4.1 on page 19.
2. Set the RF switches in positions P2 and P3 respectively (thus connecting power meter 2).
3. Command the BTM function to its normal operational mode regarding toggling Tele-powering, or to any other mode equivalent to this (from the point of view of the Up-link diagram evaluation).
4. Record the value of power meter 2.
5. Repeat step 4 for all remaining geometrical test points defined by chapter A1 on page 109 and chapter A3 on page 111.
6. Calculate and record the flux through the Reference Loop using the following equation:

$$\Phi = \frac{B \cdot \sqrt{50 \cdot P_{PM2}} \cdot \left(\frac{|50 + Z_{loop}|}{50} \right)}{2 \cdot \pi \cdot f_{27}}$$

where: P_{PM2} is power recorded by power meter 2
 B is the Reference Loop transfer matching ratio
 Z_{loop} is the actual impedance of the Reference Loop in the absence of any antenna
 f_{27} is the Tele-powering frequency (27.095 MHz)

Please observe that the attenuation and impedance of the RF switch, the attenuator, and the current sense balun have to be considered (characterised prior to testing). This is not considered in the equation above.

7. Set the RF switch in position P1 (thus enabling generation of Up-link signals).
8. Set the arbitrary generator to generate an Up-link signal in accordance with Figure 8 on page 36 and section 4.1.4.1.4 on page 19. The initial current setting shall be the minimum controllable current (in the order of 1 mA). The current is measured by the oscilloscope, and the related transfer response of the Current Sense balun is in accordance with UNISIG SUBSET-085. Please observe that the current measured by the oscilloscope needs to be compensated for the B-factor of the Reference Loop (i.e., the measured target current shall be the desired Reference Loop current divided by B). Please observe also the definitions of UNISIG SUBSET-100 for the definition of the signal level. Set the time and odometer information to comply with a speed of 100 km/h.
9. Position the Antenna Unit in the geometrical test point [$X = 0, Y = 0, Z = \text{maximum height}$].
10. Record the output from the BTM function (via Interface 'V_K'), and determine whether the Up-link signal was above or below the BTM function threshold (V_{th}). That is reception of at least 90 % of the expected amount of 'zeros'. Please observe the requirement in section 4.2.6.2.1 on page 36 regarding measurements with different patterns in the reference position (only).
11. In case that the signal was above the threshold, gradually decrease the current level in steps as defined by section 4.2.6.2.1 on page 36 until the signal drops below the threshold. In case the signal was below the threshold, gradually increase the current level in steps as defined by section 4.2.6.2.1 on page 36 until the signal exceeds the threshold. Record the actual threshold value I_{th} . Please observe the note regarding hysteresis in section 4.2.6.2.1 (this may always require determination of I_{th} for increasing current levels).

12. Repeat steps 10 and 11 for all remaining geometrical test points defined by chapter A1 on page 109 and chapter A3 on page 111. In order to speed up the procedure, the iterative evaluation of the new threshold value I_{th} can be done starting from an optimised value based on the values evaluated for the previous nearby positions.
13. Repeat steps 1 through 12 for all specific test conditions defined by section 4.1.4.2 on page 21 and chapter A3 on page 111. Please observe that “nominal conditions” of step 1 is substituted by the relevant “specific condition” for each subsequent pass.
14. Repeat steps 1 through 4 and 7 through 11 at the temperature extremes, and evaluate possible change of performance. Potential change of performance shall be considered in calculations of section 4.2.6.3 on page 40.

It must be verified that reliable Up-link measurements can be performed in the presence of the applicable 27 MHz Tele-powering signal.

4.2.6.3 Creation of Signal Pattern for Dynamic Tests

4.2.6.3.1 General Description, Creation of Signal Pattern for Dynamic Tests

The aim is to create a time varying 4.5 MHz current through the Reference Loop that simulates a Balise passage without any physical movements of the equipment. In other words, it is a time dependent modulation of the Up-link signal (in addition to the normal modulation forming the ASK signal). During the following applicable tests of this document, the Reference Loop will be positioned in $[X = 0, Y = 0, Z = \text{maximum height}]$. This is the geometrical reference point.

The recorded Tele-powering flux level (ϕ in Figure 9 on page 42) shall be used for determining the response from two different worst case Balises (I_{LOW} and I_{HIGH} in Figure 9 on page 42), utilising the lower and upper limits of the transfer response curve defined by UNISIG SUBSET-100.

Thereafter, considering data (I_{th}) obtained during the radiation pattern tests defined by section 4.2.6.2 on page 36, a signal pattern simulating a Balise passage shall be calculated. For all geometrical positions (and all applicable test conditions) the actual current required for passing the BTM function threshold (I_{th}) shall be compared with I_{THREF} (see below). A special geometrical test point is $[X = 0, Y = 0, Z = \text{maximum height}]$ that serves as reference. The corresponding threshold value is denominated I_{THREF} . Please observe the potential correction required in case there are significant differences for different test patterns.

The ϕ and I_{th} patterns recorded along the X-axis for each lateral and vertical displacement, and for each Balise behaviour (illustrated in Figure 9 on page 42), will have to be stored in separate files in order to use them for simulating dynamic signals of Balise passages.

The signal pattern to be calculated (and simulated) is the Up-link signal current through the Reference Loop, constituting the sum of the weakest or strongest possible Balise and the difference between I_{th} and I_{THREF} (considering the correct sign). Furthermore, realistic start-up behaviour of the Balise shall be simulated (including a certain delay time T_{bal}) for the weakest possible Balise. The latter includes that the Balise is inactive until a flux level of ϕ_{d1} is reached, and that a delay time T_{bal} according to UNISIG SUBSET-100 is applicable. Each simulated Balise passage shall be normalised with respect to I_{THREF} .

In order to visualise that data has to be collected once only, followed by proper scaling to simulate a desired velocity, the example of signal pattern generation is split up in two parts (see Figure 9 on page 42 and Figure 10 on page 43). The first part, required to be performed once only, deals with position related events (see Figure 9). The second part, to be repeated for each single velocity to be simulated, deals with time related events (see Figure 10). The following examples of algorithms for signal pattern generation (see section 4.2.6.3.3 on page 44) deals with the position related part only.

Figure 9 on page 42 and Figure 10 on page 43 visualise the process described above. The upper diagram in Figure 9 is an example of flux level (ϕ) through the Reference Loop for various geometrical positions (as determined from section 4.2.6.2 on page 36). The lower curve of the middle diagram (I_{LOW}) is the 4.5 MHz current through a weakest possible Balise considering the lower limits of the transfer response characteristics of UNISIG SUBSET-100. A similar curve is shown with dotted lines for the strongest possible Balise (I_{HIGH}). The upper curve of the middle diagram (I_{TH}) is the actual 4.5 MHz current through the Reference Loop that results in an Up-link signal reaching the BTM function threshold (result from section 4.2.6.2 on page 36). The lower diagram of Figure 9 constitutes the calculated current ($I_{(x)}$) versus position that is to be driven through a Reference Loop positioned directly underneath the Antenna Unit in position $[X = 0, Y = 0, Z = \text{maximum height}]$ in order to simulate a Balise passage. Finally, Figure 10 illustrates how to consider time-related events, thus calculating the current through the Reference Loop as a function of time (I_{CALC}). The time scale is dependent on the velocity to be simulated. The Balise start up behaviour mentioned above is also indicated.

Please note that the normalisation with respect to I_{THREF} has to be performed. This is performed by calculating the difference in threshold value between the geometrical reference point (I_{THREF}) and the threshold value for each position.

Please note that I_{THREF} is one single value taken at the reference position during free air conditions without any tilting (i.e., nominal conditions).

Please also note that potential changes of worst case conditions due to changed performance at the temperature extremes and possible dependency for various test patterns shall be considered.

The temperature effect (increase or decrease effects) should cause (when it causes a flux reduction) a lowering of the lowest Tele-powering radiation diagram in nominal conditions, for the case of the weakest Balise. On the contrary, a flux increase should apply to the highest Tele-powering radiation diagram in nominal conditions, for the strongest Balise. Similarly for the temperature effect on the Up-link diagrams, an increase of the reference current due to temperature should raise by the same amount the highest Up-link diagram applicable to the weakest Balise, and a decrease should result in a lowering of the same amount of the lowest Up-link diagrams applicable to the strongest Balise. Regarding the Up-link diagrams, the same corrections as for temperature dependencies also apply to possible dependency for various test patterns.

The time scale shall be determined using the following equation:

$$t = \frac{x}{v}$$

where v is the velocity to be simulated (supplier dependent).

The following cases shall as a minimum apply:

- Each 50 km/h from 20 km/h up to and including the maximum speed for the break points in the lateral deviation versus speed diagrams defined by the supplier. This shall be performed for all the Antenna Unit heights defined by chapter A1 on page 109.
- Low speed conditions (approximately 10 km/h) at minimum height and no lateral deviation.

$I_{(x)}$ of Figure 9 shall be calculated using the algorithm exemplified in section 4.2.6.3.3 on page 44.

4.2.6.3.2 Example of Signal Pattern Generation

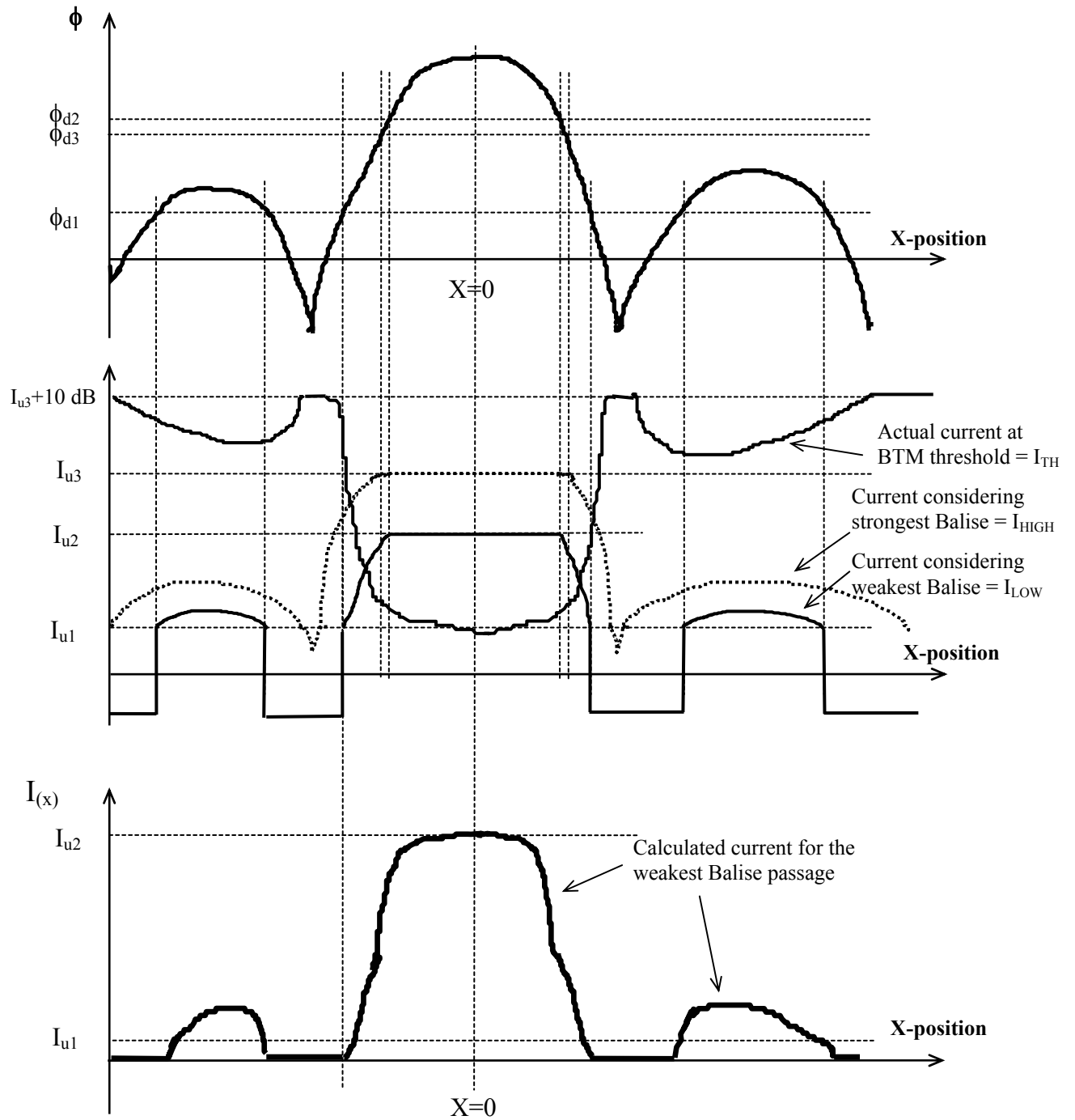

Figure 9: Example of Signal Pattern Generation (position related events)

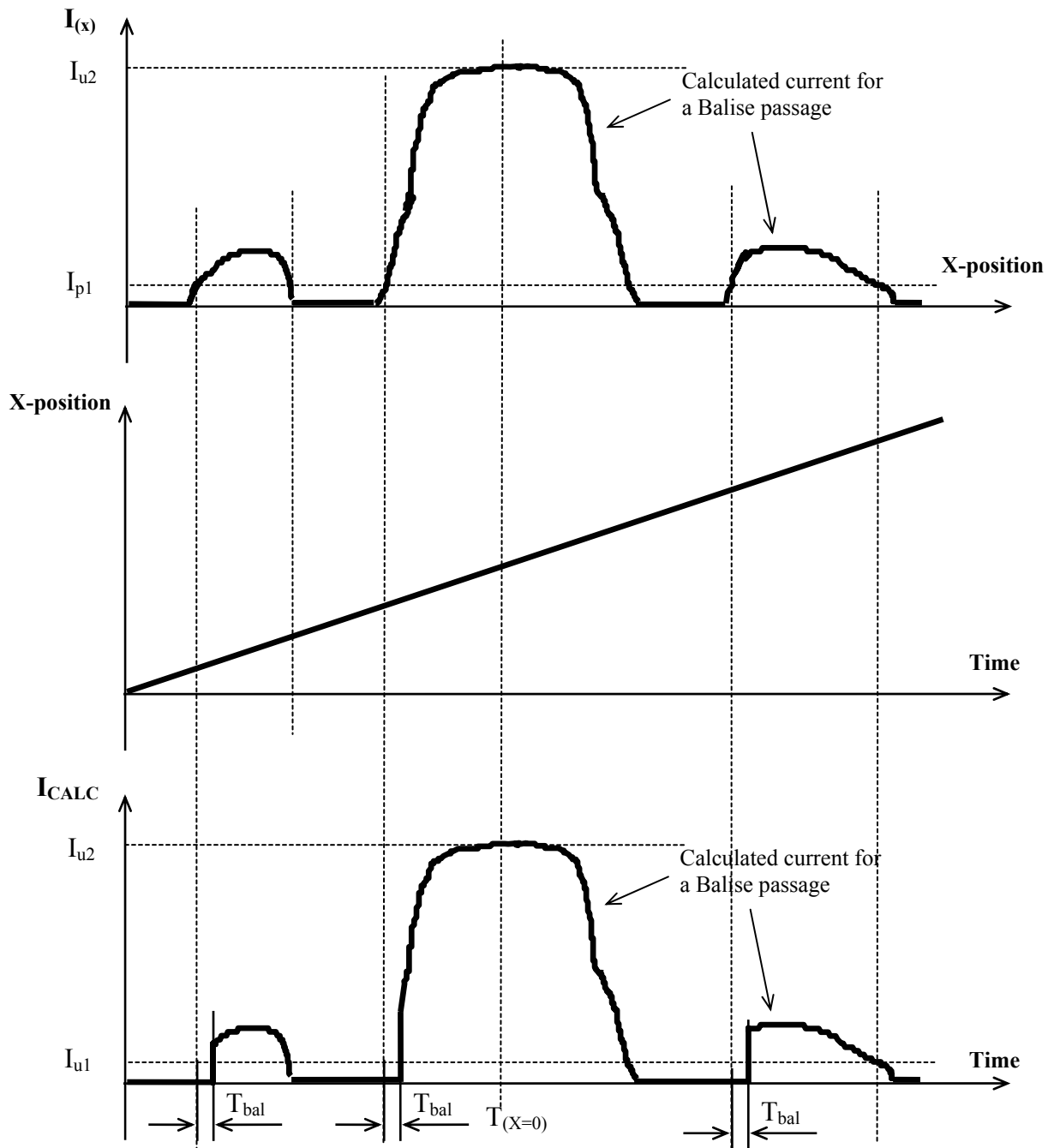

Figure 10: Example of Signal Pattern Generation (time related events)

I_{p1} is the current level corresponding to the point of time when the flux level exceeds Φ_{d1} . In general, the delay T_{bal} is applicable after the point of time when the flux exceeds Φ_{d1} . However, this only has potential impact on the ability to detect (weakest possible) Balises, since it shortens the contact length. When dealing with the strongest possible Balise, the focus is on cross-talk (where Balise Detection aspects are irrelevant from a contact length point of view). Hence, it is adequate to ignore aspects related to T_{bal} for the strongest possible Balise. Consequently T_{bal} should be ignored when generating signal patterns for the strongest possible Balise.

4.2.6.3.3 Example of Algorithm for Signal Pattern Generation

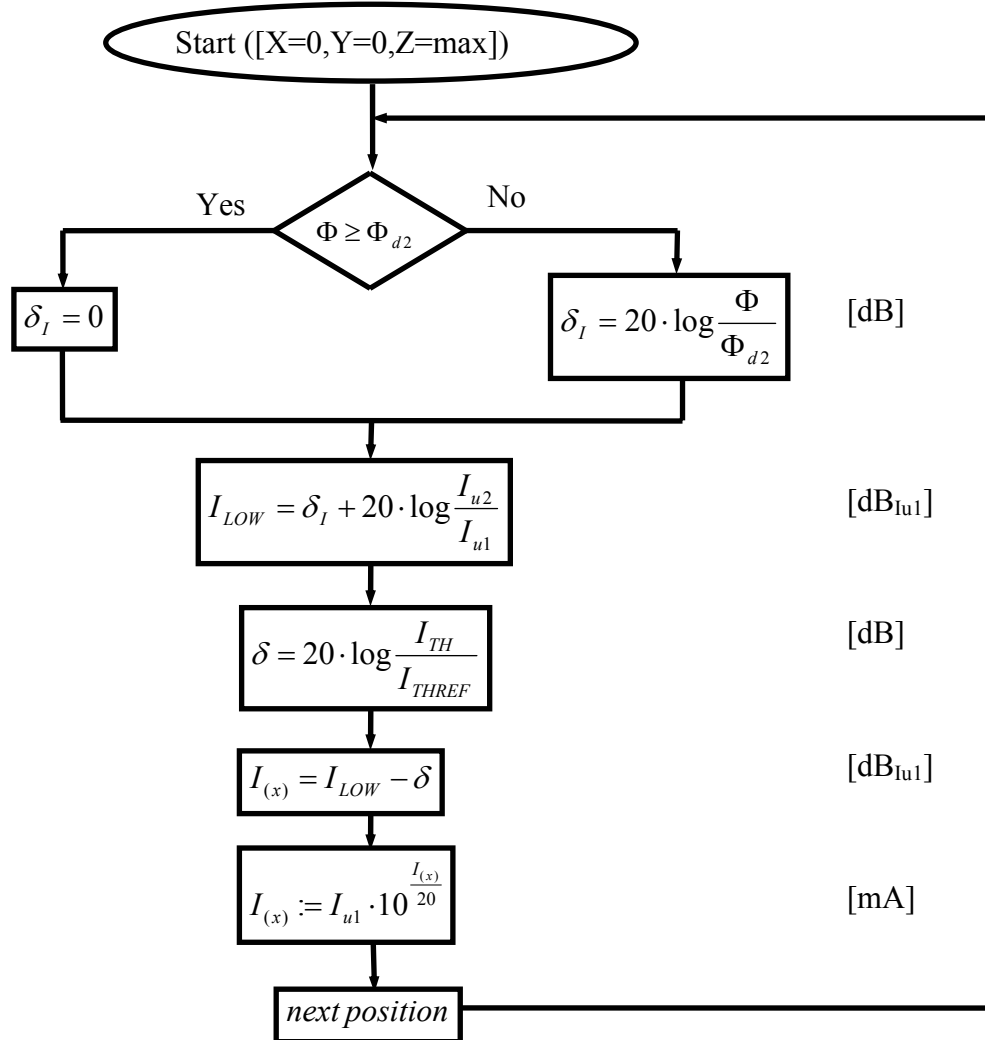

Figure 11: Algorithm for Signal Pattern Generation, weakest Balise

Please note that it is the principle that is shown in Figure 11 only, and that the algorithm deals with the position related events illustrated in Figure 9 only. Also margins for variations over temperature and possible dependency for various test patterns must be considered (see section 4.2.6.3.1 on page 40). Units are indicated to the right of the figure.

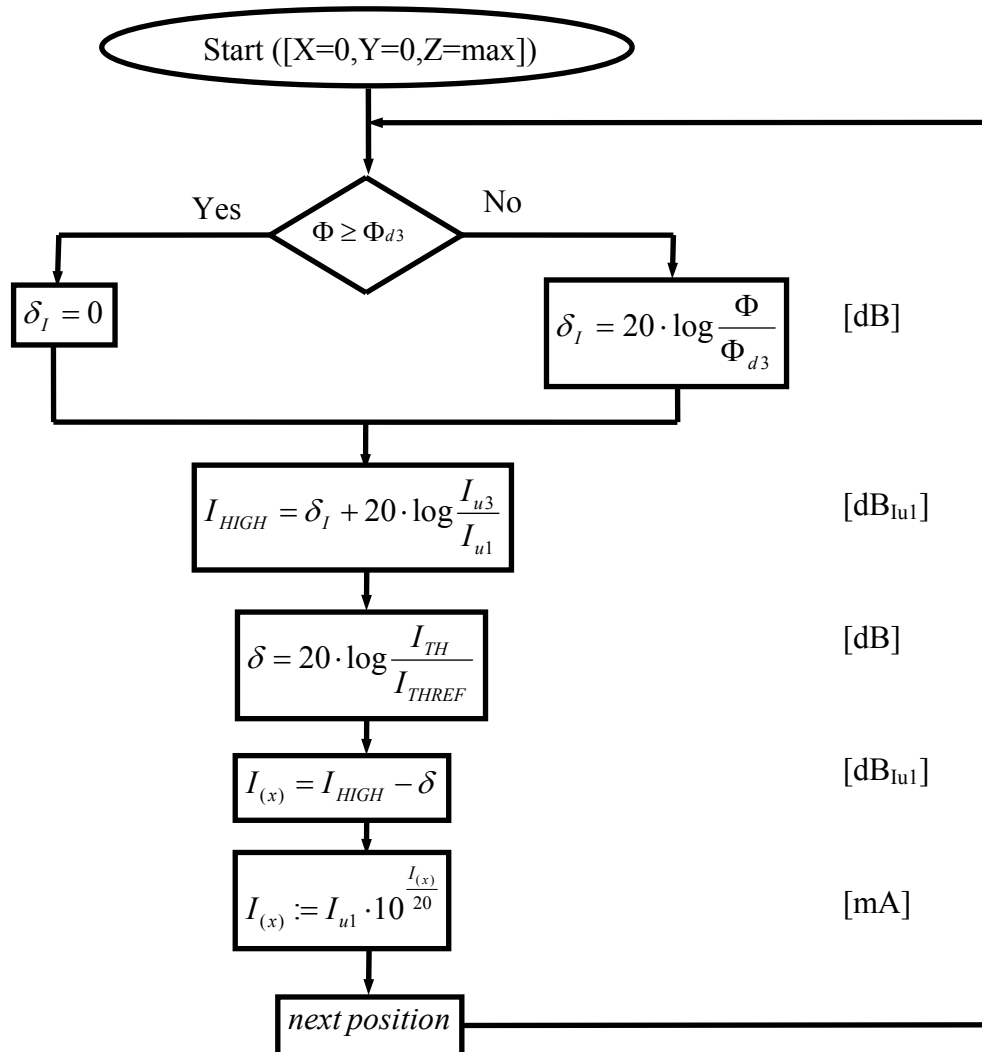

Figure 12: Algorithm for Signal Pattern Generation, strongest Balise

Please note that it is the principle that is shown in Figure 12 only, and that the algorithm deals with the position related events illustrated in Figure 9 only. Also margins for variations over temperature and possible dependency for various test patterns must be considered (see section 4.2.6.3.1 on page 40). Units are indicated to the right of the figure.

4.2.6.4 Transmission Tests

4.2.6.4.1 General Description, Transmission Tests

The purpose of this test is to determine the capability of the Antenna Unit - BTM function combination with respect to transmission of data enabling Balise Detection, reliable data transmission, side lobe management, and location accuracy during simulated dynamic conditions. It also serves as a test of system dynamics (strongest and weakest possible signals will occur during the test).

Criteria for sufficient transmission with respect to safety (Balise Detect) and availability (Telegram Decoding) are defined in UNISIG SUBSET-100 (certain system specific requirements on the minimum number of transmitted bits).

The input signal to the Reference Loop generating the Up-link signal shall be in accordance with results from section 4.2.6.3 on page 40. The time scale shall be selected in order to comply with speeds at each 50 km/h from 20 km/h up to the maximum specified velocity for the lateral deviation (Y position) to be simulated. The odometer input signal shall be selected accordingly.

For each simulated case (simulating various lateral deviations and vertical heights), the BTM function output signal shall be observed and evaluated via Interface 'V_K'. The BTM function shall be set in the normal operational mode.

The criteria for the Antenna Unit - BTM function being able to correctly handle a certain sequence is that the BTM function transmits the required amount of bits (both 'Data for Balise Detection' and 'Data for Telegram Decoding' shall be evaluated).

In order to evaluate the correctness of when transmission occurred, the Balise simulations should be accurately allocated (at an exact distance from a chosen reference point) in a "virtual test line" used for each test sequence. The evolution of each sequence will be controlled by the Laboratory Test Management System (the LTMS). The LTMS will off-line scale each position based Balise pattern into a sequence of time based patterns according to the desired Balise "positions" and to the chosen train speed (see Figure 10 on page 43). After this, the LTMS down-loads all the relevant data to the arbitrary generator (RSG), and finally looks at the real-time odometer data coming from the LTOM. The LTOM issues a triggering pulse for the arbitrary generator when the odometer information of each Balise starting is reached. The positions of the transmission from the BTM function will be checked against the reference position of the simulated sequence. Additionally, the RSG shall provide a trigger to item the Interface 'V_K' adapter indicating start of a 'zero' ASK bit, and the BTM function shall provide a trigger to the RSG synchronising ASK bit generation with the Tele-powering modulation pulses.

All Test Conditions according to section 4.1.4 on page 19 shall be considered. Certain tailoring is defined by chapter A3 of Annex A on page 111.

The present tests are performed with the antenna located in the reference position and in nominal environmental conditions. The applicable specific test conditions are simulated by using the radiation diagrams corresponding to such real conditions.

4.2.6.4.2 Test Procedure, Transmission Tests

The test set-up in accordance with section 4.1.2 on page 15 applies. Steps 1 through 5 below constitute calibration of the level of the generated Up-link signal for the test case in consideration. Succeeding steps form the actual test procedure.

1. For each individual test case (of those listed in chapters A1, A3 and section 4.1.4.2), calculate the position related pattern exemplified in Figure 9 on page 42 (thus obtaining $I_{(x)}$) using the radiation pattern data obtained in section 4.2.6.2.2, properly scaled to the reference position used for the Antenna Unit under test. Thereafter, calculate the time related pattern for weakest Balise passage, using the equation of section 4.2.6.3.1 on page 40, and exemplified in Figure 10 on page 43 (thus obtaining I_{CALC}). For the purpose of the latter calculation, a speed of 26 km/h shall be applied.
2. Position the Antenna Unit at a position corresponding to $X = 0$, $Y = 0$, and at maximum height defined by the Antenna Unit supplier (i.e., the same reference position used for the evaluation of the radiation diagrams). Set the BTM function in “normal toggling operational mode”, and use nominal test conditions (see section 4.1.4.1 on page 19).
3. Set the RF switch in position P1 (enabling generation of Up-link signals).
4. Set the time and odometer input data (provided by the LTOM) to comply with the required speed of 26 km/h. Please note that there might be system-related properties setting certain limitations on properties such as acceleration etceteras.
5. Set the arbitrary generator to generate a nominal ASK Up-link signal and apply the time related pattern obtained from step 1 above. Adjust the output level from the RSG_1 (by means of subsequent Balise passage simulations) such that the correct level (within ± 0.3 dB) is obtained at the below defined two points. The current is measured by the oscilloscope, and the related transfer response of the Current Sense balun is in accordance UNISIG SUBSET-085. Please observe that the current measured by the oscilloscope needs to be compensated for the B-factor of the Reference Loop (i.e., the measured target current shall be the desired Reference Loop current divided by B). Please observe also the definitions of UNISIG SUBSET-100 for the definition of the signal level. The level of the up-link pattern shall be checked at the following points:
 - The position in time where the peak current in the calculated pattern occurs.
 - The position in time closest to where the current exceeds the receiver threshold (measured at the reference position of the Antenna Unit) by 1 dB (but never lower than 0.5 dB above the threshold). The first position in time after the centre of the main lobe should be selected for this purpose.

In case there are problems fulfilling the target for both positions, the position close to the threshold has priority. In case not fulfilling both targets, this observation shall be recorded in the test record, and it shall be made clear that this is a test set-up imperfection.^{1 2}

6. Re-calculate the time based pattern to be used for testing according to the equation of section 4.2.6.3.1 on page 40, according to the example in Figure 10 on page 43 (I_{CALC}), and using one applicable velocity defined by section 4.2.6.3.1 on page 40.

¹ It is also important to verify, off-line, that the Tele-powering signal does not influence the actual Up-link signal driven through the Reference Loop.

² This check needs to be performed for the reference position only. The purpose is to identify potential test set-up imperfections.

7. Set the time and odometer input data (provided by the LTOM) to comply with the desired speed (to be defined by the manufacturer of the BTM function and defined by section 4.2.6.3.1 on page 40). Please note that there might be system related properties setting certain limitations on properties such as acceleration etceteras.
8. Perform a sequence of at least 10 subsequent sweeps with the data determined above and record the output from the BTM function (via Interface 'V_K'), together with the reference location data provided by the LTOM. Measure, by the oscilloscope, and record also the value of the up-link current peak at each Balise passage simulation, evidencing the occurrence of cases of peak values slightly out of tolerance, possibly due to drifts of the RSG_1.³
9. Repeat steps 6 through 8 for all remaining applicable velocities defined by section 4.2.6.3.1 on page 40.
10. Repeat steps 1 through 9 or 6 through 9 (as appropriate) for all remaining combinations of longitudinal ranges, lateral displacements and heights (as defined by the Antenna Unit supplier) using the cases defined in chapter A1, on page 109 and chapter A3 on page 111. Please note that the physical location of the Antenna Unit and the Reference Loop shall not be changed.
11. Repeat steps 1 through 9 or 6 through 9 (as appropriate) for all remaining specific test conditions defined by section 4.1.4.2 on page 21 and chapter A3 on page 111. Please note that the physical location of the Antenna Unit and the Reference Loop shall not be changed, and that no debris or metallic objects shall be present (the influence of such conditions is included in the data from the radiation pattern this is the basis for the calculation of the signal pattern).

4.2.6.4.3 Acceptance Criteria, Transmission Tests

The criterion is that the BTM function is able to correctly receive a Balise during the simulated sequence and transmit the information via Interface 'K'. This means that the following properties are correctly reported:

- a. Data for Balise Detection during a sufficient period (as defined by SUBSET-100)
- b. Correct data for Telegram Decoding during a sufficient period (as defined by SUBSET-100)
- c. No report of ERTMS Unavailability data
- d. No report of Eurobalise Reception data
- e. Correct Link Test Data
- f. Correct Antenna/BTM ID Data
- g. Correct Link ID Data
- h. Correct Bit Counter Data
- i. Correct CRC
- j. Correct Signal Strength Data (if available)

Transmission of a number of bits sufficient for creating a Balise Detect outside a Balise passage simulation (considering all relevant delays) shall be regarded as a failure condition.

³ The measurement is performed within a time window corresponding to about 20 mm at the current test speed.

4.2.6.5 Electrical Tele-powering Characteristics

This is included in the verifications according to UNISIG SUBSET-085.

4.2.6.6 Maximum Flux Level

4.2.6.6.1 General Description, Maximum Flux Level

The purpose of this test is to systematically evaluate the performance of the Tele-powering signal generated by the Antenna Unit - BTM function combination. The maximum flux generated through a Reference Loop is subject to testing.

The output signal shall be evaluated during static conditions in toggling Tele-powering mode. The output signal shall be measured using a Reference Loop. The Reference Loop should be subjected to various load conditions during maximum flux measurements.

The BTM function shall be forced to the applicable mode using suitable commands inserted via Interface V_1 .

Geometrical test points and applicable test conditions are defined by sections A4.1 on page 112 and A4.2 on page 112.

The maximum flux level test shall determine the flux level through the Reference Loop under various load conditions, and for various geometrical test points. The different load conditions shall be tailored to simulate worst case conditions as defined by UNISIG SUBSET-100. Geometrical test points are defined by section A4.2 on page 112.

4.2.6.6.2 Specific Test Set-up for Maximum Flux Level verification

The test set-up is shown in Figure 13 below. Annex E on page 134 gives an example of suitable test equipment.

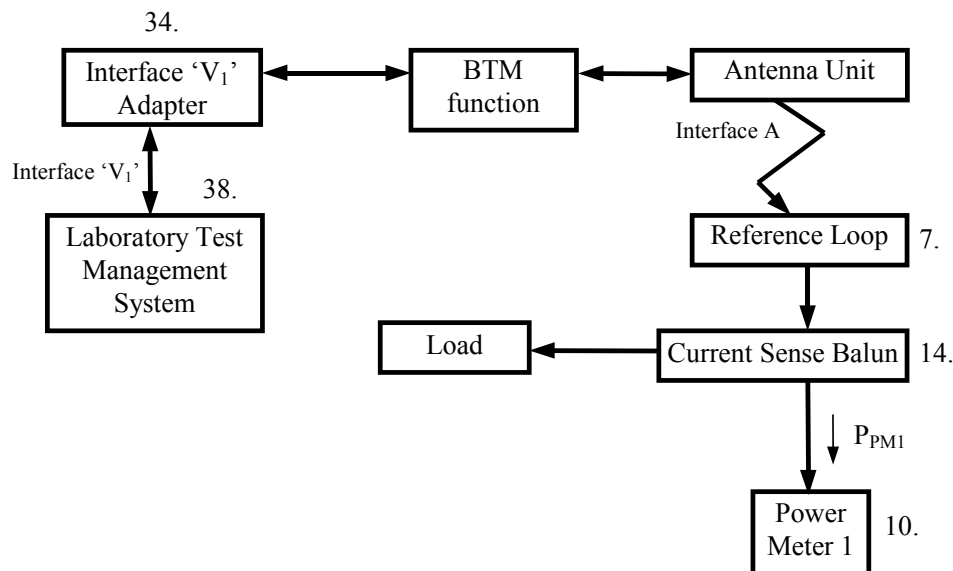

Figure 13: Test set-up for Maximum Flux Level Tests

Item 10, is computer controlled via the Laboratory Test Management System (the computer control is intentionally not indicated in the figure).

4.2.6.6.3 Test Procedure, Maximum Flux Level

The test set-up in accordance with section 4.2.6.6.2 on page 49 applies.

1. Connect the equipment as defined by section 4.2.6.6.2 on page 49, and ensure that the Current Sense balun is calibrated as defined by UNISIG SUBSET-085.
2. Connect a load to the Reference Loop forming a total impedance in the circuit simulating worst case conditions as defined by UNISIG SUBSET-100 (i.e., the sum of the Reference Loop impedance and the external load and the Current Sense balun shall constitute conditions as defined by UNISIG SUBSET-100).
3. Position the Antenna Unit in the geometrical test point [X = 0, Y = 0, Z = minimum height].
4. Command the BTM function to its normal operational mode regarding toggling Tele-powering, or to any other mode equivalent to this (from the point of view of the maximum flux level evaluation).
5. Record the power level of power meter 1 (P_{PM1}).
6. Calculate the flux through the Reference Loop using the following equation:

$$\Phi = \frac{\sqrt{P_{PM1}} \cdot B \cdot (Z_{load} + Z_{loop})}{\sqrt{k \cdot |Z_A|} \cdot 2 \cdot \pi \cdot f_{27}}$$

where: P_{PM1} is power in Watt recorded by power meter 1
B is the Reference Loop transfer matching ratio
 Z_{loop} is the actual impedance of the Reference Loop in the absence of any antenna
 Z_{load} is the external load impedance connected to the Reference Loop
 f_{27} is the Tele-powering frequency (27.095 MHz)
k is the calibration factor determined by UNISIG SUBSET-085
 Z_A is defined in UNISIG SUBSET-085

7. Perform steps 5 and 6 for all the other geometrical test points defined by section A4.2 on page 112.
8. Repeat steps 2 through 7 for all applicable worst case load conditions.

Please observe that the actual load values defined in this test procedure constitute the total load of the circuit. This means that a certain load defined above is the sum of the external load connected to the Reference Loop, the influence of the Current Sense balun, and the actual Reference Loop impedance. Hence, the Reference Loop impedance has to be measured separately, and the impedance of the combination of the Current Sense balun and the external load has to be measured separately, and the total impedance has to be calculated. This has to be characterised prior to the test.

4.2.6.6.4 Acceptance Criteria, Maximum Flux Level

The requirement is that the flux level never exceeds ϕ_{d4} .

4.2.6.7 Up-link Characteristics

4.2.6.7.1 General Description, Up-link characteristics

The purpose of this test is to systematically evaluate the BTM function capability with respect to extremes of the electrical characteristics of the Up-link signal (such as carrier frequency, t_{pudelay} , t_{50} , and amplitude jitter). Suitable test patterns shall be generated by the arbitrary generator (RSG) in order to test the properties mentioned above.

The input signal to the Reference Loop generating the Up-link signal shall be an ASK signal with “imperfections” as described above. Furthermore, an additional modulation in accordance with section 4.2.6.3 on page 40 shall be present in order to simulate a Balise passage. Test data from sections 4.2.6.2 on page 36 and 4.2.6.3 on page 40 shall be used for creation of the simulated Balise passage. The BTM function shall be set to normal operational mode.

Only a limited amount of combinations of lateral deviation and vertical height will be considered (see section A4.2 on page 112). The BTM function output signal shall be observed via Interface V_K and evaluated.

The criteria for the Antenna Unit and BTM function being able to correctly handle certain sequence are defined in section 4.2.6.4.3 on page 48.

Test Conditions shall be in accordance with section A4.1 on page 112.

4.2.6.7.2 Test Procedure, Electrical Up-link Characteristics

The test set-up in accordance with section 4.1.2 on page 15 applies.

Suitable test patterns for the arbitrary generator (RSG) shall be developed that simulate the following extremes of the Up-link signal:

- Carrier frequency = 4.0 MHz and 4.7 MHz.
- $t_{\text{pudelay}} = 0.6 \mu\text{s}$ and $1.65 \mu\text{s}$.
- $t_{50} = 2 \mu\text{s}$ and $5 \mu\text{s}$.
- Amplitude Jitter = ± 1.0 dB.

The envelope of the pulse shall be approximately exponentially decreasing. See Figure 6 on page 20.

One main aspect as listed above shall be evaluated at a time. Start-up and steady state behaviour shall be considered where applicable. For the purpose of selection ‘R3’ defined in section A4.2 on page 112, simulation of weakest Balise (I_{LOW}) shall apply, and for the purpose of selection ‘R5’, simulation of strongest Balise (I_{HIGH}) shall apply. Please observe the definitions of UNISIG SUBSET-100 for the definition of the signal level.

Apart from these modifications of the ASK signal and the selection of geometrical test points and test conditions, the test procedure is identical to the procedure defined in section 4.2.6.4.2 on page 47 (Transmission Tests).

Geometrical test points and test conditions are defined by chapter A4.1 on page 112, and chapter A4.2 on page 112.

4.2.6.7.3 Acceptance Criteria, Electrical Up-link Characteristics

See section 4.2.6.4.3 on page 48.

4.2.6.8 Cross-talk Immunity

4.2.6.8.1 General Description, Cross-talk Immunity

Cross-talk tests shall determine whether there are any potential cross-talk situations within the defined geometrical region and during the test conditions defined by section 4.1.4 on page 19. Where applicable, certain cross-talk margins should be evaluated. Specific cable related cross-talk is not included in this section, but separately dealt with in 4.2.6.9 on page 55.

The Tele-powering flux shall be measured using a Reference Loop. The recorded flux level (ϕ) shall after this be used for determining the response from a strongest worst case Balise (I_{HIGH}) utilising the upper limits of the transfer response curve defined by UNISIG SUBSET-100. Thereafter, the Reference Loop shall be connected to a signal generator generating an ASK Up-link signal that simulates a representative Balise passage (see Figure 8 on page 36), and carrying an 'all zero' sequence with a peak current level as determined above (I_{HIGH}). The BTM function output response shall be observed via Interface 'V_K'. The requirement is that there is no transmission of bits sufficient for creating a Balise Detect. Thereafter, the peak current level shall be gradually increased until Balise detection is possible, or until a peak current value of $I_{u3} + 20$ dB is reached. The procedure is similar to the method described in section 4.2.6.2.1 on page 36. The difference is that current levels up to the maximum peak current level $I_{u3} + 20$ dB are quantitatively tested to evaluate the margin for cross-talk.

This procedure shall be performed for all the geometrical positions defined by chapter A2 on page 110, and for all test conditions defined by section 4.1.4 on page 19. Certain tailoring is defined by chapter A3 on page 111.

4.2.6.8.2 Test Procedure, Cross-talk Immunity

The test set-up in accordance with section 4.1.2 on page 15 applies.

1. Position the Antenna Unit in the first geometrical test point defined by chapter A2 on page 110 and select nominal test conditions defined by section 4.1.4.1 on page 19.
2. Set the RF switches in positions P2 and P3 (thus connecting the power meter 2).
3. Command the BTM function to its normal operational mode regarding toggling Tele-powering, or to any other mode equivalent to this (from the point of view of the Cross-talk evaluation).
4. Record the value of power meter 2.
5. Repeat step 4 for all remaining geometrical test points defined by chapter A2 on page 110 and chapter A3 on page 111.
6. Calculate the flux for all geometrical test points using the equation defined in section 4.2.6.2.2 on page 38.
7. Determine the corresponding worst case (strongest) response from the Balise (I_{HIGH}) as described in section 4.2.6.8.1 on page 52.
8. Set the RF switch in position P1 (thus enabling generation of Up-link signals).
9. Set the arbitrary generator to generate an Up-link signal in accordance with Figure 8 on page 36. The initial current setting shall be the I_{u3} current. The current is measured by the oscilloscope, and the related transfer response of the Current Sense balun is in accordance with UNISIG SUBSET-085. Please observe that the current measured by the oscilloscope needs to be compensated for the B-factor of the Reference Loop (i.e., the measured target current shall be the desired Reference Loop current divided by B). Please observe also the definitions of UNISIG SUBSET-100 for the definition of the signal level. Set the time and odometer information to comply with a speed of 100 km/h.
10. Position the Antenna Unit in the first geometrical test point defined by chapter A2 on page 110 and select nominal test conditions defined by section 4.1.4.1 on page 19.
11. Record the output from the BTM function (via Interface 'V_K') and determine whether Balise detection is possible or not. That is, no transmission of sufficient amount of bits in accordance with UNISIG SUBSET-100.
12. In case that Balise detect was not possible, increase the peak current level in steps of 0.5 dB until Balise detect becomes possible, or until $I_{u3} + 20$ dB is reached. Repeat steps 11 and 12 until the margin is determined.
13. Repeat steps 11 and 12 for all remaining geometrical test points defined by chapter A2 on page 110 and chapter A3 on page 111, using the appropriate I_{HIGH} for each separate point.
14. Repeat steps 1 through 13 for all specific test conditions defined by section 4.1.4.2 on page 21 and chapter A3 on page 111. Please observe that "nominal conditions" of step 1 is substituted by the relevant "specific condition" for each subsequent pass.

It must be verified that reliable Up-link measurements can be performed in the presence of the applicable 27 MHz Tele-powering signal.

4.2.6.8.3 Acceptance Criteria, Cross-talk Immunity

4.2.6.8.3.1 General

The requirement is that no cross-talk occurs. There is no explicit requirement on a certain margin, but the defined test procedure makes it possible to perform this evaluation. The evaluation of the cross-talk margin must be separated into the two cases defined by UNISIG SUBSET-100.

4.2.6.8.3.2 One Balise and one Antenna Unit

This case is applicable for lateral deviations of 1400 mm or more.

The cross-talk margin in dB is evaluated as follows:

$$Margin = \{\Phi \leq \Phi_{d3}\} = 20 \cdot \log \frac{I_{CT}}{I_{u3}} + 20 \cdot \log \frac{\Phi_{d3}}{\Phi}$$

$$Margin = \{\Phi > \Phi_{d3}\} = 20 \cdot \log \frac{I_{CT}}{I_{u3}}$$

Where: ϕ is the actual flux level in nVs for the geometrical position in question
 ϕ_{d3} is in nVs, and defined by the transfer characteristics of the Balise
 I_{CT} is the actual current in mA for when cross-talk occurs
 I_{u3} is in mA, and defined by the transfer characteristics of the Balise
Margin is the cross-talk margin in dB

4.2.6.8.3.3 One Balise and two Antenna Units

This case is applicable for lateral deviations of 3000 mm or more, and for longitudinal deviations as defined by the manufacturer of the Antenna Unit.

The cross-talk margin in dB is evaluated as follows:

$$Margin = 20 \cdot \log \frac{I_{CT}}{I_{u3}}$$

Where: I_{CT} is the actual current in mA for when cross-talk occurs
 I_{u3} is in mA, and defined by the transfer characteristics of the Balise
Margin is the cross-talk margin in dB

4.2.6.9.3 Test Procedure, Up-link Cross-talk from cable to Antenna Unit

The test set-up shown in Figure 14 on page 55 shall be used. The resistor R1 shall be 350 Ω and R2 shall be 400 Ω . The distance D is the position in the x direction, and shall be in the range from -1000 mm to 1000 mm. This test determines the signal received in an Antenna induced from a cable with the current 2 mA and 10 mA for E = 93 mm and E = 400 mm respectively. See Figure 14 on page 55 for definition of E.

1. Position the Antenna at position D = -1000 mm and E = 93 mm and set the BTM function in normal operational mode.
2. Set the Signal Generator to generate a 4.5 MHz ASK Up-link signal carrying an 'all zero' sequence, and the current 'I' to 2 mA. For the suggested current probe, a current of 1 mA will give a voltage of 1 mV into 50 Ω . The definitions of UNISIG SUBSET-100 shall be used for the definition of the signal level.
3. Verify that the response from the Antenna Unit is below V_{th} by observing output data via Interface ' V_K ' (i.e., no transmission of sufficient amount of 'Data for Balise Detection' bits in accordance with UNISIG SUBSET-100).
4. Position the Antenna at regular intervals of +40 mm, up to the distance D = 1000 mm. For each position, verify that the response is below V_{th} .
5. Position the Antenna at position D = -1000 mm and E = 400 mm.
6. Set the Signal Generator to generate a 4.5 MHz ASK Up-link signal carrying an 'all zero' sequence, and the current 'I' to 10 mA.
7. Verify that the response from the Antenna Unit is below V_{th} by observing output data via Interface ' V_K ' (i.e., no transmission of sufficient amount of 'Data for Balise Detection' bits in accordance with UNISIG SUBSET-100).
8. Position the Antenna at regular intervals of +40 mm, up to the distance D = 1000 mm. For each position, verify that the response is below V_{th} .

4.2.6.9.4 Acceptance Criteria, Cross-talk Immunity with Cables

The response from the Antenna Unit shall be below V_{th} (i.e., no response sufficient for making the BTM function able to create the amount of 'Data for Balise Detection' bits in accordance with UNISIG SUBSET-100).

4.2.6.10 Balise Detect Ability Supervision

This is included in the verifications according to UNISIG SUBSET-085.

4.3 Laboratory Tests, Alternative 2 Interface

4.3.1 Electrical Data

See section 4.2.1 on page 25.

4.3.2 Data Transmission

4.3.2.1 General Description, Data Transmission

This section defines the test procedure for verifying the data transmission. The test procedure includes verification of the following properties:

- Presence of Data signal
- Presence of CLK signal

4.3.2.2 Test Pattern, Data Transmission

The RSG shall be programmed such that a repetitive 00001110101 ASK bit pattern is continuously transmitted through the air gap (Interface 'G').

4.3.2.3 Test Procedure, Data Transmission

1. Position the antenna such that the manufacturer dependent nominal vertical distance is obtained with respect to the Reference Loop, and that $X=0$ and $Y=0$ with respect to the Reference Loop.
2. Adjust the output level from the RSG such that an Up-link current of $I_{u1} +3$ dB is obtained. Please observe that the Up-link current must be modulated as defined in Figure 8 on page 36.
3. Temporarily connect the oscilloscope to Interface 'K'. Please observe that a floating measurement shall be performed (e.g., using two channels and performing a differential measurement). The oscilloscope should be triggered from the output of the RSG.
4. Record the resulting transmission of at least one repetition of the defined pattern.
5. Verify the existence of Data signal.
6. Verify the existence of CLK signal.

4.3.2.4 Acceptance Criteria, Data Transmission

- a. The test shall verify the existence of Data signal as specified in UNISIG SUBSET-101.
- b. The test shall verify the existence of CLK signal as specified in UNISIG SUBSET-101.

4.3.3 Timing Requirements

4.3.3.1 General Description, Timing Requirements

This section defines the test procedure for verifying the timing requirements. The test procedure includes verification of the following properties:

- Correctness of 50 kHz ASK bit data rate
- Correctness of phase position between various channels (if more than one is implemented)
- Correctness of the relation between the Data and CLK signals
- Propagation delay from Interface 'G' to Interface 'K'

4.3.3.2 Test Pattern, Timing Requirements

The RSG shall be programmed such that a repeated 40 ASK bit pattern starting with 8 consecutive 'zeros' followed by 8 consecutive 'ones', and finally followed by toggling 'zeros' and 'ones' up to the end of the of the pattern is continuously transmitted through the air gap (Interface 'G').

4.3.3.3 Test Procedure, Timing Requirements

1. Position the antenna such that the manufacturer dependent nominal vertical distance is obtained with respect to the Reference Loop, and that $X=0$ and $Y=0$ with respect to the Reference Loop.
2. Adjust the output level from the RSG such that an Up-link current of I_{u2} is obtained. Please observe that the Up-link current must be modulated as defined in Figure 8 on page 36.
3. Temporarily connect the oscilloscope to Interface 'K'. Please observe that a floating measurement shall be performed (e.g., using two channels and performing a differential measurement). The oscilloscope should be triggered from the output of the RSG.
4. Record the resulting transmission of at least one full bit pattern repetition in the air gap.
5. Evaluate the 50 kHz ASK bit data rate.
6. In case more than one channel is implemented, measure the phase position between various channels.
7. Evaluate the phase position between the positive edge of the CLK signal and the Data signal, and the length of the CLK signal.
8. Evaluate the propagation delay between the air gap signal and the data transmitted through Interface 'K'.

4.3.3.4 Acceptance Criteria, Timing Requirements

- a. The ASK bit data rate shall be 50 kbits/s within the tolerance specified in UNISIG SUBSET-100.
- b. The phase difference between the various channels (if more than one is implemented) shall be less than what is specified in UNISIG SUBSET-101.
- c. The phase position between the positive edge of the CLK signal and the Data signal, and the length of the CLK signal shall comply with the definitions of UNISIG SUBSET-101.
- d. The propagation delay shall be less than what is specified in UNISIG SUBSET-101.

Data shall not be evaluated in case a forced link test occurs.

4.3.4 Functional Data

4.3.4.1 General Description, Functional Data

This section defines the test procedure for verifying the correct transmission of data from a functional perspective. The test procedure includes verification of the following properties:

- Transmission of Data
- Handling of Tele-powering being switched off
- Handling of Eurobalise (FSK) signals
- Transmission of link tests

In case multiple channels are implemented, the requirements related to diversified data defined in UNISIG SUBSET-101 will also be verified from a transmitter perspective. Finally, simulation of a permanently failing BTM functionality is also simulated.

4.3.4.2 Test Patterns, Functional Data

See section 4.2.4.2 on page 28.

4.3.4.3 Test Procedure, Functional Data

See section 4.2.4.3 on page 29.

4.3.4.4 Acceptance Criteria, Functional Data

For each of the acquisitions performed in steps 3 and 5, it shall be verified that:

- a. Data complies with, and is consistently synchronised with, the air gap signal.

For the acquisitions performed in step 9, it shall be verified that:

- b. The CLK signal is at constant polarity as stated in UNISIG SUBSET-101.

For the acquisition performed in step 11, it shall be verified that:

- c. Data and CLK signals comply with the requirements of UNISIG SUBSET-101 defined for “Eurobalise mode”.

For the acquisition performed in step 15, it shall be verified that:

- d. The interface ‘K’ channel activity is terminated after the introduction of the failure condition.

For the acquisition performed in step 13, it shall be verified that:

- e. Link check patterns are transmitted in accordance with the requirements of UNISIG SUBSET-101.

Specifically for step 18 (if applicable), aspects on diversified data shall be considered. See requirements in UNISIG SUBSET-101.

4.3.5 Link Check Functionality

4.3.5.1 General Description, Link Check Functionality

This section defines the test procedure for verifying the correct transmission of signals used for on-line supervision of the Interface 'K' link. The test procedure includes verification of the following properties:

- Time between transmissions of link check patterns
- Correctness of link check pattern
- Blocking of link checks during reception of Balise data

4.3.5.2 Test Pattern, Link Check Functionality

See section 4.2.5.2 on page 32.

4.3.5.3 Test Procedure, Link Check Functionality

See section 4.2.5.3 on page 32.

4.3.5.4 Acceptance Criteria, Link Check Functionality

For the acquisition performed up to step 3, it shall be verified that the link test pattern defined in UNISIG SUBSET-101 is transmitted.

For the acquisition performed up to step 3, it shall be verified that there is at least one approved link test within the defined sliding 500 ms time interval.

For the acquisition performed in step 5, it shall be verified that the following is transmitted for a period of time not exceeding 1 s:

- a. Normal ASK data is transmitted via Interface 'K'.

After a period of time greater than 0.5 s but not exceeding 1 s, it shall be verified that a link test is transmitted also in the presence of transmission of ASK Up-link data.

For the acquisition performed in step 7, it shall be verified that the following is transmitted for a period of time not exceeding 1 s:

- b. Data and CLK signals comply with the requirements of UNISIG SUBSET-101 defined for "Eurobalise mode".

After a period of time greater than 0.5 s but not exceeding 1 s, it shall be verified that a link test is transmitted also in the presence of transmission of FSK Up-link data.

4.3.6 Verification of Transmission and Bit Stream Requirements

See section 4.2.6 on page 35.

The only modification applicable to this alternative 2 interface is that there is no distinguishing between 'Data for Balise Detection' and 'Data for Telegram Decoding' that is to be considered. There is only (safe) 'Data' in this interface, used for both Balise Detection and Telegram Decoding.

For the purpose of Transmission Test acceptance criteria (see section 4.2.6.4.3 on page 48, the following applies:

- Data is present during a sufficient period (as defined by UNISIG SUBSET-100)
- Data in Interface 'K' complies with the data transmitted in Interface 'G'

4.4 Requirements for Test Tools

See UNISIG SUBSET-085, and applicable annexes herein.

5 Tests of the STM

5.1 Reference Test Configuration

5.1.1 General

In order to observe the reaction of the STM upon introduction of abnormal conditions in the Interface 'K' data, company specific sequences shall be executed and the reaction of the STM shall be observed via the STM FFFIS.

5.1.2 Generic Test Set-up

The recommended general test set-up is shown in Figure 15 below. Annex E on page 134 gives an example of suitable test equipment.

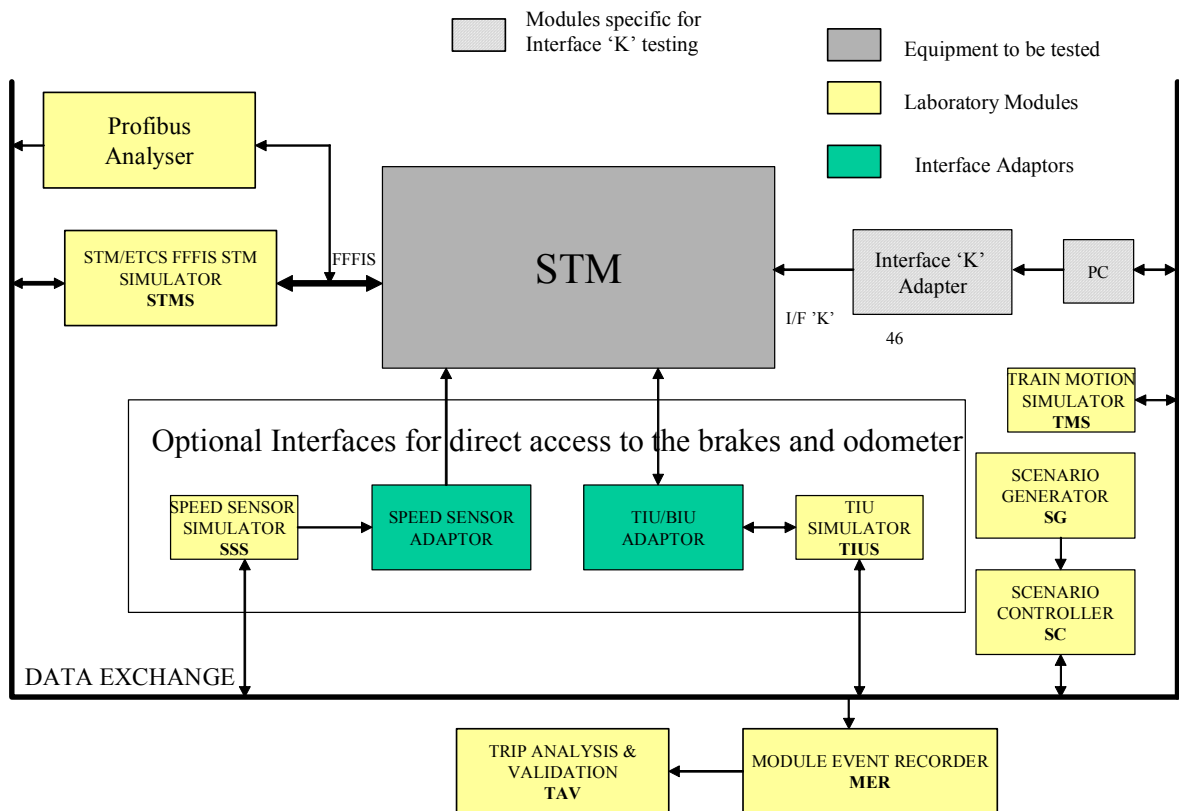

Figure 15: Generic Test set-up for STM tests

5.1.3 Generic Notes

1. The possible need for system specific start-up sequences in order to ensure defined state/mode of the STM is not dealt with in this specification.
2. The test set-up shown in Figure 15 on page 62 in general includes the entire test environment used for testing the STM functionality. This is defined by the UNISIG STM group and included in UNISIG SUBSET-074-1. Some modules are highlighted as “specific for Interface ‘K’ testing. These are required for enabling testing of the Interface ‘K’ functionality, are defined within this specification (SUBSET-102). The general STM test environment is not further dealt with in this specification.

5.1.4 Test Conditions

5.1.4.1 General

The nominal conditions defined in this section apply to all measurements unless otherwise explicitly stated.

5.1.4.2 Climatic Conditions

Ambient temperature: 25 °C ± 10 °C.

Relative humidity: 25 % to 75 %.

Atmospheric Pressure: 86 kPa to 106 kPa.

5.1.4.3 RS 485 Conditions

Nominal RS 485 conditions apply unless otherwise explicitly stated. The ASK data bit rate shall be the nominal data rate defined by UNISIG SUBSET-101. Likewise, for the alternative 1 interface, the Bi Phase Level (BPL) clock shall be set to its nominal behaviour defined by UNISIG SUBSET-101.

5.1.4.4 Time and Odometer Conditions

For the purpose of the STM tests defined herein, the velocity 100 km/h shall be used unless nothing else is specified.

5.1.4.5 Test Sequences and Telegram Content

In general, the details for the various sequences (such as suitable Balise messages, configuration of Balise Groups, etc.) are KER system dependent. Suitable sequences shall be defined by each STM manufacturer in order to be able prove the various aspect defined herein (i.e., to be able to run a sequence, and to be able to record a known and defined reaction). Most likely, there is a need for a system specific start-up sequence before the actual test sequences are executed in order to ensure that the system is in a known state/mode. Also this shall be defined by the STM manufacturer. Where applicable, the expected STM reaction time shall be defined by the manufacturer.

The need for system specific start-up sequences is not further dealt with in this specification (i.e., not mentioned in the specific test procedures).

The actual telegram content is dependent on the specific test procedures herein, but also dependent on the specific system in question. Further details related to what functionality is to be evaluated are defined in the various test procedures included in this chapter (chapter 5).

In general, the same data should simultaneously be transmitted at all involved channels (except the obvious differences in Link ID Data and CRC in the alternative 1 interface) unless explicitly otherwise defined.

When faulty signal is given to the STM over Interface 'K', the STM shall have an observable reaction within a defined time. The time is product specific, but shall not exceed the stipulated limit.

The observable reaction is product specific, but usable reactions are:

- The STM enters FA state
- The STM issues a Diagnostic message
- The STM gives specific indication to DMI (i.e., a text message about the failure condition)

5.1.5 Test Tools and Procedures

The following list summarises the herein-defined STM tests:

1. Electrical data
2. Data transmission
3. Timing requirements
4. Functional data
5. Link check functionality
6. Handling of diversified data
7. Detection of Balises
8. Management of side lobe effects
9. Telegram decoding

The following specific tools are anticipated for the STM tests:

- Interface 'K' adapter
- Interface 'STM' adapter

The Interface STM environment should for obvious reasons be available since it is anyway required for performing verification of the operational STM functionality. This device is specified on a functional basis by the STM group. Therefore this adapter is not within the scope of this specification. However, this test specification possibly demands some kind of synchronisation between the generation of certain sequences and the observation of the STM reaction. Such information should be communicated to the group in charge of specifying the Interface 'STM' adapter.

The Interface 'K' adapter is specifically required for enabling the execution of the tests defined herein. Therefore, this adapter is defined to a sufficient level of detail in order to facilitate designing such a tool. It should be observed that aspects on overall test time are crucial. A suitable block diagram is presented in Annex D herein.

5.2 Laboratory Tests, Alternative 1 Interface

5.2.1 Electrical Data

5.2.1.1 General, Electrical Data

This section outlines the tests needed for ensuring that the electrical data for Interface 'K' is fulfilled.

Since it is likely that commercially available receiver circuits are used, it is in such a case sufficient to ensure (show guarantees) that the actual device fulfils the applicable standard. Specifically developed receiver circuits must be fully characterised in order to show compliance with the applicable standard.

The principle above also applies to ensuring the defined isolation requirements.

The receiver shall be verified through applying worst case conditions according to the RS 485 standard at the input terminal of the receiver.

5.2.1.2 Conditions, Electrical Data

The maximum amount of loading receivers and (non active) transmitters shall be considered. See definitions in UNISIG SUBSET-101.

5.2.1.3 Acceptance Criteria, Electrical Data

- a. The limits defined by the RS 485 standard shall be fulfilled.
- b. The isolation requirements defined by the EN 50155 standard shall be fulfilled.

5.2.2 Data Transmission

Fulfilment of the basic requirements for ensuring correct data transmission is implicitly verified through the other tests of this chapter (chapter 5).

5.2.3 Timing Requirements

5.2.3.1 General Description, Timing Requirements

This section defines the test procedure for verifying the ability to cope with extreme timing requirements. The test procedures include verification of the following properties:

- Ability to cope with extreme ASK bit data rates
- Ability to cope with extreme phase difference between various channels
- Ability to cope with extreme jitter in the Bi Phase Level (BPL) clock generation
- Reaction on correct and incorrect number of stop bits

5.2.3.2 Test Pattern, Timing Requirements

The STM manufacturer shall define a suitable test sequence and test patterns such that correct handling of the imperfections in the parameters defined in section 5.2.3.1 is ensured.

If not explicitly otherwise defined, Link Test Data shall be transmitted on a regular basis according to UNISIG SUBSET-101 (i.e., link tests shall be performed in accordance with UNISIG SUBSET-101).

5.2.3.3 Test Procedure, Timing Requirements

1. Transmit the system specific test sequence with the Bi Phase Level (BPL) clock and ASK bit data rates in Interface 'K' set to the nominal value as defined by UNISIG SUBSET-101.
2. Observe the reaction of the STM via the STM FFFIS.
3. Set the ASK bit data rate in Interface 'K' to the lower extreme defined by UNISIG SUBSET-101, and transmit the system specific test sequence.
4. Observe the reaction of the STM via the STM FFFIS.
5. Set the ASK bit data rate in Interface 'K' to the upper extreme defined by UNISIG SUBSET-101, and transmit the system specific test sequence.
6. Observe the reaction of the STM via the STM FFFIS.
7. Set the BPL clock data rate in Interface 'K' such that only 23 stop bits are generated within the available 20 μ s period, and transmit the system specific test sequence.
8. Observe the reaction of the STM via the STM FFFIS (including the reaction time).
9. Set the BPL clock data rate in Interface 'K' such that 27 stop bits are generated within the available 20 μ s period, and transmit the system specific test sequence.
10. Observe the reaction of the STM via the STM FFFIS (including the reaction time).
11. Set the ASK bit data rate in Interface 'K' such that it is 50 % outside the lower tolerance in data rate as defined by UNISIG SUBSET-101, and transmit the system specific test sequence.
12. Observe the reaction of the STM via the STM FFFIS (including the reaction time).
13. Set the ASK bit data rate in Interface 'K' such that it is 50 % outside the upper tolerance in data rate as defined by UNISIG SUBSET-101, and transmit the system specific test sequence.
14. Observe the reaction of the STM via the STM FFFIS (including the reaction time).
15. Set the jitter in the Bi Phase Level (BPL) clock to the upper extreme defined by UNISIG SUBSET-101, and transmit the system specific test sequence.
16. Observe the reaction of the STM via the STM FFFIS.

The above steps shall be performed simultaneously transmitting the defined data rates at all channels. Furthermore:

17. Simulate, as case one, the maximum allowed phase difference between channel a and channel b, and as case two, the maximum allowed phase difference between channel c and channel d as defined in UNISIG SUBSET-101.
18. Observe the reaction of the STM via the STM FFFIS.

5.2.3.4 Acceptance Criteria, Timing Requirements

For each of the steps 2, 4, 6, 16, and 18, it shall be verified that the STM continues to operate without loss of performance.

For each of the steps 8, 10, 12, and 14, verify that the manufacturer dependent reaction is obtained within the stipulated reaction time.

5.2.4 Functional Data

5.2.4.1 General Description, Functional Data

This section defines the test procedure for verifying the correct reaction on data from a functional perspective. The test procedure includes verification of the following properties:

- Reaction on 'Data for Balise Detection' (BD)
- Reaction on 'Data for Telegram Decoding' (TD)
- Reaction on 'ERTMS Unavailability' (EU)
- Reaction on 'Eurobalise Reception' (EB) upon reception of Eurobalises
- Reaction on 'Link Test Data' (LT)
- Reaction on 'Signal Strength Data' (S)
- Reaction on 'Antenna/BTM ID Data' (A)
- Reaction on 'Link ID Data' (L)
- Reaction on 'Bit Counter Data' (B)
- Reaction on incorrect CRC

The requirements related to diversified data defined in UNISIG SUBSET-101 will also be verified from a receiver perspective. Finally, simulation of the Interface 'K' link set to inactive (no BPL coding), indicating permanently failing BTM functionality, is also simulated in order to verify that the STM correctly copes with such a situation.

Definitions of the acronyms used herein are found in UNISIG SUBSET-101.

5.2.4.2 Test Pattern, Functional Data

The STM manufacturer shall define a suitable test sequence and test patterns such that the correct behaviour with respect to the data defined in section 5.2.4.1 is ensured.

If not explicitly otherwise defined, Link Test Data shall be transmitted on a regular basis according to UNISIG SUBSET-101 (i.e., link tests shall be performed in accordance with UNISIG SUBSET-101).

If otherwise not explicitly mentioned in the test procedure, it is assumed that a correctly operative sequence without imperfections is transmitted, where BD and TD data is identical. Deviations from this condition (e.g., introduction of failure conditions) are explicitly defined.

5.2.4.3 Test Procedure, Functional Data

1. Transmit the correct sequence.
2. Observe the reaction of the STM via the STM FFFIS.
3. For at least one of the Balise passages, introduce differences between BD and TD data. The differences shall be such that TD data is correct and that BD data still does not jeopardise the Balise Detect criteria (i.e., that there is a higher percentage of 'zeros' in BD data than in TD data).
4. Observe the reaction of the STM via the STM FFFIS.
5. For at least one of the Balise passages, introduce differences between BD and TD data. The differences shall be such that TD data is not correct but that BD data is correct (creating Balise Detect).
6. Observe the reaction of the STM via the STM FFFIS.
7. Introduce at least one additional Balise marked as Eurobalise (using the EB data).
8. Observe the reaction of the STM via the STM FFFIS.
9. Occasionally discontinue the transmission of repetitive link checks such that UNISIG SUBSET-101 is violated in this respect.
10. Observe the reaction of the STM via the STM FFFIS.
11. Occasionally transmit link checks where LT data is set to logical 'one' for a period of time violating the requirements of UNISIG SUBSET-101.
12. Observe the reaction of the STM via the STM FFFIS.
13. Introduce transmission of a long correct Balise passage (e.g., 2 s), and ensure that a correct link test is introduced 1 s after the start of the Balise (thus temporarily interrupting transmission of Balise data).
14. Observe the reaction of the STM via the STM FFFIS.
15. Simulate that Tele-powering is erroneously switched off (using EU data) for a period of time sufficient for detection.
16. Observe the reaction of the STM via the STM FFFIS.
17. Transmit the correct sequence, and ensure that S data is set to 'zero' all the time.
18. Observe the reaction of the STM via the STM FFFIS.
19. Transmit the correct sequence, and ensure that S data is representing realistic lobe characteristics for all Balise passages.
20. Observe the reaction of the STM via the STM FFFIS.
21. Simulate that the source of data is erroneous (using erroneous A data) for a period of time sufficient for detection (i.e., for more than 10 ASK bits during a period of time corresponding to 100000 ASK bits).
22. Observe the reaction of the STM via the STM FFFIS.
23. Simulate that the data is transmitted on a non intended link (using erroneous L data) for a period of time sufficient for detection (i.e., for more than 10 ASK bits during a period of time corresponding to 100000 ASK bits).
24. Observe the reaction of the STM via the STM FFFIS.
25. Simulate that the bit counter data is not consecutive (using erroneous B data) for a period of time sufficient for detection.
26. Observe the reaction of the STM via the STM FFFIS.
27. Simulate that the CRC is corrupted for a period of time sufficient for detection during a Balise passage (i.e., for more than 10 ASK bits during a period of time corresponding to 100000 ASK bits).

28. Observe the reaction of the STM via the STM FFFIS.
29. Set the Interface 'K' channel to absence of activity (including no Bi Phase Level (BPL) coding) and observe the reaction of the STM via the STM FFFIS.

The above steps shall be performed simultaneously transmitting the same data at all involved channels (except for step 29, where one single link shall be tested at a time and the obvious difference in Link ID Data). Furthermore:

30. Transmit the correct sequence in one channel, and introduce in at least one Balise passage that neither BD nor TD data is obtained in the other channel (no Balise Detect and no telegram).
31. Observe the reaction of the STM via the STM FFFIS.
32. Transmit the correct sequence in one channel, and introduce in at least one Balise passage with corrupted TD data in the other channel (but still Balise Detect).
33. Observe the reaction of the STM via the STM FFFIS.
34. Transmit the correct sequence in one channel, and introduce in at least one Balise passage that the Balise is marked as Eurobalise in the other channel (using the EB data).
35. Observe the reaction of the STM via the STM FFFIS.
36. Transmit the correct sequence in one channel, and introduce discontinued transmission of repetitive link checks in the other channel.
37. Observe the reaction of the STM via the STM FFFIS.
38. Transmit the correct sequence in one channel, and introduce transmission of link tests where LT data is set to logical 'one' for a period of time violating the requirements of UNISIG SUBSET-101 in the other channel.
39. Observe the reaction of the STM via the STM FFFIS.
40. Transmit the correct sequence in one channel, and introduce for a period of time sufficient for detection that Tele-powering is erroneously switched off in the other channel (using EU data).
41. Observe the reaction of the STM via the STM FFFIS.
42. Transmit the correct sequence, and in one channel ensure that S data is set to 'zero' all the time. In the other channel, it shall be ensured that S data is representing realistic lobe characteristics for all Balise passages.
43. Observe the reaction of the STM via the STM FFFIS.
44. Transmit the correct sequence in one channel, and introduce for a period of time sufficient for detection that the source of data is erroneous in the other channel (using erroneous A data).
45. Observe the reaction of the STM via the STM FFFIS.
46. Transmit the correct sequence in one channel, and introduce for a period of time sufficient for detection that data is transmitted via a non intended link in the other channel (using erroneous L data).
47. Observe the reaction of the STM via the STM FFFIS.
48. Transmit the correct sequence in one channel, and introduce an inconsistency in the bit counter of the other channel (using erroneous B data).
49. Observe the reaction of the STM via the STM FFFIS.
50. Transmit the correct sequence in one channel, and introduce during a Balise passage, for a period of time sufficient for detection, that CRC is corrupted in the other channel.
51. Observe the reaction of the STM via the STM FFFIS.

The steps from step 30 until the end shall be repeated such that the abnormalities in the sequences are applied to one channel at a time (while the others have normal conditions).

5.2.4.4 Acceptance Criteria, Functional Data

The following shall be verified via the STM FFFIS:

- Step 2 The STM continues to operate without loss of performance.
- Step 4 The STM continues to operate without loss of performance.
- Step 6 The STM detects all Balises, and detects the situation with loss of telegram. Verify that the manufacturer dependent reaction is obtained within the stipulated reaction time.
- Step 8 The STM continues to operate without loss of performance.
- Step 10 The STM detects that link checks are missing. Verify that the manufacturer dependent reaction is obtained within the stipulated reaction time.
- Step 12 The STM detects that link checks are too long. Verify that the manufacturer dependent reaction is obtained within the stipulated reaction time.
- Step 14 The STM continues to operate without loss of performance.
- Step 16 The STM detects that ERMS is unavailable. Verify that the manufacturer dependent reaction is obtained within the stipulated reaction time.
- Step 18 The STM continues to operate without loss of performance.
- Step 20 The STM continues to operate without loss of performance.
- Step 22 The STM detects that data is sent from a non intended source. Verify that the manufacturer dependent reaction is obtained within the stipulated reaction time.
- Step 24 The STM detects that data is sent via a non intended link. Verify that the manufacturer dependent reaction is obtained within the stipulated reaction time.
- Step 26 The STM detects that bit counter data is not consecutive. Verify that the manufacturer dependent reaction is obtained within the stipulated reaction time.
- Step 28 The STM detects that CRC is corrupted. Verify that the manufacturer dependent reaction is obtained within the stipulated reaction time.
- Step 29 The STM detects that Interface 'K' is not active. Verify that the manufacturer dependent reaction is obtained within the stipulated reaction time.
- Step 31 The STM detects all Balises, and detects the situation with loss of telegram. Verify that the manufacturer dependent reaction is obtained within the stipulated reaction time.
- Step 33 The STM continues to operate without loss of performance.
- Step 35 The STM continues to operate without loss of performance.
- Step 37 The STM detects that link checks are missing. Verify that the manufacturer dependent reaction is obtained within the stipulated reaction time.
- Step 39 The STM detects that link checks are too long. Verify that the manufacturer dependent reaction is obtained within the stipulated reaction time.

- Step 41 The STM detects that ERTMS is not available. Verify that the manufacturer dependent reaction is obtained within the stipulated reaction time.
- Step 43 The STM continues to operate without loss of performance.
- Step 45 The STM detects that data is sent from a non intended source. Verify that the manufacturer dependent reaction is obtained within the stipulated reaction time.
- Step 47 The STM detects that data is sent via a non intended link. Verify that the manufacturer dependent reaction is obtained within the stipulated reaction time.
- Step 49 The STM detects that the bit counter is erroneous. Verify that the manufacturer dependent reaction is obtained within the stipulated reaction time.
- Step 51 The STM detects that CRC is corrupted. Verify that the manufacturer dependent reaction is obtained within the stipulated reaction time.

5.2.5 Link Check Functionality

5.2.5.1 General Description, Link Check Functionality

This section defines the test procedure for verifying the correct reaction on signals used for on-line supervision of the Interface 'K' link. The test procedure includes verification of the following properties:

- Correct reaction on link check pattern

5.2.5.2 Test Pattern, Link Check Functionality

The STM manufacturer shall define a suitable test sequence and test patterns such that correct behaviour with respect to the data defined in section 5.2.5.1 is ensured.

No Balise passages shall be simulated (unless the possible initial sequence required for setting the system in a define state/mode), and the time between successive link checks shall be set to 200 ms.

5.2.5.3 Test Procedure, Link Check Functionality

1. Transmit the correct link check pattern.
2. Observe the reaction of the STM via the STM FFFIS.
3. Transmit a link check pattern according to SUBSET-101, but with correct CRC in bit two.
4. Observe the reaction of the STM via the STM FFFIS.
5. Transmit a link check pattern according to SUBSET-101, but with corrupted CRC in bit one.
6. Observe the reaction of the STM via the STM FFFIS.
7. Transmit a link check pattern according to SUBSET-101, but with inverted BD data in all bits.
8. Observe the reaction of the STM via the STM FFFIS.
9. Transmit a link check pattern according to SUBSET-101, but with inverted TD data in all bits.
10. Observe the reaction of the STM via the STM FFFIS.
11. Transmit a link check pattern according to SUBSET-101, but with inverted EU data in all bits.
12. Observe the reaction of the STM via the STM FFFIS.
13. Transmit a link check pattern according to SUBSET-101, but with inverted EB data in all bits.
14. Observe the reaction of the STM via the STM FFFIS.
15. Transmit a link check pattern according to SUBSET-101, but with inverted S data in all bits.
16. Observe the reaction of the STM via the STM FFFIS.
17. Transmit a link check pattern according to SUBSET-101, but with inverted A data in all bits.
18. Observe the reaction of the STM via the STM FFFIS.
19. Transmit a link check pattern according to SUBSET-101, but with inverted L data in all bits.
20. Observe the reaction of the STM via the STM FFFIS.

5.2.5.4 Acceptance Criteria, Link Check Functionality

The following shall be verified via the STM FFFIS:

Step 2	The STM continues to operate without loss of performance.
Steps 4, 6, 8, 10, 12, 14, 16, 18, and 20	The STM detects that link checks are either missing or corrupt. Verify that the manufacturer dependent reaction is obtained within the stipulated reaction time.

In case of several channels, the STM shall detect if a failure condition is occurring in any single channel.

5.2.6 Handling of Diversified Data

Fulfilment of the basic requirements for ensuring correct handling of diversified data is verified through the tests included in section 5.2.4 on page 69.

5.2.7 Detection of Balises

5.2.7.1 General Description, Detection of Balises

This section defines the test procedure for verifying that the STM has the capability to detect a Balise during worst case conditions in the amount of received bits (i.e., the shortest allowed sequence of bits above the vital threshold in the On-board Transmission Equipment).

Since it is the responsibility of the STM to consider the actual coding requirements for the specific system, tailoring of the length of sequence is required specifically for each system. This means that the minimum contact distance defined in UNISIG SUBSET-100 shall be shortened by the time corresponding to the maximum amount of consecutive 'ones' that the specific coding strategy allows. It is also the responsibility of the STM supplier to consider potential STM specific margins when tailoring of the length of the sequence.

5.2.7.2 Test Pattern, Detection of Balises

The STM manufacturer shall define a suitable test sequence and test patterns such that correct behaviour with respect to the data defined in section 5.2.7.1 is ensured.

Link Test Data shall be transmitted on a regular basis according to UNISIG SUBSET-101 (i.e., link checks shall be performed in accordance with UNISIG SUBSET-101).

Please observe that for some systems, the required number of bits may be dependent on the speed determined by the Time and Odometer information. A relevant number of test points (with respect to velocity) shall in such cases be defined by the supplier of the STM.

5.2.7.3 Test Procedure, Detection of Balises

1. Transmit a sequence where the BD and TD data is correct for all Balises and chosen such that the minimum required contact length for Balise Detect is simulated.
2. Observe the reaction of the STM via the STM FFFIS.
3. Transmit a sequence where the BD is correct for all Balises and chosen such that the minimum required contact length for Balise Detect is simulated. Regarding TD data, this shall for at least one Balise passage be set to logical 'one' (i.e., no telegram).
4. Observe the reaction of the STM via the STM FFFIS.

5.2.7.4 Acceptance Criteria, Detection of Balises

The following shall be verified via the STM FFFIS:

- | | |
|--------|--|
| Step 2 | The STM either continues to operate without loss of performance or only detects the Balises (dependent on relation between requirements on Balise Detect and telegram decoding). |
| Step 4 | The STM detects all Balises, and detects the situation with loss of telegram. Verify that the manufacturer dependent reaction is obtained within the stipulated reaction time. |

5.2.8 Management of Side Lobe Effects

5.2.8.1 General Description, Management of Side Lobe Effects

This section defines the test procedure for verifying the correct reaction in the presence of various side lobe conditions. The test procedure includes verification of the following properties:

- Handling of side lobes positioned at various distances from the main lobe
- Handling of telegram shift in combination with side lobes
- Handling of side lobes when no telegram decoding is possible
- Handling of signal strength data for the purpose of side lobe identification
- Handling of multiple side lobes
- Behaviour when restrictive aspect messages are transmitted

In general, all test cases should be designed such that the specific properties detailed herein are put in a wider context in order to constitute meaningful system specific information that can be handled by the STM (and a relevant reaction can be observed). It is the responsibility of the STM manufacturer to define the needed details. It should be observed that the specifics in the patterns aiming at verifying the side lobe handling properties shall be such that it is possible to positively identify the reaction (e.g., unique telegrams shall be used in various lobes unless explicitly stated to be identical, and these shall be selected such that different system reactions are obtained if the reaction is observed on system level).

Telegram contents indicated herein (T1, T2, etc.) are system specific, and need to be defined by the STM manufacturer. The indications on indicated telegram contents are not global (i.e., T1 in one test case may be different from T1 in another test case).

If it is found suitable, a specific test interface may be implemented on the STM. Via such a test interface, detailed reporting on selection of lobes and telegram contents may be provided (rather than observing system oriented reactions via the STM FFFIS). If a specific test interface is adopted, the manufacturer shall through specific verifications prove that the test interface response is correlated with the operational STM algorithms

5.2.8.2 Test Pattern, Management of Side Lobe Effects

5.2.8.2.1 General

The STM manufacturer shall define suitable test sequences and test patterns such that the correct behaviour with respect to the mechanisms defined in section 5.2.8.1 is ensured.

Link Test Data shall be transmitted on a regular basis according to UNISIG SUBSET-101 (i.e., link tests shall be performed in accordance with UNISIG SUBSET-101).

It is in general assumed that a correctly operative sequence without imperfections is transmitted unless otherwise explicitly defined. BD and TD data is assumed to be identical, but in some cases data may not constitute correct telegram information (i.e., it is not possible to decode the data according the applicable coding strategy).

5.2.8.2.2 Definitions

In general, lobes with the following general characteristics shall be generated. The shown lobes represent the amplitude information. Regarding BD/TD data, this is transmitted according to telegram information during the entire lobes (L1, L2, and L3).

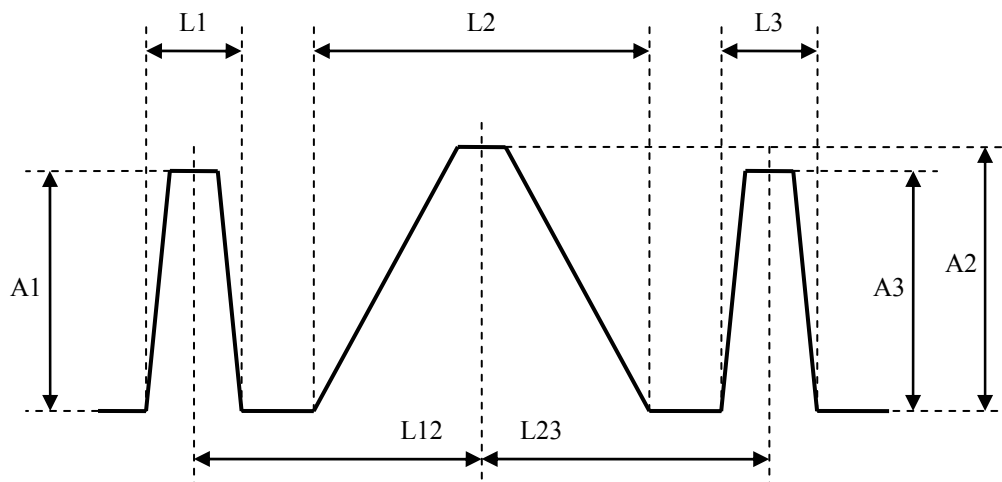

Figure 16: General shape of lobes, Alternative 1

The following applies to the parameters in Figure 16 for the test cases defined in section 5.2.8.2.3 on page 82. The aim is to systematically verify that STM concludes in accordance with the requirement matrix included in UNISIG SUBSET-101.

- The peak amplitude of the first and the third lobes (A1 and A3 respectively) shall be equal and correspond to the signal strength information 1011 (MSB...LSB).
- The peak amplitude of the second lobe (A2) shall correspond to the signal strength information 1100 (MSB...LSB).
- The width of the first and the third lobes (L1 and L3 respectively) shall be equal and correspond to 0.3 m.
- The width of the second lobe (L2) shall correspond to 0.5 m.
- The distance between the mid points of the lobes, L12 and L23 respectively, shall be equal and in accordance with the various test cases defined in section 5.2.8.2.3 on page 82.
- During the simulation of the lobes according to Figure 16, the speed 100 km/h shall be used.
- The telegram contents transmitted during the lobes (TD Data) are hereafter referred to as T1, T2, and T3 respectively for the three lobes. In the general test cases (section 5.2.8.2.3 on page 82) it is assumed that when identical telegrams are chosen, they do not constitute data consistent with possible Balise group configuration (this is separately dealt with in a specific test case in section 5.2.8.2.4 on page 83).
- The rising and falling edges of the simulated lobes shall be such that the length of the flat peak level is 0.4 ms for all lobes.

For the purpose of verifying handling of signal strength data (test cases 201 through 209 in section 5.2.8.2.4 on page 83), the following applies. The aim is to verify that the STM correctly handles signal strength data (when available) and makes the correct decision on main lobe with a side lobe before the main lobe.

- The third lobe shall not be generated ($L3 = 0$)
- The peak amplitude of the first lobe (A1) shall correspond to the signal strength information 1011 (MSB...LSB).
- The peak amplitude of the second lobe (A2) shall correspond to the signal strength information 1100 (MSB...LSB).
- The width of the first lobe (L1) shall correspond to 0.5 m.
- The width of the second lobe (L2) shall correspond to 0.3 m.
- The distance between the mid points of the lobes, L12, shall be in accordance with the various test cases defined in section 5.2.8.2.4 on page 83 (test cases 201 through 209).
- During the simulation of the lobes according to Figure 16, the speed 100 km/h shall be used.
- The telegram contents transmitted during the lobes (TD Data) are hereafter referred to as T1 and T2 respectively for the two lobes.
- The rising and falling edges of the simulated lobes shall be such that the length of the flat peak level is 0.4 ms for all lobes.

For the purpose of verifying handling of signal strength data (test cases 601 through 609 in section 5.2.8.2.4 on page 83), the following applies. The aim is to verify that the STM correctly handles signal strength data (when available) and makes the correct decision on main lobe with a side lobe after the main lobe.

- The first lobe shall not be generated ($L1 = 0$)
- The peak amplitude of the third lobe (A3) shall correspond to the signal strength information 1011 (MSB...LSB).
- The peak amplitude of the second lobe (A2) shall correspond to the signal strength information 1100 (MSB...LSB).
- The width of the third lobe (L3) shall correspond to 0.5 m.
- The width of the second lobe (L2) shall correspond to 0.3 m.
- The distance between the mid points of the lobes, L23, shall be in accordance with the various test cases defined in section 5.2.8.2.4 on page 83 (test cases 601 through 609).
- During the simulation of the lobes according to Figure 16, the speed 100 km/h shall be used.
- The telegram contents transmitted during the lobes (TD Data) are hereafter referred to as T2 and T3 respectively for the two lobes.
- The rising and falling edges of the simulated lobes shall be such that the length of the flat peak level is 0.4 ms for all lobes.

For the purpose of verifying handling of signal strength data over the entire dynamic range (test cases 701 through 702 in section 5.2.8.2.4 on page 83), the following applies. The aim is to verify that the STM correctly handles signal strength data (when available) and makes the correct decision on main lobe with a side lobe after the main lobe.

- The first lobe shall not be generated ($L1 = 0$)
- The peak amplitude of the third lobe (A3) shall in a row of consecutive tests correspond to the signal strength information 0001 (MSB...LSB) through 1110. The signal strength information shall be correlated with the peak amplitude of the second lobe (A2) such that it for all tests is 1 LSB less than A2.
- The peak amplitude of the second lobe (A2) shall in a row of consecutive tests correspond to the signal strength information 0010 (MSB...LSB) through 1111. The signal strength information shall be correlated with the peak amplitude of the third lobe (A3) such that it for all tests is 1 LSB more than A3.
- The width of the third lobe (L3) shall correspond to 0.5 m.
- The width of the second lobe (L2) shall correspond to 0.3 m.
- The distance between the mid points of the lobes, L23, shall be in accordance with the various test cases defined in section 5.2.8.2.4 on page 83 (test cases 701 through 702).
- During the simulation of the lobes according to Figure 16, the speed 100 km/h shall be used.
- The telegram contents transmitted during the lobes (TD Data) are hereafter referred to as T2 and T3 respectively for the two lobes.
- The rising and falling edges of the simulated lobes shall be such that the length of the flat peak level is 0.4 ms for all lobes.

For the specific case that identical telegrams are chosen such that they constitute data consistent with possible Balise group configuration (test cases 401 through 403 in section 5.2.8.2.4 on page 83), the following applies:

- The third lobe shall not be generated ($L3 = 0$)
- The peak amplitude of the first lobe (A1) shall correspond to the signal strength information 1011 (MSB...LSB).
- The peak amplitude of the second lobe (A2) shall correspond to the signal strength information 1100 (MSB...LSB).
- The width of the first lobe (L1) shall correspond to 0.5 m.
- The width of the second lobe (L2) shall correspond to 0.3 m.
- The distance between the mid points of the lobes, L12, shall be in accordance with the various test cases defined in section 5.2.8.2.4 on page 83 (test cases 401 through 403).
- During the simulation of the lobes according to Figure 16, the speed 100 km/h shall be used.
- The telegram contents transmitted during the lobes (TD Data) are hereafter referred to as T1 and T2 respectively for the two lobes. It is assumed that identical telegrams are chosen such that they constitute data consistent with possible Balise group.
- The rising and falling edges of the simulated lobes shall be such that the length of the flat peak level is 0.4 ms for all lobes.

The above also applies to testing the behaviour when the first lobe includes transmission of a restrictive aspect message (test case 501 in section 5.2.8.2.3 on page 82).

For the purpose of verifying handling of multiple side lobes, the following characteristics shall be generated. The shown lobes represent the amplitude information. Regarding BD/TD data, this is transmitted according to telegram information during the entire lobes (L1, L2, L3, and L4).

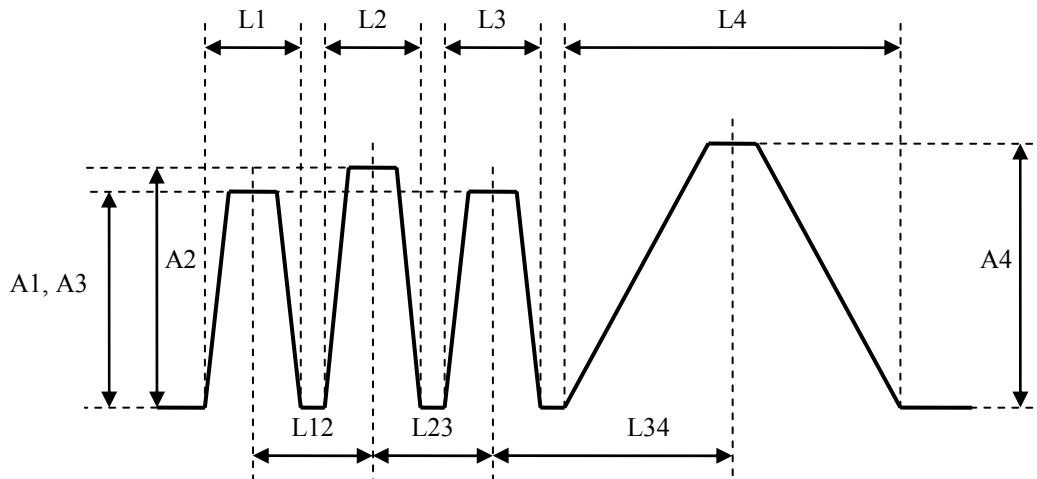

Figure 17: Shape of multiple side lobes, Alternative 1

For the purpose of verifying handling of multiple side lobes (test cases 301 through 309 in 5.2.8.2.4 on page 83), the following applies:

- The peak amplitude of the first and third lobes (A1 and A3 respectively) shall be equal and correspond to the signal strength information 1010 (MSB...LSB).
- The peak amplitude of the second lobe (A2) shall correspond to the signal strength information 1011 (MSB...LSB).
- The peak amplitude of the fourth lobe (A4) shall correspond to the signal strength information 1100 (MSB...LSB).
- The width of the first lobe (L1) shall correspond to 0.15 m.
- The width of the second lobe (L2) shall correspond to 0.20 m.
- The width of the third lobe (L3) shall correspond to 0.25 m.
- The width of the fourth lobe (L4) shall correspond to 0.4 m.
- The distance between the mid points of the first three lobes, L12 and L23 respectively, shall be 0.25 m and the distance between the third and the fourth lobe, L34, shall be in accordance with the various test cases defined in section 5.2.8.2.4 on page 83 (test cases 301 through 309).
- During the simulation of the lobes according to Figure 17, the speed 50 km/h shall be used.
- The telegram contents transmitted during the lobes (TD Data) are hereafter referred to as T1, T2, T3, and T4 respectively for the four lobes. It is assumed that when identical telegrams are chosen, they do not constitute data consistent with possible Balise group configuration.
- The rising and falling edges of the simulated lobes shall be such that the length of the flat peak level is 0.4 ms for all lobes.

5.2.8.2.3 General Test Cases

For systems having a coding strategy such that it includes dedicated variables that can be used for determining if different telegrams belong to the same Balise or to two different Balises (e.g., Ebicab 900), the following apply. See also Figure 16 of section 5.2.8.2.2 on page 78 and the corresponding definitions.

L12 T	0.5 m	1.0 m	2.0 m
Different telegrams indicate different Balises. T1 ≠ T2, T2 = T3	TC1	TC2	TC3
Different telegrams indicate different Balises. T1 = T2, T2 ≠ T3	TC4	TC5	TC6
Different telegrams indicate different Balises. T1 ≠ T2, T2 ≠ T3, T1 ≠ T3	TC7	TC8	TC9
T1 = T2 = T3	TC10	TC11	TC12
Different telegrams indicate same Balise. T1 ≠ T2, T2 = T3	TC13	TC14	TC15
Different telegrams indicate same Balise. T1 = T2, T2 ≠ T3	TC16	TC17	TC18
Different telegrams indicate same Balise. T1 ≠ T2, T2 ≠ T3, T1 ≠ T3	TC19	TC20	TC21
Corrupted telegram in the first lobe, T2 = T3	TC22	TC23	TC24
Corrupted telegram in the second lobe, T1 = T3	TC25	TC26	TC27
Corrupted telegram in the third lobe, T1 = T2	TC28	TC29	TC30
Corrupted telegram in all lobes.	TC31	TC32	TC33

Table 1: Test Cases when telegram content confirms Balise identity

For systems having a coding strategy and situations such that it is not possible to determine if different telegrams belong to the same Balise or to two different Balises, the following apply. See also Figure 16 of section 5.2.8.2.2 on page 78 and the corresponding definitions.

L12 T	0.5 m	1.0 m	2.0 m
T1 ≠ T2, T2 = T3	TC101	TC102	TC103
T1 = T2, T2 ≠ T3	TC104	TC105	TC106
T1 ≠ T2, T2 ≠ T3, T1 ≠ T3	TC107	TC108	TC109
T1 = T2 = T3	TC110	TC111	TC112
Corrupted telegram in the first lobe, T2 = T3	TC113	TC114	TC115
Corrupted telegram in the second lobe, T1 = T3	TC116	TC117	TC118
Corrupted telegram in the third lobe, T1 = T2	TC119	TC120	TC121
Corrupted telegram in all lobes.	TC122	TC123	TC124

Table 2: Test Cases when telegram content does not confirm Balise identity

The test cases according to Table 1 or Table 2 shall be repeated both with and without provision of signal strength data.

5.2.8.2.4 Specific Test Cases

For the purpose of testing that the signal strength data is correctly handled when a side lobe is preceding the main lobe, the following test cases shall be applied. See also Figure 16 of section 5.2.8.2.2 on page 78 and the corresponding definitions.

L12 T	0.5 m	1.0 m	2.0 m
Corrupted telegram in the first lobe	TC201	TC202	TC203
Corrupted telegram in the second lobe	TC204	TC205	TC206
Corrupted telegram in all lobes.	TC207	TC208	TC209

Table 3: Test Cases for testing handing of signal strength data

The test cases according to Table 3 shall be repeated both with and without the provision of signal strength data.

For the purpose of testing that multiple side lobes are correctly handled, the following test cases shall be applied. See also Figure 17 of section 5.2.8.2.2 on page 78 and the corresponding definitions.

L34 T	0.5 m	1.0 m	2.0 m
T1 = T2 = T3 =T4	TC301	TC302	TC303
Corrupted telegram in the first three lobes	TC304	TC305	TC306
Corrupted telegram in all lobes.	TC307	TC308	TC309

Table 4: Test Cases for testing handing of multiple side lobes

It is assumed that identical telegrams are chosen such that they do not constitute data consistent with possible Balise group configuration.

The test cases according to Table 4, shall be repeated both with and without the provision of signal strength data.

For the purpose of testing the behaviour when identical telegrams are consistent with a possible Balise group configuration, the following test cases shall be applied. See also Figure 16 of section 5.2.8.2.2 on page 78 and the corresponding definitions.

L12 T	0.5 m	1.0 m	2.0 m
T1 = T2	TC401	TC402	TC403

Table 5: Test Cases for testing handing consistent Balise group data

It is assumed that the telegrams are chosen such that they constitute data consistent with possible Balise group configuration.

The test cases according to Table 5 shall be repeated both with and without the provision of signal strength data.

For the purpose of testing the behaviour when a restrictive aspect message is transmitted in the first lobe, the following test case shall be applied. See also Figure 16 of section 5.2.8.2.2 on page 78 and the corresponding definitions.

L12	0.5 m	1.0 m	2.0 m
T			
T1 = Restrictive aspect message, T2 = normal message	TC501	-	-

Table 6: Test Cases for testing handing restrictive aspect message

Please observe that this test case must be designed such that the STM recognises that the information is relevant for the selected travelling direction.

The test cases according to Table 6 shall be repeated both with and without the provision of signal strength data.

For the purpose of testing that the signal strength data is correctly handled when a side lobe is succeeding the main lobe, the following test cases shall be applied. See also Figure 16 of section 5.2.8.2.2 on page 78 and the corresponding definitions.

L23	0.5 m	1.0 m	2.0 m
T			
Corrupted telegram in the second lobe	TC601	TC602	TC603
Corrupted telegram in the third lobe	TC604	TC605	TC606
Corrupted telegram in all lobes.	TC607	TC608	TC609

Table 7: Test Cases for testing handing of signal strength data

The test cases according to Table 7 shall be repeated both with and without the provision of signal strength data.

For the purpose of testing that the signal strength data is correctly handled over the entire dynamic range when a side lobe is succeeding the main lobe, the following test cases shall be applied. Please observe that each test case involves exploring all possible signal strength levels. See also Figure 16 of section 5.2.8.2.2 on page 78 and the corresponding definitions.

L23	0.5 m	1.0 m	2.0 m
T			
Corrupted telegram in the third lobe	TC701	TC702	-

Table 8: Test Cases for testing handing of signal strength data

The test cases according to Table 8 shall be repeated both with and without the provision of signal strength data.

5.2.8.3 Test Procedure, Management of Side Lobe Effects

The test patterns defined in section 5.2.8.2 on page 77 shall be generated and transmitted to the STM via Interface 'K'.

Test cases according to either Table 1 or Table 2, or both, shall be performed (dependent on the applicable coding strategy and relevant situations). All cases (including those in Table 1 through Table 7) shall be performed both with and without provision of signal strength data.

The resulting reaction of the STM shall be observed via the STM FFFIS, or via an explicit test interface (if available), and be verified to comply with the acceptance criteria defined in section 5.2.8.4 on page 85.

Link Test Data shall be transmitted on a regular basis outside the Balise contact volume according to UNISIG SUBSET-101.

5.2.8.4 Acceptance Criteria, Management of Side Lobe Effects

The following acceptance criteria apply to the test cases defined in section 5.2.8.2 on page 77.

When it is stated "report" in the table below, the meaning is that the information is either explicitly provided via a suitable test interface, or that the defined evaluation is indicated as part of an overall context (system level oriented reaction).

Case	With amplitude data	Without amplitude data
TC1	Report T1 as one Balise and T2 from the main lobe as another Balise.	Report T1 as one Balise and T2 from the main lobe as another Balise.
TC2	Report T1 as one Balise and T2 from the main lobe as another Balise.	Report T1 as one Balise and T2 from the main lobe as another Balise.
TC3	Report T1, T2, and T3 as three separate Balises.	Report T1, T2, and T3 as three separate Balises.
TC4	Report T2 from the main lobe as one Balise and T3 as another Balise.	Report T2 from the main lobe as one Balise and T3 as another Balise.
TC5	Report T2 from the main lobe as one Balise and T3 as another Balise.	Report T2 from the main lobe as one Balise and T3 as another Balise.
TC6	Report T1, T2, and T3 as three separate Balises.	Report T1, T2, and T3 as three separate Balises.
TC7	Report T1, T2, and T3 as three separate Balises.	Report T1, T2, and T3 as three separate Balises.
TC8	Report T1, T2, and T3 as three separate Balises.	Report T1, T2, and T3 as three separate Balises.
TC9	Report T1, T2, and T3 as three separate Balises.	Report T1, T2, and T3 as three separate Balises.
TC10	Report T2 from the main lobe as one Balise.	Report T2 from the main lobe as one Balise.
TC11	Report T2 from the main lobe as one Balise.	Report T2 from the main lobe as one Balise.
TC12	Report T1, T2, and T3 as three separate Balises.	Report T1, T2, and T3 as three separate Balises.

Case	With amplitude data	Without amplitude data
TC13	Report T2 from the main lobe as one Balise.	Report T2 from the main lobe as one Balise.
TC14	Report T2 from the main lobe as one Balise.	Report T2 from the main lobe as one Balise.
TC15	Report T2 from the main lobe as one Balise and T3 as another Balise.	Report T2 from the main lobe as one Balise and T3 as another Balise.
TC16	Report T2 from the main lobe as one Balise.	Report T2 from the main lobe as one Balise.
TC17	Report T2 from the main lobe as one Balise.	Report T2 from the main lobe as one Balise.
TC18	Report T1 as one Balise and T2 from the main lobe as another Balise.	Report T1 as one Balise and T2 from the main lobe as another Balise.
TC19	Report T2 from the main lobe as one Balise.	Report T2 from the main lobe as one Balise.
TC20	Report T2 from the main lobe as one Balise.	Report T2 from the main lobe as one Balise.
TC21	Report T2 from the main lobe as one Balise.	Report T2 from the main lobe as one Balise.
TC22	Report T2 from the main lobe as one Balise.	Report T2 from the main lobe as one Balise.
TC23	Report corrupted telegram as one Balise and T2 from the main lobe as another Balise.	Report corrupted telegram as one Balise and T2 from the main lobe as another Balise.
TC24	Report corrupted telegram, T2, and T3 as three separate Balises.	Report corrupted telegram, T2, and T3 as three separate Balises.
TC25	Report corrupted telegram from the main lobe as one Balise.	Report corrupted telegram from the main lobe as one Balise.
TC26	Report T1, corrupted telegram, and T3 as three separate Balises.	Report T1, corrupted telegram, and T3 as three separate Balises.
TC27	Report T1, corrupted telegram, and T3 as three separate Balises.	Report T1, corrupted telegram, and T3 as three separate Balises.
TC28	Report T2 from the main lobe as one Balise.	Report T2 from the main lobe as one Balise.
TC29	Report T2 from the main lobe as one Balise and corrupted telegram as another Balise.	Report T2 from the main lobe as one Balise and corrupted telegram as another Balise.
TC30	Report T1, T2, and corrupted telegram as three separate Balises.	Report T1, T2, and corrupted telegram as three separate Balises.
TC31	Report corrupted telegram from the main lobe as one Balise.	Report corrupted telegram from the main lobe as one Balise.
TC32	Report three corrupted telegrams as three separate Balises.	Report three corrupted telegrams as three separate Balises.
TC33	Report three corrupted telegrams as three separate Balises.	Report three corrupted telegrams as three separate Balises.

Case	With amplitude data	Without amplitude data
TC101	Report T2 from the main lobe as one Balise.	Report T2 from the main lobe as one Balise.
TC102	Report T1 as one Balise and T2 from the main lobe as another Balise. ⁴	Report T1 as one Balise and T2 from the main lobe as another Balise. ⁴
TC103	Report T1, T2, and T3 as three separate Balises.	Report T1, T2, and T3 as three separate Balises.
TC104	Report T2 from the main lobe as one Balise.	Report T2 from the main lobe as one Balise.
TC105	Report T2 from the main lobe as one Balise and T3 as another Balise. ⁴	Report T2 from the main lobe as one Balise and T3 as another Balise. ⁴
TC106	Report T1, T2, and T3 as three separate Balises.	Report T1, T2, and T3 as three separate Balises.
TC107	Report T2 from the main lobe as one Balise.	Report T2 from the main lobe as one Balise.
TC108	Report T1, T2, and T3 as three separate Balises. ⁴	Report T1, T2, and T3 as three separate Balises. ⁴
TC109	Report T1, T2, and T3 as three separate Balises.	Report T1, T2, and T3 as three separate Balises.
TC110	Report T2 from the main lobe as one Balise.	Report T2 from the main lobe as one Balise.
TC111	Report T2 from the main lobe as one Balise.	Report T2 from the main lobe as one Balise.
TC112	Report T1, T2, and T3 as three separate Balises.	Report T1, T2, and T3 as three separate Balises.
TC113	Report T2 from the main lobe as one Balise.	Report T2 from the main lobe as one Balise.
TC114	Report corrupted telegram as one Balise and T2 from the main lobe as another Balise.	Report corrupted telegram as one Balise and T2 from the main lobe as another Balise.
TC115	Report corrupted telegram, T2, and T3 as three separate Balises.	Report corrupted telegram, T2, and T3 as three separate Balises.
TC116	Report corrupted telegram from the main lobe as one Balise.	Report corrupted telegram from the main lobe as one Balise.
TC117	Report T1, corrupted telegram, and T3 as three separate Balises.	Report T1, corrupted telegram, and T3 as three separate Balises.
TC118	Report T1, corrupted telegram, and T3 as three separate Balises.	Report T1, corrupted telegram, and T3 as three separate Balises.

⁴ Unless the STM through other mechanisms is able to better determine the situation.

Case	With amplitude data	Without amplitude data
TC119	Report T2 from the main lobe as one Balise.	Report T2 from the main lobe as one Balise.
TC120	Report T2 from the main lobe as one Balise and corrupted telegram as another Balise.	Report T2 from the main lobe as one Balise and corrupted telegram as another Balise.
TC121	Report T1, T2, and corrupted telegram as three separate Balises.	Report T1, T2, and corrupted telegram as three separate Balises.
TC122	Report corrupted telegram from the main lobe as one Balise.	Report corrupted telegram from the main lobe as one Balise.
TC123	Report three corrupted telegrams as three separate Balises.	Report three corrupted telegrams as three separate Balises.
TC124	Report three corrupted telegrams as three separate Balises.	Report three corrupted telegrams as three separate Balises.
TC201	Report T2 as one Balise.	Report corrupted telegram as one Balise.
TC202	Report corrupted telegram and T2 as two separate Balises.	Report corrupted telegram and T2 as two separate Balises.
TC203	Report corrupted telegram and T2 as two separate Balises.	Report corrupted telegram and T2 as two separate Balises.
TC204	Report corrupted telegram as one Balise.	Report T2 as one Balise.
TC205	Report T1 and corrupted telegram as two separate Balises.	Report T1 and corrupted telegram as two separate Balises.
TC206	Report T1 and corrupted telegram as two separate Balises.	Report T1 and corrupted telegram as two separate Balises.
TC207	Report corrupted telegram from the main lobe as one Balise.	Report corrupted telegram from the side lobe as one Balise.
TC208	Report two corrupted telegram as two separate Balises.	Report two corrupted telegram as two separate Balises.
TC209	Report two corrupted telegram as two separate Balises.	Report two corrupted telegram as two separate Balises.
TC301	Report T4 from the main lobe as one Balise.	Report T4 from the main lobe as one Balise.
TC302	Report T4 from the main lobe as one Balise.	Report T4 from the main lobe as one Balise.
TC303	Report T2 from the largest side lobe and T4 from the main lobe as two separate Balise.	Report T3 from the third side lobe and T4 from the main lobe as two separate Balise.
TC304	Report T4 from the main lobe as one Balise.	Report T4 from the main lobe as one Balise.
TC305	Report corrupted telegram from the largest side lobe and T4 from the main lobe as two separate Balise.	Report corrupted telegram from the third side lobe and T4 from the main lobe as two separate Balise.
TC306	Report corrupted telegram from the largest side lobe and T4 from the main lobe as two separate Balise.	Report corrupted telegram from the third side lobe and T4 from the main lobe as two separate Balise.

Case	With amplitude data	Without amplitude data
TC307	Report corrupted telegram from the main lobe as one Balise.	Report corrupted telegram from the main lobe as one Balise.
TC308	Report corrupted telegram from the largest side lobe and corrupted telegram from the main lobe as two separate Balise.	Report corrupted telegram from the third side lobe and corrupted telegram from the main lobe as two separate Balise.
TC309	Report corrupted telegram from the largest side lobe and corrupted telegram from the main lobe as two separate Balise.	Report corrupted telegram from the third side lobe and corrupted telegram from the main lobe as two separate Balise.
TC401	Report T2 from the main lobe as one Balise.	Report T1 from the side lobe as one Balise.
TC402	Report T1 and T2 as two separate Balises.	Report T1 and T2 as two separate Balises.
TC403	Report T1 and T2 as two separate Balises.	Report T1 and T2 as two separate Balises.
TC501	Report restrictive aspect message as a separate Balise, and T2 as another Balise.	Report restrictive aspect message as a separate Balise, and T2 as another Balise.
TC601	Report corrupted telegram from the main lobe as one Balise.	Report T3 from the side lobe as one Balise.
TC602	Report corrupted telegram and T3 as two separate Balises.	Report corrupted telegram and T3 as two separate Balises.
TC603	Report corrupted telegram and T3 as two separate Balises.	Report corrupted telegram and T3 as two separate Balises.
TC604	Report T2 from the main lobe as one Balise.	Report corrupted telegram from the side lobe as one Balise.
TC605	Report T2 and corrupted telegram as two separate Balises.	Report T2 and corrupted telegram as two separate Balises.
TC606	Report T2 and corrupted telegram as two separate Balises.	Report T2 and corrupted telegram as two separate Balises.
TC607	Report corrupted telegram from the main lobe as one Balise.	Report corrupted telegram from the side lobe as one Balise.
TC608	Report two corrupted telegrams as two separate Balises.	Report two corrupted telegrams as two separate Balises.
TC609	Report two corrupted telegrams as two separate Balises.	Report two corrupted telegrams as two separate Balises.
TC701	For all signal strength levels, report T2 from the main lobe as one Balise.	For all signal strength levels, report corrupted telegram from the side lobe as one Balise.
TC702	For all signal strength levels, report T2 from the main lobe and corrupted telegram from the side lobe as separate Balises.	For all signal strength levels, report T2 from the main lobe and corrupted telegram from the side lobe as separate Balises.

Table 9: Acceptance Criteria for Side Lobe Management

5.2.9 Telegram Decoding

5.2.9.1 General Description, Telegram Decoding

This section defines the test procedure for verifying that the STM has the capability to decode a telegram during worst case conditions in the amount of received bits (i.e., the shortest allowed sequence required for decoding the telegram).

UNISIG SUBSET-100 defines the required amount of error free bits.

5.2.9.2 Test Pattern, Telegram Decoding

The STM manufacturer shall define a suitable test sequence and test patterns such that correct behaviour with respect to the data defined in section 5.2.9.1 is ensured.

Link Test Data shall be transmitted on a regular basis according to UNISIG SUBSET-101 (i.e., link checks shall be performed in accordance with UNISIG SUBSET-101).

Please observe that for some systems, the required number of bits may be dependent on the speed determined by the Time and Odometer information. A relevant number of test points (with respect to velocity) shall in such cases be defined by the supplier of the STM.

5.2.9.3 Test Procedure, Telegram Decoding

1. Transmit a sequence where the BD and TD data is correct for all Balises and chosen such that the minimum required contact length for telegram decoding is simulated.
2. Observe the reaction of the STM via the STM FFFIS.

5.2.9.4 Acceptance Criteria, Telegram Decoding

The following shall be verified via the STM FFFIS:

- Step 2 The STM continues to operate without loss of performance.

5.3 Laboratory Tests, Alternative 2 Interface

5.3.1 Electrical Data

See section 5.2.1 on page 66.

5.3.2 Data Transmission

See section 5.2.2 on page 67.

5.3.3 Timing Requirements

5.3.3.1 General Description, Timing Requirements

This section defines the test procedure for verifying the ability to cope with extreme timing requirements. The test procedures include verification of the following properties:

- Ability to cope with extreme ASK bit data rates
- Ability to cope with extreme phase difference between various channels (if more than one is implemented)
- Ability to cope with extremes in the relation between the Data and CLK signals

5.3.3.2 Test Pattern, Timing Requirements

The STM manufacturer shall define a suitable test sequence and test patterns such that correct handling of the imperfections in the parameters defined in section 5.3.3.1 is ensured.

If not explicitly otherwise defined, Link Tests shall be transmitted on a regular basis according to UNISIG SUBSET-101 (i.e., link tests shall be performed in accordance with UNISIG SUBSET-101).

5.3.3.3 Test Procedure, Timing Requirements

1. Transmit the system specific test sequence with the ASK bit data rate in Interface 'K' set to the nominal value as defined by UNISIG SUBSET-101.
2. Observe the reaction of the STM via the STM FFFIS.
3. Set the ASK bit data rate in Interface 'K' to the lower extreme defined by UNISIG SUBSET-101, and transmit the system specific test sequence.
4. Observe the reaction of the STM via the STM FFFIS.
5. Set the ASK bit data rate in Interface 'K' to the upper extreme defined by UNISIG SUBSET-101, and transmit the system specific test sequence.
6. Observe the reaction of the STM via the STM FFFIS.
7. Set the ASK bit data rate in Interface 'K' such that it is 50 % outside the lower tolerance in data rate as defined by UNISIG SUBSET-101, and transmit the system specific test sequence.
8. Observe the reaction of the STM via the STM FFFIS (including the reaction time).
9. Set the ASK bit data rate in Interface 'K' such that it is 50 % outside the upper tolerance in data rate as defined by UNISIG SUBSET-101, and transmit the system specific test sequence.
10. Observe the reaction of the STM via the STM FFFIS (including the reaction time).
11. Set the CLK pulse length to upper extreme defined by UNISIG SUBSET-101, and transmit the system specific test sequence.
12. Observe the reaction of the STM via the STM FFFIS.
13. Set the CLK pulse length to lower extreme defined by UNISIG SUBSET-101, and transmit the system specific test sequence.
14. Observe the reaction of the STM via the STM FFFIS.

The above steps shall be performed simultaneously transmitting the defined data rates at all channels. Furthermore:

15. Simulate the maximum allowed positive phase difference between the involved channels as defined by UNISIG SUBSET-101.
16. Observe the reaction of the STM via the STM FFFIS.
17. Simulate the maximum allowed negative phase difference between the involved channels as defined by UNISIG SUBSET-101.
18. Observe the reaction of the STM via the STM FFFIS.

5.3.3.4 Acceptance Criteria, Timing Requirements

For each of the steps 2, 4, 6, 12, 14, 16, and 18, it shall be verified that the STM continues to operate without loss of performance.

For each of the steps 8 and 10, verify that the manufacturer dependent reaction is obtained within the stipulated reaction time.

5.3.4 Functional Data

5.3.4.1 General Description, Functional Data

This section defines the test procedure for verifying the correct reaction on data from a functional perspective. The test procedure includes verification of the following properties:

- Handling of Data
- Handling of Eurobalise (FSK) indication
- Handling of link tests

The requirements related to diversified data defined in UNISIG SUBSET-101 will also be verified from a receiver perspective. Finally, simulation of the Interface 'K' link set to inactive, indicating permanently failing BTM functionality, is also simulated in order to verify that the STM correctly copes with such a situation.

5.3.4.2 Test Pattern, Functional Data

The STM manufacturer shall define a suitable test sequence and test patterns such that the correct behaviour with respect to the data defined in section 5.3.4.1 is ensured.

If not explicitly otherwise defined, Link Tests shall be transmitted on a regular basis according to UNISIG SUBSET-101 (i.e., link tests shall be performed in accordance with UNISIG SUBSET-101).

If otherwise not explicitly mentioned in the test procedure, it is assumed that a correctly operative sequence without imperfections is transmitted. Deviations from this condition (e.g., introduction of failure conditions) are explicitly defined.

5.3.4.3 Test Procedure, Functional Data

1. Transmit the correct sequence.
2. Observe the reaction of the STM via the STM FFFIS.
3. For at least one of the Balise passages, introduce incorrect Data.
4. Observe the reaction of the STM via the STM FFFIS.
5. Introduce at least one additional Balise marked as Eurobalise (using the definitions of UNISIG SUBSET-101).
6. Observe the reaction of the STM via the STM FFFIS.
7. Occasionally discontinue the transmission of repetitive link checks such that UNISIG SUBSET-101 is violated in this respect.
8. Observe the reaction of the STM via the STM FFFIS.
9. Occasionally transmit link checks that are longer than the requirements of UNISIG SUBSET-101.
10. Observe the reaction of the STM via the STM FFFIS.
11. Introduce transmission of a long correct Balise passage (e.g., 2 s), and ensure that a correct link test is introduced 1 s after the start of the Balise (thus temporarily interrupting transmission of Balise data).
12. Observe the reaction of the STM via the STM FFFIS.
13. Simulate that Tele-powering is erroneously switched off (indicated through keeping the CLK signal at constant polarity) for a period of more than 500 ms.
14. Observe the reaction of the STM via the STM FFFIS.
15. Set the Interface 'K' channel to absence of activity and observe the reaction of the STM via the STM FFFIS.

The above steps shall be performed simultaneously transmitting the same data at all involved channels (except for step 15, where one single link shall be tested at a time). Furthermore:

16. Transmit the correct sequence in one channel, and introduce incorrect Data in the other channel.
17. Observe the reaction of the STM via the STM FFFIS.
18. Transmit the correct sequence in one channel, and introduce in at least one Balise passage that the Balise is marked as Eurobalise in the other channel.
19. Observe the reaction of the STM via the STM FFFIS.
20. Transmit the correct sequence in one channel, and introduce discontinued transmission of repetitive link checks in the other channel.
21. Observe the reaction of the STM via the STM FFFIS.
22. Transmit the correct sequence in one channel, and introduce transmission of too long link tests in the other channel.
23. Observe the reaction of the STM via the STM FFFIS.
24. Transmit the correct sequence in one channel, and introduce for a period of time exceeding 500 ms that Tele-powering is erroneously switched off in the other channel (indicated through keeping the CLK signal at constant polarity).
25. Observe the reaction of the STM via the STM FFFIS.

The steps from step 16 until the end shall be repeated such that the abnormalities in the sequences are applied to one channel at a time (while the others have normal conditions).

5.3.4.4 Acceptance Criteria, Functional Data

The following shall be verified via the STM FFFIS:

- Step 2 The STM continues to operate without loss of performance.
- Step 4 The STM detects all Balises, and detects the situation with loss of telegram. Verify that the manufacturer dependent reaction is obtained within the stipulated reaction time.
- Step 6 The STM continues to operate without loss of performance.
- Step 8 The STM detects that link checks are missing. Verify that the manufacturer dependent reaction is obtained within the stipulated reaction time.
- Step 10 The STM detects that link checks are too long. Verify that the manufacturer dependent reaction is obtained within the stipulated reaction time.
- Step 12 The STM continues to operate without loss of performance.
- Step 14 The STM detects that ERMS is unavailable. Verify that the manufacturer dependent reaction is obtained within the stipulated reaction time.
- Step 15 The STM detects that Interface 'K' is not active. Verify that the manufacturer dependent reaction is obtained within the stipulated reaction time.
- Step 17 The STM detects all Balises, and detects the situation with loss of telegram. Verify that the manufacturer dependent reaction is obtained within the stipulated reaction time.
- Step 19 The STM continues to operate without loss of performance.
- Step 21 The STM detects that link checks are missing. Verify that the manufacturer dependent reaction is obtained within the stipulated reaction time.
- Step 23 The STM detects that link checks are too long. Verify that the manufacturer dependent reaction is obtained within the stipulated reaction time.
- Step 25 The STM detects that ERTMS is not available. Verify that the manufacturer dependent reaction is obtained within the stipulated reaction time.

5.3.5 Link Check Functionality

5.3.5.1 General Description, Link Check Functionality

This section defines the test procedure for verifying the correct reaction on signalling used for on-line supervision of the Interface 'K' link. The test procedure includes verification of the following properties:

- Correct reaction on link check pattern

5.3.5.2 Test Pattern, Link Check Functionality

The STM manufacturer shall define a suitable test sequence and test patterns such that correct behaviour with respect to the data defined in section 5.3.5.1 is ensured.

No Balise passages shall be simulated (unless the possible initial sequence required for setting the system in a define state/mode), and the time between successive link checks shall be set to 400 ms.

5.3.5.3 Test Procedure, Link Check Functionality

1. Transmit the correct link check pattern.
2. Observe the reaction of the STM via the STM FFFIS.
3. Transmit a link check pattern but with too long duration.
4. Observe the reaction of the STM via the STM FFFIS.
5. Transmit a link check pattern according to SUBSET-101, but with Data held at logical low level after the CLC signal is held at permanently low logical level.
6. Observe the reaction of the STM via the STM FFFIS.
7. Transmit a link check pattern according to SUBSET-101, but with Data held at permanently high logical level throughout the sequence.
8. Observe the reaction of the STM via the STM FFFIS.

5.3.5.4 Acceptance Criteria, Link Check Functionality

The following shall be verified via the STM FFFIS:

- | | |
|-------------------|--|
| Step 2 | The STM continues to operate without loss of performance. |
| Steps 4, 6, and 8 | The STM detects that link checks are corrupt. Verify that the manufacturer dependent reaction is obtained within the stipulated reaction time. |

In case of several channels, the STM shall detect if a failure condition is occurring in any single channel.

5.3.6 Handling of Diversified Data

Fulfilment of the basic requirements for ensuring correct handling of diversified data is verified through the tests included in section 5.3.4 on page 93.

5.3.7 Detection of Balises

5.3.7.1 General Description, Detection of Balises

See section 5.2.7.1 on page 76.

5.3.7.2 Test Pattern, Detection of Balises

See section 5.2.7.2 on page 76.

5.3.7.3 Test Procedure, Detection of Balises

1. Transmit a sequence where the Data is correct for all Balises and chosen such that the minimum required contact length for Balise Detect is simulated.
2. Observe the reaction of the STM via the STM FFFIS.

5.3.7.4 Acceptance Criteria, Detection of Balises

The following shall be verified via the STM FFFIS:

- Step 2 The STM either continues to operate without loss of performance.

5.3.8 Management of Side Lobe Effects

5.3.8.1 General Description, Management of Side Lobe Effects

This section defines the test procedure for verifying the correct reaction in the presence of various side lobe conditions. The test procedure includes verification of the following properties:

- Handling of side lobes positioned at various distances from the main lobe
- Handling of telegram shift in combination with side lobes
- Handling of side lobes when no telegram decoding is possible
- Handling of multiple side lobes
- Behaviour when restrictive aspect messages are transmitted

In general, all test cases should be designed such that the specific properties detailed herein are put in a wider context in order to constitute meaningful system specific information that can be handled by the STM (and a relevant reaction can be observed). It is the responsibility of the STM manufacturer to define the needed details. It should be observed that the specifics in the patterns aiming at verifying the side lobe handling properties shall be such that it is possible to positively identify the reaction (e.g., unique telegrams shall be used in various lobes unless explicitly stated to be identical, and these shall be selected such that different system reactions are obtained if the reaction is observed on system level).

Telegram contents indicated herein (T1, T2, etc.) are system specific, and need to be defined by the STM manufacturer. The indications on indicated telegram contents are not global (i.e., T1 in one test case may be different from T1 in another test case).

If it is found suitable, a specific test interface may be implemented on the STM. Via such a test interface, detailed reporting on selection of lobes and telegram contents may be provided (rather than observing system oriented reactions via the STM FFFIS). If a specific test interface is adopted, the manufacturer shall through specific verifications prove that the test interface response is correlated with the operational STM algorithms

5.3.8.2 Test Pattern, Management of Side Lobe Effects

5.3.8.2.1 General

The STM manufacturer shall define suitable test sequences and test patterns such that the correct behaviour with respect to the mechanisms defined in section 5.3.8.1 is ensured.

Link tests shall be transmitted on a regular basis according to UNISIG SUBSET-101 (i.e., link tests shall be performed in accordance with UNISIG SUBSET-101).

It is in general assumed that a correctly operative sequence without imperfections is transmitted unless otherwise explicitly defined.

5.3.8.2.2 Definitions

In general, lobes with the following general characteristics shall be generated. The shown lobes represent transmission of data. Data is transmitted according to telegram information during the entire lobes (L1, L2, and L3).

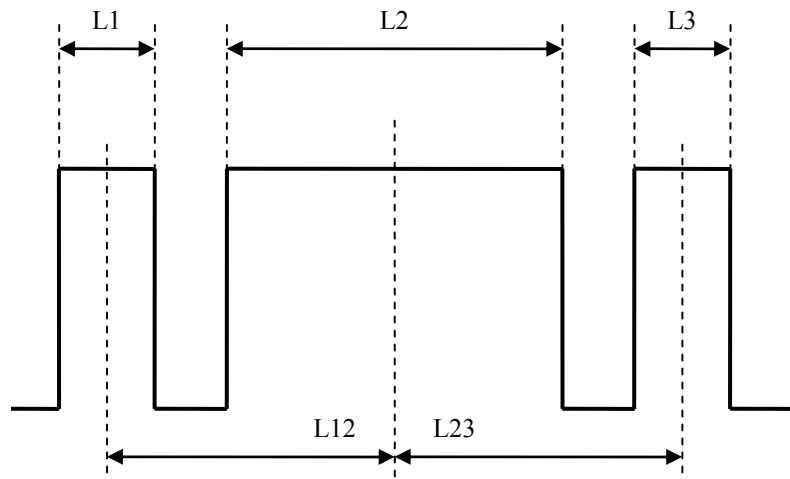

Figure 18: General shape of lobes, Alternative 2

The following applies to the parameters in Figure 18 for the test cases defined in section 5.3.8.2.3 on page 102. The aim is to systematically verify that STM concludes in accordance with the requirement matrix included in UNISIG SUBSET-101 considering that no amplitude information is available.

- The width of the first and the third lobes (L1 and L3 respectively) shall be equal and correspond to 0.25 m.
- The width of the second lobe (L2) shall correspond to 0.4 m.
- The distance between the mid points of the lobes, L12 and L23 respectively, shall be equal and in accordance with the various test cases defined in section 5.3.8.2.3 on page 102.
- During the simulation of the lobes according to Figure 18, the speed 100 km/h shall be used.
- The telegram contents transmitted during the lobes are hereafter referred to as T1, T2, and T3 respectively for the three lobes. In the general test cases (section 5.3.8.2.3 on page 102) it is assumed that when identical telegrams are chosen, they do not constitute data consistent with possible Balise group configuration (this is separately dealt with in a specific test case in section 5.3.8.2.4 on page 103).

For the purpose of verifying handling of only one side lobe before the main lobe (test cases 201 through 209 in section 5.3.8.2.4 on page 103), the following applies. The aim is to verify that the STM correctly makes the correct decision on main lobe.

- The third lobe shall not be generated ($L3 = 0$)
- The width of the first lobe ($L1$) shall correspond to 0.25 m.
- The width of the second lobe ($L2$) shall correspond to 0.4 m.
- The distance between the mid points of the lobes, $L12$, shall be in accordance with the various test cases defined in section 5.3.8.2.4 on page 103 (test cases 201 through 209).
- During the simulation of the lobes according to Figure 18, the speed 100 km/h shall be used.
- The telegram contents transmitted during the lobes are hereafter referred to as T1 and T2 respectively for the two lobes.

The above also applies to testing the behaviour when the first lobe includes transmission of a restrictive aspect message (test case 501 in section 5.3.8.2.3 on page 102).

For the purpose of verifying handling of only one side lobe after the main lobe (test cases 601 through 609 in section 5.3.8.2.4 on page 103), the following applies. The aim is to verify that the STM correctly makes the correct decision on main lobe.

- The first lobe shall not be generated ($L1 = 0$)
- The width of the third lobe ($L3$) shall correspond to 0.25 m.
- The width of the second lobe ($L2$) shall correspond to 0.4 m.
- The distance between the mid points of the lobes, $L23$, shall be in accordance with the various test cases defined in section 5.3.8.2.4 on page 103 (test cases 601 through 609).
- During the simulation of the lobes according to Figure 18, the speed 100 km/h shall be used.
- The telegram contents transmitted during the lobes are hereafter referred to as T2 and T3 respectively for the two lobes.

For the specific case that identical telegrams are chosen such that they constitute data consistent with possible Balise group configuration (test cases 401 through 403 in section 5.3.8.2.4 on page 103), the following applies:

- The third lobe shall not be generated ($L3 = 0$)
- The width of the first lobe ($L1$) shall correspond to 0.25 m.
- The width of the second lobe ($L2$) shall correspond to 0.4 m.
- The distance between the mid points of the lobes, $L12$, shall be in accordance with the various test cases defined in section 5.3.8.2.4 on page 103 (test cases 401 through 403).
- During the simulation of the lobes according to Figure 18, the speed 100 km/h shall be used.
- The telegram contents transmitted during the lobes are hereafter referred to as T1 and T2 respectively for the two lobes. It is assumed that identical telegrams are chosen such that they constitute data consistent with possible Balise group.

For the purpose of verifying handling of multiple side lobes, the following characteristics shall be generated. The shown lobes represent data transmission. Data is transmitted according to telegram information during the entire lobes (L1, L2, L3, and L4).

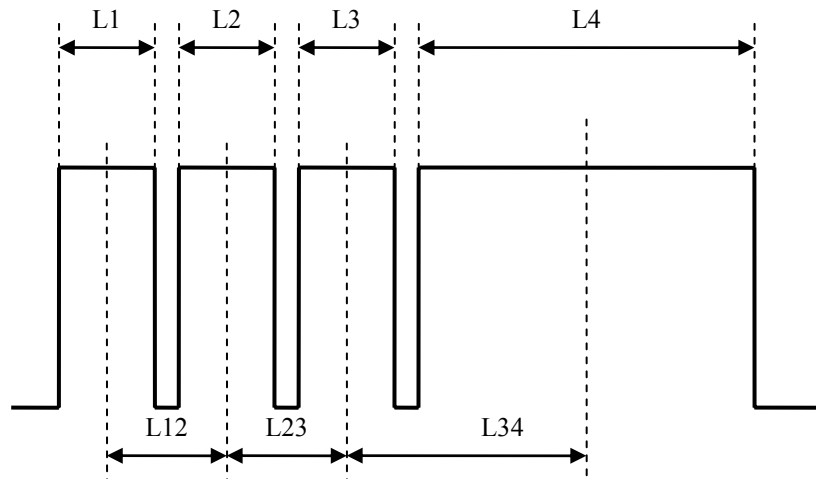

Figure 19: Shape of multiple side lobes, Alternative 2

For the purpose of verifying handling of multiple side lobes (test cases 301 through 309 in 5.3.8.2.4 on page 103), the following applies:

- The width of the first lobe (L1) shall correspond to 0.15 m.
- The width of the second lobe (L2) shall correspond to 0.20 m.
- The width of the third lobe (L3) shall correspond to 0.25 m.
- The width of the fourth lobe (L4) shall correspond to 0.4 m.
- The distance between the mid points of the first three lobes, L12 and L23 respectively, shall be 0.25 m and the distance between the third and the fourth lobe, L34, shall be in accordance with the various test cases defined in section 5.3.8.2.4 on page 103 (test cases 301 through 309).
- During the simulation of the lobes according to Figure 19, the speed 50 km/h shall be used.
- The telegram contents transmitted during the lobes are hereafter referred to as T1, T2, T3, and T4 respectively for the four lobes. It is assumed that when identical telegrams are chosen, they do not constitute data consistent with possible Balise group configuration.

5.3.8.2.3 General Test Cases

For systems having a coding strategy such that it includes dedicated variables that can be used for determining if different telegrams belong to the same Balise or to two different Balises (e.g., Ebicab 900), the following apply. See also Figure 18 of section 5.3.8.2.2 on page 99 and the corresponding definitions.

L12 T	0.5 m	1.0 m	2.0 m
Different telegrams indicate different Balises. T1 ≠ T2, T2 = T3	TC1	TC2	TC3
Different telegrams indicate different Balises. T1 = T2, T2 ≠ T3	TC4	TC5	TC6
Different telegrams indicate different Balises. T1 ≠ T2, T2 ≠ T3, T1 ≠ T3	TC7	TC8	TC9
T1 = T2 = T3	TC10	TC11	TC12
Different telegrams indicate same Balise. T1 ≠ T2, T2 = T3	TC13	TC14	TC15
Different telegrams indicate same Balise. T1 = T2, T2 ≠ T3	TC16	TC17	TC18
Different telegrams indicate same Balise. T1 ≠ T2, T2 ≠ T3, T1 ≠ T3	TC19	TC20	TC21
Corrupted telegram in the first lobe, T2 = T3	TC22	TC23	TC24
Corrupted telegram in the second lobe, T1 = T3	TC25	TC26	TC27
Corrupted telegram in the third lobe, T1 = T2	TC28	TC29	TC30
Corrupted telegram in all lobes.	TC31	TC32	TC33

Table 10: Test Cases when telegram content confirms Balise identity

For systems having a coding strategy and situations such that it is not possible to determine if different telegrams belong to the same Balise or to two different Balises, the following apply. See also Figure 18 of section 5.3.8.2.2 on page 99 and the corresponding definitions.

L12 T	0.5 m	1.0 m	2.0 m
T1 ≠ T2, T2 = T3	TC101	TC102	TC103
T1 = T2, T2 ≠ T3	TC104	TC105	TC106
T1 ≠ T2, T2 ≠ T3, T1 ≠ T3	TC107	TC108	TC109
T1 = T2 = T3	TC110	TC111	TC112
Corrupted telegram in the first lobe, T2 = T3	TC113	TC114	TC115
Corrupted telegram in the second lobe, T1 = T3	TC116	TC117	TC118
Corrupted telegram in the third lobe, T1 = T2	TC119	TC120	TC121
Corrupted telegram in all lobes.	TC122	TC123	TC124

Table 11: Test Cases when telegram content does not confirm Balise identity

5.3.8.2.4 Specific Test Cases

For the purpose of testing handling when only one side lobe is preceding the main lobe, the following test cases shall be applied. See also Figure 18 of section 5.3.8.2.2 on page 99 and the corresponding definitions.

L12 T	0.5 m	1.0 m	2.0 m
Corrupted telegram in the first lobe	TC201	TC202	TC203
Corrupted telegram in the second lobe	TC204	TC205	TC206
Corrupted telegram in all lobes.	TC207	TC208	TC209

Table 12: Test Cases for testing handing preceding side lobes

For the purpose of testing that multiple side lobes are correctly handled, the following test cases shall be applied. See also Figure 19 of section 5.3.8.2.2 on page 99 and the corresponding definitions.

L34 T	0.5 m	1.0 m	2.0 m
T1 = T2 = T3 =T4	TC301	TC302	TC303
Corrupted telegram in the first three lobes	TC304	TC305	TC306
Corrupted telegram in all lobes.	TC307	TC308	TC309

Table 13: Test Cases for testing handing of multiple side lobes

It is assumed that identical telegrams are chosen such that they do not constitute data consistent with possible Balise group configuration.

For the purpose of testing the behaviour when identical telegrams are consistent with a possible Balise group configuration, the following test cases shall be applied. See also Figure 18 of section 5.3.8.2.2 on page 99 and the corresponding definitions.

L12 T	0.5 m	1.0 m	2.0 m
T1 = T2	TC401	TC402	TC403

Table 14: Test Cases for testing handing consistent Balise group data

It is assumed that the telegrams are chosen such that they constitute data consistent with possible Balise group configuration.

For the purpose of testing the behaviour when a restrictive aspect message is transmitted in the first lobe, the following test case shall be applied. See also Figure 18 of section 5.3.8.2.2 on page 99 and the corresponding definitions.

L12	0.5 m	1.0 m	2.0 m
T			
T1 = Restrictive aspect message, T2 = normal message	TC501	-	-

Table 15: Test Cases for testing handing restrictive aspect message

Please observe that this test case must be designed such that the STM recognises that the information is relevant for the selected travelling direction.

For the purpose of testing handling when only one side lobe is succeeding the main lobe, the following test cases shall be applied. See also Figure 18 of section 5.3.8.2.2 on page 99 and the corresponding definitions.

L23	0.5 m	1.0 m	2.0 m
T			
Corrupted telegram in the second lobe	TC601	TC602	TC603
Corrupted telegram in the third lobe	TC604	TC605	TC606
Corrupted telegram in all lobes.	TC607	TC608	TC609

Table 16: Test Cases for testing handing succeeding side lobes

5.3.8.3 Test Procedure, Management of Side Lobe Effects

The test patterns defined in section 5.3.8.2 on page 98 shall be generated and transmitted to the STM via Interface 'K'.

Test cases according to either Figure 18 or Figure 19, or both, shall be performed (dependent on the applicable coding strategy and relevant situations).

The resulting reaction of the STM shall be observed via the STM FFFIS, or via an explicit test interface (if available), and be verified to comply with the acceptance criteria defined in section 5.3.8.4 on page 105.

Link tests shall be transmitted on a regular basis outside the Balise contact volume according to UNISIG SUBSET-101.

5.3.8.4 Acceptance Criteria, Management of Side Lobe Effects

The following acceptance criteria apply to the test cases defined in section 5.3.8.2 on page 98.

When it is stated “report” in the table below, the meaning is that the information is either explicitly provided via a suitable test interface, or that the defined evaluation is indicated as part of an overall context (system level oriented reaction).

Case	Expected Result
TC1	Report T1 as one Balise and T2 from the main lobe as another Balise.
TC2	Report T1 as one Balise and T2 from the main lobe as another Balise.
TC3	Report T1, T2, and T3 as three separate Balises.
TC4	Report T2 from the main lobe as one Balise and T3 as another Balise.
TC5	Report T2 from the main lobe as one Balise and T3 as another Balise.
TC6	Report T1, T2, and T3 as three separate Balises.
TC7	Report T1, T2, and T3 as three separate Balises.
TC8	Report T1, T2, and T3 as three separate Balises.
TC9	Report T1, T2, and T3 as three separate Balises.
TC10	Report T2 from the main lobe as one Balise.
TC11	Report T2 from the main lobe as one Balise.
TC12	Report T1, T2, and T3 as three separate Balises.
TC13	Report T2 from the main lobe as one Balise.
TC14	Report T2 from the main lobe as one Balise.
TC15	Report T2 from the main lobe as one Balise and T3 as another Balise.
TC16	Report T2 from the main lobe as one Balise.
TC17	Report T2 from the main lobe as one Balise.
TC18	Report T1 as one Balise and T2 from the main lobe as another Balise.
TC19	Report T2 from the main lobe as one Balise.
TC20	Report T2 from the main lobe as one Balise.
TC21	Report T2 from the main lobe as one Balise.
TC22	Report T2 from the main lobe as one Balise.
TC23	Report corrupted telegram as one Balise and T2 from the main lobe as another Balise.
TC24	Report corrupted telegram, T2, and T3 as three separate Balises.
TC25	Report corrupted telegram from the main lobe as one Balise.
TC26	Report T1, corrupted telegram, and T3 as three separate Balises.
TC27	Report T1, corrupted telegram, and T3 as three separate Balises.
TC28	Report T2 from the main lobe as one Balise.
TC29	Report T2 from the main lobe as one Balise and corrupted telegram as another Balise.
TC30	Report T1, T2, and corrupted telegram as three separate Balises.
TC31	Report corrupted telegram from the main lobe as one Balise.
TC32	Report three corrupted telegrams as three separate Balises.
TC33	Report three corrupted telegrams as three separate Balises.

Case	Expected Result
TC101	Report T2 from the main lobe as one Balise.
TC102	Report T1 as one Balise and T2 from the main lobe as another Balise. ⁵
TC103	Report T1, T2, and T3 as three separate Balises.
TC104	Report T2 from the main lobe as one Balise.
TC105	Report T2 from the main lobe as one Balise and T3 as another Balise. ⁵
TC106	Report T1, T2, and T3 as three separate Balises.
TC107	Report T2 from the main lobe as one Balise.
TC108	Report T1, T2, and T3 as three separate Balises. ⁵
TC109	Report T1, T2, and T3 as three separate Balises.
TC110	Report T2 from the main lobe as one Balise.
TC111	Report T2 from the main lobe as one Balise.
TC112	Report T1, T2, and T3 as three separate Balises.
TC113	Report T2 from the main lobe as one Balise.
TC114	Report corrupted telegram as one Balise and T2 from the main lobe as another Balise.
TC115	Report corrupted telegram, T2, and T3 as three separate Balises.
TC116	Report corrupted telegram from the main lobe as one Balise.
TC117	Report T1, corrupted telegram, and T3 as three separate Balises.
TC118	Report T1, corrupted telegram, and T3 as three separate Balises.
TC119	Report T2 from the main lobe as one Balise.
TC120	Report T2 from the main lobe as one Balise and corrupted telegram as another Balise.
TC121	Report T1, T2, and corrupted telegram as three separate Balises.
TC122	Report corrupted telegram from the main lobe as one Balise.
TC123	Report three corrupted telegrams as three separate Balises.
TC124	Report three corrupted telegrams as three separate Balises.
TC201	Report T2 as one Balise.
TC202	Report corrupted telegram and T2 as two separate Balises.
TC203	Report corrupted telegram and T2 as two separate Balises.
TC204	Report corrupted telegram as one Balise.
TC205	Report T1 and corrupted telegram as two separate Balises.
TC206	Report T1 and corrupted telegram as two separate Balises.
TC207	Report corrupted telegram from the main lobe as one Balise.
TC208	Report two corrupted telegram as two separate Balises.
TC209	Report two corrupted telegram as two separate Balises.

⁵ Unless the STM through other mechanisms is able to better determine the situation.

Case	Expected Result
TC301	Report T4 from the main lobe as one Balise.
TC302	Report T4 from the main lobe as one Balise.
TC303	Report T3 from the third side lobe and T4 from the main lobe as two separate Balise.
TC304	Report T4 from the main lobe as one Balise.
TC305	Report corrupted telegram from the third side lobe and T4 from the main lobe as two separate Balise.
TC306	Report corrupted telegram from the third side lobe and T4 from the main lobe as two separate Balise.
TC307	Report corrupted telegram from the main lobe as one Balise.
TC308	Report corrupted telegram from the third side lobe and corrupted telegram from the main lobe as two separate Balise.
TC309	Report corrupted telegram from the third side lobe and corrupted telegram from the main lobe as two separate Balise.
TC401	Report T2 as one Balise.
TC402	Report T1 and T2 as two separate Balises.
TC403	Report T1 and T2 as two separate Balises.
TC501	Report restrictive aspect message as a separate Balise, and T2 as another Balise.
TC601	Report corrupted telegram as one Balise.
TC602	Report corrupted telegram and T3 as two separate Balises.
TC603	Report corrupted telegram and T3 as two separate Balises.
TC604	Report T2 as one Balise.
TC605	Report T2 and corrupted telegram as two separate Balises.
TC606	Report T2 and corrupted telegram as two separate Balises.
TC607	Report corrupted telegram from the main lobe as one Balise.
TC608	Report two corrupted telegrams as two separate Balises.
TC609	Report two corrupted telegrams as two separate Balises.

Table 17: Acceptance Criteria for Side Lobe Management

5.3.9 Telegram Decoding

5.3.9.1 General Description, Telegram Decoding

See section 5.2.9.1 on page 90.

5.3.9.2 Test Pattern, Telegram Decoding

See section 5.2.9.2 on page 90.

5.3.9.3 Test Procedure, Telegram Decoding

1. Transmit a sequence where the Data is correct for all Balises and chosen such that the minimum required contact length for telegram decoding is simulated.
2. Observe the reaction of the STM via the STM FFFIS.

5.3.9.4 Acceptance Criteria, Telegram Decoding

The following shall be verified via the STM FFFIS:

- Step 2 The STM continues to operate without loss of performance.

5.4 Requirements for Test Tools

See UNISIG SUBSET-085, and applicable annexes herein.

Annex A, Measurement Points

A1 Test Points for Contact Zone and Side-lobe Zone

In general, the geometrical test points shall be chosen such that various Antenna Units can be verified with respect to the required contact length and considering potential side lobes at different lateral deviations.

The Antenna Units shall be verified for minimum, nominal, and maximum heights. The nominal height is defined as the sum of the mean value of the static position for the Antenna Unit in question, and the highest specified position of the Balise. This section defines the full set of geometrical test points. Tailoring will be made during certain tests (see test matrices according to chapters A3 and A4 on pages 111 and 112 respectively).

During testing, the X-positions should be selected according to:

From 0 mm to ± 500 mm, in steps of 20 mm (total of 51 points).

From ± 550 mm to ± 1300 mm, in steps of 50 mm (total of 32 points).

The first zone (from 0 to ± 500 mm) is referred to as contact zone in the test matrices of chapters A3 and A4 on pages 111 and 112 respectively, and the second zone (from ± 500 mm to ± 1300 mm) is referred to as side lobe zone.

The lateral positions (Y-positions) shall be defined by the Antenna Unit supplier (for each lateral deviation, testing shall be performed at the X-positions defined above).

The geometrical test position [$X = 0$, $Y = 0$, $Z = \text{maximum height}$] is denominated the geometrical reference point (see sections 4.2.6.2.1 and 4.2.6.3.1 on page 36 and 40 respectively).

It is the responsibility of the supplier of the Antenna Unit to define the profile of maximum lateral deviation versus vehicle speed. This profile shall take into consideration the requirements on Balise installation (specified in UNISIG SUBSET-100), and the installation dependent requirements for each Antenna Unit type in question (defined by the supplier of the Antenna).

A2 Test Points for Cross-talk Protected Zone

The following geometrical positions shall be tested:

Point	x [mm]	y [mm]	Point	x [mm]	y [mm]
CT1	0	+1400	CT2	0	-1400
CT3	0	+1600	CT4	0	-1600
CT5	0	+1800	CT6	0	-1800
CT7	0	+2000	CT8	0	-2000
CT9	0	+2200	CT10	0	-2200
CT11	0	+2400	CT12	0	-2400
CT13	0	+2600	CT14	0	-2600
CT15	0	+2800	CT16	0	-2800
CT17	0	+3000	CT18	0	-3000
CT19	0	+3200	CT20	0	-3200
CT21	0	+3400	CT22	0	-3400
CT23	0	+3600	CT24	0	-3600
CT25	+1400	0	CT26	-1400	0
CT27	+1600	0	CT28	-1600	0
CT29	+1800	0	CT30	-1800	0
CT31	+2000	0	CT32	-2000	0
CT33	+2200	0	CT34	-2200	0
CT35	+2400	0	CT36	-2400	0
CT37	+2600	0	CT38	-2600	0
CT39	+2800	0	CT40	-2800	0
CT41	+3000	0	CT42	-3000	0
CT43	+3200	0	CT44	-3200	0
CT45	+3400	0	CT46	-3400	0
CT47	+3600	0	CT48	-3600	0

Table 18: Geometrical test points for On-board Cross-talk verification

The Antenna Unit shall be positioned at the minimum and the maximum heights as defined by the supplier.

A3 Test Matrix for Transmission and Cross-talk tests

A3.1 Test Conditions versus Test Zones

The following applies to tests defined by the sections 4.2.6.2 on page 36, 4.2.6.4 on page 46, and 4.2.6.8 on page 52. The test zones referred to in the table are defined in the chapters A1 on page 109 and A2 on page 110.

The following combinations of test conditions and test zones shall be tested:

Test Condition	Section	Contact Zone	Side Lobe Zone	Cross-talk Zone
Nominal	4.1.4.1	X	X	X
Tilt	4.1.4.2.1	X		X
Pitch	4.1.4.2.1	X	X	
Salt Water	4.1.4.2.2	X		
Clear Water	4.1.4.2.2	X		
Iron Ore	4.1.4.2.2	X		

Table 19: Transmission and Cross-talk Tests, Test Conditions versus Test Zones

Performance over temperature range is considered through spot check evaluation according to section 4.2.6.2.2 on page 38 (and section 4.2.6.3 on page 40).

A3.2 Test Conditions versus Geometrical Test Points

The following applies to tests defined by the sections 4.2.6.2 on page 36, 4.2.6.4 on page 46, and 4.2.6.8 on page 52. The test zones referred to in the table are defined in the chapters A1 on page 109 and A2 on page 110.

During the testing, the number of test points within the contact and side lobe zone shall be according to Table 20 below. The reason is that the number of test points defined in section A1 on page 109 needs to be minimised.

Test Condition	Section	Full	R1	R2
Nominal	4.1.4.1	X		
Tilt	4.1.4.2.1		X	
Pitch	4.1.4.2.1		X	
Salt Water	4.1.4.2.2			X
Clear Water	4.1.4.2.2			X
Iron Ore	4.1.4.2.2			X

Table 20: Transmission and Cross-talk Tests, Geometrical Test Points within the Contact Zone

The following is applicable:

- ‘Full’ indicates all points according to section A1 on page 109.
- ‘R1’ indicates maximum and minimum height only. In addition to this, a further limitation is that minimum height only applies within the side lobe zone.
- ‘R2’ indicates maximum height only.

A4 Test Matrix for Other Characteristics

A4.1 Test Conditions versus Characteristics

The following applies to tests defined by the sections 4.2.6.7 on page 51, 4.2.6.5 on page 49, and 4.2.6.6 on page 49. The applicable geometrical test points are further defined by chapter A1 on page 109.

The following combinations of characteristics and test conditions shall be tested:

Test Condition	Section	Up-link Electrical Char. (Section 4.2.6.7)	Tele-powering Char. (Section 4.2.6.5)	Maximum Flux Level (Section 4.2.6.6)
Nominal ⁶	4.1.4.1	X	X	X
Tilt	4.1.4.2.1			
Pitch	4.1.4.2.1			
Salt Water	4.1.4.2.2			
Clear Water	4.1.4.2.2			
Iron Ore	4.1.4.2.2			

Table 21: Other Characteristics, Characteristics versus Test Conditions

Tele-powering Characteristics are evaluated at nominal temperature, and at upper and lower temperature extremes.

A4.2 Test Conditions versus Geometrical Test Points

The following applies to tests defined by the sections 4.2.6.7 on page 51, 4.2.6.5 on page 49, and 4.2.6.6 on page 49. The applicable geometrical test points are further defined by chapter A1 on page 109.

During the testing, the number of test points within the Contact and Side Lobe Zone shall be according to Table 22 below. Testing within the cross-talk zone is not applicable for these tests. The reason is that the number of test points defined in chapter A1 on page 109 need to be minimised.

Test Case	Section	R3	R4	R5
Up-link Electrical Characteristics	4.2.6.7	X		X
Tele-powering Characteristics	4.2.6.5		X	
Maximum Flux Level	4.2.6.6			X

Table 22: Other Characteristics, Geometrical Test Points

The following is applicable:

- ‘R3’ indicates nominal height with no lateral displacement only.
- ‘R4’ indicates nominal height at position [X=0, Y=0] only.
- ‘R5’ indicates minimum height with no lateral displacement and within the Contact Zone only.

⁶ Applicable parts of nominal conditions apply (e.g., during tests of Up-link Electrical Characteristics the conditions for the Up-link signal are modified in accordance with the test procedure). Please refer to the specific test procedures for more details.

Annex B, Test Tools and Instruments

B1 Recommended Test Tools and Instruments

The following list includes suitable test equipment. Other equipment with similar performance may substitute these. "Item" refers to numbers in the Test and Calibration configurations.

<u>Item:</u>	<u>Equipment:</u>	<u>Type:</u>	<u>Comment:</u>
2	Attenuator	6 dB	
3	RF Power Amplifier	ENI A150	100 W
4	Attenuator	3 dB	100 W
7	Reference Loop	various, see SUBSET-085	
10	Power Meter Power Sensors	R&S NRVD R&S NRV-Z5	
12	Low Pass Filter	Mini Circuits, BLP-10.7	
13	Signal Generator	AWG 520	
14	Current Sense Balun	See SUBSET-085	Has to be calibrated
20	General purpose Balun	See SUBSET-085	
29	Attenuator	3 dB	30 W
31	Attenuator	20 dB	20 W, VSWR < 1:1.05
32	Current probe	Tektronix CT-2	Has to be calibrated
34	Interface 'V ₁ ' adapter		Supplier specific
35	Spectrum Analyser	HP 8594E	
36	RF Switch	CX-600N	Toyo Tsusho
37	Oscilloscope	TDS 754A	Tektronix
38	Laboratory Test Management System	See SUBSET-085	
39	Laboratory Time and Odometer Module	See SUBSET-085	
40	Interface 'V ₂ ' Adapter		Supplier specific
44	Interface 'V _K ' Adapter		See Annex F on page 136
45	Low pass filter	See SUBSET-085	
46	Interface 'K' Adapter	See Annex D	Supplier specific ???

Annex C, Interface 'V_K'

C1 General

In order to be able to observe the transmission of Interface 'K' information, a specific test interface is required. The reasons are that transmission via the standardised Interface 'K' is performed using the RS 485 standard, that the bit rate is high, and that real time processing is not feasible in the LTMS. The obtained information needs to be fed back to the LTMS in a suitable high level format for succeeding evaluation.

This interface should be regarded as a dialect of the already existing Interface 'V₁' (defined in UNISIG SUBSET-085), but tailored to enable transmission of pre-evaluated Interface 'K' related data. This annex should be read together with the functionality and requirements of the Interface 'V_K' adapter defined in Annex F on page 136.

The Interface 'V_K' defines the data exchanged between the LTMS and the Interface 'V_K' adapter, in order to facilitate the tests defined in sections 4.2.4 through 4.2.6 of this specification. This interface requires the use of an Interface 'V_K' adapter in order to translate the required test data to formats and timings compatible with those of the equipment under test and the LTMS (see also Annex F on page 136).

C2 Configuration Data

C2.1 Test Case Selection (TESTCASE)

The test case selection data, included in the variable TESTCASE, is transmitted from the LTMS to the Interface 'V_K' adapter via the Interface 'V_K'. It is used to set the interface adapter in the appropriate mode such that it can evaluate the correctness of the data transmitted from the On-board ERTMS/ETCS Equipment via Interface 'K'. This includes transmission of the following information:

- Intended bit pattern
- Test Case
 - Radiation Pattern (RP)
 - Transmission Test (TT)
 - Functional Data, Case 1 (FD₁)
 - Functional Data, Tele-powering off (FD₂)
 - Functional Data, Eurobalise Reception (FD₃)
 - Functional Data, Up-link off (FD₄)
 - Functional Data, Tele-powering off (FD₅)
 - Normal Link Check (LC₁)
 - Link Check with ASK Up-link (LC₂)
 - Link Check with FSK Up-link (LC₃)
- Propagation delay in μs
- Used Architecture
- If optimally decoded data is provided or not
- If extended link check patterns are provided or not
- The expected Antenna/BTM ID Data to be received

The variable TESTCASE is a string of ASCII characters organised according to the structure shown in Table 23.

Char #	Meaning	Value
Char 1 to Char 2	<u>Bit Pattern (BP):</u> BP is a string of 2 ASCII characters (characters "0", "1", "2", ..., "9") defining of up to 99 pre-defined test patterns.	"BP ₁ " - Least significant bit "BP ₂ " - Most significant bit
Char 3	<u>Separator.</u>	"_"
Char 4	<u>Test Case (TC):</u> TC is a string of 1 ASCII character (characters "0", "1", "2", .., "9", "A", "F") defining of up to 16 pre-defined test cases.	"0" = RP "1" = TT "2" = FD ₁ "3" = FD ₂ "4" = FD ₃ "5" = FD ₄ "6" = FD ₅ "7" = LC ₁ "8" = LC ₂ "9" = LC ₃ "A" through "F" are spares
Char 5	<u>Separator.</u>	"_"
Char 6 to Char 8	<u>Propagation Delay (PD):</u> PD is a string of 3 ASCII characters giving the decimal number of the propagation delay (in μ s).	"H" – hundreds "D" – tens "U" – units
Char 9	<u>Separator.</u>	"_"
Char 10	<u>Architecture Type (AT):</u> AT is one ASCII character giving information on the applicable architecture. Up to 16 pre-defined configurations are possible.	"0" = One single channel "1" = Two diversified channels "2" = Two redundant channels "3" = Three redundant channels "4" = Two pairs of diversified channels "5" through "F" are spares
Char 11	<u>Separator.</u>	"_"
Char 12	<u>Data Type (DT):</u> DT defines if optimally decoded data is provided or not. DT is one ASCII character giving binary information on the applicable case.	"0" = Optimally decoded data is not provided "1" = Optimally decoded data is provided
Char 13	<u>Separator.</u>	"_"

Char #	Meaning	Value
Char 14 to Char 15	<u>Link Check Extension (LCE):</u> LCE gives information on how many additional (optional) bits are included in the link check pattern. LCE is a string of 2 ASCII character giving the decimal number. Zero means basic link check pattern.	“D” – tens “U” – units
Char 16	<u>Separator.</u>	“-“
Char 17	<u>Antenna/BTM ID Data (AID):</u> AID gives the information on which Antenna/BTM ID Data is supposed to be received. This is one ASCII character giving the information.	“0” = A ₁ set to 0 and A ₂ set to 0 “1” = A ₁ set to 1 and A ₂ set to 0 “2” = A ₁ set to 0 and A ₂ set to 1 “3” = A ₁ set to 1 and A ₂ set to 1

Table 23: TESTCASE variable structure

Note that communication of Link ID Data is not necessary since it only a matter of putting clear visible indications on the interface adapter which input is channel ‘a’, channel ‘b’, etc.

The LTMS sends a new TESTCASE variable each time it requires a new operating mode for the adapter. The LTMS waits for a maximum time of 1 s for receiving an answer, via the ADAPSTAT variable, confirming the switch to the requested operational mode.

The LTMS also checks that a coherent variable ALIVE is periodically and regularly transmitted approximately every 5 s from the interface adapter.

C2.2 Adapter Status (ADAPSTAT)

The status variable ADAPSTAT is sent by the Interface ‘V_k’ adapter to the LTMS as a response to a new configuration request issued by the LTMS (requested by means of a new TESTCASE variable). This response shall be issued within an overall delay time of 1 s after the test case selection order was issued.

The variable ADAPSTAT is a string of ASCII characters organised according to the structure shown in Table 24.

Char #	Meaning	Value
Char 1 to Char 3	<u>Header:</u> Company Acronym	“XYZ”
Char 4	<u>Separator.</u>	“-“
Char 5 to Char 6	<u>Bit Pattern Confirmation (BPC):</u> BPC is a string of 2 ASCII characters (characters “0”, “1”, “2”, ..., “9”) confirming one of up to 99 pre-defined test patterns.	“BP ₁ ” - Least significant bit “BP ₂ ” - Most significant bit
Char 7	<u>Separator.</u>	“-“
Char 8	<u>Test Case Confirmation (TCC):</u> TCC is a string of 1 ASCII character (characters “0”, “1”, “2”, ..., “9”, “A”, “F”) confirming one of up to 16 pre-defined test cases.	“0” = RP “1” = TT “2” = FD ₁ “3” = FD ₂ “4” = FD ₃ “5” = FD ₄ “6” = FD ₅ “7” = LC ₁ “8” = LC ₂ “9” = LC ₃ “A” through “F” are spares
Char 9	<u>Separator.</u>	“-“
Char 10 to Char 12	<u>Propagation Delay Confirmation (PDC):</u> PDC is a string of 3 ASCII characters confirming the decimal number of the propagation delay (in μs).	“H” – hundreds “D” – tens “U” – units
Char 13	<u>Separator.</u>	“-“
Char 14	<u>Architecture Type Confirmation (ATC):</u> ATC is one ASCII character confirming the applicable architecture. Up to 16 pre-defined configurations are possible.	“0” = One single channel “1” = Two diversified channels “2” = Two redundant channels “3” = Three redundant channels “4” = Two pairs of diversified channels “5” through “F” are spares
Char 15	<u>Separator.</u>	“-“

Char #	Meaning	Value
Char 16	<u>Data Type Confirmation (DTC):</u> DTC is one ASCII character confirming information on the applicable case.	“0” = Optimally decoded data is not provided “1” = Optimally decoded data is provided
Char 17	<u>Separator.</u>	“-“
Char 18 to Char 19	<u>Link Check Extension Confirmation (LCEC):</u> LCEC confirms how many additional (optional) bits are included in the link check pattern. LCEC is a string of 2 ASCII character giving the decimal number. Zero means basic link check pattern.	“D” – tens “U” – units
Char 20	<u>Separator.</u>	“-“
Char 21	<u>Antenna/BTM ID Data Confirmation (AIDC):</u> AIDC confirms which Antenna/BTM ID Data is supposed to be received. This is one ASCII character giving the information.	“0” = A ₁ set to 0 and A ₂ set to 0 “1” = A ₁ set to 1 and A ₂ set to 0 “2” = A ₁ set to 0 and A ₂ set to 1 “3” = A ₁ set to 1 and A ₂ set to 1

Table 24: ADAPSTAT variable structure

C2.3 Link Status (ALIVE)

The status variable ALIVE is periodically sent by the Interface 'V_K' adapter to the LTMS approximately every 5 s to confirm that the link with the LTMS is correctly working.

The correct behaviour of the link is indicated by a modulo 10 counter that is regularly incremented by 1 at each transmission. The status of this counter is contained in the ALIVE variable sent to the LTMS.

The ALIVE variable is a string of ASCII characters organised according to the structure shown in Table 25.

Char #	Meaning	Value
Char 1 to Char 3	<u>Header:</u> Company Acronym	"XYZ"
Char 4	<u>Mod. 10 counter:</u> Current value	"0", "1", "2", ..., "9"."0" ...

Table 25: ALIVE variable structure

C3 Test Data

C3.1 Test Report (TEST_REP)

After receiving data transmitted via Interface 'K', the adapter shall evaluate the correctness and consistency of the data, and transmit the result to the LTMS via Interface 'V_K'. There is a need for two different responses from the interface adapter dependent on which test case is in progress.

For test cases RP and TT, there should be a periodic transmission every reporting period including:

- Number of correct bits within the reporting interval

This consists of transmission of ASCII characters and constitutes the overall number of non-overlapping correct bits received between two subsequent reports to the LTMS (not the accumulated number of bits).

For all other test cases, there should be a periodic transmission every reporting period consisting of transmission of ASCII characters, where the characters represent:

- ERTMS Unavailable (true/false)
- Eurobalise Reception (true/false)
- Erroneous Link ID (true/false)
- Erroneous Antenna/BTM ID (true/false)
- Erroneous Bit Counter (true/false)
- Erroneous CRC (true/false)
- Permanent Failure (true/false)
- Link Check OK (true/false)
- FD₁ test OK (true/false)
- Signal Strength Data

The LTMS checks the logical consistency between the various fields of the TEST_REP variable transmitted by the Interface 'V_K' adapter.

The reporting period, could range between 50 ms and 600 ms.

The Interface 'V_K' adapter evaluates and converts the data, received from the Interface 'K', to the format prescribed for the TEST_REP variable, and then transmits it to the LTMS. The LTMS should have an internal buffering capability, in order to allow the LTMS to possibly postpone the on-line data elaboration, when it has to handle more urgent tasks than the Interface 'V_K' communication. The buffering is assumed to be dimensioned such that at least 20 s of test data can be received without losses, even when the interface adapter continuously transmits data for a prolonged time. The buffering can be of circular type. This implies that, during a continuous flow of test data, some of the data older than 20 s, can sporadically be lost by the LTMS.

In case the adapter is set in the mode of Radiation Pattern (RP) or Transmission Tests (TT), the TEST_REP_A variable is a string of ASCII characters organised according to the structure shown in Table 26.

Char #	Meaning	Value
Char 1 to Char 3	<u>Header:</u> Company Acronym	"XYZ"
Char 4	<u>Separator.</u>	"_"
Char 5 to Char 8	<u>Number of non-overlapping correct bits (CB):</u> CB is a string of 4 ASCII characters giving the decimal number of received telegrams.	"M" – thousands "H" – hundreds "D" – tens "U" – units

Table 26: TEST_REP_A variable structure for RP and TT cases

In case the adapter is set in any other mode than Radiation Pattern (RP) or Transmission Tests (TT), the TEST_REP_B variable is a string of ASCII characters organised according to the structure shown in Table 27.

Char #	Meaning	Value
Char 1 to Char 3	<u>Header:</u> Company Acronym	“XYZ”
Char 4	<u>Separator.</u>	“-“
Char 5	<u>ERTMS Unavailable:</u> True/false	“0” = false “1” = true
Char 6	<u>Eurobalise Reception:</u> True/false	“0” = false “1” = true
Char 7	<u>Erroneous Link ID:</u> True/false	“0” = false “1” = true
Char 8	<u>Erroneous Antenna/BTM ID:</u> True/false	“0” = false “1” = true
Char 9	<u>Erroneous Bit Counter:</u> True/false	“0” = false “1” = true
Char 10	<u>Permanent Failure:</u> True/false	“0” = false “1” = true
Char 11	<u>Link Check OK:</u> True/false	“0” = false “1” = true
Char 12	<u>FD₁ test OK:</u> True/false	“0” = false “1” = true
Char 13 to Char 14	<u>Signal Strength Data (SS):</u> SS is a string of 2 ASCII characters giving the decimal representation of the reported signal strength (range 0 through 15).	“D” – tens “U” – units

Table 27: TEST_REP_B variable structure for all cases except RP and TT

C4 Physical Control

C4.1 General

The media for Interface 'V_K' shall be two twisted shielded pairs of wires. The nominal characteristic impedance of the cable shall be 120 Ω.

The interfaces shall fulfil the requirements of the RS485 standard.

The connector layout and the disposition of the connector in the interface adapter may be dependent on the actual selection of commercial hardware.

C4.2 Architecture

The following general architecture applies for connecting the On-board system under test to the test environment via Interface 'V_K'.

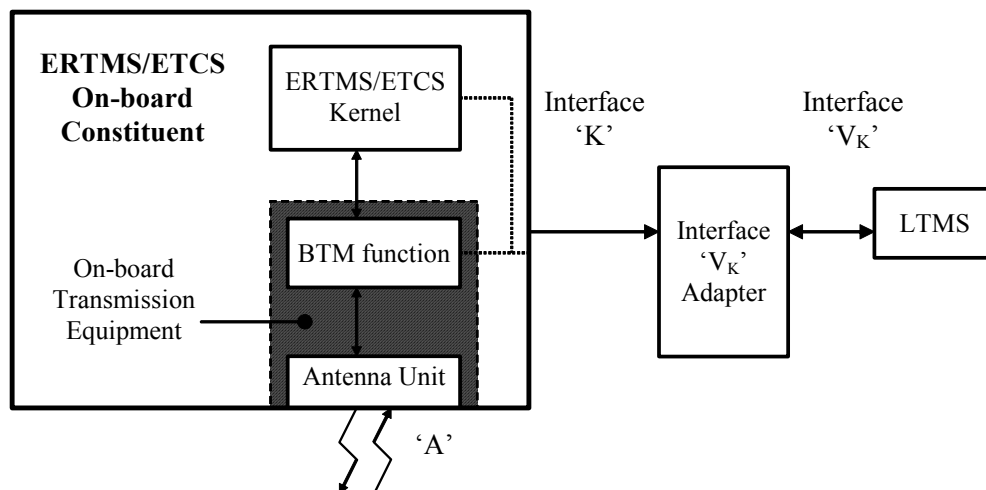

Figure 20: Architecture

The data to be exchanged between the Interface 'V_K' adapter and the test environment (in this case the LTMS) is defined in chapter C2 on page 114 and chapter C3 on page 119.

In general, interaction via Interface 'V_K' is defined through the following variables:

- Test Case Selection
- Adapter Status
- Link Status
- Test Report

The variables are of various lengths, and no checksum mechanism is defined on that level. The variables are transmitted on a one by one basis at various repetition rates or instants.

C4.3 Interface ‘V_K’, Mechanical Data

DSUB connectors with 9 pins/sockets shall be used.

Connector layout:

Interface Adapter side ⁷		LTMS side	
Pin	Signal	Pin	Signal
	Positive Adapter Transmit terminal	1	Ground
	Negative Adapter Transmit terminal	2	Ground
	Ground	3	Unconnected
	Positive LTMS Transmit terminal	4	Positive Adapter Transmit terminal
	Negative LTMS Transmit terminal	5	Negative Adapter Transmit terminal
		6	Unconnected
		7	Unconnected
		8	Positive LTMS Transmit terminal
		9	Negative LTMS Transmit terminal

Table 28: Pin Configuration for Interface ‘V_K’

The cable connector in the LTMS end of the cable shall be of female type.

The cable connector in the Interface Adapter end of the cable shall be of male type.

Note: Adequate termination shall be performed in the LTMS (a load resistor shall be connected between pins 4 and 5 of the LTMS cable connector).

⁷ The actual configuration with respect to pinning and disposition of the connector in the Interface Adapter may be dependent on the actual selection of commercial hardware.

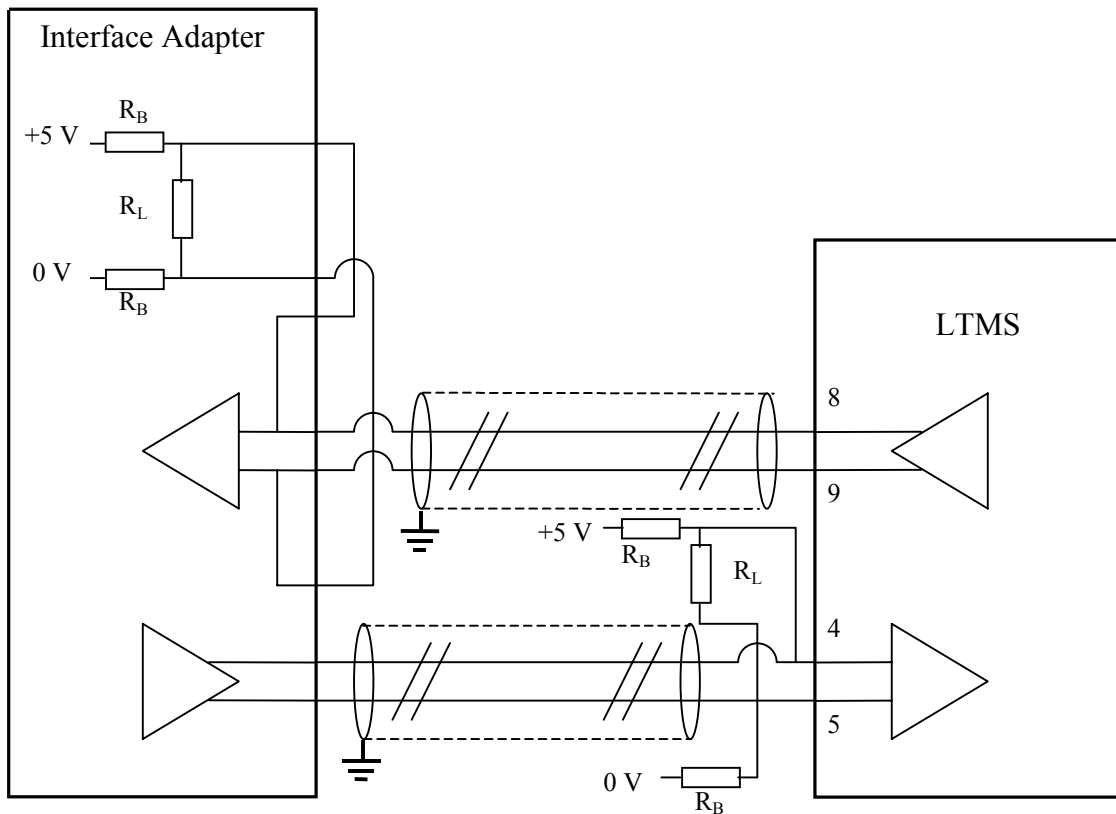

Figure 21: Physical Configuration for Interface 'Vκ'

The load resistance R_L shall be $110 \Omega \pm 10 \Omega$.

The biasing resistors R_B shall be $650 \Omega \pm 30 \Omega$.

Please observe that the actual configuration with respect to pinning and disposition of the connector in the Interface Adapter may be dependent on the actual selection of commercial hardware. The load and biasing resistors indicated inside the Interface Adapter may also be external to the Interface Adapter (similarly to the LTMS side).

C5 Link Control

C5.1 General

The used communication channels shall be RS485. The applicable port configuration shall be:

- Data Rate 115.2 kbit/s
- Idle state of the channels at the high level (logical 'one')
- No Parity
- One start bit (a 'zero')
- 8 data bits (direct NRZ encoding)
- One stop bit (a 'one')

The channel for Interface 'V_K' shall constitute full duplex communication. No handshaking shall be used.

C5.2 Interface 'V_K'

The variables defined in chapter C2 on page 114 and chapter C3 on page 119 shall be transmitted on a one by one basis. Each variable shall be preceded by a unique header, a sequence number, and information on length of data, and shall be succeeded by a 32-bit CRC. This is illustrated as follows.

Header (1 byte)	Seq. Number (1 byte)	Length of Data (2 bytes)	Variable (X bytes)	CRC (4 bytes)
--------------------	-------------------------	-----------------------------	-----------------------	------------------

The header before the package of variables (and before the 'Length of Data' and 'Seq. Number' fields) shall be one byte long and consist of a unique value for each variable as defined below.

The 'Length of Data' field shall be two bytes long and include the number of data bytes in the 'Variable' field (which in this case is as recalled below). The most significant byte shall be transmitted first.

The 'Seq. Number' field shall be one byte long and include a counter (individual for each variable) that is incremented by one each time the variable is transmitted. The variable shall be a modulo 256 counter (counting 0 to 255), which is initialised to zero at power on or if the interface adapter is reset.

The 'Variable' of the succeeding field has the following length, and shall be announced by the below defined header:

- | | | |
|----------------------------------|------------|-------------------------------|
| • Test Case Selection (TESTCASE) | Header = 0 | Length of Data = 17 (decimal) |
| • Adapter Status (ADAPSTAT) | Header = 1 | Length of Data = 21 (decimal) |
| • Link Status (ALIVE) | Header = 2 | Length of Data = 4 (decimal) |
| • Test Report (TEST_REP_A) | Header = 3 | Length of Data = 8 (decimal) |
| • Test Report (TEST_REP_B) | Header = 4 | Length of Data = 14 (decimal) |

The concluding 'CRC' shall be calculated over the overall bit stream of each transmission (i.e., the fields 'Header', 'Seq. Number', 'Length of Data', and 'Variables'), before the inclusion of start and stop bits, using the following generator polynomial:

$$X^{32} + X^{30} + X^{27} + X^{25} + X^{22} + X^{20} + X^{13} + X^{12} + X^{11} + X^{10} + X^8 + X^7 + X^6 + X^5 + X^4 + X^0$$

For the purpose of initialisation of the 32 bit shift register for the generator polynomial, the pattern 0x00FF0000 (most significant bit least significant bit) applies.

The data flow is from most significant byte to least significant byte of each variable. The least significant bit is transmitted first for each byte.

If the LTMS detects the loss of data packages (using the 'Seq. Number') or detects corruption of data (through evaluation of the CRC), it shall terminate the test that is in progress, and re-start the test.

C6 Link Synchronisation

C6.1 General

There are four different scenarios where the synchronisation mechanism applies:

- During an initial switching ON sequence. There are two possibilities:
 - Case 1 – The Interface 'V_K' adapter is switched on before the Interface 'V_K' driver in LTMS
 - Case 2 – The Interface 'V_K' driver in LTMS is switched on before the Interface 'V_K' adapter
- During re-starting scenarios. There are two possibilities:
 - Case 3 – The Interface 'V_K' driver in LTMS is re-started but the Interface 'V_K' adapter remains on
 - Case 4 – The Interface 'V_K' adapter is re-started but the Interface 'V_K' driver in LTMS remains on

The general mechanism used by the Interface 'V_K' driver in LTMS to synchronise with the Interface 'V_K' adapter is that for each ADAPSTAT, ALIVE, or TEST_REP variable, whose internal sequence number (i.e., the sequence number stored by the Interface 'V_K' driver that is received from the Interface 'V_K' adapter) is equal to 0, the Interface 'V_K' driver updates itself with the sequence number (SN) received from the Interface 'V_K' adapter. See also section C6.6 on page 131.

C6.2 The Interface Adapter is switched on before the Interface 'V_K' driver

This is referred to as Case 1, and is the normal situation. As shown in Figure 22, the Interface 'V_K' driver internally synchronises with the ALIVE variable, thus modifying its sequence number.

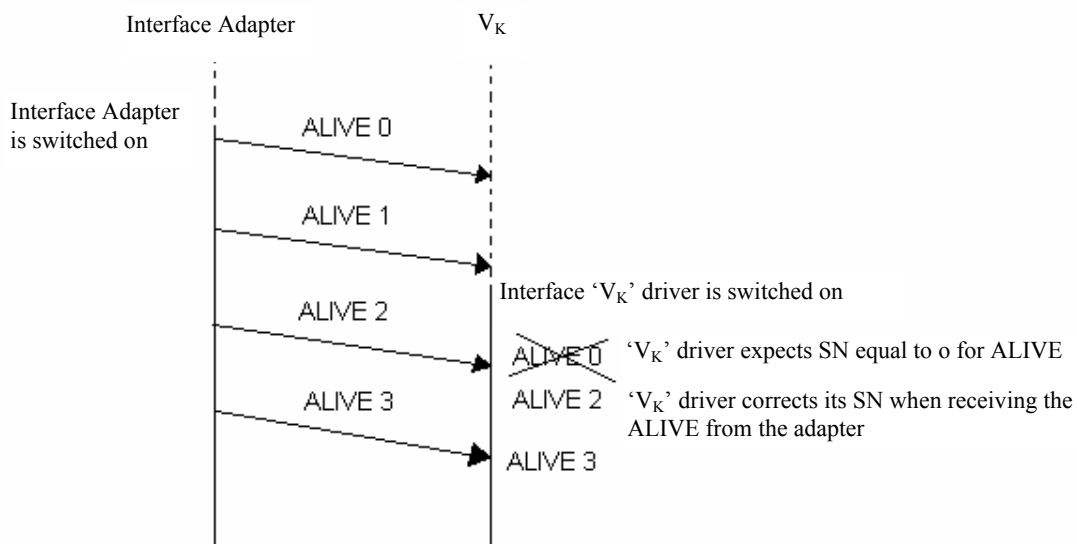

Figure 22: Case 1

C6.3 The Interface 'V_K' driver is switched on before the Interface Adapter

This is referred to as Case 2, which is not a normal case because the interface adapter is normally switched on before the Interface 'V_K' driver. However, it might happen, and then the interface adapter shall be able to synchronise with the Interface 'V_K' driver. As shown in Figure 23, the Interface 'V_K' driver waits for some time to receive the ALIVE status from the interface adapter. It gives a time out error after some time as no ALIVE variable has been received.

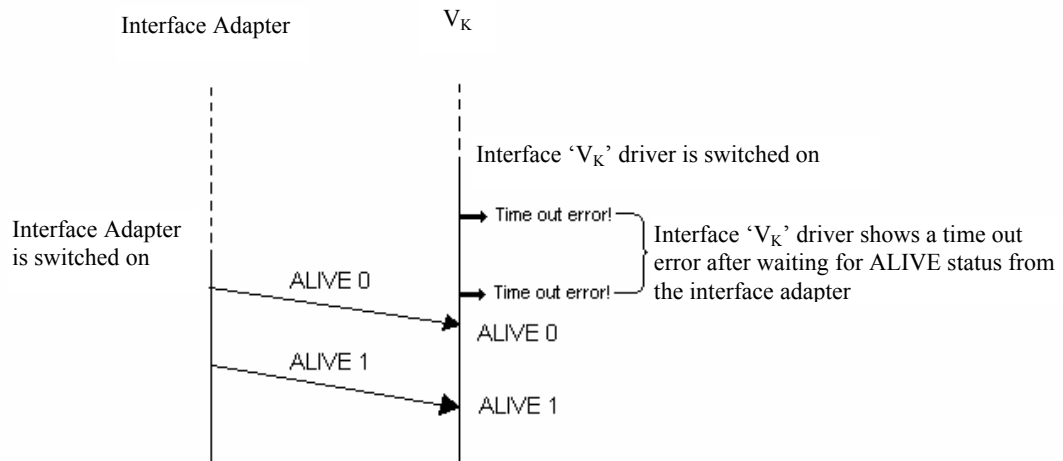

Figure 23: Case 2

C6.4 The Interface 'V_K' driver is re-started but the Interface Adapter remains on

This case could happen sometimes. If a test procedure has finished and a new one is started, the interface adapter remains on whereas the Interface 'V_K' driver is closed in the first test procedure and re-opened again in the second one. The Interface 'V_K' driver needs to synchronise with the interface adapter.

As shown in Figure 24, the Interface 'V_K' driver is re-started at some point of time. The first time the Interface 'V_K' driver receives a variable from the interface adapter, the Interface 'V_K' driver internally synchronises with the variable in a similar way as in Case 1. This normally happens with ALIVE, ADAPSTAT, and TEST_REP variables.

When the Interface 'V_K' driver sends a TESTCASE variable after being re-started, the interface adapter is the one that synchronises with the Interface 'V_K' driver as shown in Figure 25. The interface adapter does not answer with a ADAPSTAT variable the first time. This is due to synchronisation mechanism. The interface adapter needs a second TESTCASE variable to continue the communication.

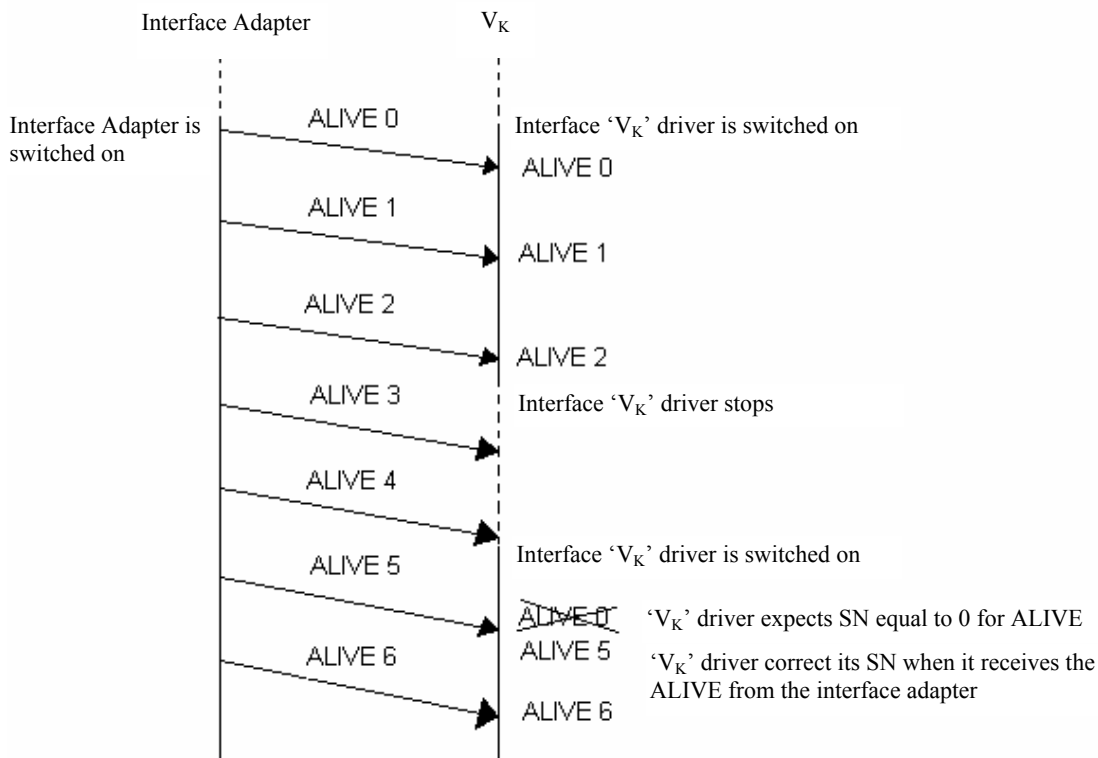

Figure 24: Case 3, ALIVE variable

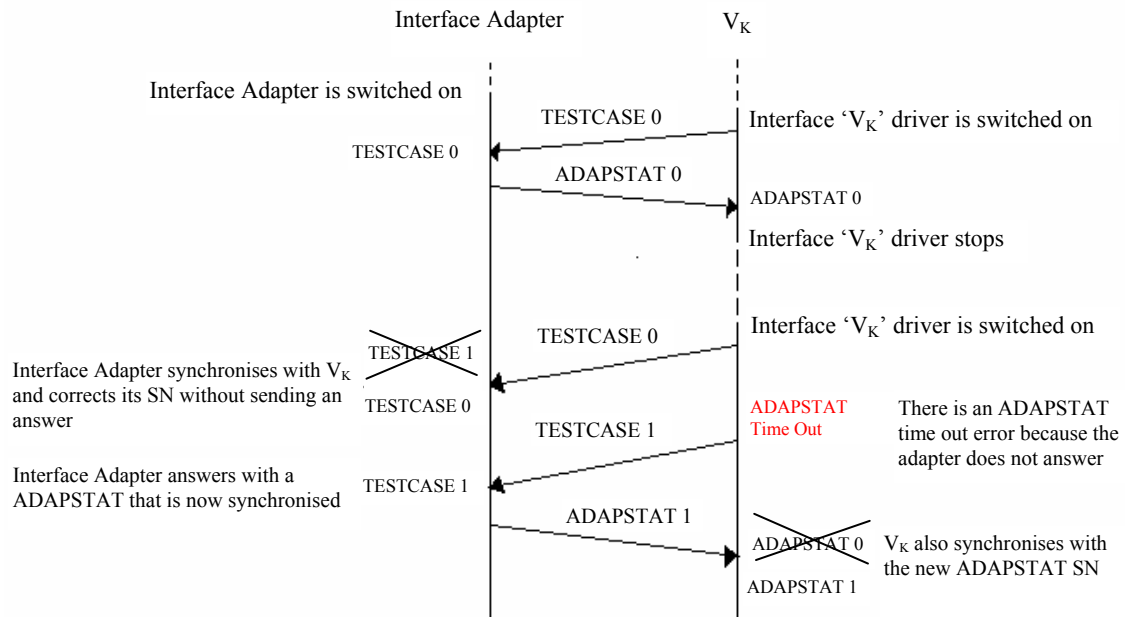

Figure 25: Case 3, TESTCONF variable

It should be considered that the Interface 'V_K' adapter behaviour may depend on implementation. This description only intends to clarify the behaviour of the Interface 'V_K' driver.

Refer to the description of the synchronisation mechanism in section C6.6 on page 131 to understand all the possible situations.

C6.5 The Interface Adapter is re-started but the Interface 'V_K' driver remains on

This case (referred to as Case 4) is an abnormal situation from the test procedure point of view. If the Interface 'V_K' driver is active, this is because the test procedure is under execution. While the test procedure is running the interface adapter cannot be restarted. If the interface adapter is restarted during a test procedure, this is due to an interface adapter failure. In that case, the test procedure should stop and re-start again with a correctly operating interface adapter.

The interface adapter, and the Interface 'V_K' driver, are re-started and synchronise according to Case 1.

C6.6 Behaviour of the Interface 'V_K' driver

The following behaviour is assumed to be implemented in the Interface 'V_K' driver in the LTMS.

1. The Interface 'V_K' driver sends a TESTCASE variable and waits for the corresponding ADAPSTAT variable from interface adapter.

If ADAPSTAT is received, the Interface 'V_K' driver:

- Displays the received status in the button indicators.
- The first time (Interface 'V_K' SN = 0), it does not check the SN of ADAPSTAT answer, but it updates its own SN with the new one coming from the interface adapter. No error is displayed. In all the subsequent cases it checks the incoming SN and, if different from its own, it displays "Stat Sequence Number" error.
- If ADAPSTAT has a status different from the requested TESTCASE status, there is an error message "ADAPSTAT error", and the button indicators appear shaded.
- If ADAPSTAT is received outside the Time out, it displays "Stat Time out" error.

If ADAPSTAT is not received, the Interface 'V_K' driver:

- Displays the error "Stat Time out".
- Displays the error "ADAPSTAT error".

2. The Interface 'V_K' driver waits continuously for interface adapter alive status.

When ALIVE is received by the Interface 'V_K' driver, it:

- Displays the three characters of the company acronym plus the "Mod 10 counter" in the ALIVE display.
- The first time (Interface 'V_K' SN = 0) it does not check the SN of "Alive", but it updates its own status with the new one coming from the interface adapter. No error is displayed. In all the subsequent cases, it checks the incoming SN and, if different from its own, it displays "Alive Sequence Number" error.
- The first time (Interface 'V_K' SN = 0) it does not check the "Mod 10 counter" of ALIVE, it but it updates its own status with the new one coming from the interface adapter. No error is displayed. In all the subsequent cases, it checks the incoming "Mod 10 counter" of "Alive" and, if different from its own, it displays "Alive Modulo 10" error.
- The first time (Interface 'V_K' SN = 0) it does not check if it is received within ALIVE period + tolerance. No error is displayed. In all the subsequent cases, it checks if it is received within the Alive period + tolerance.

If ALIVE is not received or is received outside the Alive period \pm tolerance, "Alive period" error is displayed.

3. The Interface 'V_K' driver continuously checks if TEST_REP is received from the interface adapter.

When TEST_REP is received, the Interface 'V_K' driver:

- Displays the received variable in the TEST_REP table.
- The first time (Interface 'V_K' SN = 0) it does not check the SN of TEST_REP, but it updates its own status with the new one coming from the interface adapter. No error is displayed. In all the subsequent cases, it checks the incoming SN and, if different from its own, displays "Test Report Sequence Number" error.

Annex D, Interface ‘K’ Adapter

D1 General

The herein given suggestions constitute general architectural guidelines for designing the Interface ‘K’ adapter. The key issue is to facilitate short test time. Thus data transfer from a compute platform should be minimised and the transferred information should be such that hardware oriented modules should be able to select and repeat reasonably short pattern in order to generate the required sequences. Commercially available instruments are preferred as far as possible, but certain modules most likely need to be specifically developed.

D2 Functional Requirements

In order to facilitate testing as defined in chapter 5 of this specification, the Interface ‘K’ adapter needs to provide the following functionality related to the alternative 1 interface:

- Generation of extreme ASK bit data rate
- Generation of extreme phase differences between channels
- Generation of extreme jitter in the Bi-phase Level clock generation
- Generation of correct and erroneous number of stop bits
- Generation of various combinations of “data” (BD, TD, EU, EB, LT, S, A, and L data)
- Generation of correct and erroneous Bit Counter data (B data)
- Generation of correct and erroneous CRC
- Generation of correct Link Check pattern
- Generation of Link Check pattern with corrupt CRC
- Generation of Link Check patterns with other imperfections in “data”

For supporting the alternative 2 interface, the following functionality needs to be provided:

- Generation of extreme ASK bit data rate
- Generation of extreme phase differences between channels
- Generation of extremes regarding the relation between “data” and “CLK”
- Generation of suitable “data”
- Generation of indication of Eurobalise
- Generation of link tests

D3 Suggested Block Diagram, Alternative 1

The block diagram according to Figure 26 below is suggested for the Interface 'K' Adapter supporting the alternative 1 interface. Please note that the architecture is tailored for enabling short test time.

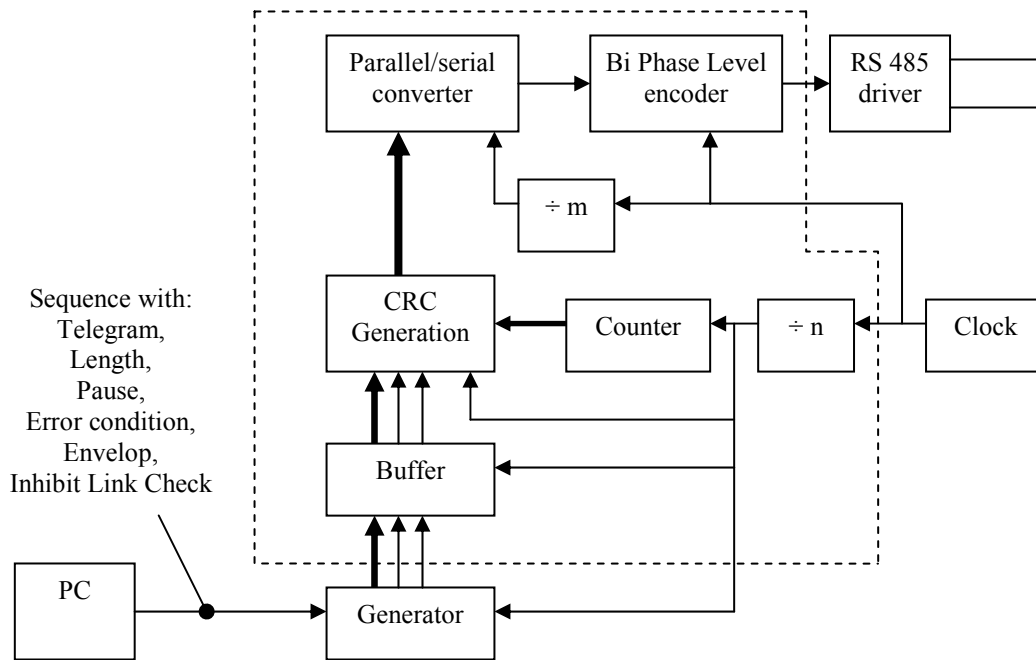

Figure 26: Block Diagram for Interface 'K' Adapter

The items within the dashed "box" are probably specifically developed HW modules.

There will also be a need for a specific S/W tool that is able to automatically generate the sequences that should be loaded into the generator.

Annex E, Tools needing extended functionality

E1 General

The majority of the tools are already defined in the documentation for Eurobalise (UNISIG SUBSET-085). However, some of the existing tools need extended functionality in order to facilitate testing of the Interface 'K' functionality.

This annex details what additional functionality and requirements are required for the already existing tools.

E2 Laboratory Management System (LTMS)

E2.1 General

The herein defined additions apply to UNISIG SUBSET-085 in order to support the functionality required by the LTMS for the testing defined in this specification.

In general terms, the LTMS needs bidirectional communication with the Interface 'V_K' adapter in order to set the adapter to required modes/status, and to receive test results.

E2.2 External Interfaces

The LTMS needs a new external interface for communicating with the Interface 'V_K' adapter. This interface is similar to the existing interface with the Interface 'V1' adapter, but other information is communicated. The interface is defined in Annex C on page 114.

E2.3 Test Sequences

The LTMS needs to provide new test sequences with related evaluation supporting the test procedures defined herein, supporting the Interface 'V_K' as defined in Annex C on page 114, and supporting the principles applicable to the Interface 'V_K' adapter as defined in Annex F on page 136.

E3 Reference Signal Generator (RSG_1)

E3.1 General

The herein defined additions apply to UNISIG SUBSET-085 in order to support the functionality required by the RSG_1 for the testing defined in this specification.

In general terms, additional signals are needed for supporting generation of ASK Up-link signals and generation of suitable marker indicating transmission of a 'zero' ASK bit.

The RSG_1 needs to generate Up-link ASK test waveforms in addition to FSK test waveforms. The generation of the ASK patterns must be synchronised with the modulation pulses of the Tele-powering signal.

E3.2 External Interfaces

The RSG_1 needs to provide an additional marker suitably indicating the start of a 'zero' ASK bit. This marker shall be sent to the Interface 'V_K' adapter.

The RSG_1 needs to receive a signal synchronising the generation of the Up-link signal with the modulation pulses of the Tele-powering signal from the On-board Equipment under test.

All this is defined in Figure 4 on page 16 and Figure 5 on page 16. Additionally, the delay between the modulation pulses in the air-gap and the generation and indication of the start of the ASK bit shall be adjustable within the RSG_1. See section 4.1.7 on page 24.

E3.3 Required Performance

The RSG_1 needs to support the ranges specified in UNISIG SUBSET-100 with respect to the following ASK specific parameters:

- Up-link Carrier Frequency
- Decay time t_{50}
- Amplitude Jitter
- Delay Time $t_{pudelay}$ (please observe that synchronisation with the modulation pulses of the Tele-powering signal is required)
- Data Rate (50 kHz, synchronised with the modulation pulses of the Tele-powering signal)

The static synchronisation between the modulation pulses in the Tele-powering signal and the generation of the ASK bit pattern shall be better than 50 ns <TBC>, and the maximum allowed jitter in the generation of the data shall be better than 5 ns <TBC>.

Annex F, Interface ‘V_K’ Adapter

F1 General

This annex details the requirements and functionality related to the Interface ‘V_K’ adapter.

F2 Functional Requirements

F2.1 General

The herein stated test cases are further defined in sections 4.2.4 through 4.2.6 of this specification.

The Interface ‘V_K’ adapter shall comply with the requirements defined for Interface ‘V_K’ in Annex C on page 114.

The Interface ‘V_K’ adapter shall comply with the applicable requirements defined for Interface ‘K’ in UNISIG SUBSET-101. Since there are two alternative interfaces, the adapter may either be realised as one dedicated to the so-called Alternative 1, and another to Alternative 2, or both alternatives may be integrated in the same adapter.

The Interface ‘V_K’ adapter shall support the full scope of architecture variants defined in UNISIG SUBSET-101.

F2.2 Radiation Pattern Test and Transmission Tests

During “Radiation Pattern test” and “Transmission Tests”, the adapter needs the information that these tests are commanded by the LTMS, and must be given the possibility to periodically report the number of correctly received bits during the contact between the Reference Loop and the On-board equipment.

Therefore, the LTMS shall communicate the test cases “Radiation Pattern” or “Transmission Test” to the adapter, together with the information on the bit sequences intended to be transmitted. The bit sequence information shall be communicated in order to make it possible for the adapter to evaluate the response from the ERTMS equipment.

The adapter shall provide periodical reporting of “Number of correctly received bits” (e.g., each 100 ms period). This specific periodical reporting shall be linked to when the adapter is ordered into either “Radiation Pattern test” or “Transmission Tests” modes.

F2.3 Functional Data Tests

The functional data tests are split into five different sub-tests requiring various needs of functionality and communication. These are:

- Functional Data case 1 (FD₁)
- Functional Data Tele-powering off (FD₂)
- Functional Data Eurobalise Reception (FD₃)
- Functional Data Up-link off (FD₄)
- Functional Data Permanent Error (FD₅)

Regarding FD₁, information on the intended bit pattern, and on the test case “FD₁”, need to be communicated to the adapter. The adapter also needs to be suitably triggered by the RSG in order to be able to evaluate a specific instant where ‘one’ and ‘zero’ data is expected. The adapter also needs to get the information on the actual propagation delay from the air gap to Interface ‘K’ (evaluated in a previous test).

The adapter shall perform the evaluation defined in the first step of section 4.2.4.4 on page 30 or section 4.3.4.4 on page 59 (dependent on which interface alternative apply), and communicates “FD₁ test OK” together with the actual Signal Strength value.

Regarding FD₂, information on the test case “FD₂”, needs to be communicated to the adapter. The LTMS switches the Tele-powering off (via Interface ‘V₁’) and shall receive “ERTMS Unavailable” information from the interface adapter within no more than approximately 1 s (a reasonable observation interval for test purposes).

Regarding FD₃, information on the test case “FD₃”, needs to be communicated to the adapter. The LTMS starts transmitting FSK Up-link signal, and shall receive “Eurobalise Reception” as a response. The adapter shall by itself evaluate when FSK reception starts, and also evaluate the defined timing requirements related to when the ERTMS has recognised that Eurobalise reception is in progress.

Regarding FD₄, information on the test case “FD₄”, needs to be communicated to the adapter. The LTMS starts the sequence with transmitting Up-link signals, and switches the transmission off at suitable instant. The adapter shall recognise when transmission is aborted, and shall verify that correct link check pattern is received within 250/500 ms (dependent on which interface alternative apply). If this criterion is fulfilled, the information on “Link Check OK” shall be transmitted to the LTMS.

Regarding FD₅, information on the test case “FD₅”, needs to be communicated to the adapter. The test will be performed in a semi manual way such that the LTMS orders the operator to introduce a suitable error (e.g., unplugging the antenna). Thereafter, the adapter shall transmit “Permanent Error” to the LTMS when it has detected that there is no activity on Interface ‘K’. A reasonable observation interval for test purposes is 1 s (after the actual introduction of the failure).

During these tests, the adapter shall perform periodical reporting (e.g., each 100 ms period), communicating the appropriate information as defined in section C3.1 on page 119.

F2.4 Link Check Functionality Tests

The link check functionality tests are split into three different sub-tests requiring various needs of functionality and communication. These are:

- Normal Link Check (LC₁)
- Link Check with ASK (LC₂)
- Link Check with FSK (LC₃)

Regarding LC₁, information on the test case “LC₁”, needs to be communicated to the adapter. The adapter shall perform the evaluation that correct link test patterns are received according to the definitions of UNISIG SUBSET-101 and the definitions within this specification. The interface adapter shall communicate “Link Check OK” as long as the criteria are fulfilled (and otherwise “Link Check NOK”).

Regarding LC₂, information on the intended bit pattern, and on the test case “LC₂”, need to be communicated to the adapter. The LTMS also orders transmission of “continuous” ASK Up-link signal. The adapter shall perform the evaluation and reporting as defined for functional data FD₁, and shall verify that Balise data reception is aborted by a correct link check pattern after a time greater than 0.5 s but no later than 1 s after the start of the test. In the reporting interval succeeding the instant when the link check pattern was correctly detected, the adapter shall transmit “Link Check OK” to the LTMS. “Link Check NOK” shall be transmitted during Balise reception and in case no correct link check is detected (both in terms of pattern and in terms of timing).

Regarding LC₃, the mechanisms are identical to LC₂ with the exception that FSK Up-link signal is transmitted.

During these tests, the adapter shall perform periodical reporting (e.g., each 100 ms period), communicating the appropriate information as defined in section C3.1 on page 119.

F3 Physical requirements

F3.1 Interface 'K' Connectors

DSUB connectors of male type with 9 pins shall be used in the Interface 'V_K' adapter.

Connector layout:

Interface 'V _K ' Adapter side	
Pin	Signal
4	Positive Adapter Receive terminal
5	Negative Adapter Receive terminal
3	Ground
8	Load Connection
9	Load Connection
6	Positive Adapter Receive terminal
7	Negative Adapter Receive terminal

Table 29: Pin Configuration for Interface 'K'

Note that this pinning applies to a specific RS 485 board. Other boards may be selected, and the pinning could be suitable re-defined. However, in this case a suitable adapter shall be provided enabling the pinning of Table 29.

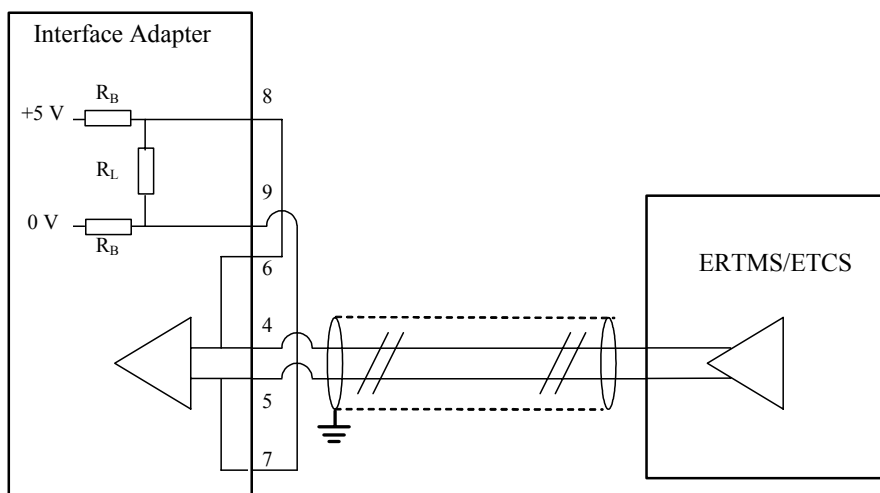

Figure 27: Physical Configuration for Interface 'K'

The load resistance R_L shall be $110 \Omega \pm 10 \Omega$.

The biasing resistors R_B shall be $650 \Omega \pm 30 \Omega$.

F3.2 Connector for trigger from RSG_1

A standard chassis BNC connector shall be used.

F4 Electrical requirements

F4.1 General

The Interface 'V_K' adapter serial channels shall comply with the requirements of RS 485.

F4.2 Isolation

The input stages of the RS 485 receivers shall provide galvanic isolation between the device under test and the test environment.

F4.3 Trigger from RSG_1

The trigger signal from the RSG_1 is assumed to fulfil the following requirements.

- Pulse with low signal level of 0 V and high signal level of 2 V at 50 Ω load.
- Pulse width of 100 μ s
- Rising edge is active edge.