

ERTMS/ETCS – CLASS 1

FFFIS for Euroloop

REF : SUBSET-044

ISSUE : 2.3.0

DATE : 2008-02-05

Company	Technical Approval	Management Approval
ALSTOM		
ANSALDO		
BOMBARDIER		
INVENSYS		
SIEMENS		
THALES		



1 MODIFICATION HISTORY

Issue Number Date	Section number	Modification / Description	Author
0.1.0 / 1999-10-05	All	Corrections after review	B. Stamm
1.0.0 / 1999-10-14	All	Version for release	B. Stamm
1.1.0 / 2000-01-31	All	Minor corrections for 2 nd release	B. Stamm
2.0.0 / 2000-03-30	3.3	Final issue to ECSAG	U.D. (ed)
2.0.1 / 2004-09-23	All	New centre frequency of $f_c = 13.54750$ MHz Integration of the SUBSETs 043, 045, and 050.	H. Duran, D. Rieder, E. Zollinger
2.0.2 / 2004-09-28	All	Corrections after review	H. Duran, E. Zollinger
2.1.0 / 2004-09-29	All	Final issue approved	A. Bruehwiler
2.1.1 / 2005-03-11	All	Corrections after informal review	E. Zollinger
2.1.2 / 2005-05-04	All	Corrections after review	Ernst Zollinger
2.1.3 / 2005-06-10	All	Including comments, from UNISIG meeting of 25./26. 05. 2005	Ernst Zollinger
2.1.4 / 2005-07-01	All	Including comments from UNISIG meeting of 21./22. 06. 2005	Ernst Zollinger
2.1.5 / 2005-07-10	All	Including review comments from UNISIG meeting of 13./14. 07. 2005	Ernst Zollinger
2.1.6 / 2005-09-14	All	Including comments from UNISIG meeting of 06./07. 09. 2005	Ernst Zollinger
2.1.7 / 2005-09-27	All	Including comments from UNISIG	Ernst Zollinger
2.1.8 / 2005-10-04	All	Including comments from UNISIG	Ernst Zollinger
2.2.0 / 2005-10-12	All	Final issue approved by UNISIG	Ernst Zollinger
2.2.1 / 2007-10-09		Including modification according to change request	Max Loder
2.2.2 / 2008-01-15		Including comments from UNISIG	Max Loder
2.3 / 2008-02-05		Including comments from UNISIG	Max Loder
2.3.0 / 2009-04-02		New template only	David Gillan

© This document has been developed and released by UNISIG



2 TABLE OF CONTENTS

1	MODIFICATION HISTORY	2
2	TABLE OF CONTENTS	3
3	GENERAL	7
3.1	Foreword	7
3.2	Normative References	7
3.3	Scope	9
4	ABBREVIATIONS AND DEFINITIONS	10
4.1	Introduction	10
4.2	Abbreviations	10
4.3	Definitions	13
5	EUROLOOP SUBSYSTEM	15
5.1	Architectural Layout	15
5.1.1	Euroloop within ERTMS/ETCS	15
5.1.2	Interfaces Overview	16
5.2	Functional Requirements	18
5.2.1	Extension of Eurobalise Functions	18
5.2.2	Identification and Activation of Trackside Equipment	18
5.2.3	Coupling and Modulation	18
5.2.4	Multiple Trackside Equipment or On-board Equipment in Operation	19
5.2.5	Coding Requirements	19
5.2.6	Reliable Data Transmission	19
5.2.7	Telegram Switching	19
5.3	Performance Requirements	20
5.3.1	Train Speed	20
5.3.2	System Response Times	20
5.4	RAMS Requirements	21
5.4.1	General	21
5.4.2	Top Level Functionality	21
5.4.3	Reliability	21
5.4.4	Availability	22
5.4.5	Maintainability	24
5.4.6	Safety	24
5.5	Geometrical Reference	29
5.5.1	Coordinate System	29
5.5.2	Reference Position	29
6	TRACKSIDE EUROLOOP SUBSYSTEM	30
6.1	Architectural Layout	30
6.1.1	Trackside Equipment	30
6.1.2	Sub-Sections	30

© This document has been developed and released by UNISIG

6.1.3	Arrangements	30
6.2	Functional Requirements	33
6.2.1	End of Loop Marker (EOLM)	33
6.2.2	Assignment of Spreading Code	33
6.2.3	LOOMO's Modes of Operation	33
6.2.4	Activation and Deactivation of LOOMO	33
6.2.5	Deactivation Bit Pattern	34
6.3	Interface 'C_{L1}' - Up-link Data from LEU to LOOMO	35
6.3.1	Overview	35
6.3.2	Data Rate	35
6.3.3	Telegram Lengths	35
6.3.4	Coding Requirements	35
6.3.5	Functional Requirements	36
6.3.6	Handshaking and Re-Sending	36
6.3.7	Eye Diagram	36
6.4	Interface 'C_{L2}' – Error Indication of LOOMO	38
6.5	Interface 'C_{L3}' – External Activation of LOOMO	39
6.6	Interface 'C_{L6}' – External Power Source of LOOMO	39
6.7	Interface 'CA_L' - Up-link Data from LOOMO to ELC	40
6.7.1	Overview	40
6.7.2	Line Receiver Function	40
6.7.3	Loop Modulator Function	40
6.7.4	Maximum Time Interval Error	43
6.7.5	Raw Carrier	44
6.7.6	Quality of LOOMO's Output Signal	44
6.7.7	Spectrum Mask	47
6.7.8	Impedance and Return Loss	47
6.8	Air Gap Interface	48
6.8.1	Overview	48
6.8.2	Interface 'A _{L4} ' – Euroloop Activation	48
6.8.3	Interface 'A _{L1} ' - Up-link Data Transmission	51
6.9	Environmental Conditions	53
6.9.1	General Conditions	53
6.9.2	Sealing, Dust and Moisture	53
6.9.3	Debris (Informative)	53
6.10	Trackside Installation Rules	54
6.10.1	Maximum Length of Loop Sections	54
6.10.2	Minimum Length of Loop Section	54
6.10.3	Distance between EOLM and Loop Section	54
6.10.4	Minimum Distance between Loop Sections with Same Q_SSCODE	54
6.10.5	Signal-to-Interference Ratio	54
6.10.6	Euroloop Leaky Cable Requirements	55
6.10.7	Installation of Euroloop Leaky Cable	57
6.10.8	Assignment of Spreading Code	58
6.10.9	Quality of Installation	58
6.11	Specific Electrical Requirements	59
6.11.1	General	59

6.11.2	Protective Provisions Relating to Electrical Safety and Earthing	59
6.11.3	Insulation Co-Ordination	59
6.11.4	Dielectric Tests	59
6.12	Test Requirements.....	60
6.12.1	General	60
6.12.2	Test Signals	60
6.12.3	Test Tools	60
6.12.4	Test Mode	61
6.13	EMC Requirements	62
6.13.1	Emission – Excluding Aspects Related to the Air Gap	62
6.13.2	Emission – Aspects Related to the Air Gap	62
6.13.3	Immunity	62
7	ON-BOARD EUROLOOP SUBSYSTEM	63
7.1	Architectural Layout.....	63
7.2	Functional Requirements.....	64
7.2.1	Loop Receiver Function.....	64
7.2.2	Loop Decoder Function	64
7.3	Air Gap Interfaces.....	65
7.3.1	Overview	65
7.3.2	Interface ‘A _{L1} ’ - Air Gap Interface.....	65
7.3.3	Interface ‘A _{L4} ’ – Activation Signal.....	67
7.4	Kernel Interface	68
7.4.1	Overview	68
7.4.2	Functional Requirements.....	68
7.4.3	Information Sent by EOLM to On-board Equipment.....	68
7.4.4	Timing Requirements.....	68
7.5	Interface ‘V_L’ – Test Interface.....	69
7.5.1	Overview	69
7.5.2	Receiver Performance Requirements	69
7.6	Power Supply of the On-board Equipment	74
7.7	Environmental Requirements	74
7.7.1	On-board Equipment	74
7.7.2	Environmental Conditions for the Antenna Unit Function.....	74
7.8	Installation Constraints for the Antenna Unit Function	74
7.9	Specific Electrical Requirements	74
7.10	Test Requirements.....	75
7.10.1	General	75
7.10.2	Test Signals	75
7.10.3	Test Tools	75
7.11	EMC Requirements	76
7.11.1	Emission	76
7.11.2	Immunity	76
ANNEX A	INFORMATIVE REFERENCES	78



ANNEX B	DIRECT SEQUENCE SPREAD SPECTRUM MODULATION (INFORMATIVE)	79
B.1	Multi Path Environment for Euroloop Subsystem	79
B.2	DSSS Principles	79
B.3	Basic Transmitter Functionality	79
B.4	Basic Receiver Functionality	80
B.5	Robustness against Interference	81
B.6	Processing Gain	83
B.7	Properties of Spreading Codes	83
B.8	Orthogonality	84
B.9	Even and Odd Cross Correlation	84
B.10	Receiver Performance	84
B.11	Methods for SSCode Evaluation	84
B.12	Distortions of the Euroloop Signal in the Air Gap	85
ANNEX C	INFLUENCE OF DEBRIS (INFORMATIVE)	86
C.1	Introduction	86
C.2	Considered Debris	86
C.3	Measurement Results	87
C.4	Conclusion	87
ANNEX D	GENERAL INSTALLATION RULES (INFORMATIVE)	88
ANNEX E	TELEGRAM TRANSMISSION TIME (INFORMATIVE)	89
ANNEX F	EUROLOOP SPREAD SPECTRUM CODES (NORMATIVE)	90

3 GENERAL

3.1 Foreword

The main body of this standard, and the relevant Annexes designated as “normative”, constitute the mandatory requirements for achieving air gap interoperability between any possible combination of Trackside and On-board Equipment. Annexes designated as “informative” either provide background information for the mandatory requirements or outline non-mandatory requirements and optional functionality.

This SUBSET-044 version 2.1 or higher includes the contents of the former SUBSETs-043, -045, and -050.

SUBSET-103 [N5] specifies the corresponding test methods, procedures and tools for verification of compliance with the mandatory requirements of SUBSET-044 (this document).

3.2 Normative References

To distinguish normative from informative references, the reference numbers of the normative ones start with an “N” (e.g. [N5]) while the informative ones (see Annex A) start with an “I”.

Documents in this sub-clause 3.2 contain provisions which, through reference in this text, constitute provisions of the present document.

- [N1] EN 50121-2: September 2000, Railway applications – Electromagnetic compatibility – Part 2: Emission of the whole railway system to the outside world.
- [N2] EN 50121-3-2: September 2000, Railway applications – Electromagnetic compatibility – Part 3-2: Rolling stock – Apparatus.
- [N3] EN 50121-4: September 2000, Railway applications – Electromagnetic compatibility – Part 4: Emission and immunity of the signalling and telecommunications apparatus.
- [N4] EN 60529: October 1991 + A1 February 2000, Degrees of protection provided by enclosures (IP-Code).
- [N5] UNISIG SUBSET-103: ERTMS/ETCS – Class 1, Test Specification for Euroloop.
- [N6] UNISIG SUBSET-036: ERTMS/ETCS – Class 1, FFFIS for Eurobalise.
- [N7] UNISIG SUBSET-026-2: ERTMS/ETCS – Class 1, System Requirements Specification Chapter 2, Basic System Description.
- [N8] UNISIG SUBSET-026-3: ERTMS/ETCS – Class 1: System Requirements Specification Chapter 3, Principles.
- [N9] UNISIG SUBSET-026-7: ERTMS/ETCS – Class 1: System Requirements Specification Chapter 7, ERTMS/ETCS Language.
- [N10] UNISIG SUBSET-026-8: ERTMS/ETCS – Class 1: System Requirements Specification Chapter 8, Messages.
- [N11] UNISIG SUBSET-085: ERTMS/ETCS – Class 1: Test Specification for Eurobalise FFFIS.
- [N12] UNISIG SUBSET-088-1 Part 2: ERTMS/ETCS – Class 1: ETCS Application Level 1 - Safety Analysis - Part 2 – Functional Analysis.



- [N13] UNISIG SUBSET-088 Part 3: ERTMS/ETCS – Class 1: ETCS Application Levels 1 & 2 – Safety Analysis; Part 3 – THR Apportionment.
- [N14] UNISIG SUBSET-091: ERTMS/ETCS – Class 1: Safety Requirements for the Technical Interoperability of ETCS in Levels 1 & 2.
- [N15] UNISIG SUBSET-040: ERTMS/ETCS – Class 1: Dimensioning and Engineering Rules.
- [N16] UNISIG SUBSET-041: ERTMS/ETCS – Class 1: Performance Requirements for Interoperability.
- [N17] UNISIG SUBSET-023: ERTMS/ETCS – Class 1: Glossary of Terms and Abbreviations.
- [N18] EN 50155, August 2001: Railway applications - Electronic equipment used on rolling stock.
- [N19] EN 50124-1 March 2001 + A1 October 2003: Railway applications - Insulation coordination, Basic requirements, Clearance and creepage distances for all electrical and electronic equipment.
- [N20] EN 50126, September 1999: Railway applications - The specification and demonstration of Reliability, Availability, Maintainability and Safety.
- [N21] EN 50128, March 2001: Railway applications - Communications signalling and processing systems, Software for railway control and protection system.
- [N22] EN 50129, February 2003: Railway applications - Communications, signalling and processing systems – Safety related electronic systems for signalling.
- [N23] EN 50122-1, June 1997: Railway applications - Fixed Installations, Protective provisions relating to electrical safety and earthing.
- [N24] EN 50125-1, September 1999: Railway applications – Environmental conditions for equipment – Part 1: Equipment on board rolling stock.
- [N25] EN 50125-3, January 2003: Railway applications – Environmental conditions for equipment – Part 3: Equipment for signalling and telecommunications.
- [N26] Draft EN 302 609, V1.1.1 (2007-12)¹: Electromagnetic compatibility and Radio spectrum Matters (ERM); Short Range Devices (SRD); Radio equipment for Euroloop railway systems; Harmonized EN covering essential requirements of article 3.2 of the R&TTE Directive.
- [N27] EN 50159-1: March 2001, Railway Applications – Communication, Signalling and Processing Systems – Part 1: Safety-Related Communication in Closed Transmission Systems.
- [N28] IEC 62153-4-3. Ed. 1: Surface transfer impedance – Triaxial method

¹ Draft EN 302 609, V1.1.1 was published for public enquiry 2007-12



3.3 Scope

This standard is part of the overall normative framework that constitutes the basis for the ERTMS/ETCS Control-Command and Signalling system.

This Norm is part of the overall set of normative background that constitutes the basis for the European Union Directive 96/48/EC on Trans-European High Speed Railway Network Interoperability, and for the relevant Technical Specification for Interoperability (TSI).

The TSI (Technical Specification for Interoperability) defines the concept of “Technical Interoperability” that applies to the “Constituents” of the Control-Command Sub-System.

As far as the Euroloop Transmission System is concerned, the Trackside and the On-board Equipment are interoperability constituents considered in this standard.

The Euroloop Subsystem (ELS) is a subsystem of the European Train Control System (ETCS), which itself is a subset of the European Rail Traffic Management System (ERTMS).

This document is the Form Fit Function Interface Specification (FFFIS) for the ELS. It specifies the mandatory requirements for the interfaces and functionalities to ensure

- the operation of the ELS within the ERTMS/ETCS environment,
- interoperability between the Trackside and On-board Equipment of the ELS over the air gap.

Meeting these requirements allows industrial manufacturers to develop and produce interoperable Euroloop On-board or Trackside Equipment.

4 ABBREVIATIONS AND DEFINITIONS

4.1 Introduction

Terms and abbreviations defined by reference [N17], although used in this document, may not be mentioned in the following lists. If listed, they are in agreement with [N17].

Further abbreviations and definitions commonly used for Euroloop are added and used in this document.

Further abbreviations and definitions explicitly used for Eurobalise, although used in this document, may not be mentioned in the following lists. If listed, they are in agreement with [N6].

4.2 Abbreviations

Abbreviation	Explanation
AC	Alternating Current
AU	Antenna Unit
BER	Bit Error Ratio
BPSK	Binary Phase Shift Keying
BTM	Balise Transmission Module or Eurobalise Transmission Module (see [N6])
CCK	Chip Clock
CDMA	Code Division Multiple Access
CENELEC	Comité Européen de Normalisation Electrotechnique (engl: European Committee for Electrotechnical Standardization)
CHS	Chip Sequence
cps	chips per second
CR	Chip Rate
CRNB	Co-channel Rejection for Narrow Band signals
CRWB	Co-channel Rejection for Wide Band signals
DBP	Deactivation Bit Pattern
DBPL	Differential Bi-Phase-Level
DBPSK	Differential Binary Phase Shift Keying
DC	Direct Current
DI	Distortion Immunity
DRP	Dynamic Receiver Performance
DS	Direct Sequence
DSSS	Direct Sequence Spread Spectrum
EC	European Community
ELC	Euroloop Leaky Cable (Leaky cable incl. termination)
ELS	Euroloop Subsystem

Abbreviation	Explanation
EMC	Electro Magnetic Compatibility
EN	European Standard
EOLM	End of Loop Marker
ERA	Euroloop Reference Antenna
ERT	ELC Reference Tool
ERTMS	European Rail Traffic Management System
ETCS	European Train Control System, which itself is a SUBSET of the ERTMS
EXNOR	Exclusive NOR Gate ($Q = (A \wedge B) \vee (A \wedge \bar{B})$)
FDMA	Frequency Division Multiple Access
FFFIS	Form Fit Function Interface Specification
FH	Frequency Hopping
FHDS	Frequency Hopping Direct Sequence
FRS	Functional Requirements Specification
FSK	Frequency Shift Keying
GSM-R	Global System for Mobile communication for Railways applications
ICNIRP	International Commission on Non-Ionizing Radiation Protection
IEC	International Electrotechnical Commission
IMI	Inter-Modulation Immunity
LD	Loop Decoder
LEU	Line side Electronic Unit
LOOMO	Loop Modem
Loop	Short for Euroloop
LR	Loop Receiver
LTM	Loop Transmission Module
MFP	Magnetic Field Probe
MTIE	Maximum Time Interval Error
MTTF	Mean Time To Failure
NID_LOOP	Euroloop Identification Number
OE	On-board Equipment (of ELS)
PG	Processing Gain
PLL	Phase Lock Loop
PN	Pseudo-Noise
PSK	Phase Shift Keying
Q_LOOPDIR	Qualifier to indicate the direction of the Loop Section
Q_SSCODE	Number of the Spread Spectrum Code

Abbreviation	Explanation
QoI	Quality of Installation
QoIM	Quality of Installation for Moving trains
QoIS	Quality of Installation for trains at Standstill
RAM	Reliability, Availability and Maintainability
RAMS	Reliability, Availability, Maintainability and Safety
RBC	Radio Block Centre
R-CDMA	Random CDMA
RF	Radio Frequency
RMS	Root Mean Square
RSRL	Reduced Size Reference Loop
SIR	Signal-to-Interference Ratio
SRS	System Requirements Specification
SSB	Single Side Band
SSCode	Spread Spectrum Code
TBC	To Be Confirmed
TBD	To Be Determined
TCFE	Tolerable Centre Frequency Error
TCRE	Tolerable Chip Rate Error
TDMA	Time Division Multiple Access
TE	Trackside Equipment (of ELS)
THR	Tolerable Hazard Rate
TSI	Technical Specification for Interoperability

Table 4-1: Abbreviations

4.3 Definitions

Term	Definition
Activation Signal	Signal compliant with the specification of Interface 'A4' in [N6] used to activate the LOOMO.
Air Gap	Space between Euroloop Leaky Cable (ELC) function and Antenna Unit (AU) function (see sub-clause 6.8).
Antenna Unit	Antenna preferably suited to commonly transmit and/or receive Eurobalise, Euroloop, and activation signals through the air gap.
Barker Code	A Barker code is a string of digits $a_i \in \{0, 1\}$ of length $l \geq 2$ such that $\left \sum_{i=1}^{l-k} (2a_i - 1)(2a_{i+k} - 1) \right \leq 1$ for all $1 \leq k < l$ (see sub-clause 6.3.4).
Corruption	Transmission of an erroneous telegram interpretable as correct.
Cross-Talk	Synonym for "insertion".
Deletion	The lack of reception along a whole Loop Section, and/or creation of unacceptable delay of data.
End of Loop Marker	An Eurobalise that is to announce the beginning or ending of an Euroloop by transmission of an End-of-Loop-Marker Packet to the On-board Equipment.
End of Loop Marker Packet	This is a set of information attributed to the Euroloop (see sub-clause 5.2.2).
Eurobalise functionality	This is the term used for all functions needed to transfer the End of Loop Marker (EOLM) packet from the Trackside to the On-board Equipment and to allow activation of the Euroloop (see sub-clause 5.2.2).
Euroloop functionality	Term used for the whole functionality to transmit Euroloop telegrams from the Trackside Equipment (see clause 6) to the On-board Equipment (see clause 7).
Euroloop telegram	This is a bit stream in a coded form containing a Loop message (see sub-clause 6.3.4 of this document and [N6]).
Frequency Band	Continuous range of frequencies extending between two frequency limits.
Immunity	The ability of a device, equipment or system to perform without degradation in the presence of an electromagnetic disturbance or interference.
In-fill Information	Data that is transmitted from track to train at locations other than at main signals. For example, it informs the train that the signal ahead has cleared.
Insertion	Erroneous reporting of a Loop telegram in a different track or from another loop in the same track, i.e., cross talk.
Interfering Signal	A signal that impairs the reception of a wanted signal.

Term	Definition
LTM Function	Sum of Loop Receiver (LR) Function and Loop Decoder (LD) Function.
Kernel	The core of the ERTMS/ETCS On-board Equipment.
Kernel Interface	This is a company specific On-board interface that links the LTM Function with the ERTMS / ETCS Kernel.
Lineside Electronic Unit (LEU)	A trackside electronic unit that interfaces the national trackside signalling / interlocking equipment with Eurobalise and Euroloop.
Loop	Track mounted device for the transmission of data between track-to-train.
Loop Message	The message to be transmitted by an Euroloop subsystem, defined in [N10]. It consists of a single Euroloop telegram.
Loop Modem (LOOMO)	The signal generating part of the Trackside Equipment (see also sub-clause 6.1.1, 6.3, and 6.7).
Loop Section	Range of x-positions of the centre of the Antenna Unit function between the input of the ELC and its termination, where, from the layout point of view, the Euroloop is expected to perform with a Quality of Installation (QoI) according to sub-clause 6.10.9.
Loop Signal	An up-link signal contained in the magnetic field of the air gap. It is generated by the Trackside Equipment and carries an Euroloop telegram (see also sub-clause 6.8.3).
On-board Equipment (OE)	Term used for the equipment installed in the engine that consists of the Antenna Unit (AU) function, the Loop Receiver (LR) function, and the Loop Decoder (LD) function.
Trackside Equipment (TE)	Term used for the equipment along trackside consisting of the data transmission equipment interconnecting the Lineside Electronic Unit (LEU) with the Loop Modem (LOOMO), the LOOMO, the jumper cable between the LOOMO and the Euroloop Leaky Cable (ELC), and the ELC that includes its termination.

Table 4-2: Definitions

5 EUROLOOP SUBSYSTEM

5.1 Architectural Layout

5.1.1 Euroloop within ERTMS/ETCS

The SUBSET-026-2 [N7] provides the basic description of the system proposed to satisfy the mandatory functional requirements of the overall Functional Requirements Specification (FRS) of ETCS.

In ETCS Level 0, line side optical signals or other means of signalling external to ERTMS/ETCS are used to give movement authorities to the driver. ETCS Level 0 uses no track to train transmission except (unlinked) Eurobalises to announce/command ETCS level transitions. Therefore, Eurobalises still have to be read.

In ETCS Level 1, the train control information is transmitted to the train using either a controlled or a fixed Eurobalise. In-fill information may be provided by the Eurobalise system, by the Euroloop, or by the radio in-fill system (see Figure 5-1).

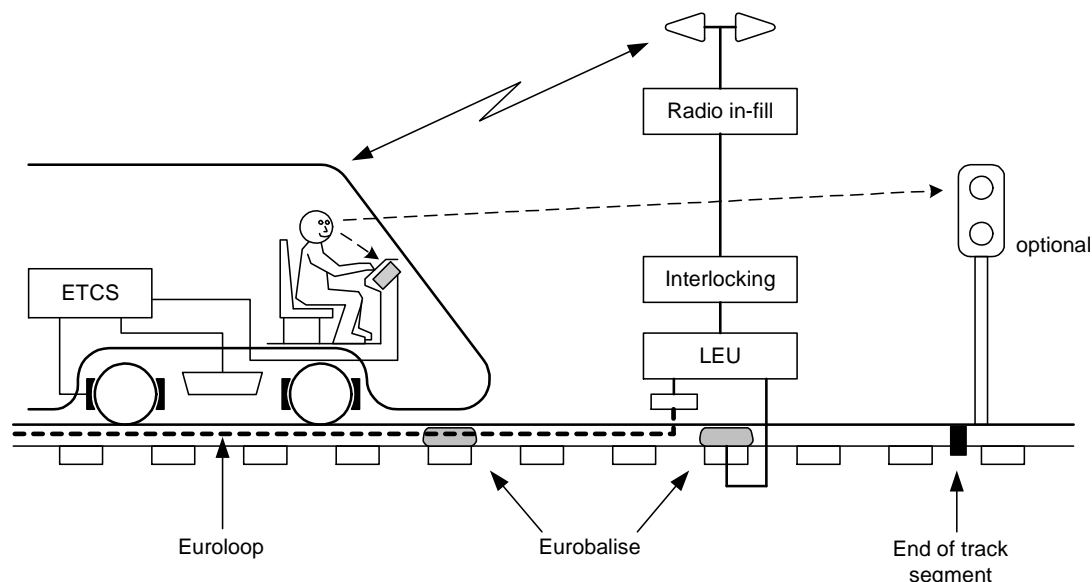

Figure 5-1: ERTMS/ETCS Level 1 with In-fill

The Euroloop Subsystem (ELS) provides signalling in-fill information in advance as regard to the next main signal in the train running direction as soon as they become available. This improves the availability of ETCS Level 1 train systems as it allows train operation without release speed. SUBSET-026-3 specifies the corresponding System Requirements Specifications (SRS) of the ELS.

Depending of the ETCS level, the trackside sub-system can be composed of

- Eurobalise,
- Lineside Electronic Unit (LEU),
- the radio communication network (GSM-R),
- the Radio Block Centre (RBC),
- Euroloop, and
- Radio in-fill unit.

ETCS Level 1 track-to-train communication is provided by either or a combination of the Eurobalise, the Radio in-fill or the Euroloop system.

The Eurobalise system represents a spot transmission communication system to transmit trackside information to the On-board system.

The Euroloop Subsystem is a semi-continuous, intermittent transmission system. It transmits in-fill information from the trackside infrastructure to a train (up-link) at standstill or movement along a section of the track (see also [N7], and [N8]. It uses a leaky cable as a trackside transmission antenna. The Euroloop system is composed of an On-board Equipment and one or several Trackside Equipments.

5.1.2 Interfaces Overview

Figure 5-2 identifies all interfaces of the ELS.

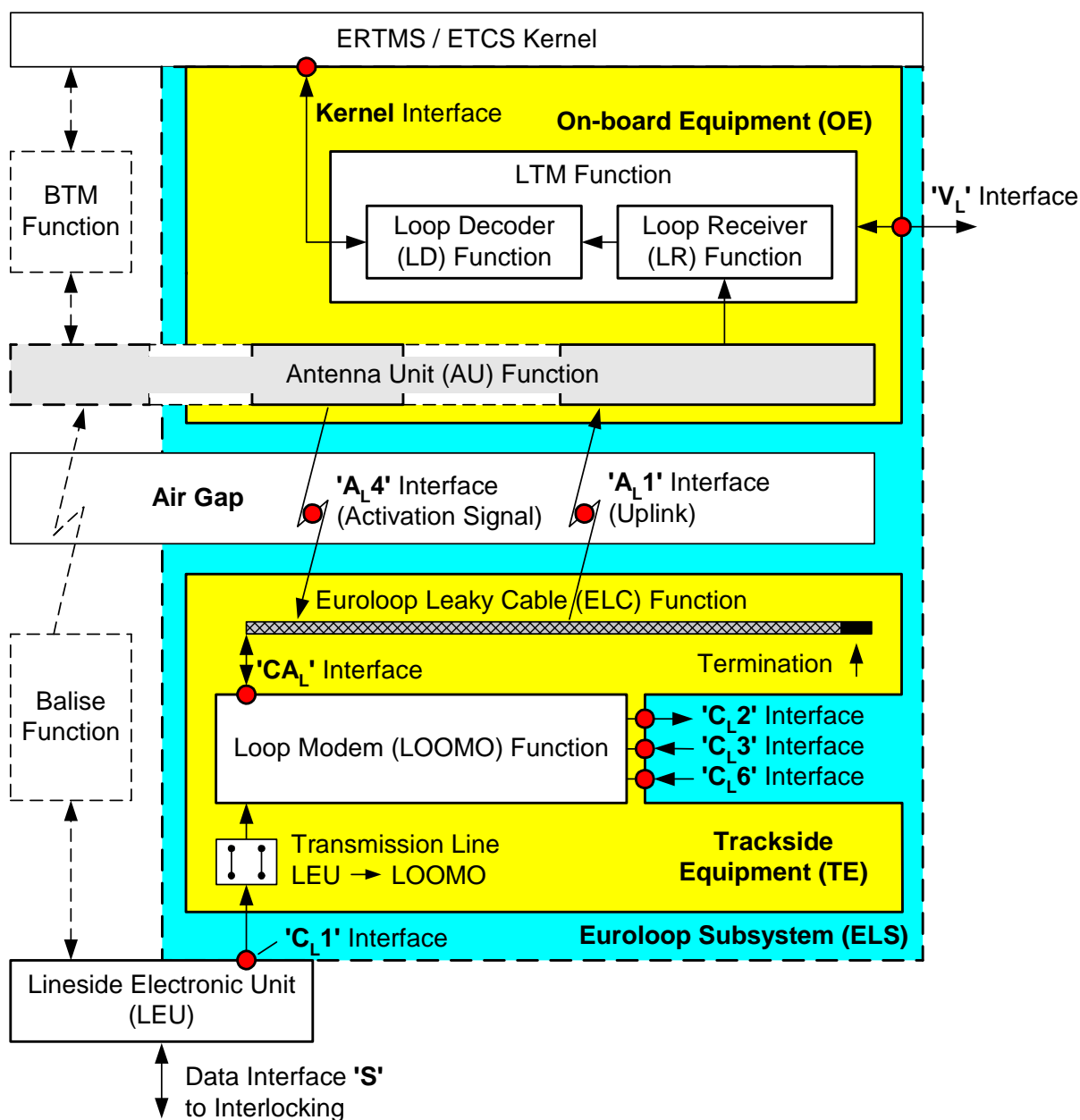



Figure 5-2: ELS Interfaces

It is desired but not mandatory to use the same Antenna Unit (AU) function for the Euroloop and Eurobalise functionality.

- Interface 'C_L1'** This interface is used to transmit Euroloop telegrams from the LEU to the LOOMO. It is located at the output of the LEU.
- Interface 'C_L2'** This is an optional interface that shall indicate the status of the LOOMO.
- Interface 'C_L3'** This interface may be used to activate the LOOMO by an external activation signal.
- Interface 'C_L6'** This interface is used to power the LOOMO from an external power source.
- Interface 'CA_L'** This interface is the trackside interface at the output of the LOOMO. It is used to verify the Euroloop signal's compliance with the corresponding requirements in this document at the output of the LOOMO.
- Interface 'A_L1'** This interface is used for transmitting up-link Euroloop telegrams from the Euroloop Leaky Cable (ELC) to the Antenna Unit function. Telegrams shall be sent to the air gap with the same data rate as they are received from Interface 'C_L1'.
- Interface 'A_L4'** This is the interface used to activate the LOOMO. The signal on this interface is subsequently called "activation signal". It is radiated by the Antenna Unit (AU) function into the air gap. The Eurobalise system uses this signal to tele-power Eurobalises (see [N6]).
- Interface 'V_L'** This interface is used to test and verify the On-board functionality. A company specific adapter may provide the specified interface.
- Kernel Interface** This company specific On-board interface links the LTM Function with the ERTMS / ETCS Kernel.

5.2 Functional Requirements

5.2.1 Extension of Eurobalise Functions

The ELS is a straightforward extension of the Eurobalise subsystem [N6]. While Eurobalise represents a spot transmission system, Euroloop performs the function of a semi-continuous transmission system allowing transmission of information from a section of the track to the train. A main and basic task for ELS is to transmit in-fill information according to [N8].

Location references for a train are provided by End of Loop Markers (EOLMs). It is not allowed to deduce any position information or any location reference from an ELS or from an Euroloop signal.

5.2.2 Identification and Activation of Trackside Equipment

5.2.2.1 Identification

Eurobalise functions do not depend on ELS but the ELS functions need some Eurobalise functionality as a prerequisite for the purposes detailed below.

Eurobalise functionality is required for all functions needed to transfer the EOLM packet from the trackside installation to the On-board function. The packets, variables, and qualifiers transmitted by the EOLM from the Trackside installation to the On-board Equipment attributed to a particular Euroloop are defined in SUBSET-026-7 [N9].

5.2.2.2 Transfer of Spreading Code Number to Loop Receiver

After transfer of the received SSCode Number (the Q_SSCODE) by the ERTMS / ETCS Kernel to the LTM Function Unit of the On-board Equipment, the Loop Receiver (LR) shall be enabled to receive Loop messages matching the spread spectrum signal with the particular SSCode of the addressed Euroloop.

5.2.2.3 Modes of Operation

LOOMO's modes of operation and the switching among them are specified in sub-clause 6.2.3 and 6.2.4.

5.2.3 Coupling and Modulation

The transmission of data between the Trackside Equipment and the On-board Equipment of the ELS shall be performed by using a combination of the two following methods:

- **Magnetic coupling** in the air gap. The ELS shall generate a magnetic RF field that shall be picked up by the Antenna Unit function. The magnetic field shall be generated by an RF signal injected into an Euroloop Leaky Cable. The z-component of this field shall induce a voltage in a receiving loop antenna contained in the Antenna Unit function (see Figure 5-3 for definition of geometrical references).
- **Direct Sequence Spread Spectrum (DSSS) modulation** (see Annex B) of the RF carrier signal. Use of different Spread Spectrum Codes (SSCodes) for different Trackside Equipment shall allow selective reception of the transmitted data by an On-board Equipment. Individual transmission channels are identified by their SSCode Numbers (Q_SSCODE) and are therefore individually accessible (so-called Code Division Multiple Access (CDMA)). One of the 15 SSCodes with Q_SSCODE Number 0 through 14 of length $N_c = 472$ according to Table F- 1 of Annex F shall be assigned to each Euroloop Trackside Equipment. The additional SSCode with Q_SSCODE fifteen (15) shall be used *exclusively* for testing purposes and it shall not be transmitted by the EOLM to the ERTMS/ETCS Kernel.

5.2.4 Multiple Trackside Equipment or On-board Equipment in Operation

A single Antenna Unit function may activate more than one Trackside Equipment at the same time.

The use of CDMA allows for discrimination between superimposing Euroloop signals originating from adjacent tracks.

More than one Antenna Unit function can be positioned within the Loop section. This may happen if more than one train is positioned within this section or if more than one On-board Equipment is installed on a single train. This may lead to situations where more than one On-board Equipment may receive the same Loop message of a single Trackside Equipment at the same time.

5.2.5 Coding Requirements

5.2.5.1 Telegram Coding

The structure and the protection of the Euroloop telegrams generated by the LEU shall be the same as for Eurobalise telegrams as defined in the sub-clause entitled “Coding Requirements” of [N6], and the Eurobalise Coding Strategy shall apply.

5.2.5.2 Error Detection

The error detection shall be according to the sub-clause entitled “Coding Requirements” in the SUBSET-036 [N6]

5.2.5.3 Transmission of Messages on Application Level

The general format shall be according to the sub-clause entitled “Coding Requirements” in the SUBSET-036 [N6].

5.2.6 Reliable Data Transmission

Sufficient protection of the data against thermal noise, interference and signal distortion in the air gap shall be achieved by data protection on a higher protocol level as defined in sub-clause 5.2.5.1.

Reliable prevention of insertion/cross talk (in case of a failure of the CDMA selection process) is provided on a higher system level (by the Kernel, see sub-clause 7.4) using the Loop Identification Number (NID_LOOP, see also SUBSET-026-7 [N9]).

5.2.7 Telegram Switching

A telegram is repeated “forever”, i.e., for the whole duration of a train passage along a Loop section. If the transmitter, i.e. the LEU, switches to a new telegram, a string of all zeros or a string all ones shall be inserted between the last transmitted bit of the old telegram and the first transmitted bit of the new telegram (the “last” and “first” transmitted bit can be any bit in the telegram and need not be b_0 and b_{n-1} , respectively, see the sub-clause entitled “Telegram Switching” of SUBSET-036 [N6]).

The length of this inserted string shall be between 75 and 128 bits (see also [N6]).



5.3 Performance Requirements

5.3.1 Train Speed

The ELS shall be able to transmit data between the Trackside and On-board Equipment for trains with speeds up to $v_T = 350$ km/h.

5.3.2 System Response Times

The system response times associated with transmission of Euroloop signal from the Trackside to the On-board Equipment allows to fulfil the Performance Requirements for Interoperability stated in SUBSET-041 [N16] taking into account the need on response times of further system parts of the ERTMS/ETCS (see also sub-clause 6.8.2.3, and 7.4.4).

5.4 RAMS Requirements

5.4.1 General

The Reliability, Availability, Maintainability and Safety (RAMS) requirements constitute global characteristics of the long-term operation of the constituents involved in the Transmission System. They are achieved by the application of established engineering concepts, methods, tools, and techniques throughout the lifecycle of the system. The RAMS requirements are expressed in qualitative and quantitative terms that ensure both availability and safety.

A detailed RAMS Program shall be agreed for a given constituent under consideration, and shall be implemented throughout the lifecycle of that system. The RAMS Program (RAM Program and Safety Plan) shall address issues related to RAMS management, reliability, availability, maintainability, and safety, in accordance with the applicable definitions of EN 50126 [N20].

Annex B of EN 50126 [N20] gives guidelines, methods, and tools suggested for the preparation of a generic RAMS Program.

5.4.2 Top Level Functionality

Table 5-1 lists the top level functionality of the constituents of the Euroloop Transmission System in terms of basic functions with the related top level hazards.

Table 5-1: List of Relevant Top Level Functionality and its Related Top-Level Hazards

No.	Function Description	Related Hazards (see also sub-clause 5.4.6.2.2)
F _L 1	Transmit protected data from trackside devices to the intended train devices	H4, H9

5.4.3 Reliability

5.4.3.1 General Requirements

The reliability of the constituents of the Transmission System defines the probability to perform the basic functions defined in Table 5-1 in sub-clause 5.4.2 under given conditions for a given time interval.

For a given application case, the overall RAM Program and the related quantitative and qualitative targets shall be agreed. Its implementation shall cover the entire lifecycle of the system.

The reliability analyses shall consider the following issues:

- Functional analysis and failure definition for the system under consideration.
- Prediction of reliability.
- Fault Tree Analysis or Failure Modes Effects Analysis.
- Apportionment of reliability targets (MTTF) for the various components of the system.
- The overall RAM program.
- Reliability Assurance Plan for each hardware assembly.
- Quality Assurance Plan for software components.
- Reliability Test Plan.

- Collection of operational data for the assessment of the achieved reliability.

The MTTF (Mean Time To Failure) for a given constituent of the Transmission System might fluctuate with the time. The reliability targets concern the mean MTTF value over the operational lifetime. In general, the minimum operational lifetime shall be 20 years.

The ELS shall comply with the reliability requirements stated in EN 50126 [N20].

5.4.3.2 Reliability Cross Talk

Reliability cross talk is defined as an interfering effect on the transmission of data such that transmission is corrupted but not interpretable as other valid information, or unattainable, due to e.g. a non-intended Euroloop transmitter.

The constituents of the Transmission System shall operate so as to ensure that reliability cross-talk from, and to, adjacent tracks does not adversely affect the overall reliability. The trackside installation rule provided in sub-clause 6.10.5 states the limit for the Signal-to-Interference Ratio (SIR) of wanted to unwanted Euroloop signals power on Loop sections of type M and S.

5.4.4 Availability

5.4.4.1 General Requirements

The availability of the constituents of the Transmission System defines the ability to perform the basic functions defined in Table 5-1 in sub-clause 5.4.2 under given conditions at a given instant in time, or over a given time interval, assuming that the required external resources are provided.

The availability analysis for the system shall consider:

- The intrinsic availability of the components.
- The functional redundancy of critical components.
- The distinctions of the possible failures according to the basic categories of immobilising failure, service failure, and minor failure (according to definitions of EN 50126 [N20]).
- The overall RAM Program.
- The way of collecting operational data for the assessment of the achieved availability.

The ELS shall comply with the availability requirements stated in EN 50126 [N20].

Note: The ELS is a radio based transmission system and therefore a missing transmission may be a normal operational case. Such a situation is admitted and reflected by the specified Quality of Installation (QoI) figures given in sub-clause 6.10.9.

5.4.4.2 Impaired or Disabled Transmission

The transmission might be temporarily impaired or disabled due to interference, cross-talk, propagation effects or defective equipment. In this case the reaction of the ERTMS/ETCS Kernel is the same as without installed Loop Transmission Module (LTM). Therefore, the ELS is only used for in-fill purposes as detailed in sub-clause 5.1.1 and specified in SUBSET-026-3 [N8].

The availability A_{ELS} of the Euroloop system decomposes into

- the availability A_{TE} of the Trackside Equipment (TE),
- the availability A_{OE} of the On-board Equipment (OE), and
- the availability A_{RC} of the Radio Channel (RC).

As these three availabilities are statistically independent of each other, A_{ELS} amounts to

$$A_{ELS} = A_{TE} \times A_{OE} \times A_{RC}.$$

The availability of the radio channel for independent and identically distributed data symbol errors is given by

$$A_{RC} = 1 - (1 - (1 - BER)^N)^M,$$

where N is the length of the Euroloop telegram (see sub-clause 6.3.3), and M denotes the number of available telegrams to the On-board Equipment.

Table 5-2 shows the availability A_{RC} of the Euroloop radio channel as a function of the number M of available Euroloop telegrams along the Loop section provided the BER amounts to $BER \leq 2 \times 10^{-4}$ and N is 1100 (long Euroloop telegrams with 1023 data symbols plus 77 extra data symbols as required for the decoding of the Euroloop telegram, see sub-clause on “coding requirements” in SUBSET-36 and sub-clause 6.3.3). This applies within the entire specified range of environmental conditions and train speeds.

Table 5-2: Availability and Un-Availability of the Euroloop Radio Channel

Number M of Available Euroloop Telegrams	Availability of the Euroloop Radio Channel A_{RC}
1	$\geq 80.2\%$
2	$\geq 96.0\%$
3	$\geq 99.2\%$
4	$\geq 99.84\%$
5	$\geq 99.96\%$

According to EN 50126 [N20] the availability A_{TE} , and A_{OE} of Trackside, and On-board Equipment, respectively, is

$$A_{TE} = MUT_{TE} / (MUT_{TE} + MDT_{TE}), \text{ and}$$

$$A_{OE} = MUT_{OE} / (MUT_{OE} + MDT_{OE}),$$

where MUT_{TE} , and MUT_{OE} is the Mean Up Time and MDT_{TE} , and MDT_{OE} the Mean Down Time of the Trackside, and On-board Equipment, respectively.

The MUT shall be defined by the manufacturer of the equipment.

The MDT is dependent on the application (railway) and is therefore out of the scope of this specification.

5.4.5 Maintainability

The maintainability of the constituents of the Transmission System defines the probability that an active maintenance action to any component of the system can be successfully carried out within a given time interval under defined conditions and procedures.

The ELS shall comply with the maintainability requirements stated in EN 50126 [N20].

5.4.6 Safety

5.4.6.1 General

The figures for the safety goals of the ETCS On-board and trackside constituents, and in particular of the Loop components are deduced from the safety-analysis of SUBSET-088-3, which is in accordance with the requirements of the EN 50126 [N20].

All work pertaining to safety shall comply with the standards SUBSET-088 [N12] and [N13], SUBSET-091 [N14], EN 50126 [N20], EN 50128 [N21], EN 50129 [N22], and EN 50159-1 [N27]).

The *physical loop channel* is defined as the hard- and software part of the ELS, and is located between the output of the LEU (Interface 'C_L1') and the input of the Kernel Interface. The *trusted parts* of this physical loop channel are defined in SUBSET-088-3 [N13] and SUBSET-091 [N14].

5.4.6.2 Safety Targets of the Euroloop Subsystem

5.4.6.2.1 Overview

The safety targets of the Euroloop are based on a safety analysis and can be deduced from the requirements of the ERTMS/ETCS SUBSET-091 [N14]. Derivations of the safety targets of the Euroloop are documented in ERTMS / ETCS SUBSET-088-3 [N13].

5.4.6.2.2 Transmission Hazards

The potential transmission hazards are (see SUBSET-088-3 [N13])

Corruption (TRANS-LOOP-1):	Transmission of an erroneous telegram/telegrams interpretable as correct.
Deletion:	The missing of reception along a whole Loop Section.
Insertion (TRANS-LOOP-3):	Erroneous reporting of a Loop in a different track, or at a different position along the same track, with reception of valid telegram/telegrams, i.e. cross talk .

Specifically, regarding the **corruption** hazard H4, it includes the concept of a non-trusted channel in accordance with EN 50159-1 [N27]. The boundaries of the non-trusted channel are supplier specific, and the following concepts apply:

- Each supplier has to define the boundaries between the non-trusted channel and the trusted part of the channel based on the definitions of all possible failures as defined in EN 50159-1 [N27].

- Provided that the On-board part is equal to or better than the “Basic Receiver” defined in the sub-clause entitled “Basic Receiver Operation” of SUBSET-036 [N6], and performs all the consistency checks on the received data that are required by the System Requirements Specification (SRS, see UNISIG SUBSET-026), it can be assumed that the coding requirements, and the defined Basic Receiver (see SUBSET-036 [N6]), protects against all possible failures leading to corruption within the non-trusted channel (as defined by EN 50159-1 [N27]).
- The trusted part of the channel will need a demonstration that a minimum Tolerable Hazard Rate is fulfilled (see UNISIG SUBSET-088, Part 3, TRANS 1, [N13]).

For a formal approval of the non-trusted channel, a safety demonstration is required to the level of 10^{-11} failures/hour considering the mission profile defined in higher-level system documentation (see UNISIG SUBSET-088, Part 3 [N13] and SUBSET-091 [N14]).

In case of the Loop, **deletion** is not considered as an issue since the Loop is supposed to provide an in-fill function which, under certain conditions, will release the On-board Equipment from a braking intervention (see also sub-clause 5.4.4.2). According to part 2 of SUBSET-088-1 [N12], the Loop is used to transmit data that are less restrictive, i.e. as specified in SUBSET-026-3 [N8]. Additionally, there are no safety requirements involved on potential downgrading a signal aspect. Therefore, deletion of a Loop messages will result in a failure to the safe side and is therefore not considered to be a hazard (see sub-clause 4.1.16 of Annex A of SUBSET-088-3 [N13]).

To get an Euroloop **insertion** event, first an Eurobalise message cross-talk must occur conveying EOLM information. Since this barrier by itself is strong enough to fulfil the safety targets, there are no additional requirements on Euroloop with respect to insertion/cross-talk. Thus insertion/cross talk with respect to the loop is not considered to be a hazard. See also sub-clause 5.4.6.3.1.4.

NOTE: TRANS-LOOP-1 denotes the hazard associated with **corruption**.
 TRANS-LOOP-3 denotes the hazard associated with **insertion/cross talk**.
 The terms “**insertion**” and “**cross-talk**” are synonymously used.

5.4.6.2.3 Apportionment of ETCS Core Hazards to ELS Constituents

Table 5-3: Safety Hazards Associated with Corruption (TRANS-LOOP-1) with Indication of Target failures per hour [f/h]

Safety Hazards	Corruption (TRANS-LOOP-1): Incorrect loop message received by the On-board Kernel functions	Target [f/h]
	On-board Function	
LTM-H4	Transmission of erroneous telegram/telegrams, interpretable as correct, due to failure within the On-board LTM function.	$< 10^{-11}$
	Trackside Function	
LO-H4	Transmission of erroneous telegram/telegrams interpretable as correct, due to failure within a Loop.	$< 10^{-11}$

The related function is found in Table 5-1, and the origin of failure is amongst

- Loop cable,



- On-board Transmission Equipment,
- LEU,
- Air Gap,
- Interface 'C_L1', and
- Programming.

5.4.6.3 Basic Principle of the Safety Concept

5.4.6.3.1 Safety of Data Transmission

5.4.6.3.1.1 General Requirements

An ELS shall only be implemented as supplement to an Eurobalise Transmission System and an ERTMS/ETCS Kernel function (see sub-clause 5.2.2).

No single independent failure shall result in a hazard classified as 'catastrophic' or 'critical' in terms of hazard severity. The hazard severity levels are provided in EN 50126 [N20]. Secondary or dependent failures that occur as a result of an initial failure shall be considered in combination with that initial failure.

A safety case shall demonstrate the fulfilment of the safety targets as detailed in sub-clause 5.4.6.2 and 5.4.6.3.2.2.

5.4.6.3.1.2 Ensuring Integrity of Euroloop Telegrams

Any design of the Trackside and On-board Equipment is acceptable provided that the safety targets are met. These safety targets require that there shall be no transmission of correctly coded telegrams from the Trackside to the On-board Equipment with wrong information content at any time instant. One possibility to avoid this is that the data transmission between Interface 'C_L1' and the ERTMS/ETCS Kernel is fully bit transparent. In this case, it is not possible that a single symbol or multiple symbols are inserted, deleted or otherwise rearranged within the ETCS Telegrams on the whole ELS transmission path between the Interface 'C_L1' and the output of the Loop Receiver function.

5.4.6.3.1.3 Impaired Transmission

Impaired transmission means, that one or more data bits of an Euroloop telegram are corrupted. In this case, an Euroloop telegram shall not be detected as correct. The basic receiver operation of the Loop Decoder (LD) function shall ensure that only correct Euroloop telegrams are accepted and fed to the ERTMS/ETCS Kernel. This requirement is fulfilled by the coding of the Euroloop telegrams (see also sub-clause 7.2.2).

5.4.6.3.1.4 Insertion/Cross Talk

The use of SSCode numbers (Q_SSCODE) and their associated SSCodes is not safety relevant for the Euroloop Transmission system since the loop identity is matched with the EOLM information by the ERTMS/ETCS Kernel.

Safety cross talk is defined as the acceptance of a 'valid' message by an unintended receiver, i.e., an erroneous reporting of a Loop telegram in a different track or possibly at another location of the same track (also called **insertion/cross talk**). The Euroloop functionality shall ensure that safety cross talk from and to adjacent tracks and within the same track is not possible. This shall be included in the safety case.

The safety cross talk prevention is realised within the ERTMS/ETCS Kernel by comparing the Loop Identification Number (NID_LOOP, see SUBSET-026-7 [N9]) contained within the received loop message with the corresponding Loop Identification Number contained in the End of Loop Marker (EOLM) Packet that announced the Loop to the On-board Equipment (see also sub-clause 5.2.2). If this comparison reveals unequal Loop Identification Numbers, the ERTMS/ETCS Kernel rejects the corresponding Euroloop telegram.



Reliable prevention of safety cross talk is assumed to be provided on a system level of the Euroloop functionality: Having “addressed” the expected Euroloop by communicating its assigned SSSCode Number (known from the EOLM Packet) to the Loop Receiver, the Kernel expects a Loop message tagged by a Loop Identification Number (NID_LOOP) as assigned to this specimen of Euroloop by the same EOLM Packet (see also sub-clause 5.2.2).

A Loop message consists of a single telegram as defined in [N10].

In the case of the Loop, a loop message is required not to be accepted by the On-board Equipment unless a matching End of Loop Marker (EOLM) Balise as part of a linked chain is encountered first and duly accepted by the On-board Equipment.

5.4.6.3.2 Engineering

5.4.6.3.2.1 Assignment of Q_SSCODE

A Q_SSCODE specified in Table F- 1 of Annex F shall be assigned to each Euroloop Trackside Equipment. This Q_SSCODE specifies the coding of the Euroloop telegrams within the Euroloop Trackside Equipment.

5.4.6.3.2.2 Preparation of Euroloop Telegrams

The preparation of the Euroloop telegram data within the LEU is safety related. Therefore,

- the data preparation and
- the system deployment

shall comply with SUBSET-091 [N14].

5.4.6.3.2.3 Euroloop Engineering Process Requirement

The safety of the engineering process shall be such that the safety level of the overall system is not compromised.

5.5 Geometrical Reference

5.5.1 Coordinate System

The three reference axes related to the rails are defined as follows:

- A reference axis in parallel with the rails (the x-axis). The origin of the x-axis shall coincide with the input of the ELC.
- A reference axis at right angles across the rails, and which is level with the top of rails (the y-axis). The origin of the y-axis shall coincide with the middle of the track.
- A reference axis directed upwards, at right angles to the rail plane (the z-axis). Its origin is defined by the height of the top of rail.

Figure 5-3 illustrates the coordinate system used.

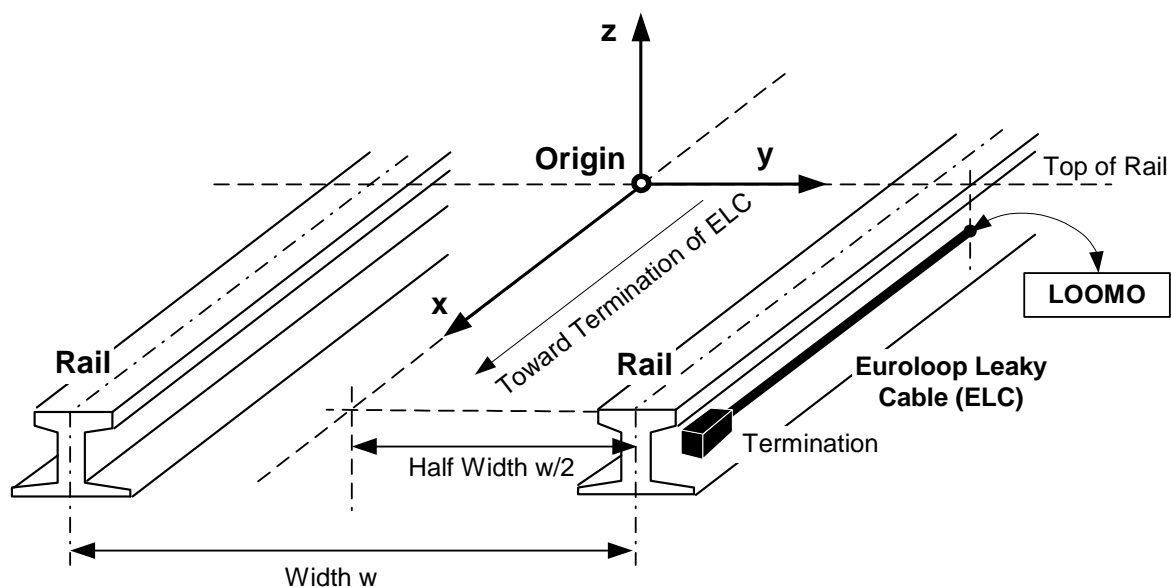

Figure 5-3: Coordinate System

5.5.2 Reference Position

The term “reference position” is defined as the geometrical location of all points along the Loop section with the coordinates $y = 0$ mm and $z = 300$ mm.

6 TRACKSIDE EUROLOOP SUBSYSTEM

6.1 Architectural Layout

6.1.1 Trackside Equipment

The modules of the Trackside Equipment are shown in Figure 6-1. It shall consist of

- the data transmission equipment interconnecting the LEU with the LOOMO,
- the LOOMO,
- the jumper cable between the LOOMO and the Euroloop Leaky Cable, and
- the Euroloop Leaky Cable that includes its termination.

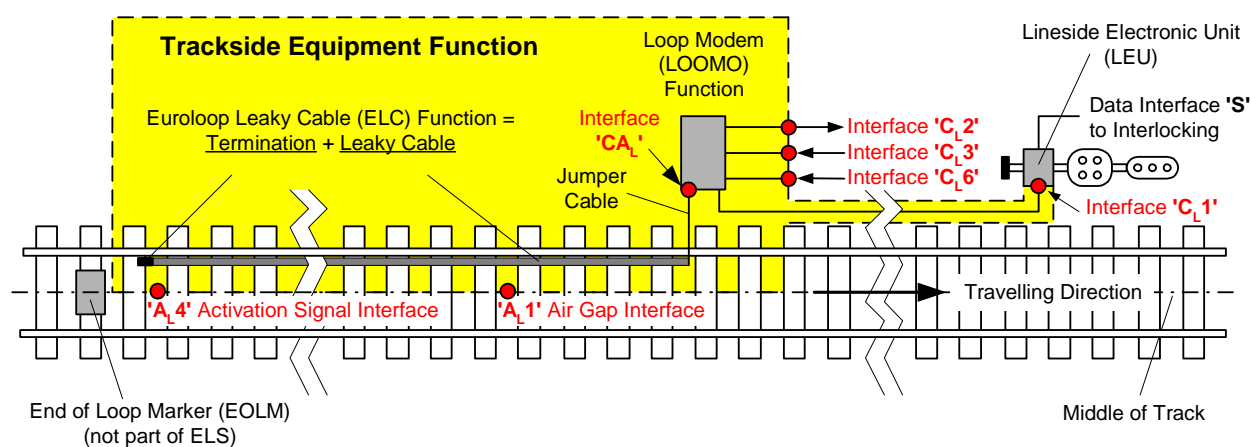

Figure 6-1: Trackside Equipment of Euroloop Subsystem (unidirectional installation)

An End of Loop Marker (EOLM) is by definition an Eurobalise to mark the beginning or the end of a Loop (see also SUBSET-026).

6.1.2 Sub-Sections

For the definition of the Quality of Installation (QoI) two types sub-sections are distinguished:

- Type M sub-sections denote range of x-positions of the centre of the Antenna Unit function, where, from the layout point of view, the Euroloop is expected to perform with a Quality of Installation for moving trains (QoIM) according to sub-clause 6.10.9.
- Type S sub-sections denote range of x-positions of the centre of the Antenna Unit function, where, from the layout point of view, the Euroloop is expected to perform with a Quality of Installation for trains at Standstill (QoIS) according to sub-clause 6.10.9.

A Loop section is made up of any combination of Type M or Type S sub-sections. For the definition of QoI see sub-clause 6.10.9.

6.1.3 Arrangements

From the constructive and functional point of view, the subsequent four (4) arrangements of ELS trackside installations should be possible.

- A Euroloop is called a *Single Euroloop* if it consists of a single or cascaded Trackside Equipment with the same SSSCode and common EOLM. Figure 6-2 shows a possible realisation of a single Euroloop arrangement.

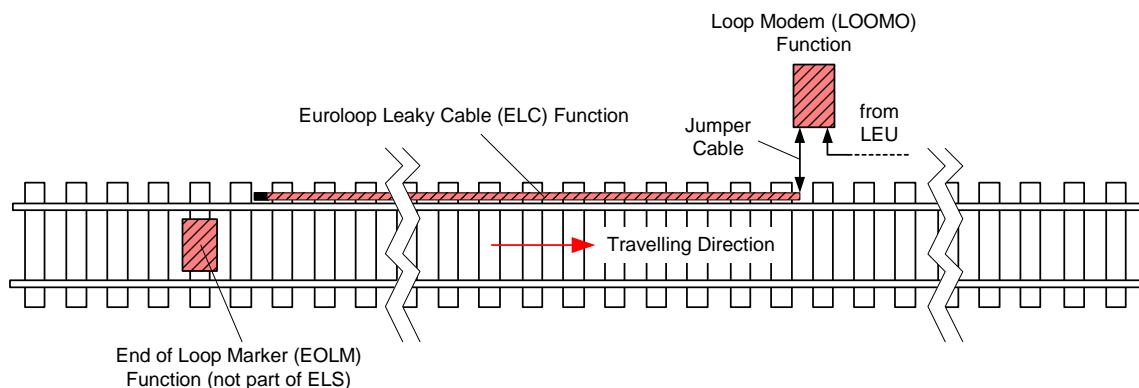

Figure 6-2: Possible Realisation of a Single Euroloop Arrangement

- A *Double Euroloop* is an arrangement of two (2) Euroloops assigned to a single track with Loop sections at partly common x-positions, but with individually assigned different EOLMs and SSCodes. Such an arrangement may be required along a single-track, where a transmission of different Loop messages is required depending on the moving direction of the train. It should be possible that both Euroloops are simultaneously active and transmission of respective Loop messages is performed simultaneously. Figure 6-3 shows a possible realisation of a double Euroloop arrangement. Specific installation requirements for this arrangement are defined in sub-clause 6.10.5.

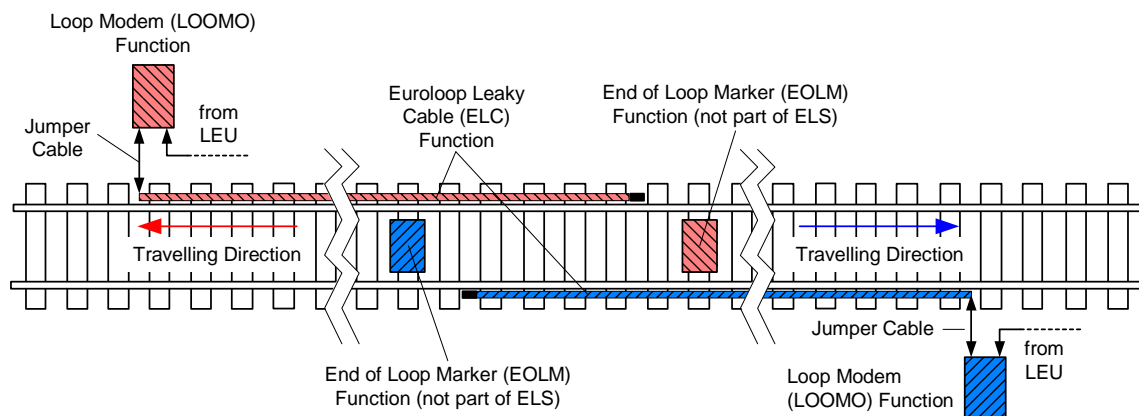

Figure 6-3: Possible Realisation of a Double Euroloop Arrangement

- In *Parallel Euroloops* arrangements, it is possible to use Single Euroloops with different EOLMs in neighbouring tracks. Figure 6-4 shows a possible realisation of a parallel Euroloop arrangement.

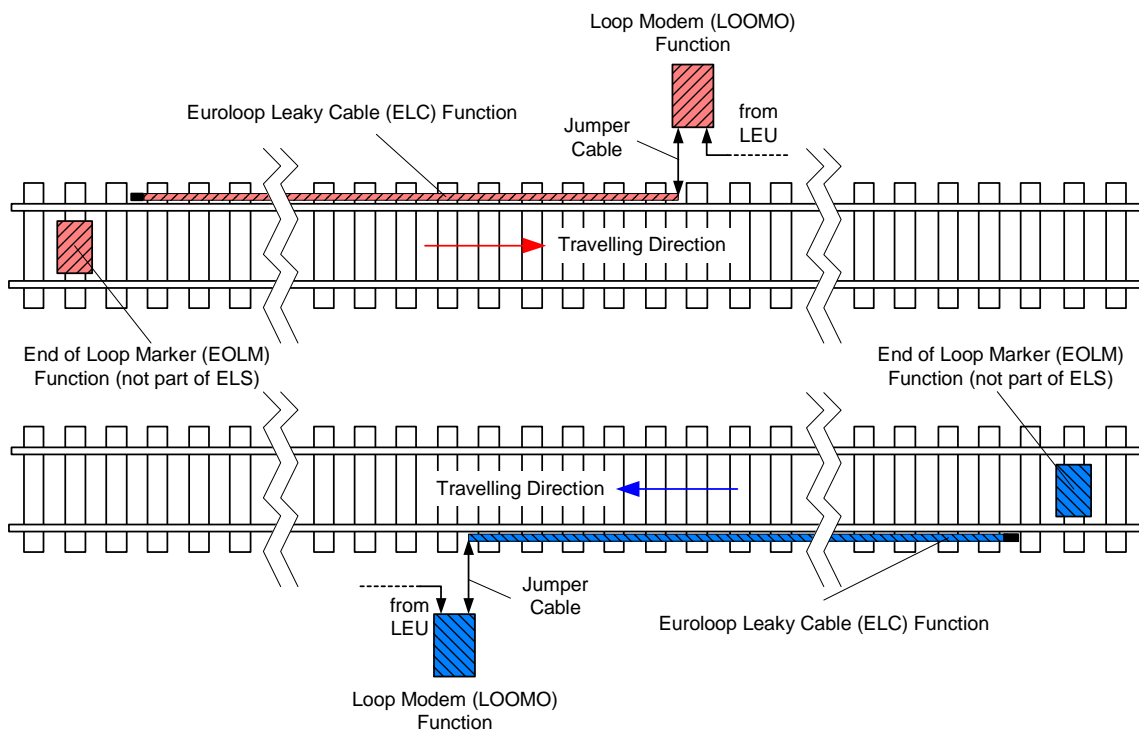

Figure 6-4: Possible Realisation of a Parallel Euroloop Arrangement

6.2 Functional Requirements

6.2.1 End of Loop Marker (EOLM)

When receiving the EOLM packet, the On-board Equipment knows that it is entering / leaving a track equipped with a Loop. In unidirectional application it is possible to have an EOLM only at the entry side of a Loop (see chapter 3 of SUBSET-026 [N8]). For other arrangements of the loop(s), more than one EOLM might be required.

The End of Loop Marker (EOLM) is used to transfer particular information such as the Identification Number (NID_LOOP), the Spread Spectrum Code Number (Q_SSCODE), and the Loop direction indication (Q_LOOPDIR) from the trackside installation to the On-board Equipment. For details on the subject see sub-clause 5.2.2.1 of this documents, chapter 7 [N9] and chapter 8 [N10] of SUBSET-026.

6.2.2 Assignment of Spreading Code

The SSCode assigned to the transmission of each Euroloop shall be settable for each LOOMO.

6.2.3 LOOMO's Modes of Operation

The LOOMO shall be switchable between two (2) operating modes known as "active" (transmitting) and "stand-by" (non-transmitting) mode as introduced in sub-clause 5.2.2.3. The transition between these two modes is specified in sub-clause 6.2.4.

6.2.4 Activation and Deactivation of LOOMO

The LOOMO switches between active (transmitting) and stand-by (non-transmitting) mode by the following events:

1. The signal on Interface 'C_{L1}' crosses a limit regarding its quality (see also sub-clause 6.3).
2. The logical state of the signal on Interface 'C_{L3}' changes (see also sub-clause 6.5).
3. The presence of the Deactivation Bit Pattern (DBP) on Interface 'C_{L1}' changes (see also sub-clause 6.2.5).
4. The presence of the activation signal on Interface 'A_{L4}' changes (see also sub-clause 6.8.2).

The precedence among the different activation and deactivation methods listed above causing a transition of the LOOMO between active and stand-by mode shall comply with the specifications given in Table 6-1.

Table 6-1: Order Among the Activation Methods of the LOOMO

Nr.	Signal on Interface 'C _{L1} ' Not Present with Sufficient Quality	Activation by Interface 'C _{L3} '	Detection of "Deactivation Bit Pattern" (DBP) on Interface 'C _{L1} '	Detection of Activation Signal on Interface 'A _{L4} '	LOOMO in Active (Transmitting) Mode
	'1' = Deactivation	'1' = Activation	'1' = Deactivation	'1' = Activation	'1' = Transmitting
1	'1'	'X'	'X'	'X'	'0'
2	'0'	'1'	'X' ('0')	'X'	'1' (Telegram)
	'0'	'1'	'X' ('1')	'X'	'1' (DBP transm.)
3	'0'	'0'	'0'	'0'	'0'
4	'0'	'0'	'0'	'1'	'1'
5	'0'	'0'	'1'	'X'	'0'

The minimum deactivation duration shall equal the duration required for the transmission of 255 data symbols on Interface 'C_{L1}' irrespective of the cause or method used for deactivation.

6.2.5 Deactivation Bit Pattern

If the LOOMO is in the active mode caused by the Activation Signal on Interface 'A_{L4}', it shall change to the stand-by mode upon receiving a sequence of more than 255 data symbols of logical value one (1) from Interface 'C_{L1}' (row 5 of Table 6-1).

The deactivation of the LOOMO shall be disabled on the first logical zero (0) value on Interface 'C_{L1}'. Hence for an uninterrupted deactivation the "Deactivation Bit Pattern" (DBP) shall be repeated continuously by the LEU.

6.3 Interface 'C_L1' - Up-link Data from LEU to LOOMO

6.3.1 Overview

The Interface 'C_L1' is located at the output of the Lineside Electronic Unit (LEU) as shown in Figure 6-5. The selected type of transmission line between LEU and Loop Modem (LOOMO) as well as the line receiver and line decoder corresponding to the selected type of transmission line shall be a part of the ELS. The type of the transmission line determines the possible distances between the LEU and the LOOMO. This guarantees correct transmission of the Euroloop telegrams from the LEU to the LOOMO.

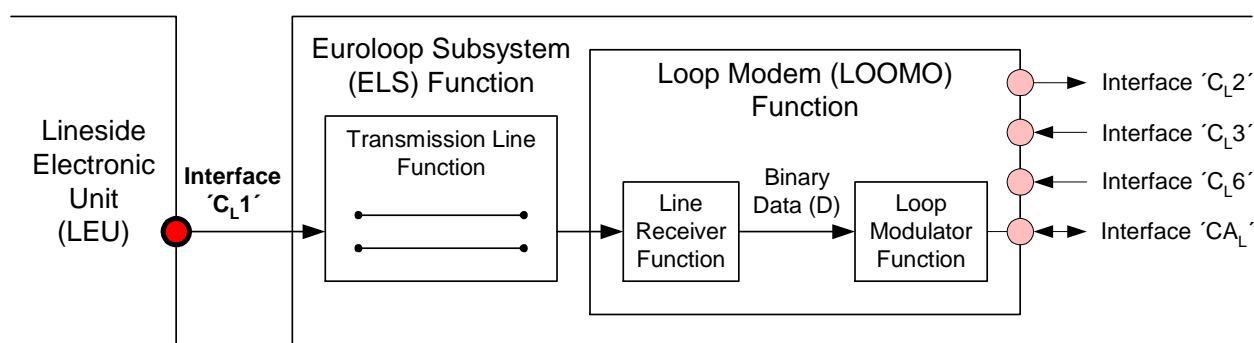

Figure 6-5: Data Transmission between LEU and LOOMO

The telegram structure of Interface 'C_L1' of the LEU is related to the Interface 'C1' of the Eurobalise (see SUBSET-036 [N6]).

6.3.2 Data Rate

The data rate R_d on the Interface 'C_L1' shall be

$$R_d = 9.5674 \text{ kHz} \pm 70 \text{ ppm.}$$

6.3.3 Telegram Lengths

For the Euroloop, a short telegram with $L_S = 341$ data bits and a long telegram with $L_L = 1023$ data bit shall be used in accordance with [N6].

6.3.4 Coding Requirements

6.3.4.1 Barker and Line Coding

Every data bit of the Euroloop telegram shall be further encoded with an 11 bit Barker code and subsequently Differential Bi-Phase-Level (DBPL) line coded as follows:

- Step 1: Barker Coding

Each telegram data bit shall be encoded in 11 chips according to a Barker code (Barker-chips). As a consequence the Barker chip rate

$$R_{BC} = 1/T_{BC} = (R_d \cdot 11)$$

is 11 times the data rate R_d . The symbol T_{BC} denotes the duration of a Barker chip.

- A logical 1 data bit shall be encoded as 11100010010 Barker chip sequence.
- A logical 0 data bit shall be encoded as 00011101101 Barker chip sequence.

- Step 2: Line Coding

The Barker chip sequences shall be DBPL encoded according to Figure 6-6 and the description below.

- The DBPL encoded Barker chips show a change of level at the centre of every chip period.
- A logical 1 is represented by a level change at the beginning of the chip period.
- A logical 0 is represented by no level change at the beginning of the chip period.

This coding results in a polarity independent signal. Therefore, interchanging the two signal wires does not affect data transmission.

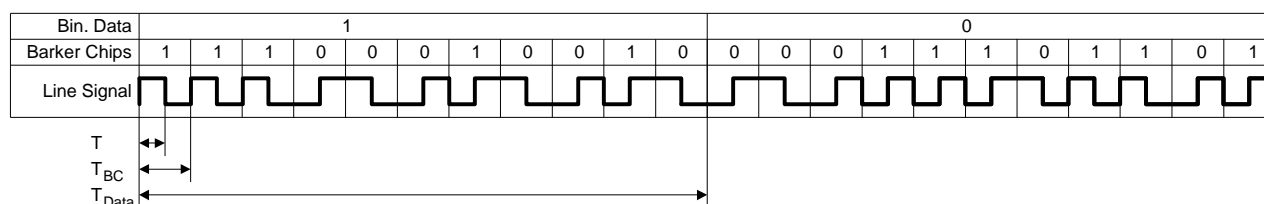

Figure 6-6: Differential Bi-Phase-Level Coding Scheme

The resulting signal shall appear on the Interface 'C_L1'.

6.3.5 Functional Requirements

Accidental short circuit for infinite time to the signal of Interface 'C_L1' shall not permanently damage any connected equipment.

6.3.6 Handshaking and Re-Sending

No handshaking shall be performed on Interface 'C_L1'.

6.3.7 Eye Diagram

The signal on Interface 'C_L1' into a resistive 120 Ω load shall fulfil the requirements according to Figure 6-7 and Table 6-2. The shaded areas constitute a mask into which the signal shall not enter (considering the actual mean data rate and the actual V_2 signal level).

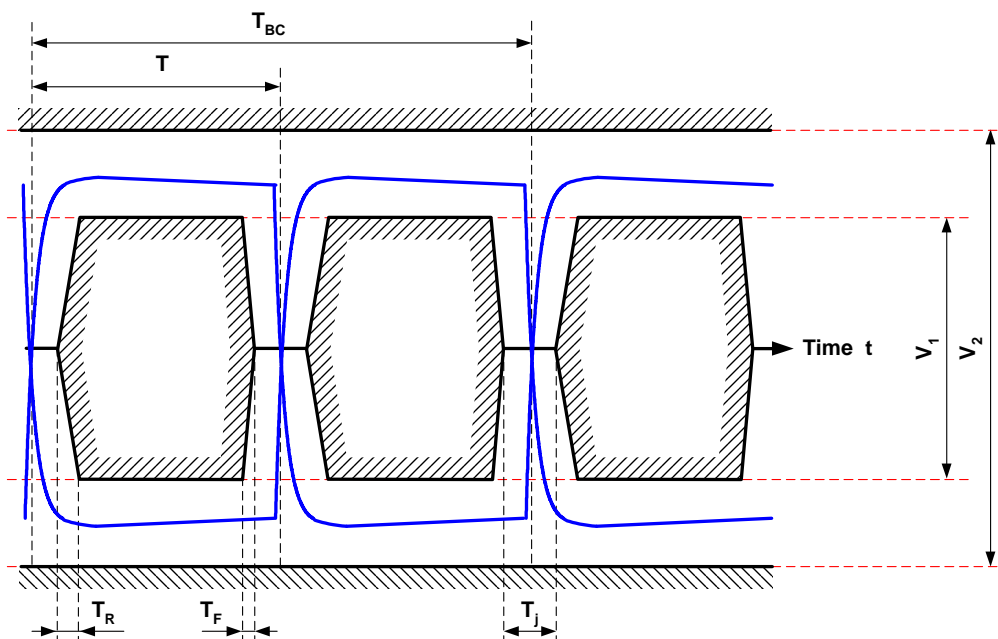

Figure 6-7: Transmit Pulse Shape Measured into a Resistive 120 Ω Load

The electrical parameters of Interface 'C_{L1}' shall be in accordance with Table 6-2 and Figure 6-7.

Table 6-2: Electrical Interface 'C_{L1}' Specifications

Parameter	Specification	Conditions
Return Loss	> 6 dB	within frequency range 50 kHz to 250 kHz into the ELS Nominal Impedance $Z = 120\Omega$
Transmit peak-to-peak voltage	$V_{2max} = 18.0 V_{pp}$ $V_{2min} = 14.0 V_{pp}$ $V_1 = 0.6 \cdot V_2$	<ul style="list-style-type: none"> into 120 Ω resistive load Shall not be DC coupled.
Eye diagram	According to Figure 6-7 with $T_R = 500$ ns and $T_F = 325$ ns.	into 120 Ω resistive load
Rise and fall time	> 100 ns	10% to 90% with 120 Ω resistive load
Half of Barker chip duration	$T = \text{actual } T_{BC}/2$	averaged over > 1 s. (see also sub-clause 6.3.4.1)
Overall tolerance for superposition of jitter and intersymbol interference	$T_j < 0.5 \mu s$	into 120 Ω resistive load

6.4 Interface 'C_{L2}' – Error Indication of LOOMO

Interface 'C_{L2}' is optional. It shall indicate the error status of the LOOMO. If the error status indicates the occurrence of an error, the LOOMO shall change to the stand-by mode (not transmit an up-link signal on Interface 'CA_L').

This interface shown in Figure 6-7 shall be made up of a switch which

- is closed (low impedance) if no error has been detected within the LOOMO.
- is open (high impedance) if an error has been detected within the LOOMO.

The control input of this switch shall be galvanically separated from the working contact of the switch.

Additionally, the specifications detailed in Table 6-3 shall apply.

Table 6-3: Interface 'C_{L2}' Specification

Parameter	Value	Condition
Max. switching capacity	< 1 A	at < 30 VDC, DC Resistive Load
	< 0.2 A	at < 100 VDC, DC Resistive Load
	< 1 A	at < 300 VAC, AC Resistive Load
Max. contact resistance or Min. load current	< 200 mΩ > 10 mA	at ≥ 5 VDC
Delay between occurrence of error within LOOMO and high impedance state of corresponding relay contact.	≤ 1.0 s	

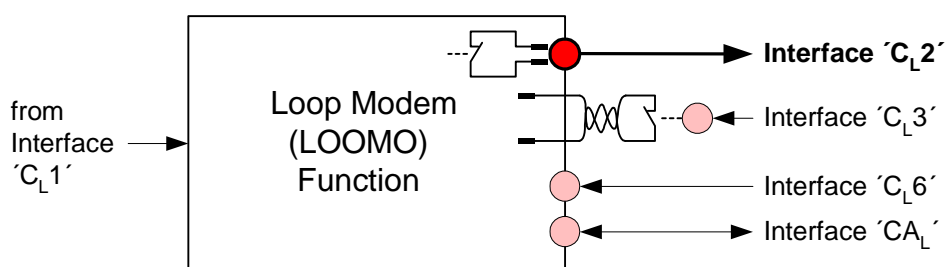

Figure 6-8: Error Indication Interface 'C_{L2}' of LOOMO

6.5 Interface 'C_{L3}' – External Activation of LOOMO

This interface shall allow an external activation of the LOOMO.

This interface shall be made up of a switch which has to be closed (low impedance) to activate the LOOMO. The control input of this switch shall be galvanically separated from the working contact of the switch. The switch can be placed outside the LOOMO (see Figure 6-9).

The control signal is application specific. The type of the switch and the cable between the switch and the LOOMO is supplier specific.

The specifications stated in Table 6-4 shall apply.

Table 6-4: Interface 'C_{L3}' Specifications

Parameter	Value	Condition
Current I_3	$4 \text{ mA} \leq I_3 \leq 50 \text{ mA}$	Contact closed
Voltage U_3	$3 \text{ V} \leq U_3 \leq 30 \text{ V}$	Contact open

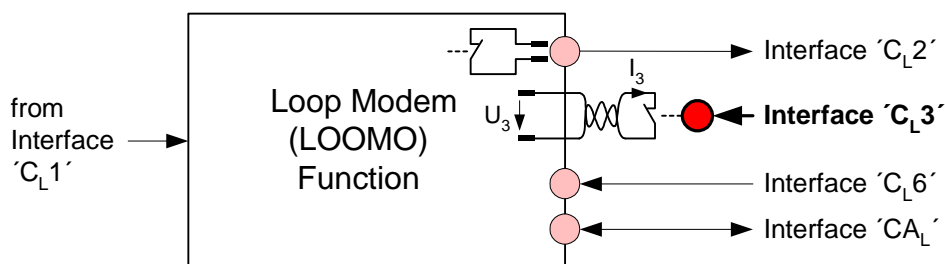

Figure 6-9: External Activation Interface 'C_{L3}' of LOOMO

6.6 Interface 'C_{L6}' – External Power Source of LOOMO

The LOOMO uses an external power source. The power supply is assumed to be in accordance with [N3].

The LOOMO shall not consume more than 150 VA.

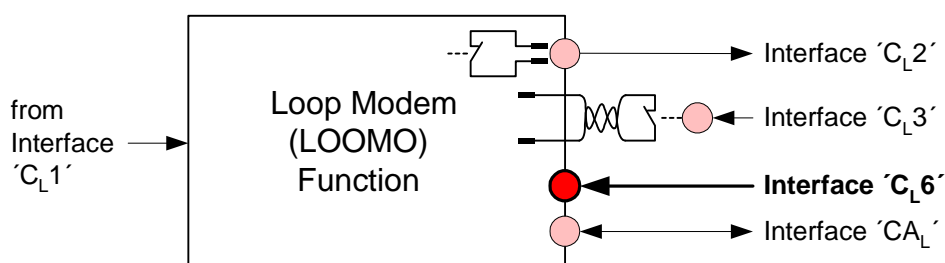

Figure 6-10: External Power Source Interface 'C_{L6}' of LOOMO

6.7 Interface 'CA_L' - Up-link Data from LOOMO to ELC

6.7.1 Overview

The Interface 'CA_L' is located between the LOOMO and the Jumper Cable. The Jumper Cable interconnects the LOOMO with the Euroloop Leaky Cable (ELC). This is shown in Figure 6-11.

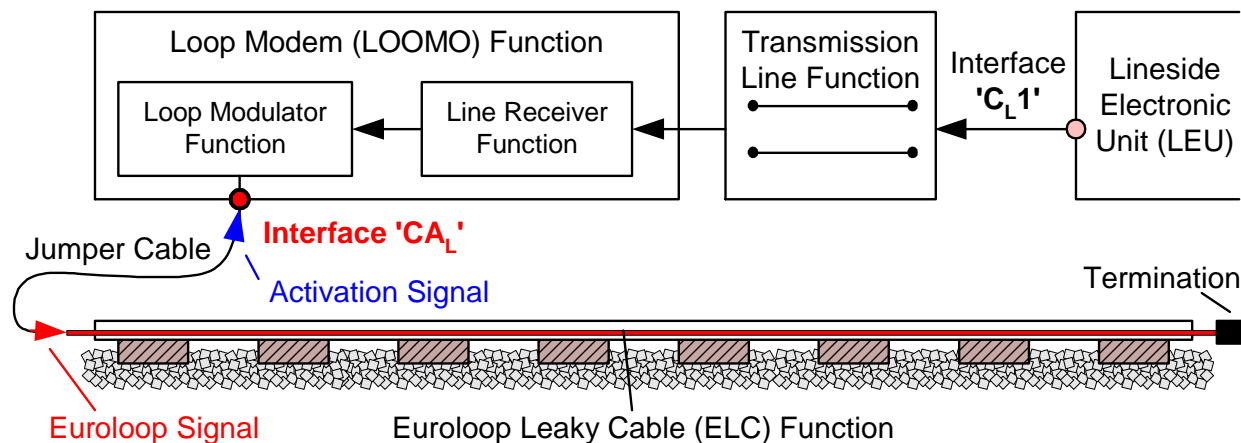

Figure 6-11: Signal Transmission between LOOMO and ELC

The LOOMO shall contain a Line Receiver function and the Loop Modulator function.

6.7.2 Line Receiver Function

The Line Receiver function shall decode the received signal. This includes the removal of the Differential Bi-Phase-Level (DBPL) encoding and the Barker code from the data stream received from the Interface 'C_L1'. The obtained recovered binary data stream shall be fed to the Loop Modulator function.

When the LOOMO can not receive a signal with sufficient quality from Interface 'C_L1', it shall be deactivated within a time frame of $t_{\text{dact}} \leq 100 \text{ ms}$.

6.7.3 Loop Modulator Function

6.7.3.1 General

The Loop Modulator function shall modulate the recovered binary data stream onto the centre frequency f_c using the Direct Sequence Spread Spectrum (DSSS) modulation scheme, and data is locked to the chip clock of the spreading code. Each binary data symbol shall be Differential Binary Phase Shift Keying (DBPSK) modulated with a complete period of the spreading code, the so-called SSCode (see Annex F). The result is a polarity independent spread spectrum modulated data stream.

The DSSS modulation function and coding function shall be performed according to the principles shown in Figure 6-12. These principles provide a detailed functional description of the DSSS modulation and coding scheme in the form of a block diagram (Figure 6-12) and a timing diagram (Figure 6-13). The block diagram does neither stipulate a mandatory way to realize the DSSS modulation, nor the coding scheme. Various arrangements of such a modulator may be used to generate the required signal.

As indicated in Figure 6-12, the Binary Data D, the Differential Data DD, the Recovered Data Clock DCK, the Chip Clock CCK, the Chip Sequence CHS, and the Modulated Chips MCH are all synchronous to each other but the Raw Carrier RC and the Raw Signal RS are not.

The signals indicated in Figure 6-12 are provided in Figure 6-13 for a simplified example of a 7-chip-SSCode of the sequence (1, 1, 0, 0, 1, 0, 1). In reality the code length N_c is much larger (see sub-clause 6.7.3.3).

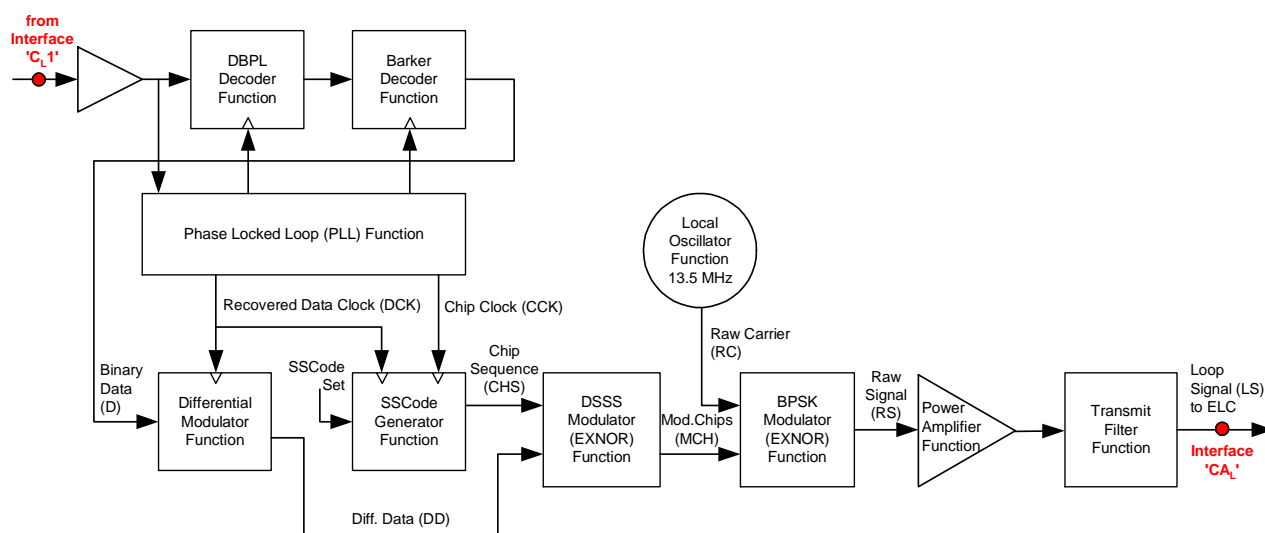

Figure 6-12: Principles of DSSS Modulator: Functions Associated with Modulation (Informative)

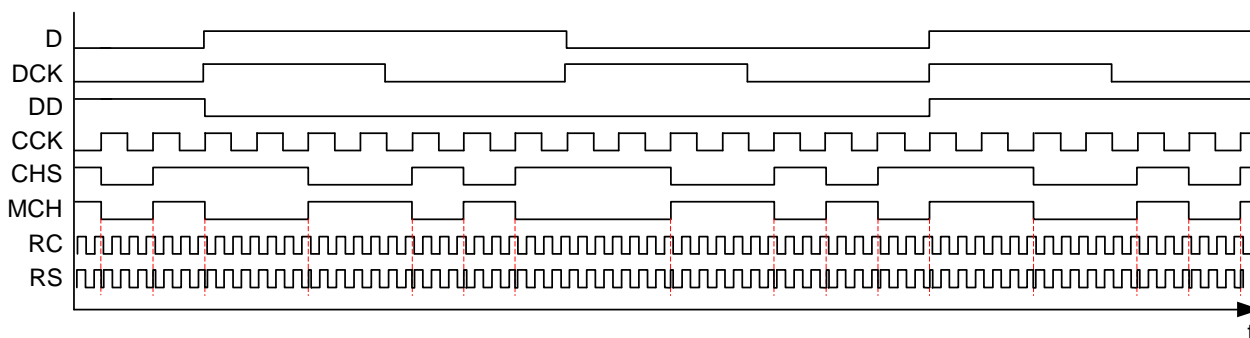

Figure 6-13: Signals Associated with DSSS Modulation (Informative)

6.7.3.2 Differential Modulator Function

The data D shall be converted to Differential Data DD before used for modulation. The output DD of the differential modulator shall toggle with every clock pulse of the Data Clock DCK only if data input D is low.

6.7.3.3 SSCode Generator Function

The start and period of the spreading code sequence (SSCode) shall coincide with the corresponding data symbols to be coded (see Figure 6-12 and Figure 6-13). The implementation of the SSCode generator shall perform the same function as proposal in Figure 6-12.

6.7.3.4 Chip Rate and SSCode Length

The chip rate R_c shall be N_c times the data rate R_d (see sub-clause 6.3.2). The number N_c of chips of each SSCode, the so-called code length, shall be $N_c = 472$.



$$R_c = R_d \cdot N_c \text{ (approx. 4.5 Mchip/s).}$$

The sixteen (16) available SSCodes are specified in Table F- 1 Annex F.

6.7.3.5 DSSS Modulation Function

The DSSS modulator shall Binary Phase Shift Keying (BPSK) modulate a complete SSSCode sequence of length N_c onto each Differential Data DD symbol. Hence, the duration of the DD symbol shall coincide with the duration of an SSSCode period.

The Chip Sequence CHS signal in Figure 6-13 shows a section of an SSSCode sequence. This BPSK modulation might be implemented using an EXNOR. The result is the Modulated Chip sequence MCH (see Figure 6-13).

6.7.3.6 BPSK Modulator Function

The BPSK Modulator shall modulate the Raw Carrier RC with the Modulated Chip Sequence MCH. Depending on the value of the Modulated Chip sequence MCH the Raw Carrier RC shall be either inverted (180 degree phase shifted) or not inverted. In Figure 6-12 this BPSK modulation is implemented by an EXNOR which combines the Raw Carrier RC with the Modulate Chip sequence MCH. The result is the Raw Signal RS.

6.7.4 Maximum Time Interval Error

The Maximum Time Interval Error (MTIE) of the modulation signal (MCH, see Figure 6-12 and Figure 6-13) which was used to modulate the carrier (see Figure 6-12) shall be within any observation interval t_{ob}

$$MTIE < t_{ob} \cdot 70 \text{ ppm} + 40 \text{ ns.}$$

The MTIE shall be measured by analysing the output signal at Interface 'CA_L' (see SUBSET-103, [N5]).

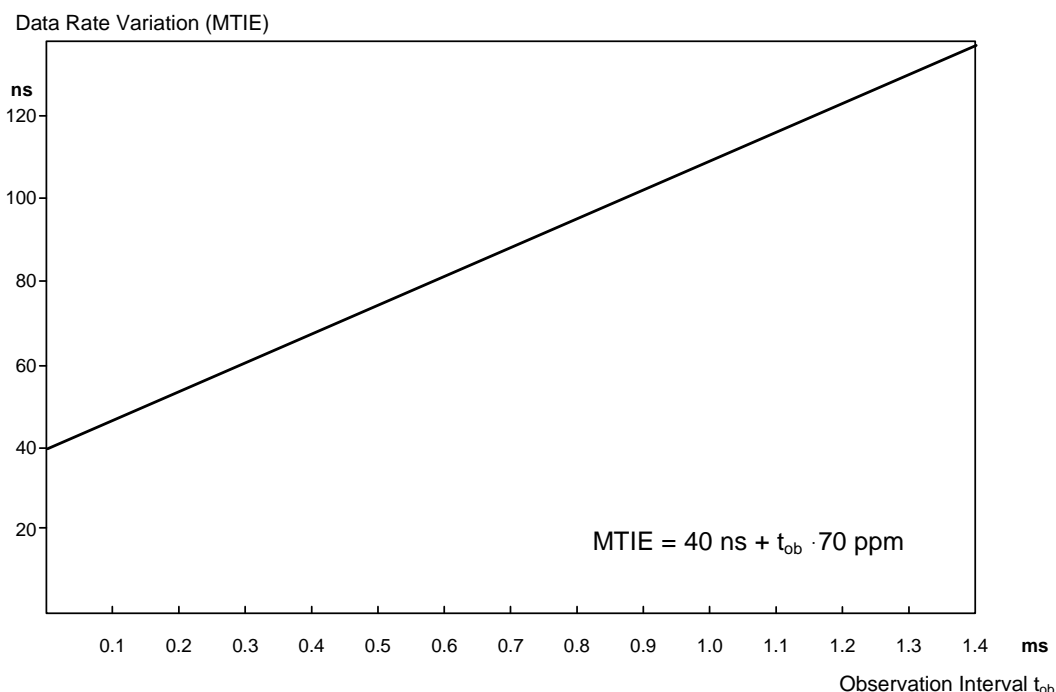

Figure 6-14: MTIE of the Modulation Signal

6.7.5 Raw Carrier

The centre frequency f_c of the Euroloop signal in the air gap shall be

$$f_c = 13.54750 \text{ MHz} \pm 30 \text{ ppm.}$$

The Single Sideband (SSB) phase noise shall comply with Figure 6-15. For the purpose of measuring this SSB phase noise at Interface 'CA_L' it shall be possible to switch the modulation signal (e.g. the Modulated Chip sequence MCH, see Figure 6-12) off.

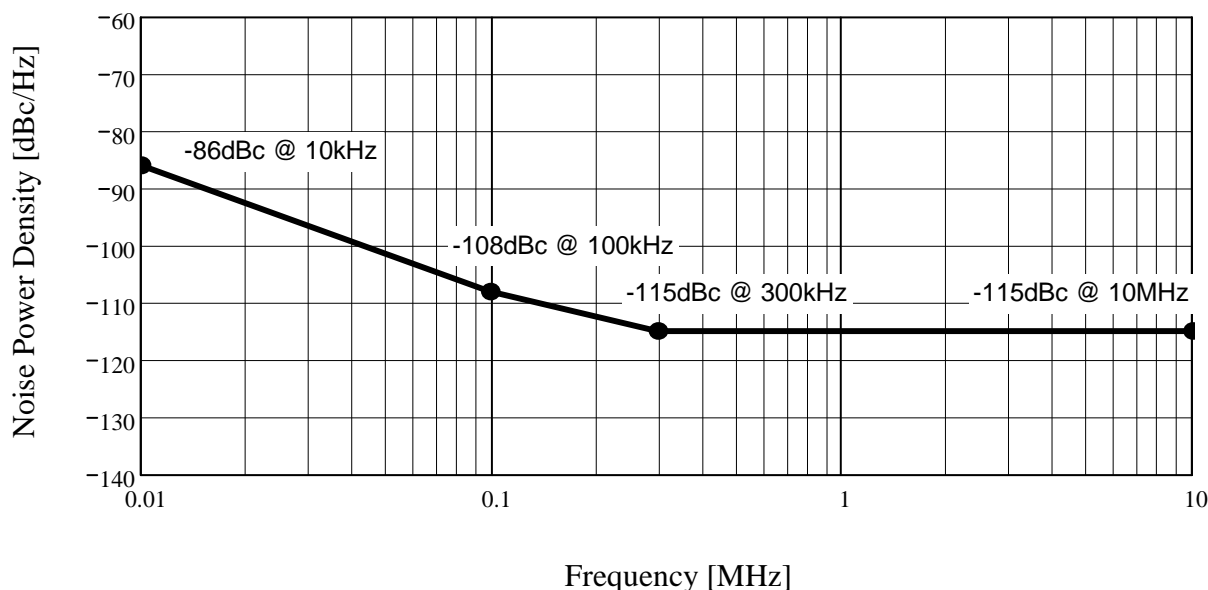

Figure 6-15: Single Sideband (SSB) Phase Noise of the Raw Carrier

6.7.6 Quality of LOOMO's Output Signal

The quality of the LOOMO's output signal $s(t)$ on Interface 'CA_L' is defined by the Bit Error Ratio, the unintentional Amplitude Modulation and the modulation distortion.

The Bit Error Ratio shall be $<10^{-5}$

The unintentional Amplitude Modulation shall be $\leq 7\%$

The modulation distortion is defined by the magnitude of the Complex Correlation Function $CCF(\tau)$ of the normalised signal $s_{cb}(t)$ with the SSCode $c_{15}(t)$.

$$CCF(n \cdot \Delta\tau) = \frac{1}{K} \sum_{k=1}^K s_{cb}((k+n) \cdot \Delta\tau) \cdot c_{15}(k \cdot \Delta\tau),$$

where $\Delta\tau$ denotes the nominal equidistant sampling intervals, $K = \text{floor}(T_d / \Delta\tau)$, $T_d = 1/R_d$ with R_d the data rate specified in sub-clause 6.3.2, and $n \in \{0, 1, 2, \dots, K-1\}$.

- The output signal $s(t)$ of the LOOMO shall be generated using
 - only data symbols of logical ones ("1") values and
 - the test SSCode number 15 as defined in Table F- 1 of Annex F.
- $s_{cb}(t)$ shall be sampled over an interval T_{sc} , where $T_{sc} = \text{floor}(2 \cdot T_d / \Delta\tau + 1)$.
- $s_{cb}(t)$ shall be the normalised complex base-band signal of $s(t)$.

© This document has been developed and released by UNISIG

- The normalisation of $s_{cb}(t)$ shall be with respect to the maximum amplitude of $|s(t)|$ at the end of the SSCode chip period².
- $c_{15}(n \cdot \Delta\tau)$ shall be the test SSCode number 15³ as defined in Table F- 1 of Annex F sampled over one period of the SSCode, i.e. the duration T_d of a data symbol. Its amplitude shall take on the values +1, or –1 provided the corresponding chips in Table F- 1 takes on the logical value “1”, or “0”, respectively.
- τ denotes the time delay relative to the peak of the magnitude of $CCF(\tau)$.

Let $CCF_i(n \cdot \Delta\tau)$, and $NCF_i(n \cdot \Delta\tau)$ denote, respectively, the i^{th} ($i \in \{1, 2, \dots, N_g\}$) measurement of $CCF(n \cdot \Delta\tau)$, and $NCF(n \cdot \Delta\tau)$ with

$$NCF(n \cdot \Delta\tau) = CCF(n \cdot \Delta\tau) / \max_n \{ |CCF(n \cdot \Delta\tau)| \}.$$

$NCF(n \cdot \Delta\tau)$ is subsequently referred to as the Normalised Correlation Function (NCF).

The quality of LOOMO’s output signal $s(t)$ shall be such that the average over $N_g = 5$ different measurements

- of $CCF(n \cdot \Delta\tau)$ complies with

$$\frac{1}{N_g} \sum_{i=1}^{N_g} \max_n \{ |CCF_i(n \cdot \Delta\tau)| \} \geq 0.85.$$

- of the magnitude $|NCF(n \cdot \Delta\tau)|$ of the Normalised Correlation Function $NCF(n \cdot \Delta\tau)$ complies simultaneously with all specifications detailed in Table 6-5 and Figure 6-16.

² The amplitude of signal $s(t)$ might show a ringing at the beginning of a data symbol period. To avoid normalising $s_{cb}(t)$ with respect to largest amplitude of this ringing, the normalisation of $s_{cb}(t)$ shall take place with respect to the largest amplitude of $s(t)$ at the end of the data symbol periods.

³ The requirements addressed by sub-clause 6.7.6 focus on the quality of the up-link signal on Interface ‘CA_L’ due to distortions of the ideal signal by the signal processing within the LOOMO, e.g. filtering.

Table 6-5: Specification of Mask Shown in Figure 6-16

Parameter	Value	Condition
$\Delta\tau_a = \frac{1}{N_g} \sum_{i=1}^{N_g} \tau_{a2i} - \tau_{a1i} $	$< 270 \text{ ns}$	$ NCF_i(\tau_{a1i}) = 0.5$ and $ NCF_i(\tau_{a2i}) = 0.5$ for $i \in \{1, 2, 3, \dots, N_g\}$ where τ_{a1i} and τ_{a2i} are obtained by linear interpolation between adjacent samples of $ NCF_i(n \cdot \Delta\tau) $.
$\frac{1}{N_g} \sum_{i=1}^{N_g} \max_n NCF_i(\tau_b \leq n \cdot \Delta\tau \leq T_d/2) $ <p style="text-align: center;">and</p> $\frac{1}{N_g} \sum_{i=1}^{N_g} \max_n NCF_i(-T_d/2 \leq n \cdot \Delta\tau \leq -\tau_b) $	$< 12\%$	$\tau_b > 250 \text{ ns}$, provided that the index n of the samples of $ NCF_i(n \cdot \Delta\tau) $ are rear- ranged such that the $\max_n NCF_i(n \cdot \Delta\tau) $ appears at $n = 0$, i.e. $n \cdot \Delta\tau = \tau = 0$.

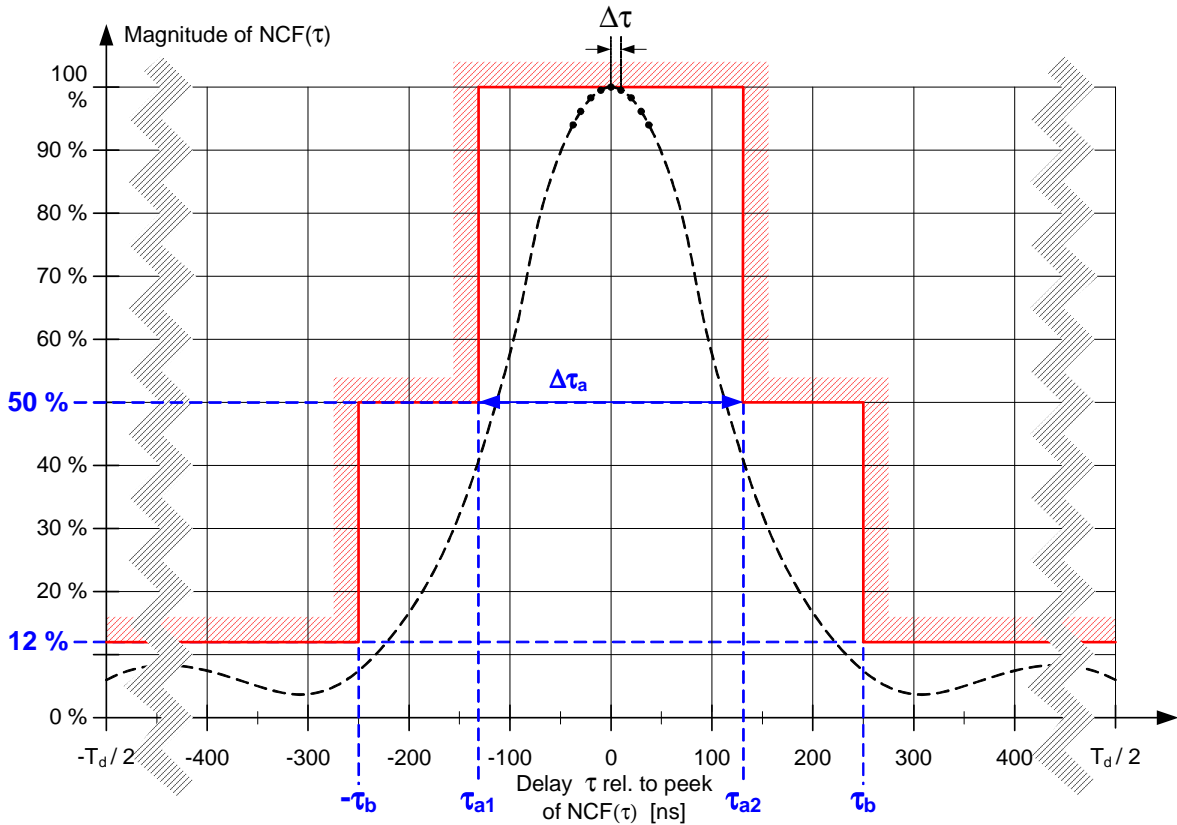

Figure 6-16: Mask for the Normalised Correlation Function $NCF(\tau)$

6.7.7 Spectrum Mask

The spectrum mask defines the limit lines for the power of the spectral components of the Euroloop up-link signal at the Interface 'CA_L'. These limit lines are relative to the power of the maximum spectral component of the Euroloop up-link signal, i.e. 0 dB corresponds to the maximum spectrum component of the Euroloop up-link signal.

The limits lines of the spectrum mask of the Euroloop up-link signal shall not exceed the values given in Figure 6-17. These limits apply for a measurement bandwidth of 10 kHz using a RMS detector.

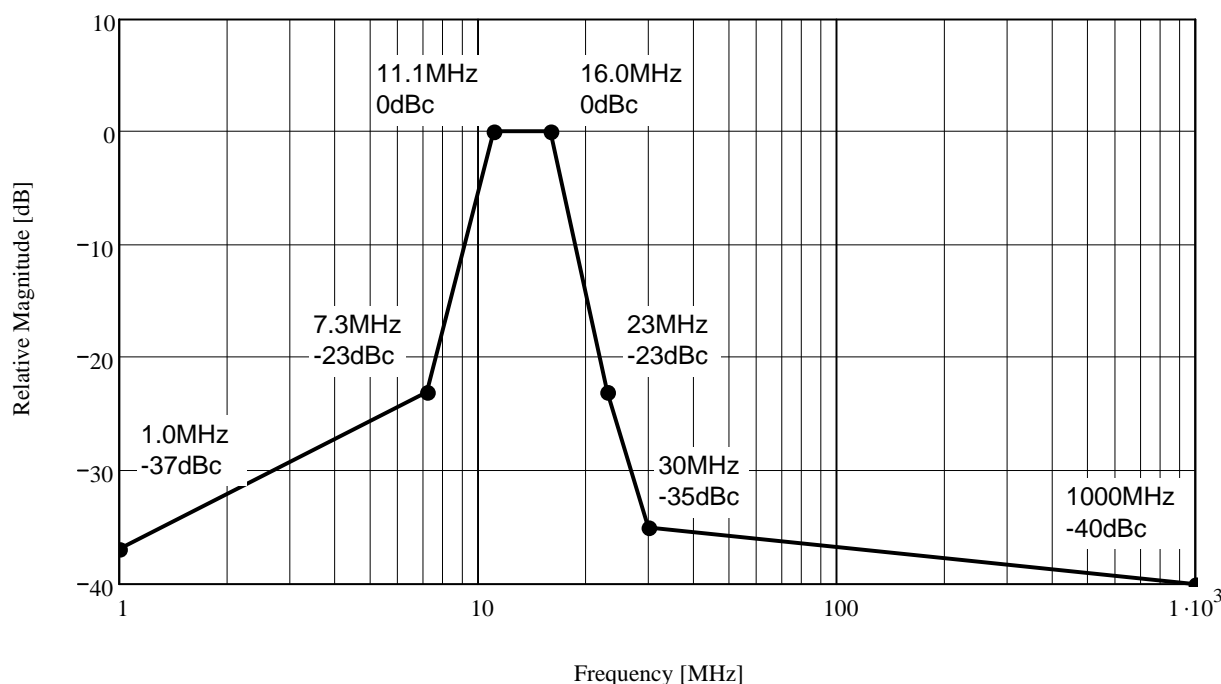

Figure 6-17: Spectrum Mask of Euroloop Up-link Signal

6.7.8 Impedance and Return Loss

The Interface 'CA_L' shall comply with the specifications detailed in Table 6-6.

Table 6-6: General 'CA_L' Interface Specifications

Parameters	Specifications	Conditions
Return Loss into LOOMO	≥ 8 dB	<ul style="list-style-type: none"> 27.095 MHz ±5 kHz At nominal impedance at Interface 'CA_L' into LOOMO Nominal impedance 50Ω

6.8 Air Gap Interface

6.8.1 Overview

The air gap Interfaces 'A_L4' and 'A_L1' are located between the ELC and the Antenna Unit (AU) function of the On-board Equipment.

Interface 'A_L4' is used for the transmission of the activation signal from the On-board to the Track-side Equipment.

Interface 'A_L1' is used for the transmission of the up-link Euroloop signal from the Trackside to the On-board Equipment. Figure 6-18 shows the two Euroloop air gap interfaces.

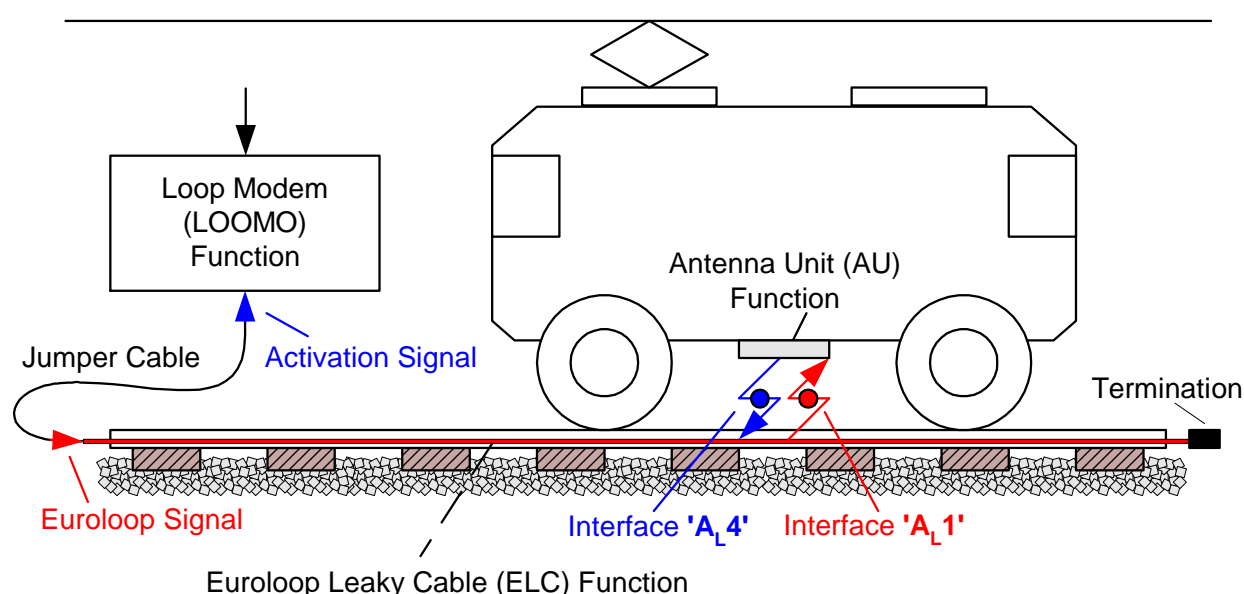

Figure 6-18: Air Gap Interfaces 'A_L4' and 'A_L1'

6.8.2 Interface 'A_L4' – Euroloop Activation

6.8.2.1 General Requirements

The properties of the activation signal on Interface 'A_L4' shall comply with the requirements specified in SUBSET-036 [N6] for the 'A4' Interface. This activation signal shall be picked up by the ELC. The nominal installation position of the ELC in the inner or outer foot of the rail is specified in sub-clause 6.10.7.

6.8.2.2 Maximum Magnetic Flux of Activation Signal

For the magnitude of the maximum magnetic flux Φ_{Lmax} , the limit⁴ of

$$\Phi_{Lmax} = 250 \text{ nVs}$$

applies within the frequency range $27.095 \text{ MHz} \pm 5 \text{ kHz}$ at the nominal installation position of the Euroloop Leaky Cable specified in sub-clause 6.10.7 using the Reduced Size Reference Loop (RSRL) specified in sub-clause 6.12.3.2.

⁴ More than one (1) On-board Antenna can be actively transmitting the activation signal within the same Loop Section.

6.8.2.3 Activation and Deactivation of LOOMO by Activation Signal

The LOOMO shall be activated by the presence of the activation signal on Interface 'A_L4'. This activation signal shall comply with the requirements stated in the FFFIS for Eurobalise [N6].

The activation time is important for the trackside installation rules detailed in sub-clause 6.10.

Provided that the activation signal on Interface 'A_L4' is used to activate the LOOMO,

1. the LOOMO shall start transmitting the Euroloop telegram into the air gap (Interface 'A_L1') upon the presence of the magnetic flux of the activation signal whose magnitude Φ_{TE} complies with

$$\Phi_{TE} \geq \frac{\Phi_L}{M_\Phi}$$

$$M_\Phi = M_{\Phi 0} \cdot 10^{\frac{L_{max} \cdot \alpha}{20}}$$

- Where Φ_L The magnetic flux Φ_L is specified in sub-clause 7.3.3.
- L_{max} The maximum cable length in meter
- α The cable specific attenuation in dB/m at 27 MHz
- $M_{\Phi 0}$ $M_{\Phi 0} = 0.25$ is the calibration constant for cable length zero that accounts for the difference between the Euroloop Reference Tool (ERT) specified in sub-clause 6.12.3.3 and the real Euroloop trackside environment

The attenuation of the signal due to the type and length of the cable shall be taken into account by the LOOMO. The corresponding measurement procedure is specified in SUBSET-103 [N5].

2. the LOOMO shall start transmitting the Euroloop telegram into the air gap (Interface 'A_L1') within the time frame t_{start}

$$t_{start} \leq 105 \text{ ms}$$

provided that the activation signal is present as specified in point 1 above.

3. the LOOMO shall remain activated for the time t_{on} with

$$60 \text{ s} < t_{on} \leq 90 \text{ s.}$$

Then the LOOMO shall become deactivated⁵.

Figure 6-19 shows the flow diagram for the activation of the LOOMO by the activation signal from Interface 'A_L4'.

⁵ To sense the presence of the activation signal, the LOOMO may be deactivated to prevent the masking of the activation signal by spurious and harmonics of the Euroloop signal.

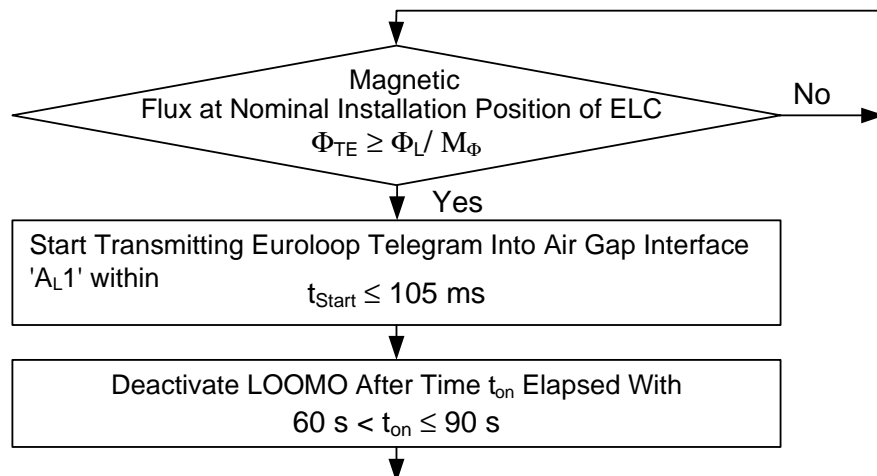

Figure 6-19: Flow Diagram for Activation of LOOMO by Activation Signal from Interface 'A_{L4}'

6.8.3 Interface 'A_L1' - Up-link Data Transmission

6.8.3.1 Electric Field in the Air Gap

No requirements on the electric field generated by the signal radiated from the installed Euroloop Leaky Cable shall be met except the EMC ones defined in sub-clause 6.13.

6.8.3.2 Magnetic Field Strength in the Air Gap

6.8.3.2.1 Magnetic Field Strength Limits

With reference to Figure 6-20, the magnitude $|H_z|$ of the z-component H_z (see Figure 5-3) of the magnetic field strength H of the wanted Euroloop Up-link signal at the reference position in the air gap (see sub-clause 5.5) without train

- shall remain between 32 dB μ A/m and 67 dB μ A/m for
90% of type M Loop section,
98% of type S Loop section
at approval of each installation.
- shall remain between 26 dB μ A/m and 73 dB μ A/m for
90% of type M Loop section,
98% of type S Loop section
after approval of each installation.

The indicated magnetic field strength limits shall be measured within a 3 dB resolution bandwidth of 4.5 MHz centred at the centre frequency f_c of the Euroloop signal (see sub-clause 6.7.5). All limits are RMS levels.

6.8.3.2.2 Magnetic Field Strength Margins

The magnetic field strength along the track is affected e.g. by

- trackside debris,
- positions of the AU relative to the reference position (see sub-clause 5.5.2),
- weather conditions such as temperature or humidity,
- ageing, e.g. the laying of the ELC within the foot of the rail, and
- tolerances of system components.

To account for realistic combinations of the above mentioned influences a margin of

± 6 dB for trackside influences

is accounted for in the magnetic field strength limits after approval of installation as mentioned above.

The resulting magnetic field strengths limits are illustrated in Figure 6-20.

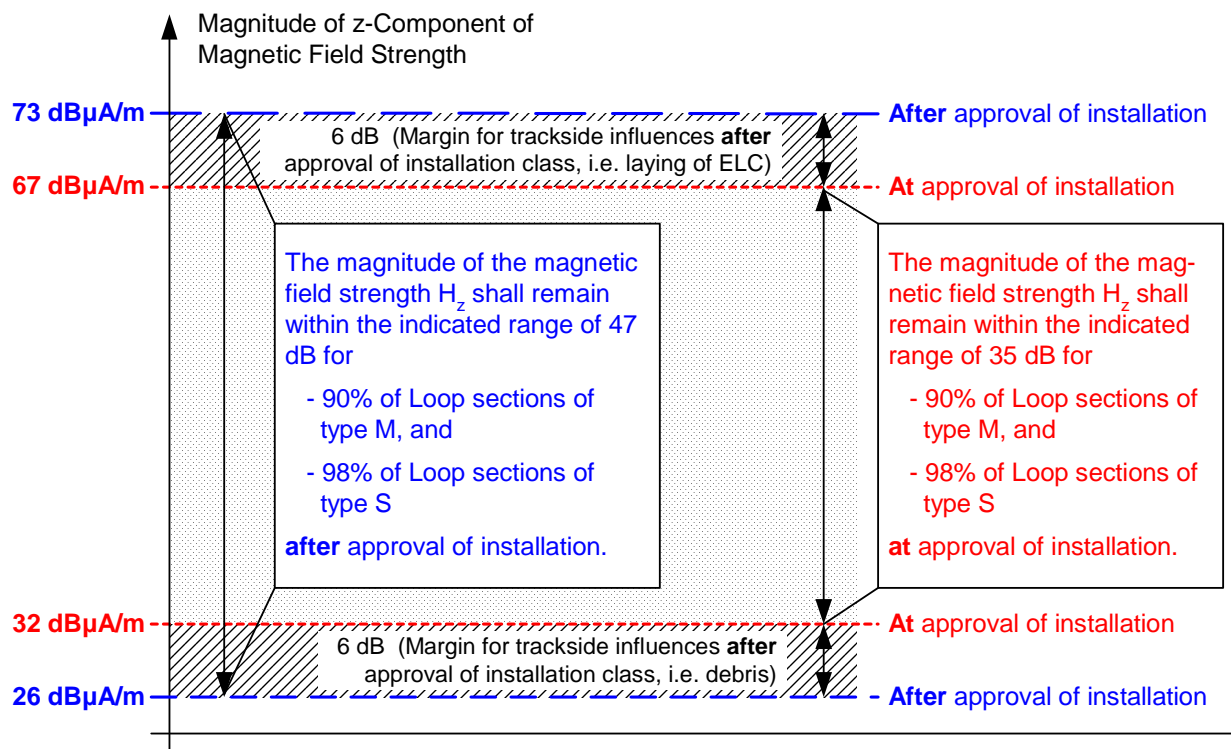

Figure 6-20: Limits of Magnitude of z-Component $|H_z|$ of Magnetic Field Strength H with Margins for Trackside Installations

6.8.3.3 Emission into the Environment

The emissions of the Trackside Equipment to the environment is detailed in sub-clause 6.13.2.



6.9 Environmental Conditions

6.9.1 General Conditions

The Trackside Equipment should fulfil the applicable requirements of EN 50125-3 [N25].

6.9.2 Sealing, Dust and Moisture

The ELC should provide the IP67 environmental rating as defined in EN 60529 [N4].

The environmental rating for the LOOMO should be defined by the manufacturer.

As a minimum, the LOOMO shall comply with IP20.

6.9.3 Debris (Informative)

The debris layers accounted for within the margins of the magnetic field strength are e.g., water, snow, ice, ballast, sand, mud, iron ore, iron dust, coal dust, oil, and grease. Justification for the margins stated in sub-clause 6.8.3.2.2 and 7.3.2 are provided in Annex C.

6.10 Trackside Installation Rules

6.10.1 Maximum Length of Loop Sections

The installation rules shall be defined by the manufacturer and should be in accordance with rules of the trackside infrastructure operator. General installation rules are provided in Annex D.

It shall be possible to operate a Loop section⁶ of a length of up to 1000 m.

6.10.2 Minimum Length of Loop Section

The minimum length of the Loop section shall allow for the transmission of at least three (3) times N_D data symbols for trains with velocities up to the train speed v_T stated in sub-clause 5.3.1. $N_D = 1100$ data symbols which accounts for 1023 data symbols of a long Euroloop telegram plus at least 77 extra telegram data symbols as required for the decoding of the Euroloop telegram (see sub-clause on “coding requirements” in SUBSET-36). See sub-clause 5.4.4.2 for the corresponding availability of the ELS.

6.10.3 Distance between EOLM and Loop Section

The distance between the EOLM and the Loop section should be such that trains running at train speed v_T (see sub-clause 5.3.1) activate the On-board Equipment before reaching the Loop section.

For Loop sections which are not optimised for minimum length the distance can be shorter. It is also allowed to place an EOLM within a Loop section.

6.10.4 Minimum Distance between Loop Sections with Same Q_SSCODE

To prevent reliability cross talk in parallel Euroloop arrangements, Euroloops with the same assigned SSCode but different assigned Loop messages and different Loop Identity Numbers (NID_LOOP) shall be installed with a minimum distance between the closest points of their Trackside Equipments of at least 50 m in horizontal and vertical direction to adjacent tracks and at least 300 m along the track.

6.10.5 Signal-to-Interference Ratio

It shall be possible that Euroloops are activated simultaneously, and transmission of respective Loop messages is performed simultaneously without creating reliability cross-talk.

The Signal-to-Interference Ratio (SIR) denotes the ratio between the magnitude of the z-component of the magnetic field strength of the wanted Euroloop signal $H_{zw_Euroloop}$ to the sum of the corresponding magnetic field strengths $H_{zu_Euroloop}$ of the unwanted Euroloop signals with different SSCode along the Loop section.

The Signal-to-Interference Ratio (SIR) shall be better than the negative value of the Co-channel Rejection for Wideband (CRWB) A_{CRWB} detailed in sub-clause 7.5.2.4.3, i.e.

$$SIR \geq - A_{CRWB}.$$

The SIR shall be met for Euroloop arrangements in parallel tracks. Where double Euroloops are installed this will not be possible in all cases. Where it is not possible a degraded system reaction time can occur in rare situations at stopping locations. Trackside engineering solutions have to be defined if this is not acceptable, e.g. deactivation of loop at red signal.

⁶ see sub-clause 4.3 for a definition of the Loop section.

6.10.6 Euroloop Leaky Cable Requirements

The properties of the Euroloop Leaky Cable (ELC) installed in the inner or outer foot of the rail according to the specifications given in sub-clause 6.10.7 shall allow the fulfilment of the air gap requirement stated in sub-clause 6.8.2 for Interface 'A_L4' and 6.8.3.2 for Interface 'A_L1'.

In addition to the above requirement, any type of passive leaky coaxial cable can be used provided that the requirements stated in Table 6-7, Table 6-8 and Table 6-9 are met.

The cable should be of coupled mode type exhibiting no significantly dominant launch angle radiation / reception in radial direction.

Table 6-7: General Requirements for Leaky Cable itself.

Parameter	Value	Condition
Power Return loss RL $RL = -10 \cdot \log \left(\frac{1}{f_2 - f_1} \cdot \int_{f_1}^{f_2} S_{11} ^2 \cdot df \right)$	≥ 16 dB	<ul style="list-style-type: none"> 9 MHz to 27.1 MHz at nominal impedance of leaky cable with nominal impedance termination
Nominal impedance	Z _{cable} = 50 Ω, constant along cable	9 MHz to 27.1 MHz
Surface transfer impedance according to IEC 62153-4-3 [N28] (informative)	0.5 mΩ/m to 2.0 mΩ/m	at 13.5 MHz
Diameter of outer conductor	11 mm to 33 mm	
Max. distance a _{max} of centre of leaky cable from nominal installation position	see sub-clause 6.10.7	
Min. distance a _{min} of outer conductor of leaky cable from inner or outer foot of rail	1.5 mm	
Environmental conditions	According to sub-clause 6.9.	

Table 6-8: Requirements for Termination.

Parameter	Value	Condition
Power return loss RL $RL = -10 \cdot \log \left(\frac{1}{f_2 - f_1} \cdot \int_{f_1}^{f_2} S_{11} ^2 \cdot df \right)$	≥ 16 dB	<ul style="list-style-type: none"> 9 MHz to 27.1 MHz at nominal impedance of leakycable
Nominal impedance	Z = 50 Ω	9 MHz to 27.1 MHz
Environmental conditions	According to sub-clause 6.9.	

Table 6-9: Requirements for optional Common Mode Chokes.

Parameter	Value	Condition
Power return loss RL $RL = -10 \cdot \log \left(\frac{1}{f_2 - f_1} \cdot \int_{f_1}^{f_2} S_{11} ^2 \cdot df \right)$	≥ 15 dB	<ul style="list-style-type: none"> 9 MHz to 27.1 MHz with nominal impedance termination
Nominal impedance	$Z = 50 \Omega$	9 MHz to 27.1 MHz
Environmental conditions	According to sub-clause 6.9.	

Following parameters depend on the specific application and should be specified by the supplier, in order to meet the magnetic field strength limits for the according loop section as defined in sub-clause 6.8.3.2.1:

- coupling loss⁷,
- longitudinal attenuation (cable loss),
- diameter over jacket.

⁷ The magnetic field strength in the air gap depends not only on the coupling loss of the cable but also on the output power of the LOOMO, the distance a_{\min} and the type of sleeper.

6.10.7 Installation of Euroloop Leaky Cable

The Euroloop Leaky Cable (ELC) shall be clamped to the inner or outer foot of the rail within distance intervals of maximum 3 m.

Figure 6-21 defines the nominal installation position of the ELC. The cable shall typically stay within the lateral limit of the foot of the rail. Deviations from this nominal installation position of the ELC are allowed for e.g.

- elongation and contraction of the ELC caused by climatic variations,
- mounting tolerances of the ELC, and
- by-passing rail side obstacles such as axle counters, isolation joints, guide rails, points, and crossings.

The maximum deviation of the ELC from its nominal installation position in the inner or outer foot of the rail shall be

$$a_{\max} < 140 \text{ mm.}$$

The ELC shall not be allowed to enter the railway loading gauge. Additionally, the ELC shall not enter the zone specified by the distances

$$C_1 = \frac{1}{2} \cdot H, \text{ and } C_2 = 100 \text{ mm}$$

from the Top of Rail (see Figure 6-21), where $D = 0.5 \text{ m}$ from the middle of the track, and H denotes the height of the rail.

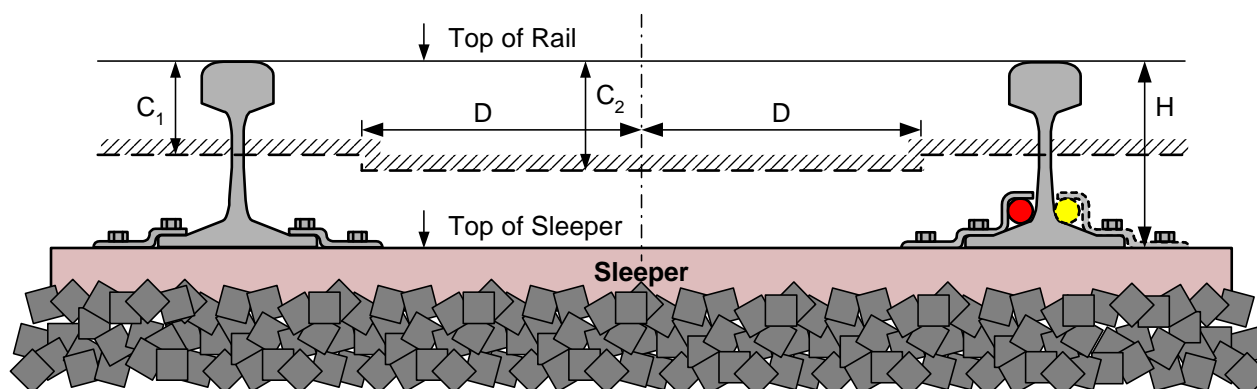

Figure 6-21: Nominal Installation Position of ELC with Indication of Possible Attachment Method to the inner and outer Foot of the Rail

The supplier should define installation rules which cover at least following parameters:

- type of cable,
- position of cable (inner or outer foot of the rail),
- type of rail profile (e.g. UIC 60),
- type of sleeper (concrete, wooden, steel),
- type of clamps and distance between clamps,
- max. distance cable – rail,
- the standardised ELC Reference Tool (ERT) defined in sub-clause 6.12.3.3 considers the worst case situations with respect to all points above, and
- arrangements for track “distortions” as rail joints, points, metal objects (e.g. guard rails).



Within a loop section it shall be allowed to change from the inner to the outer foot of the rail and/or to change from one rail to the other within the same track. For such situation the supplier should define an additional installation rule which covers at least following parameter:

- type of crossing cable (e.g. standard coaxial jumper cable)⁸.

A jumper cable should leave the rail in an almost right angle to reduce field strength peaks.

In case of double Euroloop arrangements the cable segments should both be placed in the inner foot or both in the outer foot of the two rails. Using different positions to balance the field strength is not allowed.

6.10.8 Assignment of Spreading Code

The SSCode assigned to the transmission of each Euroloop Trackside Equipment shall be identical to the one transmitted by the corresponding EOLM to the On-board Equipment.

6.10.9 Quality of Installation

6.10.9.1 Magnetic Field Strength of Euroloop Signal

The trackside installation shall provide the Quality of Installation (QoI) detailed below for sub-section of Type M and S (see sub-clause 6.1.2).

1. The QoI for moving trains (QoIM) is defined by the total length of the range of x-positions at the reference position (see sub-clause 5.5.2) along the track within a Loop section, where
 - the magnitude $|H_{zw}|$ of the z-component H_{zw} of the magnetic field strength H_w of the wanted Euroloop signal remains within the limits stated in sub-clause 6.8.3.2, divided by the length of this Loop section. The QoIM shall be 90% minimum.
 - the magnitude $|H_{zu}|$ of the z-component H_{zu} of the magnetic field strength H_u of the sum of the un-wanted Euroloop signals remains within the limits given by $|H_{zw}|$ recorded under point 1 above plus the limit for the Signal-to-Interference Ratio (SIR) as stated in sub-clause 6.10.5, divided by the length of this Loop section. The QoIM shall be 90% minimum.
2. The QoI for trains at standstill (QoIS, associated to Type S sub-sections only) is defined by the probability, that
 - the magnitude $|H_{zw}|$ of the z-component H_{zw} of the magnetic field strength H_w of the wanted Euroloop signal remains within the limits stated in sub-clause 6.8.3.2 at any reference position (see sub-clause 5.5.2) within the sub-section. The QoIS shall be 98% minimum.
 - the magnitude $|H_{zu}|$ of the z-component H_{zu} of the magnetic field strength H_u of the sum of the un-wanted Euroloop signals remains within the limits given by $|H_{zw}|$ recorded under point 2 above plus the limit for the Signal-to-Interference Ratio (SIR) as stated in sub-clause 6.10.5, divided by the length of this Loop section. The QoIS shall be 98% minimum.

⁸ If a leaky cable is used for crossings a magnetic field strength at the reference position might be generated which violates the limits stated in sub-clause 6.8.3.2.1 and therefore might contribute to a reduction of the QoI as specified in sub-clause 6.10.9.

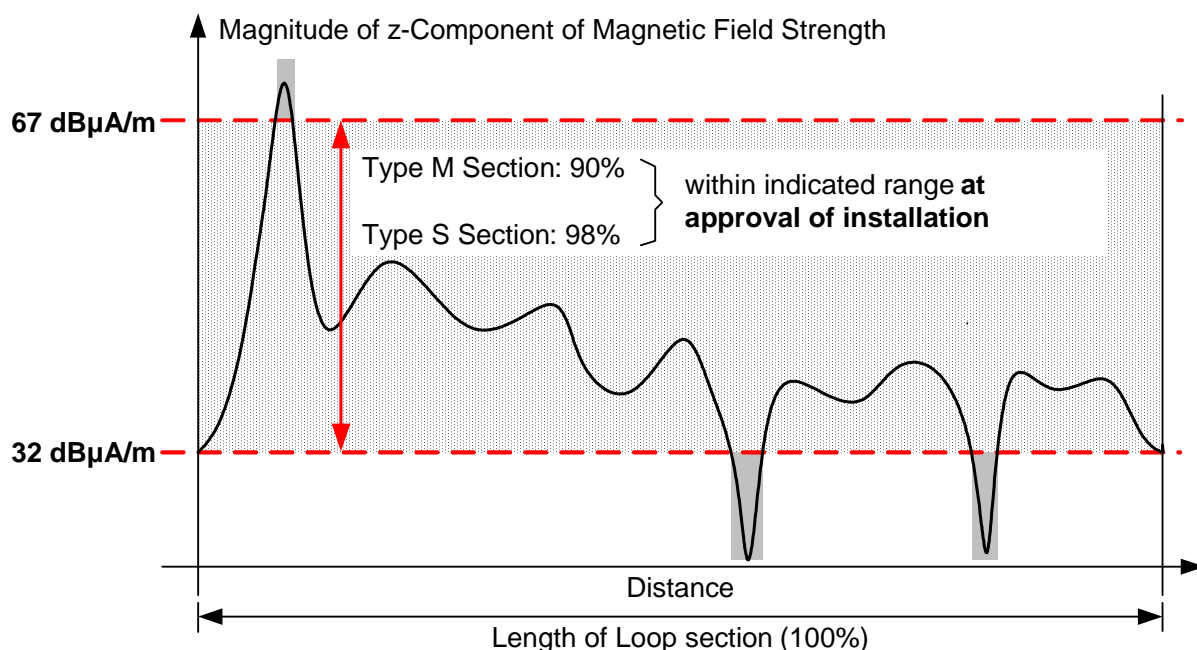

Figure 6-22: Limits on the Magnitude of z-Component of Magnetic Field Strength in the Air Gap at the Reference Position for Loop Sections of Type M and S

6.11 Specific Electrical Requirements

6.11.1 General

During normal operation, as well as in accidental conditions, the installation of the Trackside Equipment and the related controlling interface cables shall be provided with suitable means to ensure:

- protection of persons against electric shock hazard (e.g., stepping over the ELC of the LOOMO);
- protection of equipment against damage due to over-voltage.

6.11.2 Protective Provisions Relating to Electrical Safety and Earthing

Applicable parts of EN 50122-1 [N23] shall apply.

6.11.3 Insulation Co-Ordination

For the insulation co-ordination EN 50124-1 [N19] applies.

6.11.4 Dielectric Tests

Dielectric tests shall be carried out on specimen of typical arrangements of LOOMO with the LOOMO controlling interface cable, in order to verify the fulfilment of the insulation requirements of sub-clause 6.11.3 above. Tests shall be organised and carried out in accordance with Annex B of EN 50124-1 [N19].

6.12 Test Requirements

6.12.1 General

This sub-clause lists the test tools required to test the Trackside Equipment. The specifications of these test tools are provided in the SUBSET-103 entitled “Test Specification for Euroloop” [N5].

6.12.2 Test Signals

The Test Signals for the On-board Equipment are defined in SUBSET-103 [N5].

6.12.3 Test Tools

6.12.3.1 Magnetic Field Probe

For the measurement of magnetic field strengths, the Magnetic Field Probe (MFP) shall be standardised.

The MFP shall comply with the requirements stated in Table 6-10 below.

Table 6-10: Specifications of Magnetic Field Probe

Parameter	Value	Condition
Type of Antenna	Magnetic Field Antenna (Loop Antenna)	
Loop Area A_{MFP}	$A_{MFP} = 0.0195 \text{ m}^2 \pm 5\%$	
Height / Length Ratio of Loop	$1.115 \pm 5 \%$	Rectangular
Cross-Polarisation Isolation (Min.)	> 10 dB	5 MHz to 30 MHz
Electric Field Rejection	> 20 dB	5 MHz to 30 MHz

6.12.3.2 Reduced Size Reference Loop

For the measurement of the magnetic flux of the activation signal on Interface ‘A_L4’ in the air gap, the Reduced Size Reference Loop (RSRL) in longitudinal position specified in SUBSET-036 shall be used [N6]. The longitudinal position is defined by the longest side of the RSRL parallel to

- the x-axis of the rail for measurements of the z-component of the magnetic flux,
- the z-axis for measurements of the x- and y-component of the magnetic flux.

The area of this Loop shall be 200 mm × 390 mm, see sub-clause 5.2.2.4 in SUBSET-036.

6.12.3.3 ELC Reference Tool

The ELC Reference Tool (ERT) is a model of the track with ELC at its nominal installation position (see sub-clause 6.10.7). The ERT shall be used as receiving antenna to test the activation of the LOOMO by the activation signal from Interface 'A_{L4}'. The activation signal requirements are specified in sub-clause 6.8.2.

This tool

1. shall be a model of the real environment,
2. shall be no longer than 6 m to be suitable for laboratory environment,
3. shall include a return path for the signal currents,
4. shall model the influence of sleepers,
5. shall include a model for the rails, and
6. shall include a model of the Euroloop Leaky Cable (ELC) in the foot of the model of the rails.
7. shall allow the rotation of the ELC around its longitudinal axis.

The ERT shall be standardised.

6.12.4 Test Mode

LOOMO's operated in "test mode" transmit the un-modulated Euroloop signal of centre frequency f_c as specified in sub-clause 6.7.5 irrespective of the state of the activation / deactivation of the LOOMO detailed in sub-clause 6.2.4. This mode of operation shall only be used for testing purposes.

6.13 EMC Requirements

6.13.1 Emission – Excluding Aspects Related to the Air Gap

The applicable EMC standard for Trackside Equipment (TE) is EN 50121-4 [N3].

The Trackside Equipment shall comply with the emission requirements stated in Table 6-11.

Table 6-11: Emission Requirements for Trackside Equipment

Topic	Standard	Reference
Enclosure	EN 50121-4 [N3]	Clause 5
AC or DC terminals, Signal lines	EN 50121-4 [N3]	Clause 5

6.13.2 Emission – Aspects Related to the Air Gap

- The magnetic field-strength at 10m from the ELC shall comply with EN 302 609 [N26].
- The out-band emission limits from the ELC shall comply with the EN 302 609 [N26].

Measurements to prove compliance with EN 302 609 [N26] are required only for type approval of equipment and ELC installation type.

6.13.3 Immunity

Immunity requirements for Trackside Equipment (TE) are specified in EN 50121-4 [N3].

The Trackside Equipment shall comply with the immunity requirements stated in Table 6-12.

Table 6-12: Immunity Requirements for Trackside Equipment

Topic	Standard	Reference
Enclosure	EN 50121-4 [N3]	Table 1
Input and Output	EN 50121-4 [N3]	Table 2
DC Power Ports	EN 50121-4 [N3]	Table 3
AC Power Ports	EN 50121-4 [N3]	Table 4
Ground Connection	EN 50121-4 [N3]	Table 5

The requirements do neither apply for the in-band frequency range defined in sub-clause 6.13.2, nor for the frequency range ± 500 kHz centred on the nominal frequency of 27.095 MHz of the activation signal.

7 ON-BOARD EUROLOOP SUBSYSTEM

7.1 Architectural Layout

The modules of the On-board Equipment are shown in Figure 7-1. It shall consist of the following functions:

- the Antenna Unit (AU) function,
- the Loop Receiver (LR) function, and
- the Loop Decoder (LD) function.

The Loop Transmission Module (LTM) function consists of the LR, and the LD. The Balise Transmission Module (BTM) function and the LTM function should preferably share a common Antenna Unit (AU) function, see Figure 7-1 and Figure 5-2. Some constraints on antenna installation are defined in SUBSET-036 [N6] and SUBSET-040 [N15].

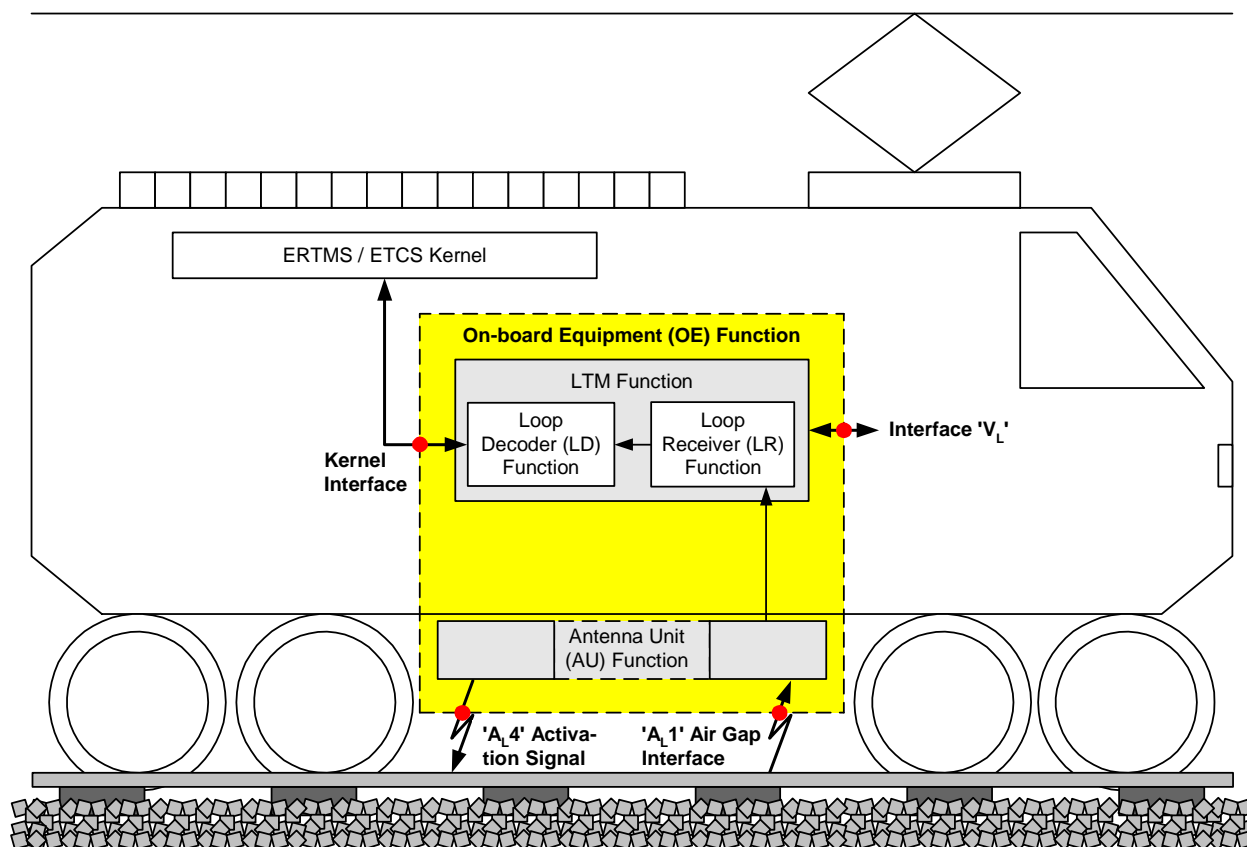

Figure 7-1: On-board Equipment of Euroloop Subsystem



7.2 Functional Requirements

7.2.1 Loop Receiver Function

The data signal (serial binary bit stream) as generated in the LEU shall be retrieved from the Euroloop signal received at the air gap Interface 'A_L1', and decoded data shall be transmitted to the ERTMS/ETCS Kernel function.

7.2.2 Loop Decoder Function

The Loop Decoder function shall decode the data signal (serial binary bit stream) received from the Loop Receiver according to SUBSET-036 [N6], i.e., extracting the User Bits of the information coded according to the Eurobalise Coding Strategy detailed in SUBSET-036 [N6].

7.3 Air Gap Interfaces

7.3.1 Overview

Figure 7-2 shows the two air gap interfaces of the On-board Equipment:

- Interface 'A_{L1}' for the transmission of the Euroloop signal from the Trackside Equipment function to the On-board Equipment function.
- Interface 'A_{L4}' for the transmission of the activation signal from the On-board Equipment function to the Trackside Equipment function.

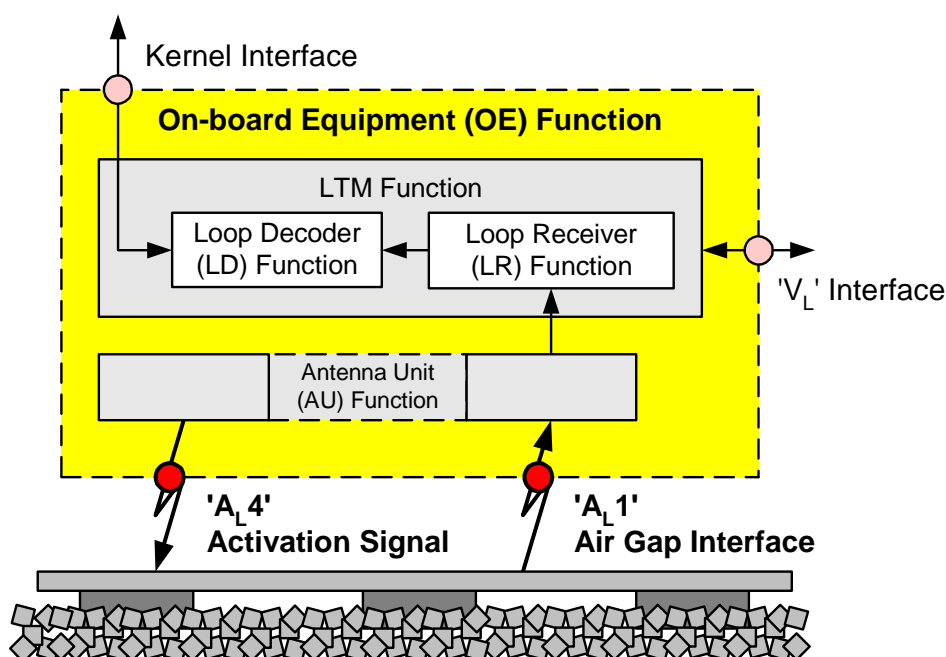

Figure 7-2: Air Gap Interfaces of On-board Equipment

7.3.2 Interface 'A_{L1}' - Air Gap Interface

With reference to Figure 7-3, the On-board Equipment shall comply with all its requirements provided that the magnitude of the z-component $|H_z|$ of the magnetic field strength H of the wanted Euroloop signal at the reference position in the air gap (see sub-clause 5.5) is

- | | |
|-----------------------------------|--|
| $\leq 76 \text{ dB}\mu\text{A/m}$ | as upper limit for the On-board Equipment, and |
| $\geq 23 \text{ dB}\mu\text{A/m}$ | as lower limit for the On-board Equipment |

within the 3dB resolution bandwidth of 4.5 MHz centred at the centre frequency f_c of the Euroloop signal (see sub-clause 6.7.5). The limits stated above include a margin of

$\pm 3 \text{ dB}$ that accounts for the influence of the presence of the train.

Figure 7-3 illustrates these limits.

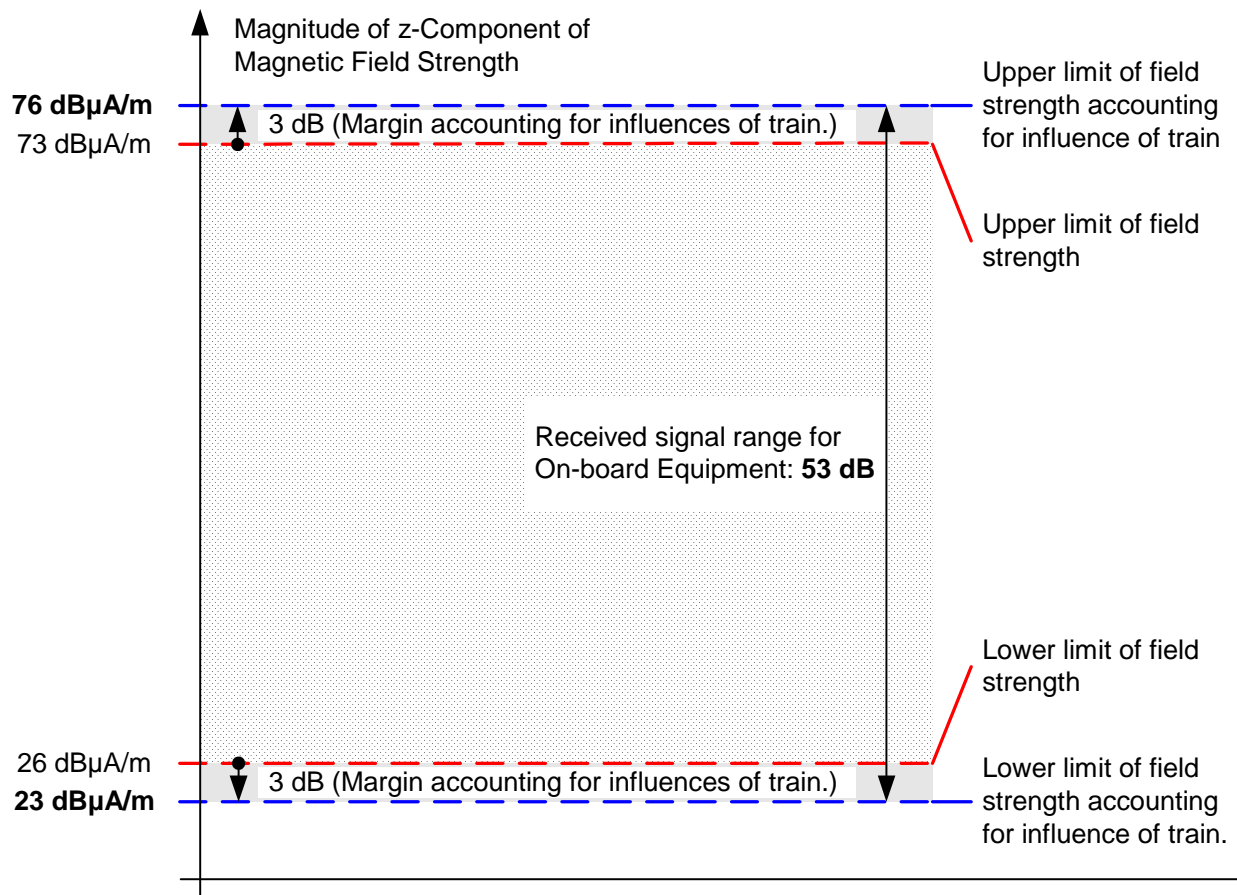

Figure 7-3: Limits of the Magnitude of the z-Component $|H_z|$ of the Magnetic Field Strength H with Margins for On-board Equipment

7.3.3 Interface 'A_{L4}' – Activation Signal

The On-board Equipment shall provide the activation signal compliant to the requirements specified in SUBSET-036 [N6] for the Tele-powering signal of frequency 27.095 MHz \pm 5 kHz on the air gap Interface 'A_{L4}'.

The subsequently listed requirements apply for the contact zone of the air gap Interface 'A_{L4}' specified in sub-clause 6.10.7.

- The magnitude $\Phi_L = \sqrt{\Phi_{Lx}^2 + \Phi_{Ly}^2 + \Phi_{Lz}^2}$ of the activation signal at the location of the air gap Interface 'A_{L4}', i.e. in the “trackside free air environment”, shall comply with

$$\Phi_L \geq 0.1 \text{ nVs,}$$

where Φ_{Lx} , Φ_{Ly} , and Φ_{Lz} denote, respectively, the corresponding components in the directions of the x-, y-, and z-axis (see sub-clause 5.5.1). The magnetic fluxes Φ_{Lx} , Φ_{Ly} , and Φ_{Lz} shall be measured

- with the Reduced Size Reference Loop (RSRL) specified in sub-clause 6.12.3.2. Please observe the orientation of the RSRL specified in sub-clause 6.12.3.2.
- within a bandwidth of 10 kHz centred at 27.095 MHz.
- in the “trackside free air environment”, i.e. in the absence of any metal objects in the vicinity of the measurement locations. The measurement locations shall coincide with the nominal installation position of the ELC in the inner or outer foot of the rail as specified in sub-clause 6.10.7.
- while varying the mounting, i.e. pitch, yaw, tilt, etc. of the Antenna Unit function surrounded by its metallic box (see SUBSET-085, [N11]) within the limits stated in SUBSET-085 [N11] to obtain the minimum magnetic flux Φ_L at the measurement locations specified above.
- The deviation of the magnetic flux Φ_{OE} from the Antenna Unit, due to debris and proximity of conductive material, relative to the magnetic flux form in free air, shall be considered by the Antenna Unit design.
- Debris and the proximity to conductive material may influence the efficiency of the Antenna Unit itself. Such influence shall be within the specified limits for the performance of the Antenna Unit.
- The measurement procedure to test the On-board Equipment's capability to provide the required magnetic flux Φ_L is specified in SUBSET-103 [N5].

7.4 Kernel Interface

7.4.1 Overview

Figure 7-4 shows the location of the Kernel Interface of the On-board Equipment.

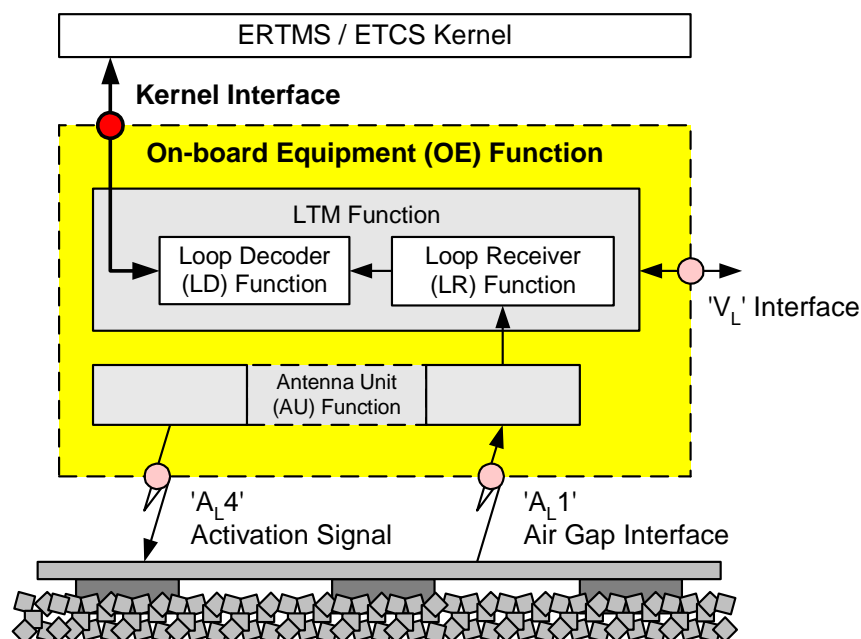

Figure 7-4: Kernel Interface of On-board Equipment

This interface of the LTM Function is used to send and receive data, respectively, to and from the ERTMS/ETCS Kernel.

7.4.2 Functional Requirements

It is not standardized but it shall be able to transfer three categories of data:

- Send the received Loop telegram towards the ERTMS/ETCS Kernel. The message format is according to chapter 8 of SUBSET-026[N10].
- Receive particular information such as the Spread Spectrum Code Number (Q_SSCODE) from the ERTMS/ETCS Kernel. For details on the subject see chapter 7 [N9] and chapter 8 [N10] of SUBSET-026. This information is provided by the End of Loop Marker (EOLM) located near the beginning of the Loop section to the ERTMS/ETCS Kernel. The ERTMS/ETCS Kernel then transfers only the Q_SSCODE to the Loop Receiver (LR).

7.4.3 Information Sent by EOLM to On-board Equipment

According to chapter 7 of SUBSET-026 [N8] the EOLM sends the Q_SSCODE before the beginning Loop section to the On-board Equipment to prepare it for the reception of the Loop telegrams.

7.4.4 Timing Requirements

The timing requirements on system level are specified in the Performance Requirements for Interoperability, SUBSET-041 [N16].

7.5 Interface 'V_L' – Test Interface

7.5.1 Overview

This is an interface used for testing various properties of the LTM function. In particular, it includes a specific subset designed for testing the On-board functionality of the Euroloop. The interface is not required to be integrated in the operational equipment. If the interface is not integrated into the operational equipment, a company specific adapter (allowed to be external to the operational equipment) shall be used for providing the standardised interface. A detailed description of Interface 'V_L' is given in "Test Specification for Euroloop" SUBSET-103 [N5].

This Interface incorporates the subsequent signals:

- Demodulated output data of the Loop Receiver with associated clock signal.
- Transmit (LR_TXD) and receive (LR_RXD) control line signals between the LTM Function and the ERTMS / ETCS Kernel Function allowing to instruct the Loop Receiver about the Q_SSCODE to be used.

Figure 7-5 shows the location of the Interface 'V_L' of the On-board Equipment.

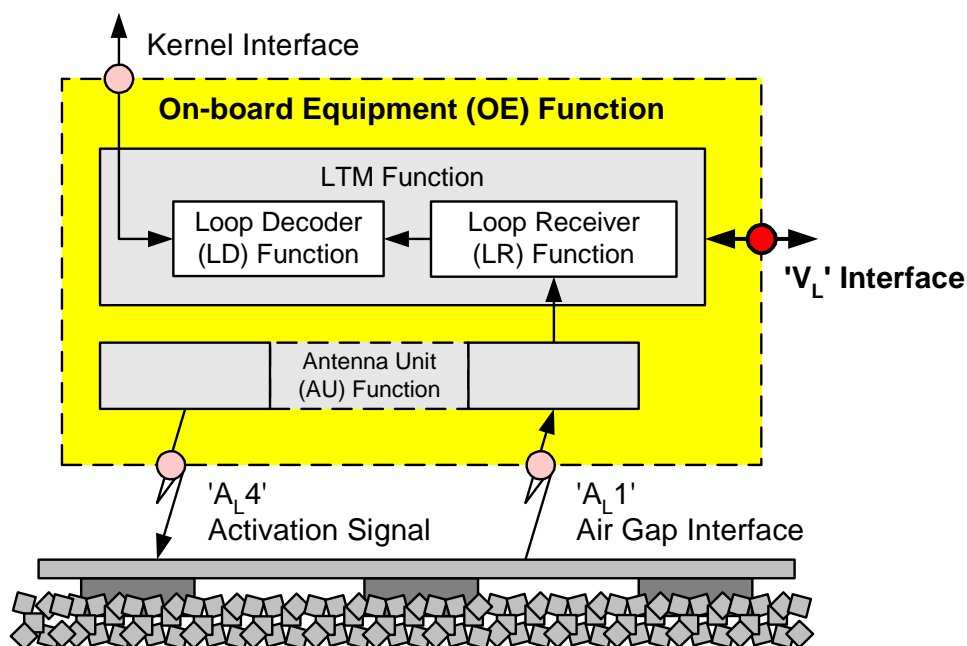

Figure 7-5: Interface 'V_L' of On-board Equipment

7.5.2 Receiver Performance Requirements

The receiver performance parameters apply for all SSCodes listed in Table F- 1 of Annex F.

Additionally, all receiver parameters apply for the full dynamic range of the On-board Equipment as specified in sub-clause 7.5.2.1.2 and 7.5.2.1.3 for the z-component $H_{zw-Euroloop}$ of the wanted Euroloop signal.

The magnetic field strengths of the wanted and unwanted Euroloop signal shall be measured within the 3 dB resolution bandwidth of 3 MHz centred on the centre frequency f_c of the Euroloop signal.

7.5.2.1 Dynamic Range of On-board Equipment

7.5.2.1.1 General

The dynamic range of the On-board Equipment is defined by the range of the received magnitudes of the z-component of the magnetic field strength in the air gap of a properly modulated Euroloop signal which will, without interference, produce after demodulation a data signal with a **BER_{DR}** of 1×10^{-4} or smaller.

7.5.2.1.2 Sensitivity

The On-board Equipment's sensitivity shall be **H_{SENS} ≤ 23 dBμA/m** (see also sub-clause 7.3.2).

7.5.2.1.3 Error Behaviour at High Wanted Input Signal Level

The upper limit for the dynamic range of the On-board Equipment shall be **H_{UL} ≥ 76 dBμA/m** (see also sub-clause 7.3.2).

7.5.2.2 Distortion Immunity

The Distortion Immunity (DI) is a requirement for the On-board Equipment to receive a wanted distorted Euroloop signal without exceeding a given degradation. This measurement is in terms of the type of signal distortion encountered within the trackside environment and the magnitude of the magnitude of the z-component of the magnetic field strength of the wanted Euroloop signal.

The degradation limit is defined by the Bit Error Ratio **BER_{DI} = 2.0 × 10⁻⁴** which shall not be exceeded.

7.5.2.3 Inter-modulation Immunity

The Inter-Modulation Immunity (IMI) is a requirement for the On-board Equipment to receive a wanted modulated Euroloop signal without exceeding a given degradation due to the presence of two or more unwanted signals with specific and different frequency relationships to the wanted Euroloop signal frequency. This measurement is in terms of the magnitude of the z-component of the magnetic field strength of the wanted and unwanted signals.

For the purpose of the present test exactly two (2) unwanted monochromatic signals shall be considered. The frequencies f_{u1} and f_{u2} of the two unwanted monochromatic signals shall be $f_{u1} = 4.5$ MHz and $f_{u2} = 27.095$ MHz. The magnitude H of the z-component H_z of the magnetic field strength, $H_{zu,IM}$, of the two unwanted monochromatic signals shall be equal.

The degradation limit is defined by the Bit Error Ratio **BER_{IMI} = 2.0 × 10⁻⁴** which shall not be exceeded.

The inter-modulation immunity level shall be **H_{zu,IM} ≥ 76 dBμA/m**.

7.5.2.4 Co-Channel Rejection

7.5.2.4.1 General

The co-channel rejection is a requirement for the On-board Equipment to receive a wanted modulated Euroloop signal without exceeding a given degradation due to the presence of one (1) unwanted signal located within the same frequency band as the wanted signal. This measurement is in terms of magnitude of the z-component of the magnetic field strength of the wanted and unwanted Euroloop signals.

7.5.2.4.2 Co-Channel Rejection for Narrowband Signal

The unwanted signal shall be a monochromatic signal whose frequency f_u equals the centre frequency f_c of the Euroloop system. This signal shall be represented by the magnitude of the z-component of the magnetic field strength $H_{zu,CRNB}$.

The degradation limit is defined by the Bit Error Ratio $BER_{CRNB} = 2.0 \times 10^{-4}$ which shall not be exceeded.

The co-channel rejection for narrowband signals A_{CRNB} is defined by $H_{zu,CRNB} / H_{zw,Euroloop}$ of the wanted and unwanted signals.

The Co-channel Rejection for Narrow Band (CRNB) signals shall be

$$A_{CRNB} \geq 25 \text{ dB.}$$

7.5.2.4.3 Co-Channel Rejection of Other Euroloop Signal

The unwanted signal shall be an undistorted Euroloop signal with an SSCode that differs from the wanted Euroloop signal. This signal shall be represented by the magnitude of the z-component of the magnetic field strength $H_{zu-Euroloop}$.

For the purpose of the present document only one (1) unwanted Euroloop signal shall be considered.

The degradation limit is defined by the Bit Error Ratio $BER_{CRWB} = 2.0 \times 10^{-4}$ which shall not be exceeded.

The co-channel rejection for wideband signals A_{CRWB} is defined as the ratio of

$$H_{zu-Euroloop} / H_{zw-Euroloop}$$

of the wanted and unwanted signals.

The Co-channel Rejection for Wideband (CRWB) signals shall be

$$A_{CRWB} \geq 1 \text{ dB.}$$

7.5.2.5 Blocking

The blocking is a requirement for the On-board Equipment to receive a wanted modulated Euroloop signal without exceeding a given degradation due to the presence of an unwanted modulated or un-modulated signal at any other frequency outside an exclusion band of 13.0 MHz below and above the centre frequency f_c of the wanted Euroloop signal. This measurement is in terms of magnitude of the z-component of the magnetic field strength of the wanted ($H_{zw_Euroloop}$) and unwanted ($H_{zu_Blocking}$) signals.

For the purpose of testing only one (1) unwanted monochromatic signal in the frequency-range 27.115 MHz to 30 MHz shall be considered.

The degradation limit is defined by the Bit Error Ratio $BER_{Blocking} = 2.0 \times 10^{-4}$ which shall not be exceeded.

The blocking capability shall be $H_{zu_Blocking} \geq 80 \text{ dB}\mu\text{A/m}$.

7.5.2.6 Dynamic Receiver Performance

The Dynamic Receiver Performance (DRP) is a requirement for the On-board Equipment to receive a wanted modulated Euroloop signal without exceeding a given degradation provided that the amplitude of the wanted Euroloop signal fluctuates periodically with a linear triangular shape between $2239 \mu\text{A/m}$ and $40 \mu\text{A/m}$ with a fundamental frequency of 25 Hz. Additionally, the receiver shall cope with unintentional amplitude modulation of at least 8 %.

The degradation limit is defined by the Bit Error Ratio $BER_{DRP} = 2.0 \times 10^{-4}$ which shall not be exceeded.

7.5.2.7 Multipath Dynamic Performance

The Multipath Dynamic Performance is a requirement for the On-board Equipment to receive a wanted modulated and dynamically distorted Euroloop signal without exceeding a given degradation.

The dynamically distorted Euroloop signal shall contain two copies of identically modulated and coded Euroloop signals that feature propagation delays of 0 ns and 500 ns. The z-component of the magnetic field strengths of these two Euroloop signals shall fluctuate periodically as specified in Figure 7-6.

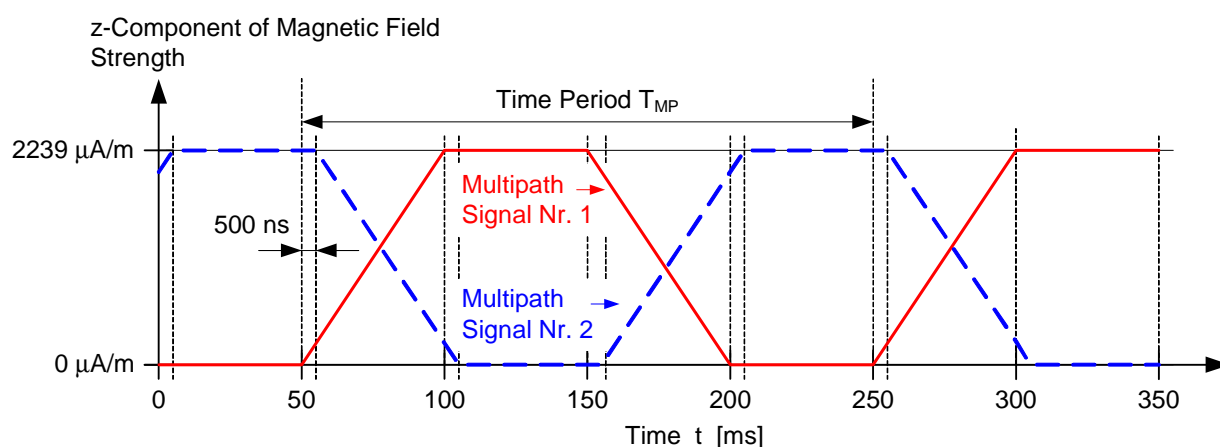

Figure 7-6: Time-Varying Multipath Signals

The degradation limit is defined by the Bit Error Ratio $BER_{DRP} = 2.0 \times 10^{-4}$ which shall not be exceeded.

7.5.2.8 Tolerable Centre Frequency Error

The centre frequency error Δf_{cmax} of the On-board Equipment is defined as the difference between the nominal centre frequency $f_c = 13.54750$ MHz of the Euroloop signal and the corresponding actual centre frequency f_{ac} of the modulated Euroloop signal at the input of the On-board Equipment.

The Tolerable Centre Frequency Error (TCFE) is a requirement for the On-board Equipment to receive a wanted Euroloop signal with the maximum allowed centre frequency error Δf_{cmax} without exceeding a given degradation.

The degradation limit is defined by the maximum allowed **$\text{BER}_{\text{TCFE}} = 2.0 \times 10^{-4}$** .

The maximum centre frequency error Δf_{cmax} shall not exceed **$\Delta f_{\text{cmax}} = f_c \pm f_c \cdot 30$ ppm**.

7.5.2.9 Tolerable Chip Rate Error

The chip rate error of the On-board Equipment is defined as the difference between the nominal chip rate R_c of the Euroloop signal and the corresponding actual chip rate R_{ac} of the modulated Euroloop signal at the input of the On-board Equipment.

The Tolerable Chip Rate Error (TCRE) is a requirement for the On-board Equipment to receive a wanted Euroloop signal with the maximum allowed chip rate error without exceeding a given degradation.

The degradation limit is defined by the maximum allowed **$\text{BER}_{\text{TCRE}} = 2.0 \times 10^{-4}$** .

The maximum Chip Rate (CR) error Δf_{CRmax} shall not exceed **$\Delta f_{\text{CRmax}} = R_c \pm R_c \cdot 70$ ppm**.

7.5.2.10 Tolerable MTIE of the Chip Rate

The tolerable MTIE of the chip rate is a requirement for the On-board Equipment to receive a wanted Euroloop signal with an MTIE according to sub-clause 6.7.4 without exceeding a given degradation.

The degradation limit is defined by the maximum allowed **$\text{BER}_{\text{TCRE}} = 2.0 \times 10^{-4}$** .



7.6 Power Supply of the On-board Equipment

The On-board Equipment shall be powered from a power supply of the vehicle. The interface for the power supply is not standardized. The power supply of the vehicle and of the On-board Equipment is assumed to comply with EN 50155 [N18].

7.7 Environmental Requirements

7.7.1 On-board Equipment

The On-board Equipment shall comply with the applicable environmental requirements of EN 50125-1 [N24] and EN 50155 [N18].

7.7.2 Environmental Conditions for the Antenna Unit Function

In case the Eurobalise antenna is used for reception of the Euroloop Up-link signal, the environmental conditions for the Antenna Unit function shall be according to SUBSET-036 [N6].

7.8 Installation Constraints for the Antenna Unit Function

If a common Antenna Unit is used for the Euroloop and Eurobalise system, the installation constraints of the Eurobalise system apply.

The Antenna Unit function shall be installed on the train to allow for

- the reception of the up-link Euroloop signal by the LTM function from Interface 'A_L1', and
- the transmission of the activation signal into the air gap Interface 'A_L4' complying with the requirements specified in sub-clause 7.3.3.

7.9 Specific Electrical Requirements

The On-board Equipment shall comply with the applicable electrical requirements of EN 50155 [N18].

7.10 Test Requirements

7.10.1 General

This sub-clause lists the test tools required to test the On-board Equipment. The specifications of these test tools are provided in the SUBSET-103 entitled “Test Specification for Euroloop” [N5].

7.10.2 Test Signals

The Test Signals for the On-board Equipment are defined in SUBSET-103 [N5].

7.10.3 Test Tools

7.10.3.1 Euroloop Reference Antenna

For interoperability reasons within the ELS, the Euroloop Reference Antenna (ERA) shall be standardised as a laboratory equivalent for the ELC in trackside environment. The ERA shall allow the transmission of the Euroloop signal and the required interfering test signals specified in sub-clause 7.10.2 within laboratory environment.

7.10.3.2 Magnetic Field Probe

Measurements of the magnetic field strength shall be performed with the Magnetic Field Probe (MFP) detailed in sub-clause 6.12.3.1.

7.11 EMC Requirements

7.11.1 Emission

7.11.1.1 Aspects Not Related to the Air Gap

The applicable EMC standard for On-board Equipment (OE) is the EN 50121-3-2 [N2].

The corresponding emission requirements are specified in clause 7 of EN 50121-3-2 [N2].

The On-board Equipment shall comply with the emission requirements stated in Table 7-1.

Table 7-1: Emission Requirements for On-board Equipment

Topic	Standard	Reference
AC or DC terminals, Signal lines	EN 50121-3-2 [N2]	Table 5
Enclosure	EN 50121-3-2 [N2]	Table 6

7.11.1.2 Aspects Related to the Air Gap

7.11.1.2.1 In-band Emission

The emission from the Euroloop On-board Equipment shall comply with EN 302 609 [N26], and the activation signal frequency mask defined in FFFIS for Eurobalise [N6].

7.11.1.2.2 Out-band Emission

The emission from the Euroloop On-board shall comply with EN 302 609 [N26].

7.11.2 Immunity

7.11.2.1 Aspects Not Related to the Air Gap

Immunity requirements for On-board Equipment (OE) are specified in EN 50121-3-2 [N2].

The On-board Equipment shall comply with the immunity requirements state in Table 7-2.

Table 7-2: Immunity Requirements for On-board Equipment

Topic	Standard	Reference
Power Ports	EN 50121-3-2 [N2]	Table 7
Signal Ports	EN 50121-3-2 [N2]	Table 8
Case	EN 50121-3-2 [N2]	Table 9

This requirement does not apply for the frequency range ± 500 kHz centred on the nominal frequency of 27.095 MHz of the activation signal.

7.11.2.2 Aspects Related to the Air Gap

7.11.2.2.1 In-band Susceptibility

The Euroloop On-board Equipment shall be able to operate compliantly with this Standard, when being exposed to the radiated noise of transient burst nature that is typically present in the air-gap during the normal train operation, due to emission from electrical traction drives, cables, and engines.

Shape of such noise bursts, time duration, and frequency distribution are among the most prominent features affecting the susceptibility characteristics of the On-board Equipment. They are strongly dependent on the type of electrification and of the electrical/electronic devices in actual use.

The noise level in the air-gap zone is generally dependent on the geometry and the position of the possible noise sources (radiating cables, reflecting surfaces, etc.), with respect to the position chosen for the Antenna Unit installation.

No harmonised standards exist to date on this kind of susceptibility issue. Therefore, each supplier of On-board Equipment shall responsibly define suitable models representing worst case susceptibility conditions and modes (with reference to the recalled ones) that may be possible within the range of application cases of his commercial interest. The definition of the noise environment and the suitability of the elaborated models are a matter of shared responsibility between suppliers of On-board Equipment, rolling stock devices, and infrastructure devices. Specific compatibility cases may be needed (to be decided on a case by case basis).

The supplier of the On-board Equipment shall then coherently prove the fulfilment of the functionality and the availability requirements for the On-board Equipment, as defined in this Norm, by adequate simulation of such worst case susceptibility conditions and modes during functional Laboratory Tests.

7.11.2.2.2 Out-band Susceptibility

Radiated immunity requirements shall comply with the applicable items of Table 9 in clause 8 of EN 50 121-3-2 [N2]. This requirement does not apply

- for the frequency range $27.095 \text{ MHz} \pm 500 \text{ kHz}$ centred on the carrier frequency of the activation signal.
- for the frequency range between DC and 36 MHz of Euroloop up-link signal.



Annex A INFORMATIVE REFERENCES

Remarks:

- References are either specific (identified by data of publication, edition number, version number, etc.) or non-specific.
- For a specific reference, subsequent revisions do not apply.
- For a non-specific reference, the latest version applies. In the case of a reference to a EN, CENELEC, IEC or ICNIRP document, a non-specific reference implicitly refers to the latest version of that document.
- See sub-clause 3.2 for normative references.

Annex B DIRECT SEQUENCE SPREAD SPECTRUM MODULATION (INFORMATIVE)

B.1 Multi Path Environment for Euroloop Subsystem

The Euroloop signal received by the Antenna Unit (AU) function is made up of replicas of the transmitted signal. These replicas have different amplitudes and delays as they reach the AU along different propagation paths. This leads to constructive and destructive interference of the signal components at the AU. Due to the frequency selectivity of this effect, narrowband signal suffer larger variations of their received signal amplitudes than their wideband signal counterparts as the destructing interference is limited to fractions of the whole signal bandwidth and therefore has only a minor influence on the transmission quality.

B.2 DSSS Principles

Direct Sequence Spread Spectrum (DSSS) modulation with Code Division Multiple Access (CDMA) scheme is used to transmit the Euroloop signal from the Trackside to the On-board Equipment.

Spread spectrum waveforms are modulated twice. Once by using traditional modulation techniques such as PSK, FSK, etc. and then, for a second time with the wideband modulation of choice, i.e., Frequency Hopping (FH), Direct Sequence (DS) or Hybrid (FHDS). The wideband modulation tends to spread the signal energy over a wide range of frequencies.

CDMA denotes a scheme to distinguish different information channels in the code domain rather than in the time (Time Division Multiple Access, TDMA) or frequency (Frequency Division Multiple Access, FDMA) domain. This is equivalent in saying that information channels are distinguished by different spreading codes rather than by time slots or frequency channels. Hence, every channel simultaneously uses the full available spectrum.

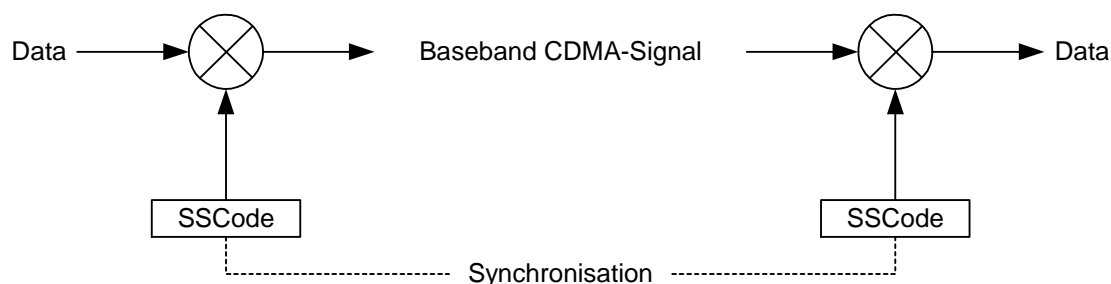

Figure B- 1: CDMA Modulator and Demodulator

B.3 Basic Transmitter Functionality

Spread Spectrum Coding

The DSSS modulator multiplies each bit of the data stream with a period of the spreading code, the SSCode, which has a length of N_c chips. This is a multiplication (binary EXNOR-operation) of two bit-streams where the SSCode has an N_c times higher bit rate than the data stream (see Figure B-1). The resulting bandwidth of the modulated signal is much wider than the bandwidth of the original data signal.

Distinction has to be made between the chip rate R_c of the spreading sequence and the data rate R_d of the binary bit stream of the data signal.

Modulation

The SSCode data signal is a base band signal. For transmission to the air gap (via Euroloop Leaky Cable) it is necessary to shift its spectrum to RF.

The base band signal for the ELS has a nominal chip rate of $R_c = 4.51583$ Mchip/s. This signal is multiplied by a Raw Carrier RC of frequency f_c , which results in a shift of the signal spectrum to this centre frequency. In the case of the ELS, the centre frequency f_c is equal to three (3) times the chip rate R_c (i.e. $f_c = 13.54750$ MHz). Then the signal is band pass filtered to attenuate signal components above the frequency $f_c + R_c$ and below the frequency $f_c - R_c$. This signal is then amplified and filtered before it is fed into the Euroloop Leaky Cable (ELC).

B.4 Basic Receiver Functionality

Demodulation and Decoding Implementation

The following part of this sub-clause provides a functional description of the DSSS demodulation in the form of a block diagram (Figure B- 2). The block diagram does not stipulate a mandatory way to realize the DSSS demodulation. Various arrangements of such a demodulator may be used to recover the transmitted signal.

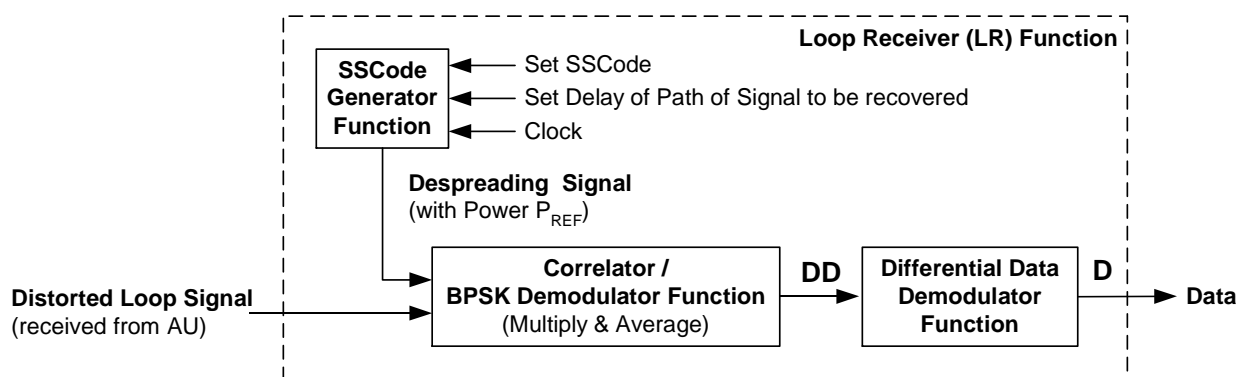

Figure B- 2: Functions Associated with Demodulation

SSCode Generator Function

The SSCode generator function provides the SSCode required to de-spread the received Loop signal, the selection of the appropriate SSCode and its delays. The delays are synchronous to the ones of the received multi-path signals. The determination of the delay values usually require an acquisition and tracking algorithm (not shown in Figure B- 2). The acquisition performs the initial search of the SSCode delay(s). The tracking maintains synchronization between the delay(s) of the received SSCode(s) and the internally generated SSCode(s).

De-spreading

De-spreading denotes the process of removing the spread spectrum code from the data stream. This is performed by multiplying each demodulated signal (see above) with the same spreading code used for the generation of the transmitted Euroloop signal. For the purpose of obtaining the originally transmitted data stream, the locally generated spreading code must be synchronous to the one of the received signal. Therefore, an acquisition and tracking circuit is required within the Loop Receiver (LR) to accomplish this task. Finally, the product of the two signals is summed up over the duration of the period of the spreading code to obtain the original data stream (see Figure B- 1).



This operation corresponds to what is commonly called a correlation process and therefore the receiver is called a correlation receiver. The reference SSCode defines the channel which the receiver is expected to receive.

The correlator/BPSK demodulator function performs two tasks. It de-spreads the received Loop signal, and removes the BPSK modulation from the Euroloop signal received at the air gap Interface 'A_L1'. The result is the Differential Data signal DD as shown in Figure 6-12 and Figure 6-13.

Demodulation

The demodulation process is performed in two steps. First the received signal is multiplied by a signal identical to the RC in the transmitter. The resulting signal is then passed through a low-pass filter to get rid of the harmonics. This well known process shifts the signal spectrum back to base band.

The differential data demodulator function recovers the serial Data stream D from the Differential Data signal DD as shown in Figure 6-12 and Figure 6-13.

B.5 Robustness against Interference

Figure B- 3 depicts signal spectra before and after the despreading process within the receiver. Three cases are distinguished:

- de-spreading of a noisy Euroloop signal,
- de-spreading of a noisy Euroloop signal in the presence of a narrowband interferer, and
- de-spreading of a noisy Euroloop signal in the presence of an other Euroloop signal.

Before Demodulation (Antenna Signal)

After Demodulation (Data Signal)

Case A: No Interferences

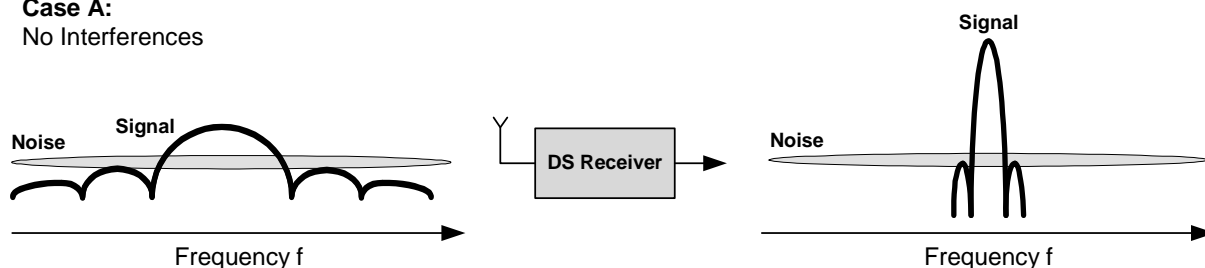

Case B: Interference of a Narrowband Signal

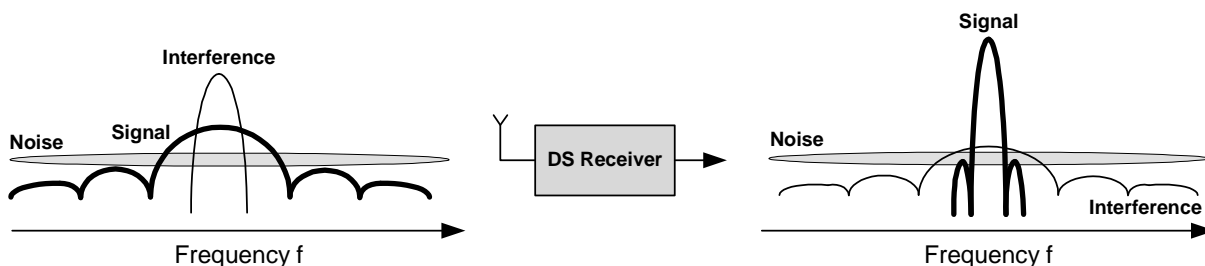

Case C: Interference of Signal B with another SSCode

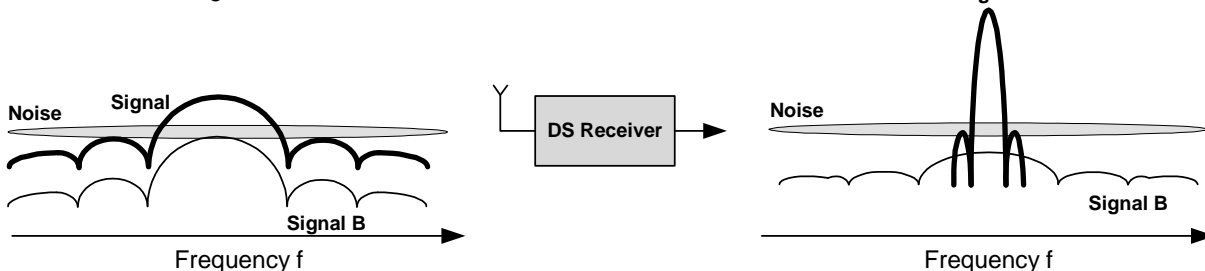

Figure B- 3: Spectral Behaviour of CDMA Signals

The left side of Figure B- 3 shows the spectrum of the received signal at the input of the AU. The right side shows the spectrum of the demodulated data signal.

Case A: Normal operation without interference of other signals

Case B: A narrowband interfering signal is present within the band of the spread spectrum signal. The DSSS demodulation spreads the power of the narrowband interfering signal over the whole receiver bandwidth while the spectrum of the wanted signal collapses to a narrow frequency range. The subsequent narrowband low-pass filter passes the whole power of the wanted signal but only a fraction of the power of the unwanted inter-

fering signal. This causes the signal-to-interference signal power to increase at the output of the correlator accordingly.

Case C: This time, the interfering signal is another DSSS signal with a different SSCode (Interfering Signal B on a different "Code"-Channel). Proper selection of the spreading codes allows keeping the cross-correlation between different spreading codes to a minimum. Accordingly the interfering DSSS signal with a different spreading code than the one used for generating the wanted signal will be very much attenuated. This feature allows sharing the RF frequency band simultaneously among different users as the distinction between the channels is based on the orthogonality of the codes rather than time or frequency slots.

B.6 Processing Gain

For a DSSS, random binary data with a rate R_d bits per sec (bps) is multiplied (e.g. realised with an EXOR Gate) by a pseudorandom binary waveform, which is at much higher rate and it provides the frequency spreading operation. This Pseudo-Noise (PN) binary source outputs symbols called chips at a constant chip rate R_c chips per sec (cps). This is a random noise like signal, and hence the name PN signal. The chip rate is always higher than the bit rate, and the ratio of the chip rate to the bit rate in dB is defined as the Processing Gain PG.

$$PG = R_c/R_d \text{ i.e., } 26.7 \text{ dB.}$$

The PG can be viewed as Signal-to-Interference Ratio (SIR) at the receiver after the de-spreading operation (removal of PN). The larger the overall bandwidth used, the higher the PG assuming a constant data rate. A higher PG implies greater immunity against interference. Direct sequence spread spectrum signals can actually operate at negative signal to interference ratios given that the processing gain is large enough.

B.7 Properties of Spreading Codes

In general, the CDMA chip sequences are assumed to be statistically independent, and identically distributed random processes, i.e. Bernoulli sequences. Thus the sequences used for the generation of spread spectrum signals should have the same key "randomness" properties as a truly random Bernoulli sequence. These key properties, the three randomness postulates of Golomb can be characterised as follows:

Balance Property: Relative frequencies of "0" and "1" are each 1/2.

Run Property: Run lengths (of zeros or ones) are as expected in a Bernoulli sequence.

Shift Property: If the random sequence is shifted by any nonzero number of elements, the resulting sequence will have an equal number of agreements and disagreements with the original sequence.

In practice, especially the short code period CDMA sequences are designed to have low time cross-correlation, so they are only quasi-orthogonal and thus the sequences in short code CDMA systems are not statistically independent. With longer code period, the CDMA sequences behave more like Bernoulli sequences. The long-code CDMA systems are in fact sometimes called (pseudo)random (R-CDMA) systems as opposed to short-code deterministic (D-CDMA) systems.

The above three properties of spreading codes are usually not met completely. The remaining amount of DC (balance property) within the spreading codes limits the dynamic range of the receiver. The degree of orthogonality (run and shift property) of the chosen spreading codes limit the co-channel rejection and by this the receiver's ability to discriminate between different Euroloop signals.

B.8 Orthogonality

Orthogonal codes have zero cross-correlation! They may seem to be attractive to replace PN codes which have non-zero cross-correlations but in practice the situation is quite different. The cross-correlation value is zero only when there is no offset between the codes. In fact, they have large cross-correlation values with different offsets, much larger than PN codes. The autocorrelation property is usually not good either. Orthogonal codes have an application in perfectly synchronized environments such as in the forward link of mobile communications.

B.9 Even and Odd Cross Correlation

The difference between even and odd cross-correlation becomes clear if one considers a spread spectrum system where a sequence is produced from a PN sequence through modulation by a data sequence. Then the odd (resp. even) cross-correlation occurs when the consequent data bits are the different (resp. the same).

B.10 Receiver Performance

Two types of unwanted signals may compromise the co-channel characteristic of the receiver:

- Insertion / cross talk of an Euroloop signal from a parallel Euroloop.
- Expected Euroloop signal with a different delay with respect to the wanted signal caused by multi-path propagation.

The processing gain and the degree of orthogonality characterise the achievable co-channel rejection between Euroloop signals transmitted in the vicinity of one another using different spreading codes. Larger PG and the better orthogonality between the spreading codes increases the co-channel rejection ratio of the receiver.

This translates into requirements for auto- and cross correlation properties within the used set of SSCodes and all pairs of SSCodes within this set:

- For each possible pair of spreading code the values of the even and odd cross correlation functions should be as low as possible for all delay offsets.
- For each SSCode itself the autocorrelation function should be as low as possible for all delay offsets, except for a delay offset zero where the value is maximum and amounts to the power of the SSCode signal.

B.11 Methods for SSCode Evaluation

Arbitrary Gold Codes

There are several possibilities to find a set of spreading codes with suitable correlation and cross correlation properties. Arbitrary Gold Codes Given a preferred pair of sequences of period $n = 2^N - 1$ where N denotes the number of stages of the shift register used to generate the code. We can construct a new family of sequences by taking the modulo-2 sum of the pair of sequences with the n cyclically shifted versions of one sequence or vice versa. Thus, we obtain n new periodic sequences with period n . If we include also the original sequences we obtain a family of $n + 2$ sequences. The resulting sequences are called Gold sequences.

The cross-correlation function for any pair of sequences in the family of Gold Sequences generated with a given preferred pair was proven by Gold to be three-valued with possible values $\{-1, -2^{(m+1)/2} - 1, 2^{(m+1)/2} - 1\}$. The gold codes from "different" Gold code groups have bad correlation properties, even when synchronised.

The rules to generate so-called Arbitrary Gold-Codes would guarantee such properties, but only for sets of codes with lengths of $2^N - 1$ ($N = \text{integer}$). Unfortunately for the ELS such lengths are not suitable. The code length was decided to be $N_c = 472$. Furthermore the inverse of each code (so-called odd code) has also to be accepted as a suitable code. This is due to the fact that modulation of a binary data bit 1 leads to the code itself and modulation of a 0 leads to the inverse code (EX-NOR-operation of data bit and code).

The rules for finding arbitrary Gold-Codes are therefore not sufficient.

A Method for finding SSCodes with good odd behaviour in addition to the other requirements is to generate different Gold-Codes and to pick a sub-set of these codes by random search within the code-set of spreading codes.

Kasami Algorithm

A similar procedure used in the generation of Gold sequences can be applied to generate a smaller set of $M = 2^{m/2}$ binary sequences of period $n = 2^m - 1$, where m is even. In this procedure, we begin with an m -sequence s and we form a binary sequence r by taking every $2^{m/2} + 1$ bit of s . In other words, the sequence r is formed by decimating s by $2^{m/2} + 1$. It can be verified that the resulting r is periodic with period $2^{m/2} - 1$. Now, by taking $n = 2^m - 1$ bits of the sequences s and r , we form a new set of sequences by adding, modulo-2, the bits from s and all $2^{m/2} - 2$ cyclic shifts of the bits from r . By including s in the set, we obtain a set of $2^{m/2}$ binary sequences of length $n = 2^m - 1$. These are called the (small set of) Kasami sequences.

The autocorrelation and cross-correlation functions of these sequences take on values from the set $\{-1, -(2^{m/2} + 1), 2^{m/2} - 1\}$. Hence, the maximum cross-correlation value R_{cc} for any pair of sequences from the set is

$$R_{cc} = 2^{m/2} + 1.$$

Genetic Algorithm

To find spreading codes with the desired length of N_c for ELSs, a large set of arbitrary spreading codes was generated and then tested for the different requirements. A genetic algorithm was used for extracting favourable spreading codes. Due to the fact, that the algorithm can evaluate the required properties, the spreading codes found by this random approach are equally well suited for the use in a DSSS-System as a Kasami-Code. But they may be designed to the required Code length.

B.12 Distortions of the Euroloop Signal in the Air Gap

Although the current in the Euroloop Leaky Cable directly transforms into magnetic field and its coupling factor hardly depends on frequency, the shape of the spectrum of the magnetic field in the air gap strongly depends on

- the propagation environment,
- the position (x) along the track,
- the spreading code of the Loop signal,
- the type of the Euroloop Leaky Cable, and
- the positioning of the Euroloop Leaky Cable along the track.

As a consequence, the spectrum of the magnetic field in the air gap is distorted. Therefore, the undistorted spectrum of the Euroloop signal can only be measured at Interface 'CA_L'.

Annex C INFLUENCE OF DEBRIS (INFORMATIVE)

C.1 Introduction

An evaluation of the influence of debris on the level budget of the Eurobalise up-link is straight forward, since both the Balise and the On-board AU are small and can thus easily be immersed, covered with dirt and so on. For the TE of the Euroloop, this is much more difficult if not impossible, due to the distributed nature of the Loop with lengths up to 1 km.

Despite this fact, margins in decibels for the influence of debris have been assumed in sub-clause 6.8.3.2. For the trackside equipment, a margin of 6 dB is foreseen between the lower limit of the magnetic field strength *at* installation and the lower limit *after* installation.

C.2 Considered Debris

The types of debris to be expected for the Euroloop TE and OE are basically the same as for the class B Eurobalise system, as specified in [N6].

Table C- 1: Debris Layers on Top of the ELC

Material	Description	Layer on Top of ELC [mm]
water	clear	100
	0.1% NaCl (weight)	10
snow	fresh, 0°C	300
	wet, 20% water	300
ice	non porous	100
ballast	stone	100
sand	dry	20
	wet	20
mud	without salt water	50
	with salt water, 0.5% NaCl (weight)	10
iron ore	hematite (Fe ₂ O ₃)	20
	magnetite (Fe ₃ O ₄)	2
iron dust	braking dust	10
coal dust	8% sulphur	10
oil and grease		50

Debris conditions for the On-board Equipment are manufacturer dependent, but some examples are given in [N6].

C.3 Measurement Results

The effect of several of the listed debris conditions have thoroughly been evaluated by CEDEX during the measurement campaign in March 2003. The measurements pertained the Eurobalise system at the frequency of 4.2 MHz (Eurobalise up-link) and 27.095 MHz (Tele-powering signal).

A subset of these measurement results are reproduced in Table C- 2 below.

Table C- 2: Effects of Debris Measured by CEDEX

Matter	Rel. Signal Level at 4.2 MHz	Rel. Signal Level at 27.095 MHz
Free Air	-34.33 dB	-19.21 dB
Clear Water	-34.31 dB	-19.48 dB
Metal Plate	-34.33 dB	-18.64 dB

The results reveal that the difference of the attenuations of among the different types of debris amount only to 0.02 dB, and 0.84 dB at the frequencies of 4.2 MHz, and 27.095 MHz, respectively.

C.4 Conclusion

The results provided in sub-clause C.3 above justify that the considered debris conditions

- have an insignificant effect on the link budget of the Euroloop system,
- and make up only a small part of the ± 6 dB margin attributed to the z-component of the magnetic field of the Euroloop signal at the reference position on the air gap Interface 'A_L1' (see sub-clause 6.8.3.2.2).

Additionally, there is a definite advantage of the Euroloop link budget regarding its sensitivity to debris, as compared to the Eurobalise system:

- The Euroloop signal is transmitted from a non-resonant (aperiodic) antenna (the Euroloop Leaky Cable (ELC)), whereas the transmit antenna of the Balise is resonant. In general, resonant antennas may be detuned by debris or close-by conducting objects to a larger extent than non-resonant antennas.

Annex D GENERAL INSTALLATION RULES (INFORMATIVE)

In order to maintain a working Loop Transmission System the magnetic field strength at the reference position in the air gap must stay within the limits stated in sub-clause 6.8.3.2. Various imperfections and non-uniformities in the surrounding of the leaky cable can result in variations of the magnetic field strength. These sources of this disturbance are for example:

- feeding point of the leaky cable,
- isolation joints along the track,
- cable crossovers,
- z-connections,
- transitions between track sections made of metal and wooden or concrete sleepers,
- wood, metal or concrete transitions under the tracks,
- variation of height of the tracks, height changes etc.,
- excursions of the cable laying with respect to the rails,
- metal bridges,
- track switches, and
- track crossings.

The above sources of disturbances can lead locally to either an increase or (more commonly) reduction of the magnetic field strength. To counteract these excursions of the magnetic field strength measures might be taken such as

- additional mounting of the clamps to improve the straight laying of the cable in the foot of the rail,
- adjust distance between leaky cable and the rail,
- mounting the Loop cable in the inner or outer foot of the rail,
- utilisation of common mode chokes at the feeding point, isolations joints, etc.,
- utilisation of a non-radiating jumper cable at isolation joints or transitions between metal, wooden or concrete sleepers, and
- utilisation of other type of leaky cable with less or more coupling.



Annex E TELEGRAM TRANSMISSION TIME (INFORMATIVE)

For the Euroloop, a short telegram with $L_S = 341$ data bits and a long telegram with $L_L = 1023$ data bit is defined in accordance with [N6].

Considering the data bit rate R_d of approx. 9567.4 bit/s, the achieved number of telegrams per second is

$$R_d / (L_S + 121 \text{ bit}) \approx 20.7 \text{ telegrams / s for short telegrams, and}$$

$$R_d / (L_L + 77 \text{ bit}) \approx 8.7 \text{ telegrams / s for long telegrams}$$

which in turn yields a minimum telegram transmission time of

$$(L_S + 121 \text{ bit}) / R_d \approx 48.3 \text{ ms for a short telegram, and}$$

$$(L_L + 77 \text{ bit}) / R_d \approx 115.0 \text{ ms for a long telegram, respectively.}$$

The required transmission time is related to both, the requirements defined by the coding strategy where $341 + 121$ bits, and $1023 + 77$ bits are needed to decode a short, and long Euroloop telegram, respectively, and also to the extra reception time needed to achieve availability. The required transmission time need be realated to avalibility as defined in sub-clause 5.4.4.2.



Annex F EUROLOOP SPREAD SPECTRUM CODES (NORMATIVE)

The SSCode length shall be $N_c = 472$ bits or chips. Euroloop shall use the 16 standardised SS Codes defined in Table F- 1. In this table one column is used for each SSCode.

An SSCode Number 0 through 15 (see top line of Table F- 1), the so-called Q_SSCODE , identifies each SSCode. The SSCode Number is identical with the variable called *Spread Spectrum Code for Euroloop* and abbreviated by Q_SSCODE of [N9]. Its value is part of the EOLM Packet transmitted by Eurobalise.

The chips of the Q_SSCODE fifteen (15) are shaded in Table F- 1 to emphasise that this SSCode shall be used *exclusively* for testing purposes. This is required to prevent accidental error indication by the On-board Equipment within a train which runs along a Loop section currently being tested with Q_SSCODE fifteen (15).

The time sequence of the SSCode chips is from top to bottom (chip no. 0 to chip no. 471).

Table F- 1: Set of Sixteen (16) Euroloop SS Codes of Length $N_c = 472$ with Associated Q_SSCODE Numbers

Chip No.	SSCode Nr. (Q_SSCODE)															
	0	1	2	3	4	5	6	7	8	9	10	11	12	13	14	15
	SSCode															
0	0	0	0	1	0	0	0	0	0	1	0	1	1	1	0	0
1	0	0	0	1	1	0	1	1	1	1	0	0	0	0	0	1
2	1	0	0	1	1	0	0	0	0	1	1	0	1	1	0	1
3	1	1	1	0	0	0	1	1	1	1	0	0	1	0	1	0
4	1	1	0	0	0	1	1	1	0	0	1	0	0	1	1	1
5	0	1	1	0	1	1	1	0	0	0	0	1	1	1	0	1
6	0	0	0	1	1	1	0	1	1	0	0	1	0	0	0	1
7	0	1	0	0	0	1	0	1	0	1	1	1	1	1	1	1
8	0	0	1	1	1	1	0	0	1	1	1	1	0	1	0	0
9	1	0	1	0	1	1	0	1	0	0	0	1	0	1	1	0
10	1	0	1	0	0	1	0	1	0	0	0	1	1	1	0	0
11	1	1	0	1	1	0	0	0	0	1	0	1	0	1	0	1
12	1	0	1	0	0	1	0	0	0	0	1	1	0	1	0	0
13	1	1	0	1	1	1	1	0	0	1	1	0	1	1	0	0
14	1	1	1	0	1	0	1	0	1	0	0	1	0	0	0	0
15	0	0	0	1	1	1	0	1	1	0	1	0	0	1	1	1
16	0	0	1	0	1	1	0	0	0	0	0	0	1	0	1	1
17	1	1	0	1	0	0	1	0	1	1	1	0	1	1	0	1
18	1	1	1	1	1	1	0	0	0	0	0	0	1	1	0	1
19	0	1	0	1	0	1	0	1	1	0	1	0	0	1	0	1
20	1	0	0	1	1	0	1	1	0	1	0	1	0	1	1	1
21	1	1	1	1	0	0	0	0	1	1	0	0	1	0	0	1
22	1	1	0	0	0	1	0	1	0	0	0	1	1	0	1	0

© This document has been developed and released by UNISIG

Chip No.	SSCode Nr. (Q_SSCODE)															
	0	1	2	3	4	5	6	7	8	9	10	11	12	13	14	15
23	0	1	1	1	0	0	1	1	1	1	0	0	1	1	1	0
24	1	0	1	0	1	1	0	0	0	0	0	0	1	1	0	0
25	1	1	1	0	0	1	1	0	1	1	0	1	0	0	0	1
26	1	1	0	1	1	1	0	1	0	1	0	0	1	1	1	1
27	1	1	1	0	1	0	0	1	1	1	1	0	1	0	1	0
28	1	0	0	0	1	0	1	1	0	0	0	0	1	0	1	1
29	0	1	0	1	1	1	0	0	0	0	0	1	0	1	1	1
30	1	1	0	0	0	0	0	0	1	1	1	0	1	0	1	1
31	0	0	0	0	1	1	0	1	0	0	1	1	1	0	0	1
32	1	0	0	0	1	0	0	0	0	0	0	0	0	0	0	0
33	0	1	1	1	0	1	1	0	0	1	0	0	1	1	1	0
34	1	1	1	1	0	1	0	0	0	0	0	0	1	0	1	0
35	0	1	0	1	1	1	1	0	0	1	1	0	0	0	1	1
36	1	0	0	1	0	1	1	0	1	1	1	1	0	0	0	1
37	1	1	1	1	1	0	0	1	0	0	1	0	1	0	1	1
38	1	0	0	1	0	1	0	0	0	1	0	1	1	0	0	1
39	1	1	0	1	1	1	1	1	0	1	0	1	1	1	1	0
40	0	1	1	0	0	1	1	0	1	1	0	1	1	0	0	1
41	1	0	0	0	1	1	1	0	1	0	0	0	0	0	1	0
42	0	0	1	1	1	1	0	0	1	0	0	1	1	0	1	0
43	0	1	1	0	0	0	0	1	0	0	1	1	1	1	1	0
44	1	1	1	1	1	0	1	1	1	1	0	1	0	1	0	1
45	1	0	1	1	1	1	1	0	1	0	1	0	0	0	1	1
46	0	1	1	0	0	1	0	1	1	1	1	1	1	0	0	0
47	0	1	0	0	1	1	1	1	1	1	0	0	1	0	0	1
48	0	0	0	0	1	1	0	1	1	1	0	1	0	0	0	1
49	0	1	1	1	0	0	1	1	1	1	0	1	0	0	0	0
50	0	0	1	0	1	0	0	0	0	0	1	0	1	0	1	0
51	0	0	1	1	1	1	1	1	0	0	0	0	1	1	1	1
52	1	1	0	0	1	0	0	1	0	1	1	1	0	0	1	1
53	0	0	1	1	1	0	1	0	0	1	1	1	0	1	1	1
54	1	1	1	1	0	0	0	1	0	0	0	0	0	0	1	1
55	0	0	0	1	0	1	0	0	1	1	1	1	1	1	0	1
56	0	1	1	1	0	0	0	0	0	0	1	1	0	0	0	1
57	1	1	1	0	0	1	0	0	0	1	1	0	0	0	1	0
58	1	1	1	0	0	0	1	1	1	1	1	0	0	0	0	1
59	1	0	0	1	0	0	1	0	1	1	1	0	1	1	1	1
60	0	1	1	0	0	1	1	0	1	0	0	0	1	0	0	1
61	1	0	1	1	0	1	1	1	1	1	1	0	0	0	0	1
62	1	1	0	1	0	0	1	1	0	0	0	1	1	0	1	1
63	0	0	0	1	1	0	1	0	0	1	0	1	0	0	0	0

Chip No.	SSCode Nr. (Q_SSCODE)															
	0	1	2	3	4	5	6	7	8	9	10	11	12	13	14	15
64	1	0	0	0	1	0	1	0	1	0	0	0	1	1	1	0
65	0	0	0	0	1	0	0	0	0	1	1	0	1	0	0	1
66	1	0	0	1	0	1	0	1	1	1	0	1	1	1	1	0
67	0	1	1	0	0	1	0	1	0	0	1	0	0	0	0	1
68	1	1	1	0	0	0	1	0	0	0	1	1	0	1	0	1
69	0	0	1	1	1	0	0	1	0	0	1	1	1	1	0	0
70	1	0	0	0	0	1	1	1	0	1	1	0	0	0	0	0
71	0	1	0	0	1	0	0	1	1	0	1	1	1	1	1	1
72	1	1	1	1	1	0	1	1	1	0	0	1	0	1	1	1
73	0	0	1	0	0	1	1	0	1	1	1	0	0	1	1	0
74	1	0	1	0	1	1	1	0	0	1	0	0	0	0	1	1
75	1	1	0	1	0	1	0	1	0	1	1	0	1	0	1	1
76	0	0	1	0	0	1	1	0	1	0	0	0	1	0	1	0
77	0	1	1	1	1	0	0	1	1	1	1	1	1	0	0	1
78	0	1	1	0	1	1	1	0	1	0	0	0	1	0	0	0
79	0	0	1	0	1	1	0	1	1	0	1	0	1	0	0	0
80	1	0	1	0	0	0	1	1	1	0	1	1	0	0	1	1
81	1	0	0	0	1	0	0	0	1	0	0	0	1	1	1	1
82	1	0	1	1	1	0	0	1	0	1	1	1	0	0	1	0
83	1	1	1	1	1	0	1	0	1	0	1	1	0	1	1	1
84	1	0	0	0	0	0	0	1	1	0	0	0	1	1	1	0
85	1	0	0	0	1	0	1	1	0	0	0	0	0	1	1	1
86	1	0	1	1	1	0	1	1	1	1	0	1	0	0	0	0
87	1	1	0	0	1	1	1	0	1	0	1	0	0	1	1	1
88	1	1	0	1	0	0	0	1	0	1	1	1	1	0	0	1
89	0	1	1	0	0	0	1	1	1	1	0	0	0	1	0	1
90	0	1	1	0	1	1	1	1	0	1	0	1	0	1	0	1
91	1	1	1	0	1	1	0	1	0	1	1	1	1	1	0	1
92	0	0	0	0	1	1	1	1	1	0	0	0	0	1	1	0
93	0	0	1	0	0	0	1	0	0	0	1	1	0	0	1	1
94	1	0	1	0	0	0	0	0	0	1	0	0	0	1	1	0
95	0	0	0	1	0	1	0	1	0	0	0	0	1	0	0	0
96	0	1	0	0	1	1	0	0	0	1	1	1	0	0	1	0
97	1	1	1	1	0	1	0	1	1	1	0	1	0	1	1	0
98	1	1	1	0	0	1	1	0	1	0	1	0	1	0	0	0
99	0	0	1	1	1	0	1	0	1	0	1	0	0	0	1	0
100	0	1	0	0	1	1	1	0	0	1	0	0	0	0	0	0
101	1	0	1	1	1	0	0	1	0	1	0	1	1	0	1	0
102	0	1	0	1	1	0	0	0	1	0	0	0	0	1	0	0
103	0	1	1	1	0	1	0	0	0	0	0	1	0	0	1	1
104	1	1	1	0	1	1	0	1	0	1	0	0	1	1	0	0

Chip No.	SSCode Nr. (Q_SSCODE)															
	0	1	2	3	4	5	6	7	8	9	10	11	12	13	14	15
105	1	1	1	0	1	1	1	1	0	1	1	0	1	0	0	0
106	0	1	0	1	1	1	0	0	0	1	0	0	0	0	0	0
107	1	0	0	0	1	0	0	1	0	1	0	1	1	1	0	1
108	0	1	1	0	1	1	0	0	0	1	0	0	0	0	0	0
109	0	1	0	0	1	1	1	1	0	1	0	0	1	0	1	1
110	1	1	1	0	1	1	0	1	0	0	1	1	1	1	1	1
111	1	0	1	0	1	0	0	1	0	1	0	1	0	0	1	0
112	1	0	0	0	0	0	0	1	0	1	1	0	0	1	0	0
113	1	0	1	0	0	0	0	0	1	1	1	1	0	1	0	1
114	0	1	0	0	1	1	0	1	1	1	0	0	1	1	1	0
115	1	1	1	0	1	0	1	1	0	1	1	0	1	1	1	1
116	1	0	0	0	1	0	1	1	0	0	1	0	1	1	1	1
117	1	1	0	0	1	1	0	1	0	0	0	1	0	0	0	0
118	0	0	1	1	0	1	1	0	0	0	1	0	1	1	1	1
119	1	1	1	0	0	0	1	0	0	0	0	0	0	0	1	0
120	0	0	0	1	1	0	1	0	0	1	1	1	0	0	1	0
121	0	1	0	0	0	0	0	1	1	1	0	1	1	1	1	1
122	1	0	1	1	0	0	1	0	0	0	1	0	1	0	1	1
123	0	0	0	1	0	0	0	1	0	1	1	0	0	0	1	0
124	1	0	0	0	1	1	1	0	0	0	1	0	0	1	1	1
125	0	1	0	0	0	0	0	0	1	1	1	1	0	0	1	0
126	0	1	0	1	1	0	0	0	1	1	1	1	1	1	0	1
127	0	0	1	1	1	1	1	0	1	1	0	1	0	0	0	1
128	0	1	0	1	0	0	1	0	0	0	1	0	1	1	0	1
129	0	0	1	1	0	1	1	0	1	1	0	1	0	1	0	1
130	0	0	1	1	0	0	1	0	1	1	0	0	0	1	0	1
131	1	0	0	1	0	1	0	0	0	1	1	1	1	1	0	1
132	1	1	0	0	0	1	1	0	1	1	0	0	1	0	0	1
133	0	1	0	1	0	1	0	1	1	0	1	1	0	0	0	1
134	0	1	0	1	1	1	0	0	1	0	0	1	0	1	0	1
135	0	1	1	1	0	1	1	0	1	1	0	1	1	1	1	0
136	1	0	0	1	0	0	0	1	0	0	0	1	0	1	0	1
137	1	1	0	1	1	0	0	0	1	0	0	1	1	1	0	1
138	0	0	1	1	0	1	1	1	1	1	1	0	1	0	0	0
139	1	0	1	1	1	0	1	0	1	0	1	1	1	1	1	1
140	0	1	1	1	1	1	0	1	1	0	0	0	0	1	1	0
141	1	0	1	0	0	1	0	0	1	1	0	0	0	0	0	1
142	1	1	1	1	0	1	1	1	1	1	1	1	1	1	0	1
143	0	0	0	0	0	0	1	0	1	0	0	0	0	1	1	0
144	0	1	1	0	0	1	0	1	0	1	1	0	0	1	0	0
145	1	1	0	1	1	1	1	0	0	0	0	1	1	1	1	0

Chip No.	SSCode Nr. (Q_SSCODE)															
	0	1	2	3	4	5	6	7	8	9	10	11	12	13	14	15
146	0	0	1	0	0	0	1	1	0	1	0	1	1	0	1	0
147	1	0	0	1	0	1	0	0	1	0	0	1	1	0	0	0
148	0	0	1	1	0	1	1	0	0	0	0	1	1	1	0	0
149	1	1	1	1	0	0	0	0	1	0	1	0	1	0	0	0
150	0	0	0	1	0	0	1	0	0	0	0	0	0	0	0	1
151	1	0	0	1	1	1	1	1	0	0	1	0	0	1	1	0
152	1	0	0	0	1	1	0	1	1	1	0	1	0	0	1	1
153	1	1	0	0	1	1	0	1	1	0	0	0	1	1	0	1
154	0	0	0	1	0	1	0	1	1	0	0	0	1	1	0	0
155	0	0	1	1	0	0	0	0	1	0	1	0	0	0	0	0
156	1	1	1	1	1	0	1	0	1	1	0	1	0	0	0	1
157	1	0	1	1	1	1	1	1	1	1	1	1	0	1	0	0
158	1	1	0	1	0	1	0	1	0	0	0	0	0	1	0	0
159	0	1	0	0	1	0	1	1	1	1	0	1	0	0	0	0
160	0	1	1	0	0	0	0	1	1	0	0	0	1	0	1	0
161	1	1	0	0	1	0	1	0	1	1	0	0	1	1	0	0
162	1	1	1	0	1	1	1	1	1	0	1	0	1	1	0	0
163	1	1	0	1	0	1	1	1	0	1	0	1	0	0	1	0
164	0	0	0	1	0	0	1	0	0	1	0	0	0	0	1	1
165	0	0	0	1	0	1	0	0	0	0	1	0	0	0	0	0
166	0	0	0	0	0	1	0	1	0	0	1	1	1	1	1	0
167	1	0	1	0	0	0	1	1	0	1	1	1	1	1	1	0
168	0	0	0	1	1	0	0	1	0	1	0	1	1	1	1	0
169	0	1	1	0	1	1	1	0	1	1	1	1	1	0	1	0
170	1	1	0	0	1	0	0	0	0	1	1	1	0	1	1	0
171	1	1	0	1	1	0	0	0	0	1	1	0	1	0	1	1
172	0	1	0	0	0	0	1	0	0	1	0	0	1	1	0	1
173	0	1	0	1	0	1	0	0	0	0	1	1	1	1	1	1
174	0	0	1	0	1	0	0	0	0	1	1	1	0	1	0	1
175	0	0	1	0	0	1	1	1	1	0	0	1	0	0	1	1
176	0	1	1	0	0	0	1	0	1	0	1	1	1	1	0	1
177	0	1	0	1	0	0	0	0	1	1	1	0	1	1	1	0
178	0	0	0	0	1	1	0	1	0	1	1	0	0	0	1	0
179	0	0	1	1	0	1	1	1	0	1	0	1	1	0	1	1
180	0	1	1	1	0	1	0	1	0	1	1	0	0	1	0	0
181	0	1	1	0	0	1	1	0	0	0	0	0	1	0	1	0
182	1	1	1	1	0	1	1	1	1	1	0	1	1	1	0	1
183	1	0	0	0	1	0	1	1	0	0	1	0	1	0	1	1
184	1	0	1	0	1	1	0	1	1	0	1	1	0	1	1	1
185	1	1	1	0	0	0	0	0	0	1	1	1	1	0	0	1
186	0	1	1	0	1	0	1	0	0	0	0	0	0	0	0	0

Chip No.	SSCode Nr. (Q_SSCODE)															
	0	1	2	3	4	5	6	7	8	9	10	11	12	13	14	15
187	0	1	1	0	1	1	0	0	0	0	0	1	1	0	1	1
188	0	1	1	1	1	0	1	0	0	0	0	0	1	1	0	1
189	0	0	0	1	0	0	1	0	0	1	1	1	1	0	0	1
190	0	0	1	0	0	0	1	0	0	0	0	1	0	0	1	0
191	0	1	0	1	0	0	1	1	1	1	0	1	1	0	0	0
192	0	1	0	1	1	0	0	1	0	1	0	0	1	1	0	0
193	1	1	0	1	0	0	1	1	1	0	1	1	1	0	0	0
194	1	1	1	0	0	0	0	0	1	0	1	1	1	0	0	1
195	1	1	0	0	0	0	0	1	0	0	0	1	0	0	1	0
196	1	0	1	0	0	1	0	1	1	1	1	0	1	1	1	0
197	1	1	1	1	0	0	1	0	1	1	1	0	1	0	1	0
198	0	1	0	0	0	1	1	0	0	0	0	1	0	0	0	1
199	1	1	1	0	0	1	0	1	0	0	1	0	1	0	1	1
200	1	1	0	1	0	1	0	1	0	0	0	0	0	0	0	0
201	1	1	1	0	1	0	0	0	0	0	0	0	1	1	0	1
202	0	1	0	1	1	0	1	0	0	1	0	1	0	1	0	1
203	1	0	1	1	1	1	0	0	1	1	1	0	1	0	1	1
204	0	0	0	0	0	1	1	1	0	1	0	1	0	1	1	1
205	0	0	0	1	1	1	1	1	1	0	1	1	0	0	1	0
206	0	0	0	1	1	0	0	0	0	1	1	0	0	1	1	0
207	0	0	0	1	1	0	0	1	1	1	0	1	0	1	1	0
208	1	1	1	0	1	1	1	0	0	1	0	1	0	0	0	1
209	0	1	1	0	1	0	1	0	0	0	0	0	1	0	0	1
210	0	0	0	0	1	0	0	0	1	0	1	0	0	0	0	0
211	0	1	1	0	1	1	1	0	1	1	0	1	1	1	0	0
212	0	0	0	1	0	1	0	0	0	1	1	1	0	0	0	0
213	1	0	1	0	0	0	0	1	1	1	0	1	1	0	1	0
214	1	0	0	0	0	0	1	0	1	1	0	0	0	1	0	1
215	1	0	0	0	0	0	1	0	0	0	0	1	0	1	1	0
216	1	1	0	0	0	0	0	0	0	1	1	0	0	0	0	0
217	1	0	0	0	1	0	0	1	1	0	0	0	1	0	1	1
218	0	1	1	1	1	0	1	1	1	1	0	1	1	1	1	0
219	0	0	1	1	0	0	0	0	1	0	0	1	0	1	0	1
220	1	0	1	0	1	0	0	1	1	0	0	1	0	1	1	1
221	0	0	0	1	1	0	1	1	1	1	1	0	1	0	1	1
222	1	1	0	1	1	0	1	0	0	1	0	1	0	1	1	1
223	1	0	0	1	0	0	1	1	0	1	1	1	1	1	0	0
224	0	1	1	1	0	0	1	0	0	1	1	1	1	1	1	0
225	0	1	1	1	1	1	1	1	1	1	1	0	1	1	1	0
226	1	0	1	0	1	1	1	0	0	0	0	1	1	0	0	0
227	1	0	0	0	0	1	0	0	0	0	1	1	1	0	0	0

Chip No.	SSCode Nr. (Q_SSCODE)															
	0	1	2	3	4	5	6	7	8	9	10	11	12	13	14	15
228	1	1	1	0	0	0	0	0	0	1	0	0	0	1	0	1
229	1	0	1	0	1	0	0	0	0	0	0	0	1	1	1	1
230	1	1	0	0	1	0	0	1	0	0	1	1	1	0	1	0
231	0	0	1	1	1	0	0	1	1	0	1	1	1	0	1	1
232	0	1	0	1	0	1	0	1	1	1	1	0	1	1	0	1
233	1	1	1	1	0	1	0	0	0	0	0	0	1	0	0	0
234	0	0	1	1	1	1	0	0	0	1	0	1	0	0	1	1
235	1	0	0	1	1	0	1	0	1	0	1	0	1	0	0	1
236	0	1	1	1	0	0	1	0	0	1	1	0	0	1	0	0
237	1	0	0	1	0	0	1	0	0	1	1	1	0	1	0	1
238	1	1	1	0	0	1	1	1	1	1	0	1	0	1	0	0
239	1	0	1	0	1	0	0	1	0	0	0	1	0	0	0	0
240	0	0	1	1	0	1	1	0	0	1	0	0	1	1	0	1
241	0	1	1	1	1	1	0	0	1	0	1	0	0	0	0	0
242	1	0	1	1	0	1	1	0	1	0	0	1	1	1	1	1
243	0	0	1	1	1	1	0	1	1	1	0	1	1	1	0	1
244	0	0	0	0	1	0	0	0	0	1	1	0	0	0	0	0
245	1	0	1	0	1	1	1	0	0	1	1	0	1	1	1	0
246	1	0	1	1	0	0	0	0	0	1	1	0	0	0	1	0
247	0	0	1	0	0	0	1	1	1	1	0	0	0	0	0	0
248	1	0	1	1	0	1	0	0	1	0	1	1	0	0	0	1
249	0	1	0	0	1	1	1	1	1	1	0	0	1	0	1	1
250	0	0	1	0	1	1	0	0	1	1	0	1	0	1	0	0
251	0	1	0	1	1	1	1	1	0	0	0	0	1	0	1	0
252	1	1	1	1	1	0	0	1	1	0	0	0	0	1	1	0
253	0	1	1	1	1	0	1	0	0	1	1	0	1	1	0	1
254	0	1	1	1	0	0	0	1	0	0	1	0	1	0	1	0
255	0	0	1	1	0	1	0	1	1	1	1	0	0	1	1	1
256	1	0	0	1	1	0	0	1	1	1	1	0	0	1	1	0
257	0	1	1	0	1	0	0	1	0	0	0	1	0	1	0	0
258	1	0	0	1	1	0	1	0	1	1	1	0	0	1	1	0
259	1	1	0	1	1	0	0	0	0	0	0	0	0	1	0	1
260	1	0	0	1	0	0	1	1	0	1	1	1	1	1	1	1
261	0	0	1	1	0	0	0	0	1	0	0	0	1	0	1	1
262	0	0	1	1	1	0	0	1	0	1	1	1	1	1	1	0
263	0	0	0	1	1	1	1	1	1	0	1	1	0	1	1	0
264	0	0	1	0	0	0	1	0	0	1	1	1	1	0	0	1
265	0	1	1	1	1	1	0	0	1	0	1	1	1	0	1	0
266	1	1	1	0	0	1	0	1	1	0	1	0	0	1	1	1
267	0	0	0	1	1	1	0	0	0	1	1	0	0	0	0	0
268	1	0	1	1	0	0	0	1	0	0	1	1	0	1	0	1

Chip No.	SSCode Nr. (Q_SSCODE)															
	0	1	2	3	4	5	6	7	8	9	10	11	12	13	14	15
269	0	0	0	0	0	0	1	1	1	0	1	0	1	0	0	0
270	0	1	1	0	1	0	1	1	1	0	1	1	1	0	1	0
271	0	0	1	1	0	1	1	0	1	0	1	0	0	0	1	0
272	0	0	0	1	1	1	0	0	0	0	0	0	1	0	1	1
273	0	0	1	1	1	1	0	0	0	0	1	0	1	1	0	1
274	0	1	0	0	1	1	0	1	0	1	1	0	0	0	0	1
275	1	1	1	1	0	0	1	0	0	0	1	1	1	0	1	1
276	1	0	0	1	0	0	1	0	1	1	0	1	0	1	1	0
277	0	0	1	1	0	0	1	1	1	0	0	1	0	0	1	0
278	0	1	0	1	1	1	1	0	1	0	0	0	1	1	0	1
279	0	0	0	1	0	1	1	1	1	0	0	1	0	0	1	1
280	0	1	1	0	1	1	0	1	1	0	0	1	1	1	0	0
281	1	1	0	0	0	0	0	1	0	0	1	1	0	0	0	0
282	1	0	1	1	1	0	0	0	0	0	1	0	1	0	1	1
283	1	1	1	1	0	1	1	0	1	0	0	0	1	1	0	1
284	1	1	0	1	1	0	1	1	1	1	0	0	0	0	1	0
285	1	1	1	0	0	1	0	1	1	1	1	1	1	1	0	0
286	0	0	1	0	1	1	0	1	0	1	1	1	0	0	0	1
287	1	1	1	1	1	1	1	1	1	1	1	0	0	0	1	0
288	1	1	1	1	0	0	1	0	1	1	1	0	0	1	1	0
289	1	0	0	0	0	0	1	1	1	1	0	0	0	1	1	0
290	0	1	0	1	1	1	0	1	0	1	1	1	0	1	0	0
291	0	0	1	1	0	0	0	0	0	1	1	0	0	0	0	1
292	1	1	0	0	1	0	0	0	0	0	0	1	1	1	1	1
293	0	0	1	0	1	0	1	1	0	1	0	1	1	0	1	0
294	1	0	0	0	1	0	0	1	1	0	0	0	0	1	1	1
295	0	1	0	1	1	1	0	1	1	0	0	0	1	0	1	0
296	1	0	0	1	0	0	0	0	0	0	0	0	1	0	1	1
297	1	0	1	1	1	1	1	0	1	1	1	1	1	1	1	1
298	1	1	1	1	1	1	0	1	0	1	0	1	1	1	0	0
299	1	0	0	0	0	0	0	0	1	0	1	0	0	0	1	1
300	0	1	1	1	0	0	0	1	1	1	0	0	1	1	0	1
301	1	1	0	1	0	0	0	1	1	1	1	1	0	1	0	1
302	1	1	0	1	1	1	1	0	1	0	0	1	0	0	1	0
303	1	1	1	1	1	0	0	1	1	1	0	1	0	0	1	1
304	1	0	0	1	0	0	0	1	0	1	0	0	1	0	1	0
305	1	0	0	0	0	1	1	1	0	1	1	0	0	1	1	1
306	0	1	1	0	1	1	0	0	0	1	0	0	0	1	1	0
307	1	1	0	1	0	1	0	0	0	1	0	0	0	0	1	0
308	1	1	1	0	0	0	0	0	0	0	1	0	1	0	0	1
309	1	1	0	0	1	0	0	1	0	0	0	1	0	1	1	1

Chip No.	SSCode Nr. (Q_SSCODE)															
	0	1	2	3	4	5	6	7	8	9	10	11	12	13	14	15
310	1	0	0	1	0	1	1	1	0	0	0	1	1	0	0	0
311	1	1	0	0	0	1	0	0	1	1	1	1	1	1	0	0
312	0	1	0	1	1	1	0	1	0	0	1	1	1	1	0	0
313	1	1	0	1	1	1	0	0	1	0	0	0	1	0	0	1
314	1	0	1	1	1	0	0	1	1	1	0	0	1	1	0	1
315	1	1	0	0	0	0	1	1	1	1	1	0	1	1	0	1
316	1	0	1	1	0	0	1	1	1	0	1	0	0	1	0	1
317	1	1	0	1	0	1	1	1	0	0	0	1	0	1	0	1
318	1	1	1	1	0	0	0	1	1	0	1	1	1	0	1	1
319	1	1	0	1	1	1	1	1	1	0	1	1	0	1	0	0
320	0	1	0	0	0	1	1	0	1	0	0	1	1	1	1	1
321	0	0	0	0	0	1	0	1	0	1	1	0	0	1	0	0
322	1	0	0	1	0	1	0	1	0	0	1	1	1	0	0	1
323	0	1	1	1	0	1	1	0	1	0	0	0	0	1	0	0
324	1	1	0	1	0	0	0	1	1	1	1	1	0	0	0	1
325	0	1	0	0	0	1	1	1	1	1	0	0	0	0	1	0
326	1	1	0	1	1	1	1	1	0	0	0	0	1	1	0	1
327	1	0	0	0	1	1	0	0	1	1	1	1	0	1	1	1
328	1	0	1	1	1	0	0	1	1	0	0	0	0	0	1	0
329	1	1	1	1	1	1	0	0	1	0	0	0	1	1	0	0
330	0	0	0	1	1	1	0	0	0	1	0	0	1	1	1	1
331	0	0	0	0	0	0	0	1	0	1	1	0	1	0	0	1
332	1	0	0	1	0	0	1	1	0	0	0	0	0	0	1	0
333	0	0	0	1	1	0	1	1	0	0	1	0	0	0	0	1
334	1	1	1	0	1	1	0	1	0	1	0	0	1	1	0	1
335	0	1	1	0	1	0	1	0	0	0	1	1	1	1	1	1
336	0	1	0	1	1	1	0	1	0	0	1	0	1	0	1	1
337	0	1	1	0	1	0	0	1	0	1	0	0	1	1	1	1
338	1	1	0	0	0	1	0	0	0	0	1	1	1	1	0	1
339	0	0	1	0	1	0	1	0	1	1	0	1	0	1	0	0
340	0	1	1	0	0	1	0	1	0	1	1	0	0	0	1	0
341	0	0	1	1	1	1	1	1	1	1	1	1	1	1	0	1
342	0	0	0	1	1	1	1	0	0	1	0	0	1	0	1	1
343	0	0	0	0	0	0	1	1	1	0	0	0	1	1	0	1
344	1	1	0	0	0	1	1	0	0	1	0	1	0	0	1	0
345	0	1	0	1	0	1	0	1	0	1	1	0	0	1	1	0
346	1	1	1	0	1	0	0	0	0	0	0	1	0	0	0	0
347	1	0	0	0	0	1	0	1	1	0	1	1	0	1	0	0
348	1	0	0	1	0	0	1	0	1	0	1	1	1	1	1	1
349	0	0	1	0	1	0	1	1	0	0	0	0	1	1	0	1
350	1	0	1	1	0	0	0	1	1	1	0	0	0	1	1	0

Chip No.	SSCode Nr. (Q_SSCODE)															
	0	1	2	3	4	5	6	7	8	9	10	11	12	13	14	15
351	0	1	0	0	0	1	1	0	0	1	0	0	0	1	1	1
352	0	0	0	1	1	1	1	0	1	0	1	1	1	1	1	1
353	0	1	0	0	0	1	0	1	0	1	1	1	0	0	0	1
354	1	0	1	1	1	1	1	0	0	1	1	1	0	0	0	0
355	0	1	0	1	1	0	0	1	1	1	0	0	1	1	0	1
356	0	0	0	1	1	0	1	1	1	1	0	1	0	1	0	0
357	1	1	0	1	0	1	0	0	0	0	1	1	1	0	1	0
358	1	0	0	0	1	1	1	1	1	1	1	0	1	1	1	1
359	0	1	0	0	0	0	0	1	0	0	0	0	1	0	0	0
360	1	1	1	0	1	1	0	1	1	0	0	1	0	1	0	1
361	1	1	0	0	1	1	1	1	1	1	0	0	0	1	0	0
362	0	1	1	0	0	1	1	1	0	0	1	1	1	0	0	1
363	0	1	0	1	1	1	0	0	1	1	1	1	1	1	0	1
364	0	0	0	1	1	0	0	0	0	1	1	1	0	1	0	0
365	0	1	1	1	1	0	1	1	0	0	0	0	1	1	1	1
366	0	1	1	0	1	1	1	0	1	0	1	1	1	0	1	0
367	0	0	1	1	1	1	0	0	0	0	0	0	0	1	1	0
368	1	1	1	1	1	1	1	1	1	1	0	1	0	1	1	0
369	1	0	0	0	1	0	0	0	1	0	0	0	0	0	0	1
370	0	1	0	1	0	1	0	1	0	0	0	0	1	0	1	0
371	0	1	0	1	1	0	0	1	0	0	0	1	1	0	1	0
372	1	0	1	0	1	1	1	0	0	1	0	1	0	1	1	1
373	1	1	1	0	0	0	0	1	1	1	1	0	1	1	1	1
374	1	1	0	0	1	0	1	0	1	0	1	1	1	1	1	1
375	0	0	0	1	1	1	1	0	0	0	1	1	0	1	1	1
376	1	0	0	0	0	1	0	0	0	0	1	0	0	0	1	0
377	1	0	0	0	1	1	0	1	0	0	1	1	0	1	1	0
378	1	0	0	0	0	1	0	1	1	0	0	1	1	1	1	1
379	0	0	0	1	1	1	0	0	1	1	0	0	1	1	1	0
380	1	0	0	1	1	1	1	0	1	0	0	1	1	1	1	0
381	0	0	0	0	1	0	1	0	0	0	0	1	1	1	1	0
382	0	1	1	0	1	0	1	1	1	0	0	1	0	1	1	1
383	0	1	1	0	0	0	0	0	1	1	1	0	1	0	1	0
384	1	1	1	1	1	0	1	1	0	0	1	1	0	1	1	0
385	1	1	0	1	0	0	0	1	1	1	0	1	0	1	1	0
386	0	1	0	0	0	1	0	0	0	1	1	0	1	0	1	1
387	0	0	0	1	1	0	0	1	0	1	1	0	1	0	0	0
388	0	1	0	1	0	0	1	0	1	1	0	1	0	1	1	0
389	0	1	0	1	1	0	0	1	0	1	0	0	1	0	1	0
390	0	1	0	0	0	1	1	0	1	1	1	1	1	1	1	1
391	1	1	0	0	1	1	0	1	0	0	0	1	1	1	1	1

Chip No.	SSCode Nr. (Q_SSCODE)															
	0	1	2	3	4	5	6	7	8	9	10	11	12	13	14	15
392	0	0	0	1	1	1	1	1	0	0	0	1	0	0	0	0
393	1	0	0	1	1	1	0	1	1	0	1	0	1	0	1	1
394	1	1	0	1	0	1	1	1	0	0	0	1	0	1	0	1
395	0	0	0	0	1	0	0	0	1	1	1	0	0	0	1	1
396	0	0	1	0	0	1	0	0	0	0	0	1	0	1	1	1
397	0	1	1	1	0	1	0	0	0	0	1	1	0	1	0	0
398	0	1	0	1	0	1	0	0	1	1	1	0	1	0	1	1
399	1	1	1	0	1	0	1	1	0	0	0	0	0	1	1	0
400	1	1	0	1	0	0	0	1	0	0	1	1	0	0	1	0
401	1	0	0	0	0	1	1	1	1	1	0	1	0	0	1	0
402	1	0	1	1	1	1	0	0	1	1	1	1	1	0	1	1
403	0	0	1	1	0	1	1	1	1	1	1	1	0	1	1	1
404	1	1	0	1	1	0	1	1	0	1	1	1	1	0	0	0
405	0	0	0	1	1	0	1	0	1	0	0	1	0	1	1	0
406	1	1	1	0	0	1	0	0	0	1	0	0	0	0	1	1
407	0	0	1	1	1	1	1	0	0	1	0	1	1	1	1	1
408	0	0	0	0	0	0	0	0	0	1	1	1	1	1	0	0
409	0	1	1	0	0	0	0	0	1	0	0	1	1	0	0	1
410	1	0	1	1	0	0	1	0	1	1	1	0	0	0	0	1
411	1	0	0	1	0	0	0	1	1	1	1	0	1	0	1	0
412	1	0	0	0	1	1	1	1	0	0	1	1	0	0	1	0
413	0	0	1	0	1	1	0	0	0	1	1	1	0	0	0	1
414	0	1	1	1	0	1	1	0	0	1	1	1	0	1	1	1
415	0	1	0	0	0	1	1	0	0	1	0	1	1	1	0	0
416	1	0	1	1	0	0	0	0	1	1	0	0	1	0	0	1
417	1	1	1	0	0	1	0	1	0	0	1	1	0	1	0	0
418	1	1	1	1	1	0	0	1	0	1	1	0	1	0	1	0
419	0	1	0	0	1	1	1	1	0	1	1	1	1	1	0	1
420	1	1	1	0	0	0	0	0	1	0	0	1	1	1	0	1
421	0	1	1	0	0	1	1	1	1	1	1	0	1	0	0	0
422	1	0	1	0	1	1	0	1	1	1	1	1	1	1	0	1
423	0	1	1	0	0	0	1	1	0	1	0	1	1	1	0	1
424	0	1	0	0	1	1	1	1	0	1	0	0	0	1	1	1
425	0	0	1	1	0	0	0	0	1	0	1	0	0	1	1	0
426	1	1	1	0	0	0	0	1	1	1	1	0	1	1	1	0
427	1	1	1	0	1	0	1	0	0	1	1	0	0	1	1	1
428	1	0	1	1	1	0	0	0	0	0	0	0	1	1	0	1
429	0	0	0	1	0	1	1	1	1	1	0	0	0	1	0	0
430	1	1	1	1	0	0	1	0	0	0	1	1	1	1	1	0
431	0	1	0	0	1	1	0	1	1	1	0	0	0	0	0	1
432	0	0	1	0	1	0	1	0	1	0	0	0	1	1	0	0

Chip No.	SSCode Nr. (Q_SSCODE)															
	0	1	2	3	4	5	6	7	8	9	10	11	12	13	14	15
433	1	0	0	0	1	1	0	0	0	0	1	0	0	1	1	0
434	0	0	1	0	1	0	0	0	1	0	0	0	0	0	1	0
435	0	1	1	0	0	1	1	0	0	0	0	0	1	1	0	1
436	1	0	0	0	1	0	0	1	1	1	0	0	0	1	0	0
437	1	0	0	0	0	1	0	1	1	0	0	0	0	1	1	1
438	1	1	0	0	0	0	1	1	1	1	0	1	1	1	1	1
439	1	1	1	0	0	1	1	1	1	0	1	0	0	1	1	0
440	0	0	1	0	1	1	0	0	1	0	0	1	0	1	0	1
441	1	0	0	0	1	0	0	0	1	1	0	1	0	0	1	0
442	1	1	1	1	1	1	1	1	0	0	1	1	1	0	1	1
443	1	0	1	0	1	1	0	1	0	0	0	0	0	1	1	0
444	0	1	1	0	1	0	1	0	0	1	1	0	1	1	0	0
445	1	0	1	1	0	0	1	1	1	0	1	1	0	0	1	0
446	0	1	0	0	1	1	1	1	1	0	1	0	0	1	0	1
447	1	1	1	0	1	0	0	1	1	1	1	0	1	0	1	0
448	0	0	1	1	0	1	1	1	1	0	0	0	1	0	0	1
449	1	1	0	1	1	1	0	0	1	1	0	0	0	0	0	1
450	0	0	1	1	1	0	0	0	0	0	0	1	0	0	1	1
451	1	1	0	1	0	0	0	1	0	0	1	0	0	1	0	0
452	1	1	0	1	1	0	0	1	0	0	1	0	1	1	0	1
453	0	0	1	1	0	1	0	0	1	0	1	1	0	0	1	0
454	0	1	1	0	1	0	0	0	1	1	0	1	0	0	1	1
455	1	0	0	1	0	0	1	0	1	1	0	1	1	0	0	0
456	0	0	1	0	1	0	1	1	1	0	0	1	0	0	0	1
457	0	1	1	1	1	0	0	0	1	0	1	0	1	0	1	0
458	1	1	1	1	1	0	0	1	1	0	0	1	0	0	0	1
459	0	0	1	1	1	0	1	1	1	1	0	0	1	0	0	0
460	1	0	0	0	1	0	1	1	1	0	1	1	0	0	0	1
461	1	1	1	1	0	0	1	1	0	1	1	0	0	1	0	1
462	0	0	0	0	1	1	0	1	0	0	1	1	0	1	1	1
463	1	1	1	1	1	0	1	0	1	0	0	1	1	0	0	0
464	0	1	0	1	0	1	1	0	1	1	0	0	1	1	1	1
465	0	1	0	0	0	0	0	1	1	0	0	1	1	0	1	1
466	0	0	1	0	1	0	1	1	0	1	0	1	0	1	0	1
467	1	0	1	1	0	1	1	0	1	0	1	0	0	1	0	1
468	0	0	0	0	1	0	1	0	1	0	0	0	0	0	1	0
469	0	0	0	1	0	0	0	1	0	0	0	0	1	0	0	0
470	0	0	0	0	1	0	1	0	0	0	0	1	0	0	0	0
471	0	1	1	1	1	1	1	0	0	1	1	0	0	0	0	0