

ERTMS/ETCS – Class 1
Euroradio FIS
REF : SUBSET-037 ISSUE : 2.3.0 DATE: 14-Oct-2005

Company	Technical Approval	Management approval
ALCATEL		
ALSTOM		
ANSALDO SIGNAL		
BOMBARDIER		
INVENSYS RAIL		
SIEMENS		

1. MODIFICATION HISTORY

Issue Number Date	Section Number	Modification / Description	Author
2.0.0 30-March- 2000		Final issue to ECSAG	U.D. (ed)
2.1.0 23-November-2001	All	Revision	LK
2.1.7		Version with revision marks	LK
2.2.0		Final issue after revision	LK
2.2.1	3.4, 5.2, 5.3, 7.1.2, 7.2.2, 7.2.4, 7.2.5, 7.3.2, 8.2.3, 8.2.4, 8.3.1, Annex A, B.1, C.1	Review comments of Unisig super group inserted	LK
2.2.1+	7.2.5.3.6, 7.2.5.3.7	State table updated (state DATA, event DT SaPDU -> splitting in to Conditions Pre 5 and Pre 6; state AR SaPDU, event AR SaPDU -> DI SaPDU added)	TS
2.2.1.++	7.3.2.2.1	Table 23 Bit numbering changed	TS
2.2.2r	3.4.1.1, 7.2.5.3.6	Editorial changes	LK
2.2.2	-	Clean version	LK
2.2.3	3., 3.1.1.5, 3.1.16, 3.3, 3.4.1, 7.2.2.2.1.4, 7.2.5.3.7, 8.2.3.1.2, 8.3.1.14	Review comments of GSM- R users group inserted, Clarifications, references updated	LK
2.2.4	-	Clean version	LK
2.2.5	-	Formal release	LK
2.2.5.revA	3.4, 5.2, 5.7, 7.3.3, 8.2.2, 8.2.4, 8.2.5, 8.3.1	Proposed changes according to LOP v 020	LK
2.2.5.revB	3.4, 5.2, 5.7, 7.3.3, 8.2.2, 8.2.3, 8.2.4, 8.2.5, 8.3.1, B.1, B.5	Changes of Neu-Ulm meeting	TS+LK

2.2.5.revC	5.2.1.7, 7.3.3.5.4, 8.2.2.6, 8.2.2.9, 8.2.3.2.3, 8.3.1.1, 8.3.2.2.1, 8.3.3.1.2, B.1.1.1.9	Changes of Berlin meeting	LK
2.2.5.revD	3.4.1, 8.2.5, 8.3.1, 8.3.3, Annex A	Changes of Edinburgh meeting	TS+LK
2.2.5.revE	3.4, 4.1.1.1, 7.2.2.2.2, 7.2.4.2, 7.3.2, 8.2.2, 8.2.4, Annex D, Annex E	Changes of Stockholm meeting and email discussion	LK
2.2.5.revF	3.3, 3.4, 7.2.2, 7.2.4, 7.3.2, 8.2.2, 8.2.5, 8.3.1, AnnexD, AnnexE	Changes of Paris meeting and email discussion	WM+LK
2.2.5.revG	4.1.1.10, 5.71.4, 7.3.3.5.6, 8.2.3.2.5, 8.2.5, 8.2.7, E.2	Changes of Zürich meeting	PL+LK
2.3.0	AnnexE.1, Tables 31, 34, 35	Formal release	JH

2. TABLE OF CONTENTS

1. MODIFICATION HISTORY	2
2. TABLE OF CONTENTS	4
3. GENERAL ASPECTS	6
3.1 Scope.....	6
3.2 Acronyms and abbreviations	6
3.3 Definitions	9
3.4 References	11
3.4.1 Normative References.....	11
3.4.2 Informative References	12
4. REFERENCE ARCHITECTURE	13
5. INTERFACE TO SAFE SERVICES	16
5.1 General.....	16
5.2 Service primitives for safe connection set-up	16
5.3 Service primitives for safe data transfer	18
5.4 Service primitives for connection release	19
5.5 Service primitives for error reporting.....	20
5.6 Service primitives for high priority data.....	21
5.7 Service primitives for network registration	22
6. INTERFACE TO THE MOBILE NETWORK	24
7. SAFE FUNCTIONAL MODULE	25
7.1 Service definition	25
7.1.2 Model of the safe services.....	25
7.1.3 Safe connection set-up.....	26
7.1.4 Safe data transfer	26
7.1.5 Release of safe connection	27
7.1.6 Error reporting	27
7.1.7 Service for high priority data.....	27
7.2 Safety protocol.....	27
7.2.1 Introduction.....	27
7.2.2 Functions of the safety layer.....	28
7.2.3 Time sequences	35
7.2.4 Structure and encoding of safety PDUs	39
7.2.5 State table	43
7.3 Safety Protocol Management	49
7.3.1 Functions of the Safety Protocol Management.....	49

© This document is the property of

ALCATEL * ALSTOM * ANSALDO SIGNAL * BOMBARDIER * INVENSYS RAIL * SIEMENS

7.3.2	Configuration Management	49
7.3.3	Supervision and Diagnostics	50
8.	COMMUNICATION FUNCTIONAL MODULE.....	55
8.1	Service definition	55
8.1.1	Model of communication services	55
8.1.2	Connection establishment	55
8.1.3	Data transfer	56
8.1.4	Connection release.....	57
8.1.5	High priority data	57
8.1.6	Quality of Service	57
8.2	Communication protocols	58
8.2.1	Introduction.....	58
8.2.2	Data Link Layer	58
8.2.3	Network Layer	60
8.2.4	Transport Layer	61
8.2.5	Applicability conditions of X.224	66
8.2.6	Time sequences	71
8.2.7	Relationships of PDUs and SDUs	73
8.3	Management of Communication Functional Module.....	76
8.3.1	Call and ID-Management.....	76
8.3.2	Configuration management	79
8.3.3	Supervision / Diagnostics	81
	ANNEX A (NORMATIVE) ASSUMPTIONS PLACED ON THE ATP APPLICATION	83
	ANNEX B (OPTION) INTERFACE TO COMMUNICATIONS SERVICES.....	84
B.1	Service primitives for connection establishment	84
B.2	Service primitives for data transfer.....	85
B.3	Service primitives for HP data transfer.....	86
B.4	Service primitives for connection release.....	87
B.5	Service primitives for network registration	87
	ANNEX C (OPTION) SAFETY PROTOCOL MANAGEMENT	89
C.1	Management SaPDUs	90
C.2	Error Handling	91
	ANNEX D (INFORMATIVE) APPLICABILITY CONDITIONS OF ISO/IEC 7776 (1995).....	93
	ANNEX E (INFORMATIVE) VERSION INTERWORKING	99
E.1	Subset-037 version 2.0.0 and version 2.2.5.....	99
E.2	Subset-037 version 2.2.5 and version 3.0.0.....	100

3. GENERAL ASPECTS

3.1 Scope

- 3.1.1.1 This FIS is applicable to radio communication systems providing communication services for safety-related application processes using open networks. It specifies for ERTMS/ETCS Class 1 the Radio System Interoperability for message exchange between on-board and trackside equipment in respect to safety-related application processes, like Automatic Train Control of ETCS level 2/3. Additionally, it specifies for ETCS level 1 the optional message exchange between on-board equipment and radio in-fill unit.
- 3.1.1.2 Optionally, this FIS is applicable also to non safety-related application processes using the services of the radio communication subsystem for communication purposes.
- 3.1.1.3 In particular this FIS does not define:
- The application functionality and application information flow.
 - The open networks used.
 - The physical architecture of the radio communication subsystem.
- 3.1.1.4 Within the scope of this document, the terms "Radio Communication System (RCS)" and EURORADIO system are used synonymously.
- 3.1.1.5 Currently, the version handling **fixed for class 1** is as follows:
- There is one version of CFM only.
 - There is one version of SFM only.
- 3.1.1.6 Version upgrade for enhanced Euroradio CFM and SFM, if any, will follow the principle as defined in Unisig class1 SRS:
- The on-board CFM and SFM may operate with several versions.
 - The on-board CFM and SFM will decide whether it can use the protocol data units (PDUs) received from trackside.
 - This version check does not restrict negotiation of connection features by means of QoS class (CFM) or safety feature (SFM).

3.2 Acronyms and abbreviations

- 3.2.1.1 For the purposes of this FIS, the following definitions apply.

AR	Authentication Response
ATC	Automatic Train Control
ATP	Automatic Train Protection

AU1	First Authentication message
AU2	Second Authentication message
AU3	Third Authentication message
BAC	Balanced Asynchronous Class
B _m	Full-rate traffic channel
BS	Bearer Service
CEPID	Connection EndPoint IDentifier
CFM	Communication Functional Module
CSPDN	Circuit Switched Public Data Network
DA	Destination Address
DCE	Data Communication Equipment
DES	Data Encryption Standard
DF	Direction Flag
DI	Disconnect
D _m	Control Channel
DT	Data
DTE	Data Terminal Equipment
eMLPP	Enhanced Multi-Level Precedence and Pre-emption
ERTMS	European Rail Train Management System
ETCS	European Train Control System
ETS	European Telecommunication Standard
ETY	ETCS ID type field in a SaPDU
FEC	Forward Error Correction
FFFIS	Form Fit Functional Interface Specification
FIS	Functional Interface Specification
FRMR	FRaMe Reject
GSM-R	Global System for Mobile Communication - Railway
HDLC	High level Data Link Layer Control
HP	High Priority
ID	Identity
IEC	International Electrotechnical Commission
ISDN	Integrated Services Digital Network
ISO	International Organisation for Standardisation
ITU	International Telecommunication Union
K _{AB}	Authentication Key (same as KMAC)
KM	Key Management
KMAC	Authentication Key

KMC	Key Management Centre
K _s	Session Key (same as KSMAC)
KSMAC	Session Key
KTRANS	Transport Key
LAPB	Link Access Protocol Balanced
m	message
MA	Management
MAC	Message Authentication Code
MS	Mobile Station
MT2	Mobile Termination type 2
MTI	Message Type Identifier
NPDU	Network Protocol Data Unit
NSAP	Network Service Access Point
NSAP	Network layer Service Access Point
NSDU	Network Service Data Unit
NT	Network Termination
O&M	Operation and Maintenance
OSI	Open System Interconnection
PDU	Protocol Data Unit
PLMN	Public Land Mobile Network
PSTN	Public Switched Telephone Network
QoS	Quality of Service
RBC	Radio Block Centre
RCS	Radio Communication System also used as synonym for EURORADIO system
RP	Response
RQ	Request
SA	Source Address
SABME	Set Asynchronous Balanced Mode Extended
SaCEPID	Safe Connection EndPoint Identifier
SaF	Safety Features
SAP	Service Access Point
SaPDU	Safety Protocol Data Unit
SaS	Safety Service
SaSAP	Safety Service Access Point
SaSDU	Safety Service Data Unit
SaUD	Safety User Data
SFM	Safe Functional Module

© This document is the property of

ALCATEL * ALSTOM * ANSALDO SIGNAL * BOMBARDIER * INVENSYS RAIL * SIEMENS

SREJ	Selective REJect
TC	Transport Connection
TCEPID	Transport Connection EndPoint Identifier
TCH	Traffic Channel
TP	Transport Protocol
TP2	Transport Protocol Class 2
TPDU	Transport Protocol Data Unit
TS	Transport Service
TSAP	Transport Service Access Point
TSDU	Transport Service Data Unit
UA	Unnumbered Acknowledge
UI	Unnumbered Information (HDLC frame)
X	Mandatory parameter
X(U)	Use of this parameter is an user option

3.3 Definitions

Mandatory feature:

The feature has to be provided by on-board and/or trackside equipment where interoperability is required.

Optional feature/Option:

The feature might be provided or not. If provided, it has to be provided as specified. Optional features are not required for Class 1. Interoperability between EURORADIO systems providing and not providing the optional feature has to be guaranteed. Otherwise, the option has to be deactivated.

National Add-on:

The feature is a matter of national railway specification. Interoperability must not be influenced.

AUTHENTICATION

(Message origin authentication): The corroboration that the source of the message is as claimed.

AUTHENTICATION

(Peer-entity authentication): The corroboration that a peer entity in an association is the one claimed.

AUTOMATIC TRAIN CONTROL (ATC)

A system for the control of trains, designed to operate without human intervention.

AUTOMATIC TRAIN PROTECTION (ATP)

A means of enforcing the safe running of trains by intervening if a pre-determined safe speed/distance envelope is exceeded.

DATA ENCRYPTION STANDARD (DES)

A *block cipher* published in 1977 by the NBS as a US government norm. DES has been renamed Data Encryption Algorithm (DEA) during its adoption as an *ANSI* standard (X3.92, 1981).

DES KEY

A cryptographic key of length 64 bits, where each eighth bit is an odd parity bit, as defined in ANSI X3.92, 1981. Because of this structure, the effective key length is 56 bits.

DELETION (of a message)

An attack in which a message is erased from the stream of messages.

DATA INTEGRITY

The property that the message has not been modified or destroyed in an unauthorised manner.

FORM FIT FUNCTIONAL INTERFACE SPECIFICATION (FFFIS)

A FFFIS is the complete definition of an interface between functional or physical entities.

The FFFIS includes:

- FIS,
- Electrical characteristics related to data,
- communication protocol¹,
- plug.

The FFFIS guarantees the interoperability but not the exchangeability of physical entities.

FUNCTIONAL INTERFACES SPECIFICATION (FIS)

A FIS specifies the link between functional modules or between physical entities by:

- The required external data flow,
- The required data characteristics,
- The data range and resolution requirements.

FUNCTIONAL MODULE

Set of functions contributing to realize the same global task.

INSERTION (of a new message)

An attack in which a new message is being implanted into the stream of messages.

KEY

A generic term for a cryptographic key. In this specification, it usually refers to a concatenation of three DES keys to give a total length of $3 \times 64 = 192$ bits.

KEY MANAGEMENT

The generation, storage, distribution, deletion, archiving and application of keys in accordance with a security policy.

MESSAGE AUTHENTICATION CODE (MAC)

An authenticator which is sent with a message to enable the receiver to detect alterations made to

¹Note that 'Communication protocol' is used with different meanings in the EuroRadio FIS and FFFIS:

In the FIS a communication protocol is a protocol between peer entities within different End Systems connected by a network.

In the FFFIS a communication protocol is a protocol between functional modules or physical entities located in the same End System.

the message since it left the sender and to verify that the source of the message is as claimed. The MAC is a function of the whole message and a secret key.

MODIFICATION (of a message)

Any unauthorised change of any part of a message.

PADDING

The information used to fill the unused part of a message to fill the block size.

RADIO COMMUNICATION SYSTEM

A radio transmission system providing data communication services via open networks. It can be completed by an safety related transmission system to ensure safe data transmission. .

REPETITION/REPLAY

An attack in which a message is stored and re-transmitted later.

3.4 References

3.4.1 Normative References

3.4.1.1 This FIS incorporates by dated or undated references, provisions from other publications. The relevant parts of these normative references are cited at the appropriate place in the text and the publications are listed hereafter. For dated references, subsequent amendments to or revisions of any of these publications apply to this FIS only when incorporated in it by amendment or revision. For undated references the latest edition of the publication referred to applies.

Subset-026	02.02	ERTMS/ETCS Class 1; Subset-026; Unisig SRS, version 2.2.2
Subset-093	07.03	ERTMS/ETCS Class 1; Subset 093; GSM-R interfaces; Class1 requirements, version 2.2.6
Subset-038	06.03	ERTMS/ETCS Class 1; Subset 038; Off-line Key management FIS, version 2.0.0
Subset-040	10.99	ERTMS/ETCS Class 1; Subset 040; Dimensioning and Engineering Rules, version 2.0.0
EIRENE FRS	10.03	EIRENE Project Team. Functional Requirement Specification. Version 6.0, MDA029D009
EIRENE SRS	10.03	EIRENE Project Team. System Requirement Specification. Version 14.0, MDA029D010
Euroradio FFFIS	09.03	UIC ERTMS/GSM-R Unisig; Euroradio Interface Group; Radio Transmission FFFIS for Euroradio; A11T6001; version 12
EN 50159-2	03.01	Safety-Related Communication in Open Transmission Systems
ITU-T E.212	11.98	The international identification plan for mobile terminals and mobile users
ITU-T X. 214	11.93	Information Technology - Open System Interconnection - Transport service definition
ITU-T X. 224	11.93	Protocol for providing the OSI connection-mode transport service
ITU-T T.70	03.93	Network-independent basic transport service for telematic

© This document is the property of

ALCATEL * ALSTOM * ANSALDO SIGNAL * BOMBARDIER * INVENSYS RAIL * SIEMENS

		services
ITU-T T.90	01.92	Characteristics and protocols for terminals for telematic services in ISDN
ISO/IEC 3309	12.93	HDLC procedures; Frame structure
ISO/IEC 4335	12.93	HDLC procedures; Elements of Procedures
ISO/IEC 7776	07.95	Description of the X.25 LAPB-compatible DTE data link procedure
ISO/IEC 7809	12.93	HDLC procedures; Classes of Procedures
ISO/IEC 9797-1	12.99	Information technology - Security techniques - Messages Authentication Codes (MACs) - Part 1: Mechanisms using a block cipher
ANSI X3.92	12.80	American National Standard Data Encryption Algorithm

3.4.2 Informative References

FIS LDA	09.96	Morane FIS for Location-Dependent Addressing F12T6001
ETS 300011	1992	ISDN; Primary rate user-network interface; Layer 1 specification and test principles
ETS 300102-1	1990	ISDN; User-network interface layer 3; Specification for basic call control
ETS 300125	1991	ISDN; User-network interface data link layer specifications
EN 300924	04.99	Enhanced Multi-Level Precedence and Pre-emption Service (eMLPP) Stage 1 (GSM 02.67)
TS 100936	02.97	Layer 1; General Requirements (GSM 04.04)
EN 300938	07.99	MS - BSS interface; Data link layer specification (GSM 04.06)
EN 300940	04.99	Mobile radio interface; Layer 3 specification (GSM 04.08)
TS 100916	03.96	AT command set for GSM Mobile Equipment (GSM 07.07)

4. REFERENCE ARCHITECTURE

- 4.1.1.1 EN 50159-2 defines the reference architecture for safety-related systems using open transmission systems. The general structure of a safety-related system such as the European Train Control System (Figure 1) is derived from EN 50159-2.
- 4.1.1.2 In addition to safety-related information, application processes in the safety-related equipment can exchange non-safety related information with remote application processes using the services of the radio communication system.

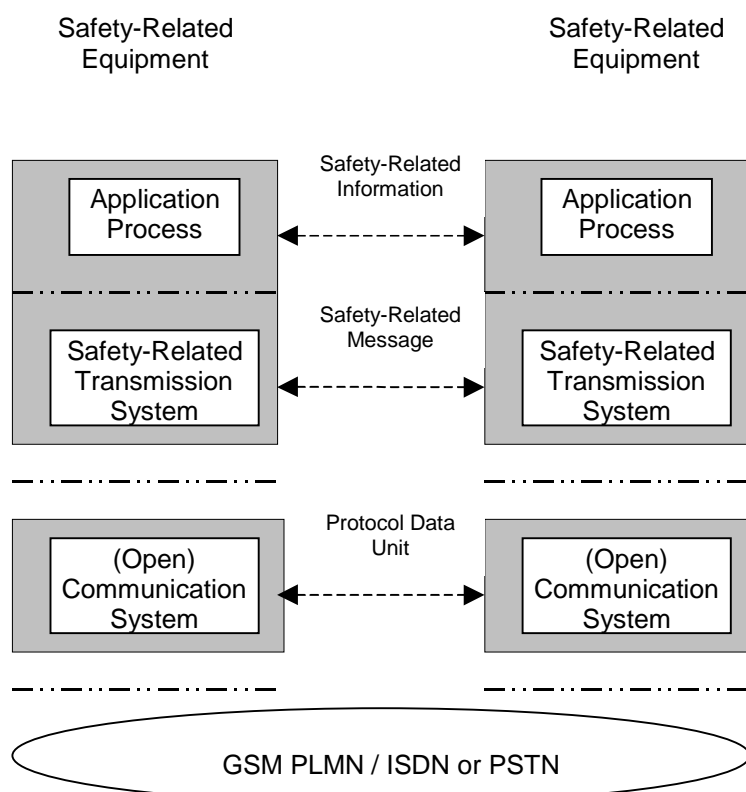

Figure 1 Structure of the radio communication system

- 4.1.1.3 For the purposes of this FIS the "Open Transmission System" of EN 50159-2 is divided into components: the Communication System and the Open Network. The open (public or railway owned) network is out of scope for this part of the FIS. Only the service features requested at the interface to the network are covered.
- 4.1.1.4 The Safety Functional Module (SFM) of the RCS provides the functions of the safety-related transmission system. The Communication Functional Module (CFM) of the RCS provides the functions of the communication system based on circuit switched bearer services of the GSM-R PLMN. **Figure 2** contains a detailed reference architecture of the radio communication subsystem based on a circuit switched bearer service. The service interfaces and the protocol interfaces are defined.

4.1.1.5 Interface 1 is an interface between the RCS and the chosen transmission medium. It consists of a user plane for transfer of user data and a control plane for connection management. Interface 1a is the GSM PLMN-Interface (on board). Interface 1c is the recommended on-board interface between the RCS and the mobile termination MT2 (refer to EURORADIO FFFIS). Interface 1b is the Interface to fixed networks (trackside). In **Figure 2** a primary rate interface to ISDN-like networks is shown. ISDN basic rate interface and PSTN are not excluded.

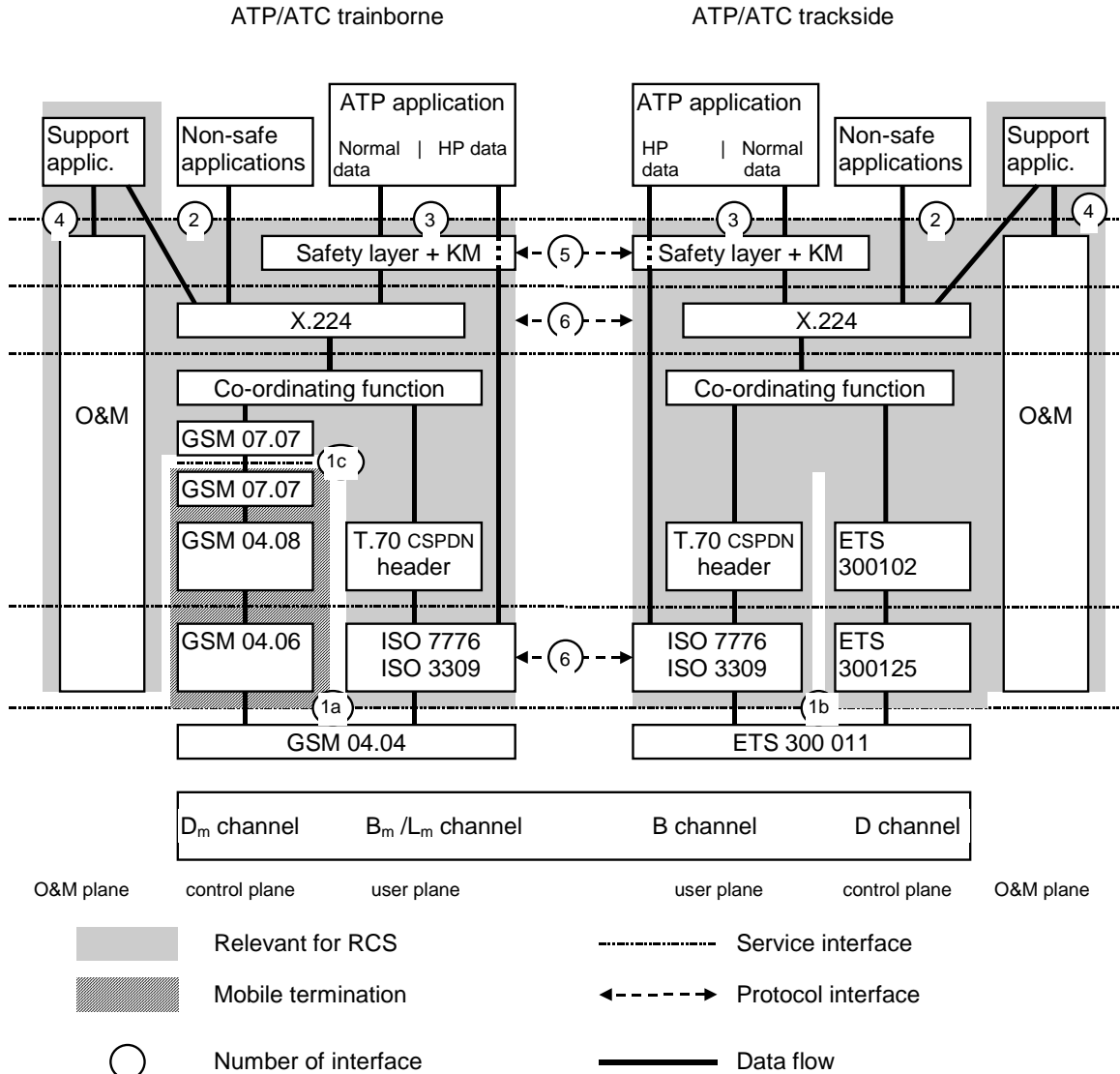

Figure 2 Reference architecture of EURORADIO system

4.1.1.6 Interface 3 is a service interface between safe applications (e.g. ATP/ATC) and the Safe Functional Module (safety layer).

4.1.1.7 Interface 2 is an optional service interface between non-safe applications or support applications and the Communication Functional Module. This option is not required for ETCS level 1 radio in-fill unit.

4.1.1.8 The service interfaces 2 and 3 are not mandatory for interoperability. Only a functional definition is provided.

- 4.1.1.9 Logical peer entity interfaces 5 and 6 are mandatory for interoperability. The interface is specified in terms of protocol data units and communication relevant aspects of module functionality.
- 4.1.1.10 The O&M plane covers all operations and management aspects. Key management (KM) for the safe layer is not specified here. Interface 4 is a local service interface to the O&M stack, which is not specified.

5. INTERFACE TO SAFE SERVICES

5.1 General

5.1.1.1 The safe services provided by the SFM are accessed by means of safe service primitives with their corresponding parameters at the SaSAP. The safe service primitives are similar to the service primitives defined in X.214 for connection mode service.

5.1.1.2 **Class 1 requirement:** The interface is mandatory at functional level only.

5.1.1.3 NOTE: It is a matter of implementation to adapt this interface to implementation needs and constraints, which do not require any exchange on the air gap and that have no impact on the behaviour of the system.

5.2 Service primitives for safe connection set-up

5.2.1.1 The safe connection set-up service is based on the use of the following primitives:

Table 1 Service primitives of the safety layer for connection set-up

Parameter	SaS-Primitive	Sa-CONNECT. request	Sa-CONNECT. indication	Sa-CONNECT. response	Sa-CONNECT. confirm
SaCEPID			X	X(=)	X
Called address					
<ul style="list-style-type: none"> • Address type • Network address • Mobile network ID • Called ETCSID type • Called ETCS ID 		X X(D) X(U) X X	X X		
Calling address					
<ul style="list-style-type: none"> • Calling ETCS ID type • Calling ETCS ID 		X(D) X(D)	X(=) X(=)		
Responding address					
<ul style="list-style-type: none"> • Responding ETCS ID type • Responding ETCS ID 				X(D) X(D)	X(=) X(=)
Application type		X	X(=)		
Quality of service class		X(D)			
<p>X: mandatory parameter.</p> <p>(=): the value of that parameter is identical to the value of the corresponding parameter of the preceding SaS primitive, if any.</p> <p>X(U) Use of this parameter is an user option</p> <p>X(D) Use of this parameter is an user option. If not provided, a default value will be used.</p>					

- 5.2.1.2 **SaCEPID:** The local parameter "Safe connection endpoint identifier (SaCEPID)" is provided locally to identify each safe connection at a SaSAP.
- 5.2.1.3 The **Called address** identifies the called SFM user.
- 5.2.1.4 The **Address type** qualifies the usage of sub-parameters of called address (refer to section 8.3.1 for details).
- 5.2.1.5 The **Network address** contains the network address of the called SaS user. This parameter is composed of sub-fields, e.g. the length of the called number, the type of number, the numbering plan, and the number itself.
- 5.2.1.6 The **Mobile network ID** identifies the mobile network.. The mobile network ID shall consist of the Mobile Country Code and the Mobile Network Code according to [ITU-T E.212].
- 5.2.1.7 In the case of mobile originated calls, the connection request should contain the sub-parameter Mobile network ID, to request the appropriate network associated with the called SaS-user.
- 5.2.1.8 The parameter **ETCS ID type** together with **ETCS ID** is unique within the scope of ETCS and refers to ETCS equipment. The ETCS IDs are used by the safety layer during peer entity authentication. The ETCS-Id type and ETCS ID together with the application type identifies the safety service user.
- 5.2.1.9 **Called ETCS ID:** The Called ETCS ID parameter conveys the ETCS ID associated with the SaS-user to which the safe connection is to be established.
- 5.2.1.10 **Calling ETCS ID:** The Calling ETCS ID parameter conveys the ETCS ID of the requesting SaS-user from which the safe connection has been requested.
- 5.2.1.11 **Responding ETCS ID:** The Responding ETCS ID parameter conveys the ETCS ID of the SaS-user to which the safe connection has been established.
- 5.2.1.12 **Application type:** The application type is identical at the calling and called side (see section 8.2.4.6).
- 5.2.1.13 **Quality of Service class:** The QoS parameters give SFM users a method of specifying their needs, and give the CFM a basis for selection of the protocol or for requesting services of lower layers. The **QoS class** is associated with a set of quality of service parameter values (see section 8.3.2.2). The QoS parameters will not be negotiated. The requested QoS parameter values have to be accepted by the service provider and the peer application, otherwise the connection establishment has to be rejected.

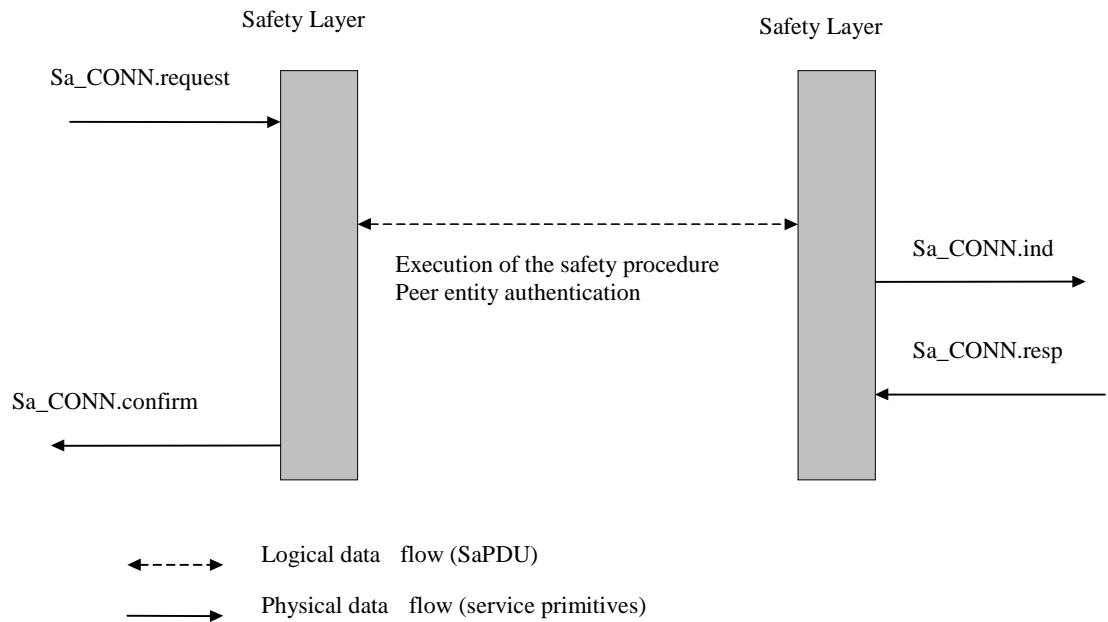

Figure 3 Sequence of primitives for safe connection set-up

- 5.2.1.14 **Sa-CONNECT.request** initiates the establishment of a safe connection. The safety protocol enforces a connection set-up of the underlying transmission system by using T-CONNECT.request.
- 5.2.1.15 **Sa-CONNECT.indication** is used by the called safety layer entity to inform the called SaS user about the safe connection establishment request.
- 5.2.1.16 **Sa-CONNECT.response** is used by the responding SaS user to accept the connection to the safety layer entity.
- 5.2.1.17 **Sa-CONNECT.confirm** is used by the initiating safety layer entity to inform the calling SaS user about the successful establishment of the safe connection after a response of the called SaS user was obtained.
- 5.2.1.18 Simultaneous requests for safe connection set-up at two SaSAP's are handled independently by the safety layer. These simultaneous requests result in a corresponding number of safe connections. It is the matter of the requesting SaS user to distinguish between confirmations of pending Sa-CONNECT.requests.

5.3 Service primitives for safe data transfer

- 5.3.1.1 For the data transmission two service primitives for the transmission and reception of messages are defined.

Table 2 Service primitives of the safety layer for data transfer

Parameter	Primitive	Sa-DATA.request	Sa-DATA.indication
SaCEPID		X	X
Sa user data		X ¹	X(=)
Note1: The length has to be at least 1 octet.			

- 5.3.1.2 Sa-DATA.request on transmission and Sa-DATA.indication on reception perform the safe transfer and the safety procedure ‘message origin authentication’. After the execution of the safety procedure ‘message origin authentication’ the transmitting safety entity forwards the data (user data expanded with a Message Authentication Code) to the transport layer.
- 5.3.1.3 The user data are transported transparently by the SFM. The recommended size of Sa user data is ≤ 114 octets. The maximum length of SaS user data to be transferred is restricted to 1023 octets.
- 5.3.1.4 On reception, after successful execution of the procedure ‘message origin authentication’, the user data are delivered to the SaS user using the service primitive Sa-DATA.indication. In the error case, a Sa-REPORT.indication or a Sa-DISCONNECT.indication is delivered.

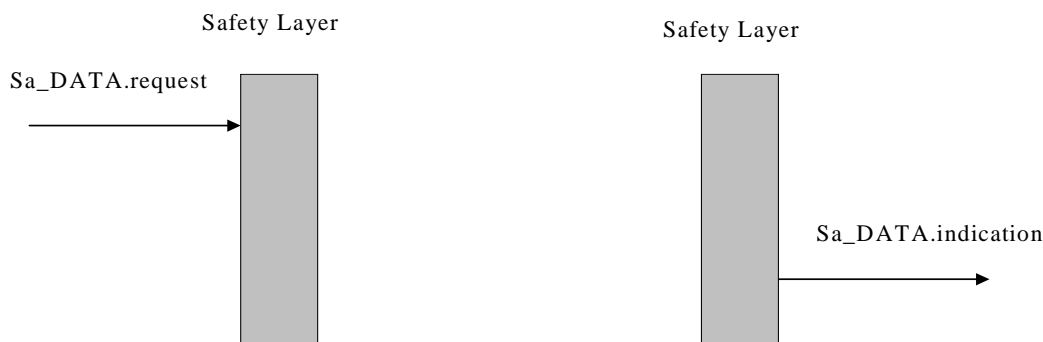

Figure 4 Sequence of primitives for safe data transfer

- 5.3.1.5 The operation of the safety layer in transferring SaS user data can be modelled as a queue. The ability of a SaS user to issue a Sa-DATA.request depends on the state of the queue. The ability of the safety layer to issue a Sa-DATA.indication depends on the receiving SaS user.

5.4 Service primitives for connection release

- 5.4.1.1 Connection release, i.e. disconnect, is supported by the following two service primitives.

Table 3 Service primitives of the safety layer for connection release

Parameter	Primitive	Sa-DISCONNECT.request	Sa-DISCONNECT.indication
SaCEPID		X	X
Disconnect reason		X	X
Disconnect sub-reason		X(U)	X

- 5.4.1.2 Sa-DISCONNECT.request is used by the SaS user to enforce a release of the safe connection.
- 5.4.1.3 Sa-DISCONNECT.indication is used to inform the SaS user about a connection release of the safe connection.
- 5.4.1.4 The reason and sub-reason codes are defined in section 7.3.3.3 "Error handling".
- 5.4.1.5 Normal release requested by a SaS user shall contain the reason code 0; the sub-reason code can be set by the SaS user according to its needs in the range 0...255.

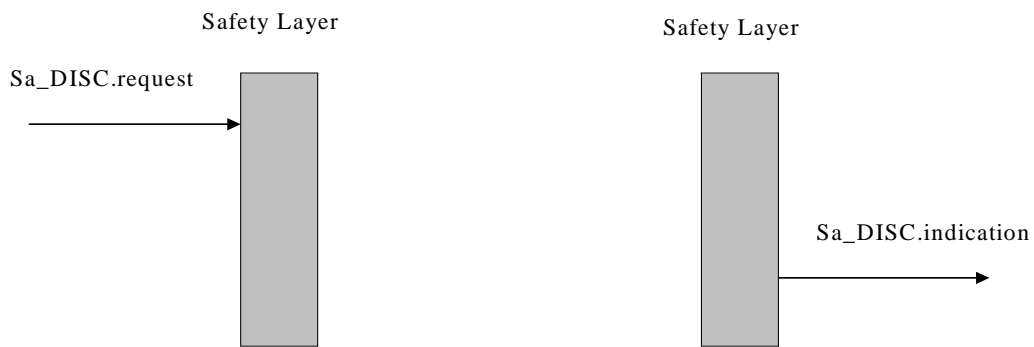

Figure 5 Sequence of primitives for connection release initiated by a SaS user

- 5.4.1.6 The safety layer can issue an unsolicited Sa-DISCONNECT.indication at any time during the connection set-up phase or during the data transfer phase. The release of the connection can be caused by inability of the safety layer to provide a given service.
- 5.4.1.7 Other sequences of primitives for connection release are possible.

5.5 Service primitives for error reporting

- 5.5.1.1 Optionally, error reporting is supported by the service primitive Sa-REPORT.indication

Table 4 Service primitives for error reporting

Parameter	Primitive	Sa-REPORT.indication
SaCEPID		X
Report type		X

Number of tuples	X
List of tuples	X

5.5.1.2 The safety layer uses the service primitive Sa-REPORT.indication to inform the SaS user about errors that occur in the safety layer or in the lower layers. The Sa-REPORT.indication is triggered automatically (if the Sa-REPORT.indication is the specified error reaction). The service primitive can be used also for reporting information other than errors (e.g. diagnostics).

5.5.1.3 The parameter **report type** is used to distinguish between the different kinds of information reports. Currently, report type =1 is defined only for error reports.

5.5.1.4 A **tuple** contains 2 parameters (reason, sub-reason).

5.6 Service primitives for high priority data

5.6.1.1 The service for high priority data is accessed through the following two service primitives:

Table 5 Service primitives for high priority data

Parameter	Primitive	Sa-HP-DATA.request	Sa-HP-DATA.indication
SaCEPID		X	X
Sa user data		X	X(=)

5.6.1.2 The length of **user data** is restricted to maximum 25 octets.

5.6.1.3 High priority data are transmitted unreliably and non-safely. It is not guaranteed that the receiver receives the HP data. The SaS user has to provide the proper acknowledgement and repetition, if required.

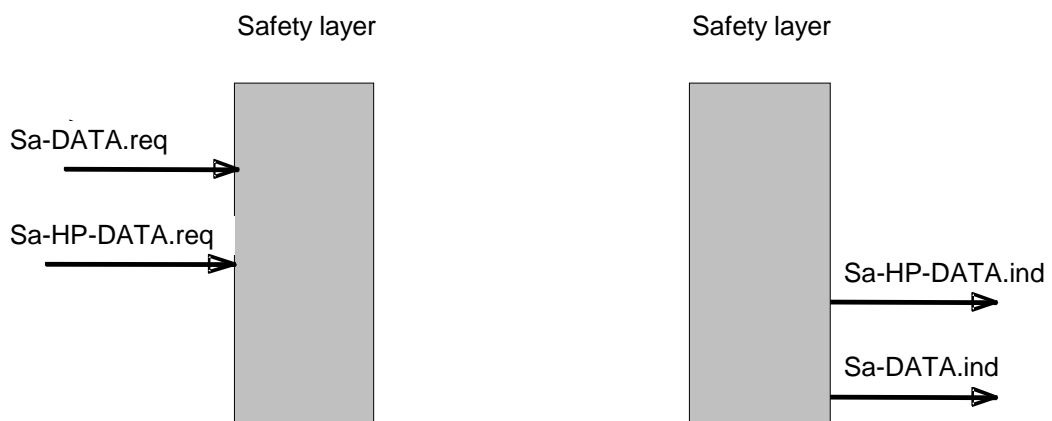

Figure 6 Relationship between data transfer service primitives (example)

5.6.1.4 The sequence of primitives for high priority data is similar to that of safe data transfer. Figure 6 shows as an example the changed sequence of service primitives at the service interface.

5.7 Service primitives for network registration

5.7.1.1 Two service primitives are provided for network registration of Mobile stations (MS) (see Table 6):

- to request mobile network registration and
- to indicate mobile network registration status

5.7.1.2 These service primitives do not provide safe services (i.e. they are not safety relevant and have no impact on the safety protocol).

5.7.1.3 The service primitives are forwarded to/from the Communication Functional Module (CFM) and interpreted as command/response at the interface to mobile network. As a matter of implementation the service primitives of section B.5 may be used instead.

5.7.1.4 These service primitives apply to On Board Units only.

Table 6 Service primitives for network registration

Parameter	Primitive	Sa-REGISTRATION.request	Sa-REGISTRATION.indication
MNID list		X (≥ 0 MNIDs)	X (≥ 0 MNIDs)

5.7.1.5 By means of the service primitive “Sa-REGISTRATION.request” the service user is able to request the registration of one or more mobile stations with one or more mobile networks.

5.7.1.6 **MNID list** is a list of mobile network IDs.

5.7.1.7 A **Mobile network ID** identifies the mobile network a local mobile station is requested to register with. The mobile network ID shall consist of the Mobile Country Code and the Mobile Network Code according to [ITU-T E.212].

5.7.1.8 The interpretation of the MNID list is matter of implementation. An example can be:

Empty :

All available mobile stations are requested to be registered using automatic network registration from GSM-R on-board radio equipment (see GSM 02.11).

One entry:

All available mobile stations are requested to be registered on network defined by the entry using manual network registration from GSM-R on-board radio equipment.

Two different entries (MNID#1, MNID#2):

The available mobile stations have to be split in two parts and to register first part on network defined by MNID #1 and second part on network defined by MNID #2.

In case not enough mobile stations are available to perform registration on both networks, registration shall be provided according to priority in the list : MNID # 1 shall be delivered first.

- 5.7.1.9 The status of registration with mobile networks is indicated by the service primitive “Sa-REGISTRATION.indication” to the service user. The service primitive contains a list of mobile network IDs, which are usable because mobile station(s) are registered with them.
- 5.7.1.10 NOTE: the association between MS and MNID in these service primitives is a local implementation matter.
- 5.7.1.11 The service user is not informed on how many mobile stations are available but receives only status of registered network which means implicitly that connection request on these networks can be issued or not.
- 5.7.1.12 If the indicated list of mobile network IDs is empty, the registration of mobile stations was not possible or the coverage has been lost.
- 5.7.1.13 The network registration indication can be given independently of a request. This feature allows indications after power-up or after loss of coverage. Any change on network registration can be indicated.

6. INTERFACE TO THE MOBILE NETWORK

6.1.1.1 The requirements to the mobile network are specified by [Subset-093].

7. SAFE FUNCTIONAL MODULE

7.1 Service definition

- 7.1.1.1 The service interface between safety layer user and safety layer is not mandatory for interoperability.
- 7.1.1.2 This section specifies an interface between the Safe Functional Module (SFM) and the users of the SFM. It gives the data flows to/from the Safe Functional Module, which provides safe services. In the following, the safe service users will be designated by SaS user. The SaS user exchanges data with the SaS provider.
- 7.1.1.3 The safety services provide safe connection set-up, and safe data transfer during the connection lifetime. The safe data transfer provides data integrity and data authenticity. The SFM reports the errors that occur in the safety layer and transfers error indications from the lower layers.

7.1.2 Model of the safe services

- 7.1.2.1 A safety entity communicates with its users through one or more safe service access points (SaSAP) by means of the safe service primitives. The peer safety entities support safe connection exchanges by means of safety protocol data units (SaPDU). These protocol exchanges use the services of the transport layer via one Transport Connection (TC) through one transport service access point (TSAP), i.e. the safety entity plays the role of an TS user. The exchange of SaPDUs is a logical view only. Normal service primitives transmit normal data and HP- primitives transmit HP-data.

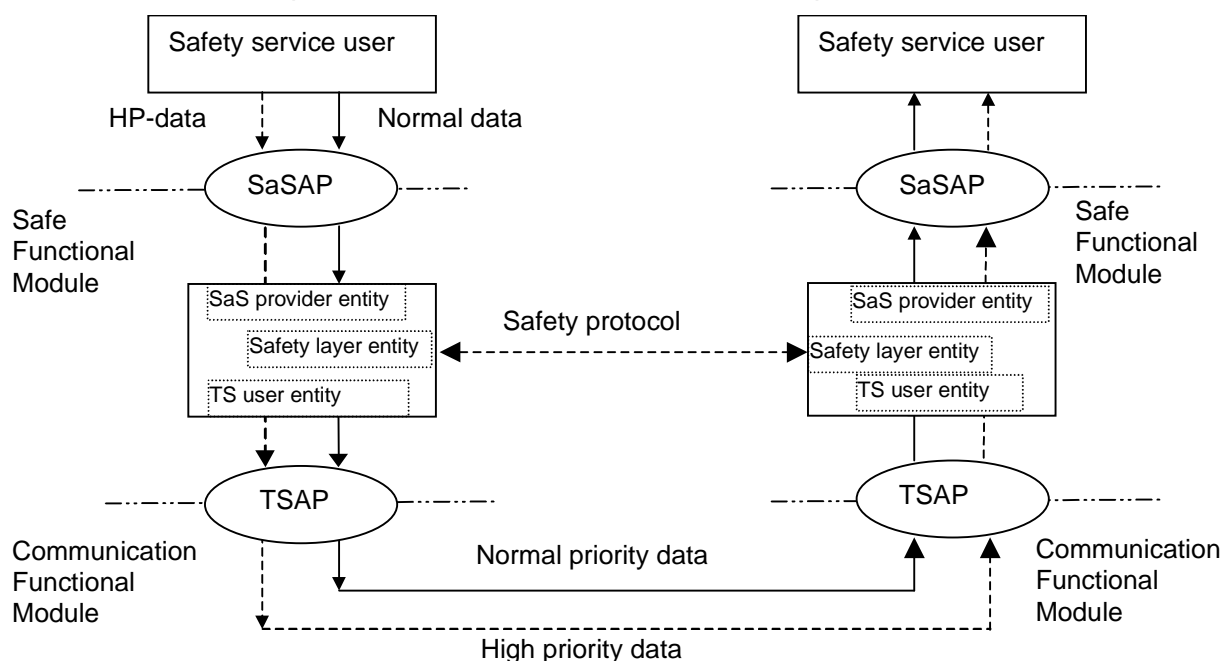

Figure 7 Model of the safe services

© This document is the property of

ALCATEL * ALSTOM * ANSALDO SIGNAL * BOMBARDIER * INVENSYS RAIL * SIEMENS

7.1.2.2 This figure contains a model only. It does not restrict any implementations.

7.1.3 Safe connection set-up

7.1.3.1 Peer entity authentication is provided by the safety protocol between safety layer entities. At connection set-up request, the safety layer will activate the corresponding safety mechanisms to provide entity authentication.

7.1.3.2 The process of establishing a safe connection is initiated at the time when the SaS user requests a connection to the safety layer. The SaS user will send address information and QoS requirements to the safety layer qualifying the request for connection establishment. This QoS value is forwarded to the Communication Functional Module (CFM) and interpreted as a request for a predefined set of quality of service values.

7.1.3.3 The service of providing a safe connection is realised by the execution of the safety procedure 'peer entity authentication'. The establishment of a transport connection between trackside and trainborne is a precondition for the establishment of the safety connection.

7.1.3.4 Any error in the execution of the safety procedure 'peer entity authentication' will result in the rejection of the connection establishment and in the release of the transport connection.

7.1.4 Safe data transfer

7.1.4.1 The safety layer provides for an exchange of user data in both directions simultaneously, and preserves the integrity and boundaries of user data.

7.1.4.2 The Safe Functional Module entity guarantees safe data transfer for safety related messages. The safe data transfer service makes use of the safety procedure 'message origin authentication'.

7.1.4.3 The 'message origin authentication' procedure provides a protection against message integrity violation and against insertion of new messages by unauthorised users of the transmission channel. Message integrity violation means any modification of a message from an active attack or due to random transmission channel errors.

7.1.4.4 Each time a SFM entity receives a data message, delivered by the transmission system (the messages coming from SaS users are considered safe), it shall verify that the message was sent by its peer entity, and that the message has not been altered during its transmission. Both operations, i.e. authentication of the sender, and confirmation of message integrity are realized by the execution of the procedure 'message origin authentication'.

7.1.5 Release of safe connection

7.1.5.1 The release of a safe connection is performed by:

- a) either or both of the SaS users by releasing an established safe connection
- b) the safety layer by releasing an established safe connection
- c) either or both SaS users by abandoning the safe connection establishment
- d) the safety layer by indicating its inability to establish a requested safe connection

7.1.5.2 The release of a safe connection is permitted at any time regardless of the current safe connection phase. A request for a release cannot be rejected. The safe service does not guarantee delivery of any Sa user data once the release phase is entered.

7.1.5.3 The request by the SaS user for the release of a safe connection does not need specific safety protection unlike safe connection set-up, because the release of the connection impacts only on availability. In addition, a safe connection is meaningful only if the underlying connections of the lower layers are not released, and a transport or network connection can be released independently from the safety layer.

7.1.6 Error reporting

7.1.6.1 The safety layer provides an error reporting function to the SaS user for the established safe connection. Errors occurring are either indicated by the release of the safe connection or optionally by an error report. The inability of the safety layer to provide a service will be reported to the SaS user.

7.1.7 Service for high priority data

7.1.7.1 The safety layer does not provide protection for high priority data. The service cannot be used before successful establishment of the safe connection, i.e. it can only be used after successful execution of the safety procedure 'peer entity authentication'.

7.1.7.2 The length of high priority data is restricted.

7.1.7.3 **Class 1 requirement:** It is **mandatory** to be able to transfer HP data from RBC to the train.

7.2 Safety protocol

7.2.1 Introduction

7.2.1.1 This section provides a precise specification of the safety protocol taking into account the CENELEC standard EN 50159-2. The method used in the SFM corresponds to the A1 type in EN 50159-2: cryptographic safety code using secret key.

7.2.2 Functions of the safety layer

7.2.2.1 The safety layer provides the safe transfer of user data. This includes the establishment and release of the safety connection.

7.2.2.2 Safety procedures

7.2.2.2.1 Message origin authentication / Message integrity

7.2.2.2.1.1 Message origin authentication/message integrity is a safety procedure ensuring the integrity and authenticity of messages during transmission. It is used to protect the messages against modification and to ensure that no one can masquerade as the originator of the message. In the following, the procedure is simply called *message origin authentication* because message origin authentication automatically provides message integrity.

Procedure 1: Message Origin Authentication (MAC) on Transmission (m, K_S)

Input: Message m and cryptographic key K_S, which is shared between the sender (with the source address SA) and the receiver (with the destination address DA); SA and DA are ETCS Identities.

Procedure:

- 1.) Set direction flag of message m (value '0' for initiator, value '1' for responder).
- 2.) Append the destination address (DA) in front of the message m: "DA | m".
- 3.) Compute length l of string "DA | m" in octets and append length (2 octets ²) in front of the string for MAC computation, i.e. $l | DA | m$
- 4.) If the length of the message ($l | DA | m$) in bits is not a multiple of 64 then perform padding as defined below for $l | DA | m$ and append padding data p : ($l | DA | m | p$)
- 5.) Compute MAC for the string " $l | DA | m | p$ " using the CBC-MAC function and the cryptographic key K_S :

MAC(m)=CBC-MAC(K_S, $l | DA | m | p$), where | denotes concatenation

Output: If no error occurs MAC(m), which is appended to m. Otherwise, inform the error management.

7.2.2.2.1.2 Message origin authentication is performed as follows:

7.2.2.2.1.3 On transmission of a Data (DT) SaPDU, a Management (MA) SaPDU, the second authentication message (AU2) SaPDU, the third authentication message (AU3) SaPDU, or the Authentication Response (AR) SaPDU, a MAC of length 64 bit is computed using the message m and the cryptographic key K_S as input.

7.2.2.2.1.4 The computation of the MAC in all cases is according to ISO 9797-1. The block cipher used is the single DES with modified MAC algorithm 3 ; where the last data block in the

² The bits in the two octets are numbered from 16 to 1, where bit 1 is the lowest order bit.

MAC computation will be computed as encipher with K1, decipher with K2, then encipher with K3 (this is a modification of IEC9797-1 which uses only two keys, K and K"). IEC9797-1 Padding Method 1 is used (see section 7.2.2.2.1.9).

- 7.2.2.2.1.5 For these SaPDUs, the cryptographic key K_s used for the computation of the MAC is a session key derived during connection set-up. In addition, in the case of a management SaPDU the key K_s is the session key derived during connection set-up. The length of the key $K_s = (K_1, K_2, K_3)$ has to be 192 bits including parity bits. In order to get three 64-bit DES-keys for the single DES with modified MAC algorithm 3 from the three 64-bit session key generation outputs, each eighth bit of the 192-bits should be set to an odd-parity value as defined in the standard ANSI X3.92. However, setting the parity bits is an implementation matter where the key is internal to an equipment
- 7.2.2.2.1.6 High priority data are sent without MAC protection.
- 7.2.2.2.1.7 The ETCS Identity of the receiver (DA) is appended before the message "m" for the MAC computation. The Identity is binary coded by 24 bits. If the address is shorter, bits set to zero are added before the address to obtain a receiver identity (DA) of 24 bits.
- 7.2.2.2.1.8 The length ℓ of the string "DA | m" is computed and appended before the string "DA | m" for the MAC computation. The length ℓ is binary coded by 16 bits (without sign) and is not transmitted because the receiver can compute it.
- 7.2.2.2.1.9 If necessary, i.e. if the length of this string " ℓ | DA | m" in bits is not a multiple of 64, padding is performed prior to the computation of the MAC. As few zero bits as needed (possibly none) are added to the message (ℓ | DA | m) to obtain a multiple of 64 bits. The padding data p is not transmitted because the receiver can compute them, knowing the padding algorithm used.
- 7.2.2.2.1.10 The CBC-MAC(K,X) function using a secret key K and an arbitrary data string X for which a MAC has to be computed is defined as follows:
- 7.2.2.2.1.11 Let $K = (K_1, K_2, K_3)$, let X be constituted by the 64-bit blocks X_1, X_2, \dots, X_q . Let $E(K_n, Y)$ be the block cipher, single DES, enciphering the data string Y using the key K_n ($n \in \{1, 2, 3\}$), $E^{-1}(K_n, Y)$ is the block cipher in the decryption mode, and let \oplus be the XOR-operation. Then, H_q is derived by the following iteration:
- $$H_0 = 0,$$
- $$H_i = E(K_1, H_{i-1} \oplus X_i), \quad i = 1, 2, \dots, q-1$$
- $$H_q = E(K_3, E^{-1}(K_2, E(K_1, H_{q-1} \oplus X_q)))$$
- 7.2.2.2.1.12 The MAC of the data string X is then equal to H_q .
- 7.2.2.2.1.13 In the case of a DT SaPDU the message $m = '000' | MTI | DF | SaUD$ consists of the message type identifier (MTI) indicating a DT SaPDU, the direction flag (DF), and the Safety-User Data SaUD.

- 7.2.2.2.1.14 Concerning the AU2 SaPDU, the message $m = \text{ETY} \mid \text{MTI} \mid \text{DF} \mid \text{SA} \mid \text{SaF} \mid \text{auth2}$ consists of the ETCS ID type, the message type identifier (MTI) indicating AU2 SaPDU, the direction flag (DF), the source address (SA), the safety features (SaF) and the corresponding authentication message $\text{auth2} = \text{Ra} \mid \text{Rb} \mid \text{B}$.
- 7.2.2.2.1.15 Concerning the AU3 SaPDU, the message $m = \text{'000'} \mid \text{MTI} \mid \text{DF} \mid \text{auth3}$ consists of the message type identifier (MTI) indicating AU3 SaPDU, the direction flag (DF), and the corresponding authentication message $\text{auth3} = \text{Rb} \mid \text{Ra}$.
- 7.2.2.2.1.16 In the case of the AR SaPDU the message $m = \text{'000'} \mid \text{MTI} \mid \text{DF}$ consists of the message type identifier (MTI) indicating the AR SaPDU and the direction flag (DF).
- 7.2.2.2.1.17 The direction flag is used as a protection against reflection attacks. It is initialised during connection set-up. Its value is zero when the initiator transmits a message and one when the responder of the connection transmits a message.
- 7.2.2.2.1.18 If an error occurs during the MAC computation the error management is informed and takes over further actions. If no error occurs the output of the MAC computation is the MAC of the message m to be transmitted.

Procedure 2: Message Origin Authentication (MAC) on Reception (m , K_S , $\text{MAC}'(m')$)

Input: Message m including a direction flag, cryptographic key K_S which is shared between the sender and receiver (DA is the identity of the receiver), and $\text{MAC}'(m')$, which is the MAC computed for m' by the sender.

- Procedure:**
- 1.) Append the destination address (DA) in front of the message m : " $DA \mid m$ ".
 - 2.) Compute length l of the string ($DA \mid m$) in octets and append length (2 octets³) in front of the string for MAC computation, e.g. " $l \mid DA \mid m$ ".
 - 3.) If the length of the message ($l \mid DA \mid m$) in bits is not a multiple of 64 then perform padding as defined above for $l \mid DA \mid m$ and append padding data p ;" ($l \mid DA \mid m \mid p$)
 - 4.) Compute MAC for the string ($l \mid DA \mid m \mid p$) using the CBC-MAC function and the cryptographic key K_S : $\text{CBC-MAC}(K_S, l \mid DA \mid m \mid p)$
 - 5.) Compare MAC with MAC' .
 - 6.) Verify the value of the direction flag

Output: Message m is forwarded to the SaS-user if $\text{MAC} = \text{MAC}'$ and the value of the direction flag is correct. Otherwise, inform the error management.

³ The bits in the two octets are numbered from 16 to 1, where bit 1 is the lowest order bit.

7.2.2.2.1.19 On reception of a DT SaPDU, an MA SaPDU, an AU2 SaPDU, an AU3 SaPDU, or an AR SaPDU, a MAC is computed in a similar way to the transmission case. The input parameters are the message m , the cryptographic key K_S and the MAC transmitted as part of the received SaPDU. The receiver of the message uses the same parameters, i.e. cryptographic key and algorithms, as the transmitter of the message, derived from the sender and receiver identities and the type of message. The message m consists of the same parts as described above. The receiver adds its ETCS identity (DA) and computes the length l of the string "DA | m " which has to be added before the message m for the MAC computation and the padding data p , if necessary.

7.2.2.2.1.20 If this MAC for " l | DA | m | p " is equal to the MAC transmitted as part of the SaPDU and if the value of the direction flag is correct the user data are forwarded to the SaS-user. If an error occurs, e.g. the value of the direction flag is invalid, the MACs are not equal or there exists no cryptographic key for the underlying connection, the error management is informed and takes over further actions. Normally the evaluation starts with checking the MAC and only if it is correct is the information in the PDU used. The AU2 is an exception to this rule since some of the information inside the PDU is needed to calculate the MAC.

7.2.2.2.2 Peer Entity Authentication

7.2.2.2.2.1 Peer entity authentication is a safety procedure, which is used during connection set-up to compute the session key.

Procedure 3: Peer Entity Authentication (ETCS ID A, ETCS ID B, K_{AB})

Input: ETCS ID of A and B, authentication key (K_{AB}) shared between A and B.

Procedure: Peer Entity Authentication Protocol as defined in Figure 8

Output: In the non error case: successful authentication of A and B against each other, and a session key which A and B share

Error case: No safety connection between A and B, and the error management is informed

7.2.2.2.2.2 Peer entity authentication is performed during connection set-up. Its input parameters are the ETCS IDs of A and B which are authenticated against each other and the authentication key K_{AB} shared between A and B. The ETCS IDs of A and B are unique identifiers. The authentication key has been previously established between A and B using a logical or physical key establishment mechanism.

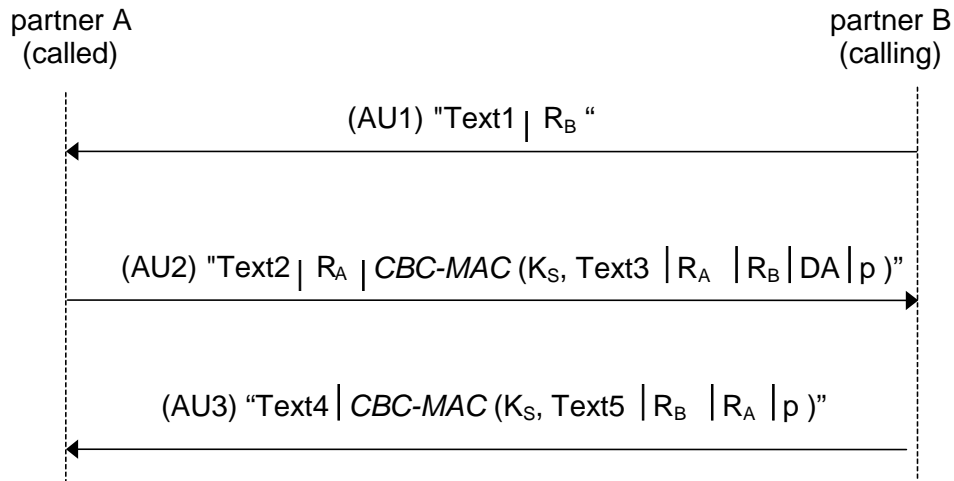

Figure 8 Sa-Protocol used for peer entity authentication and key generation

7.2.2.2.3 The initiator B of the connection set-up starts the safety association (SA-) protocol (see Figure 8) when requesting a transport connection. For the computation of the MAC it makes use of the message origin authentication procedure.

7.2.2.2.4 The initiator B transmits a random number R_B of length 64 bits which is generated by B as part of the first authentication message AU1SaPDU to his communication partner A. The random number R_B must be stored (dedicated to the link) before sending AU1SaPDU. After receiving this message, A generates as part of a second authentication message AU2 SaPDU, a random number R_A of length 64 bits, and a MAC computed over the text field text3, the two random numbers R_A and R_B, the identity of B (in this context B is the calling ETCS ID) and padding bits. For the computation of the MAC the session key K_S is computed using the session key generation function as described in section 7.2.2.2.4 and the parameters R_A, R_B and the authentication key K_{AB}. After receiving the message AU2 SaPDU and deriving the key K_S, B checks the correctness of the second authentication message received from A. Then, B computes a MAC over the text field text5, and the two random numbers R_A and R_B and transmits it as part of AU3 SaPDU to A. Finally, A checks AU3 SaPDU using the key K_S.

7.2.2.2.5 The fields:

- text1 = "ETY | MTI | DF | SA | SaF", where SA = calling ETCS ID,
- text2 = "ETY | MTI | DF | SA | SaF", where SA = responding ETCS ID,
- text3 = " l | DA | ETY | MTI | DF | SA | SaF",
 where DA = calling ETCS ID and SA = responding ETCS ID,
- text4 = " '000' | MTI | DF",
- text5 = " l | DA | '000' | MTI | DF", where DA = responding ETCS ID

consist of the ETCS ID type (ETY), the message type identifier (MTI) indicating an authentication SaPDU, the direction flag (DF), the source address (SA) (ETCS Identity

on 24 bits), the destination address (DA) (ETCS Identity on 24 bits), and the safety feature SaF.

7.2.2.2.2.6 If no error occurs the output of the peer entity authentication procedure is a successful authentication of A and B against each other and a session key, which is shared between A and B. If an error occurs during the peer entity authentication procedure, then the error management is informed and takes over. No safety connection is established between A and B in this case.

7.2.2.2.3 High priority information

7.2.2.2.3.1 The safety layer does not protect high priority data. The transfer of HP data is provided by the same transport connection as for normal data.

7.2.2.2.3.2 High priority data are transmitted unreliably and non-safely..

7.2.2.2.4 Cryptographic Keys

7.2.2.2.4.1 Note key management activities are the matter of other Unisig subsets (e.g. [Subset-038]).

7.2.2.2.4.2 The following table describes a three level key hierarchy.

Table 7 Extended key hierarchy

Level	Purpose
3 Transport keys (KTRANS)	Protection of management communication between KMC and RBC or train for establishment or revocation of authentication keys.
2 Authentication keys (KMAC)	Session key derivation in connection establishment.
1 Session keys (KSMAC)	Protection of data transfer between safety entities.

7.2.2.2.4.3 The level 3 keys (KTRANS) are used by the Key Management Centre to distribute level 2 keys or to change key assignments permanently, including revocation of keys and the introduction of new entities. The Key Management Centre shares a transport key with each entity.

7.2.2.2.4.4 The level 2 keys (KMAC; also referred as K_{AB}) are used for session key derivation. Authentication keys (KMAC keys) are level 2 keys, which have been assigned to particular entities. Two entities sharing a common level 2 key can set up a safety association.

7.2.2.2.4.5 The length of a level 2 key has to be 192 bits including parity bits, consisting of three 64-bit DES-keys for the single DES with modified MAC algorithm 3.

7.2.2.2.4.6 The level 1 keys (KSMAC; also referred as K_S) are derived during peer entity authentication by use of level 2 keys. They are used for the protection during connection set-up and data transfer, i.e. MAC computation, in a single session only.

They are connection specific and can only be shared by entities that share an authentication key (KMAC key).

7.2.2.2.4.7 Session keys (KSMAC) are referred to as one key (although consisting of three DES keys), which is used symmetrically, i.e. for both communication directions.

7.2.2.2.4.8 The length of a level 1 key is equal to 192 bits consisting of three 64-bit DES-keys.

7.2.2.2.4.9 Session keys are generated using the key derivation function as described in the section below. Both communication partners contribute with their 64-bit (pseudo) random number to the session key.

7.2.2.2.4.10 During the peer entity authentication a session key is derived between two communicating entities using the common authentication key $KMAC = (K_1, K_2, K_3)$ of these entities. One 192-bit KSMAC key shall be generated by the key derivation procedure. The derivation of the corresponding DES session keys is specified as follows between entities A and B:

7.2.2.2.4.11 The random numbers R_X ($X \in \{A, B\}$) are split into a left (R_X^L) and a right (R_X^R) 32-bit block:

$$R_A = R_A^L | R_A^R$$

$$R_B = R_B^L | R_B^R$$

7.2.2.2.4.12 The three 64-bit keys K_{S1} , K_{S2} and K_{S3} are calculated according the formulas:

$$K_{S1} := MAC (R_A^L | R_B^L, K_{AB}) = DES (K_3, DES^{-1}(K_2, DES(K_1, R_A^L | R_B^L)))$$

$$K_{S2} := MAC (R_A^R | R_B^R, K_{AB}) = DES (K_3, DES^{-1}(K_2, DES(K_1, R_A^R | R_B^R)))$$

$$K_{S3} := MAC (R_A^L | R_B^L, K'_{AB}) = DES (K_1, DES^{-1}(K_2, DES(K_3, R_A^L | R_B^L)))$$

where | is the concatenation operator

7.2.2.2.4.13 The length of a level 1 key is equal to 192 bits including parity bits. In order to get three 64-bit DES-keys for the single DES with modified MAC algorithm 3 from the three 64-bit session key generator outputs, each eighth bit of the 192 bits should be set to an odd-parity value as defined in the standard ANSI X3.92. However, setting the parity bits is an implementation matter where the key is internal to an equipment...

7.2.2.3 Communication procedures

7.2.2.3.1 Connection establishment

7.2.2.3.1.1 The following procedures are applied during connection establishment:

- The safety address information is passed to the CFM
- The peer entity authentication procedure is applied

7.2.2.3.2 Data transfer

7.2.2.3.2.1 The purpose of the data transfer phase is to permit the safe transfer of normal user data between the two SaS-users connected by the safety connection. The following procedures are applied:

- The message origin authentication procedure (refer to section 7.2.2.1.1) for normal data
- The service primitive's procedures provided by the transport layer.

7.2.2.3.3 Connection release

7.2.2.3.3.1 The safety connection is released by a SaS-user request, by a transport service provider action, or by an error handling action of the safety layer.

7.2.2.3.3.2 The authentication of the connection release phase is not required.

7.2.2.3.4 Error handling

7.2.2.3.4.1 Errors can occur during the connection set-up in the peer entity authentication, during the data transfer, and in the management of the safety protocol.

7.2.2.3.4.2 All errors have to be reported to the local SaS-user by the Sa-REPORT.indication or by the Sa-DISCONNECT.indication primitives.

7.2.2.3.4.3 Different error cases are handled by different strategies:

- Ignore the safety relevant event ;
- Optionally, ignore the safety relevant event and indicate the error to the SaS-user by **Sa-REPORT.indication** primitive;
- Release the safety connection, release of transport connection and indicate the error to the SaS-user by **Sa-DISCONNECT.indication** primitive.

7.2.2.3.4.4 It is the matter of the SaS user to react to the indicated event in a proper way.

7.2.2.3.4.5 NOTE: Registration of safety relevant errors is the matter of the application.

7.2.3 Time sequences

7.2.3.1 The flow of control information and user data is described in this chapter.

7.2.3.2 Connection establishment

7.2.3.2.1 When the Sa-CONNECT.request primitive requests a safety connection, the safety layer requests transport connection establishment by means of the service primitive **T-CONNECT.request**. This service primitive includes the first message of the peer entity authentication procedure (**AU1 SaPDU**) as user-data.

7.2.3.2.2 NOTE: AU1 and AU2 SaPDUs are exchanged by means of T-CONNECT primitives.

7.2.3.2.3 The called peer transport entity indicates the transport connection establishment request to its safety layer using the service primitive **T-CONNECT.indication**. The AU1

- SaPDU is forwarded to the safety layer in this service primitive as user-data. At the end of the first step the called safety layer entity evaluates the **AU1 SaPDU**.
- 7.2.3.2.4 If it is accepted, the safety entity responds to the TC establishment request by means of the service primitive **T-CONNECT.response**. It includes the second message of the peer entity authentication protocol (AU2 SaPDU) as user-data.
- 7.2.3.2.5 There is no QoS negotiation between peer entities.
- 7.2.3.2.6 AU1 and AU2 SaPDUs can be used for safety feature negotiation, corresponding to a version number. The initiating safety entity may request in the AU1 SaPDU a certain safety feature. The safety feature in the AU2 SaPDU will be the version accepted by the responding safety entity. If the initiating safety entity requests a safety feature not available, the safety feature in the AU2 SaPDU will be the default value.
- 7.2.3.2.7 On reception, the calling transport entity informs the safety layer of the successful establishment of the transport connection using the service primitive **T-CONNECT.confirmation**. The AU2 SaPDU is forwarded to the safety layer as user-data within this service primitive.
- 7.2.3.2.8 The safety entity then generates the **AU3 SaPDU** that contains the third message of the authentication protocol (auth3), as user-data. It uses the **T-DATA.request** service primitive to forward this message to the transport layer.
- 7.2.3.2.9 On reception, the transport entity uses the service primitive **T-DATA.indication** to forward the **AU3 SaPDU** to the safety layer as user-data. The safety entity evaluates the **AU3 SaPDU**.
- 7.2.3.2.10 In the case of a successful AU3 SaPDU evaluation, the safety entity forwards the service primitive **Sa-CONNECT.indication** to the safety user (i.e. ATP application).
- 7.2.3.2.11 If the safety user accepts the safety connection establishment request, it responds using the service primitive **Sa-CONNECT.response**.
- 7.2.3.2.12 The safety entity on the called side sends the authentication response message in the **AR SaPDU** by means of the **T-DATA.request** and **T-DATA.indication** primitives to its peer safety entity.
- 7.2.3.2.13 NOTE: The authentication response message is not required by the peer entity authentication procedure. It is added to provide an OSI-like confirmed service.
- 7.2.3.2.14 After a successful evaluation of this SaPDU including the authentication data, the safety entity informs the SaS-user that a safety connection is now successful established, using the service primitive **Sa-CONNECT.confirmation**.
- 7.2.3.2.15 When the **Sa-CONNECT.confirmation** is received, the calling SaS user is able to send data to the peer user through the safe connection. The called SaS user is able to request the data transfer immediately after the Sa-CONNECT.response primitive.

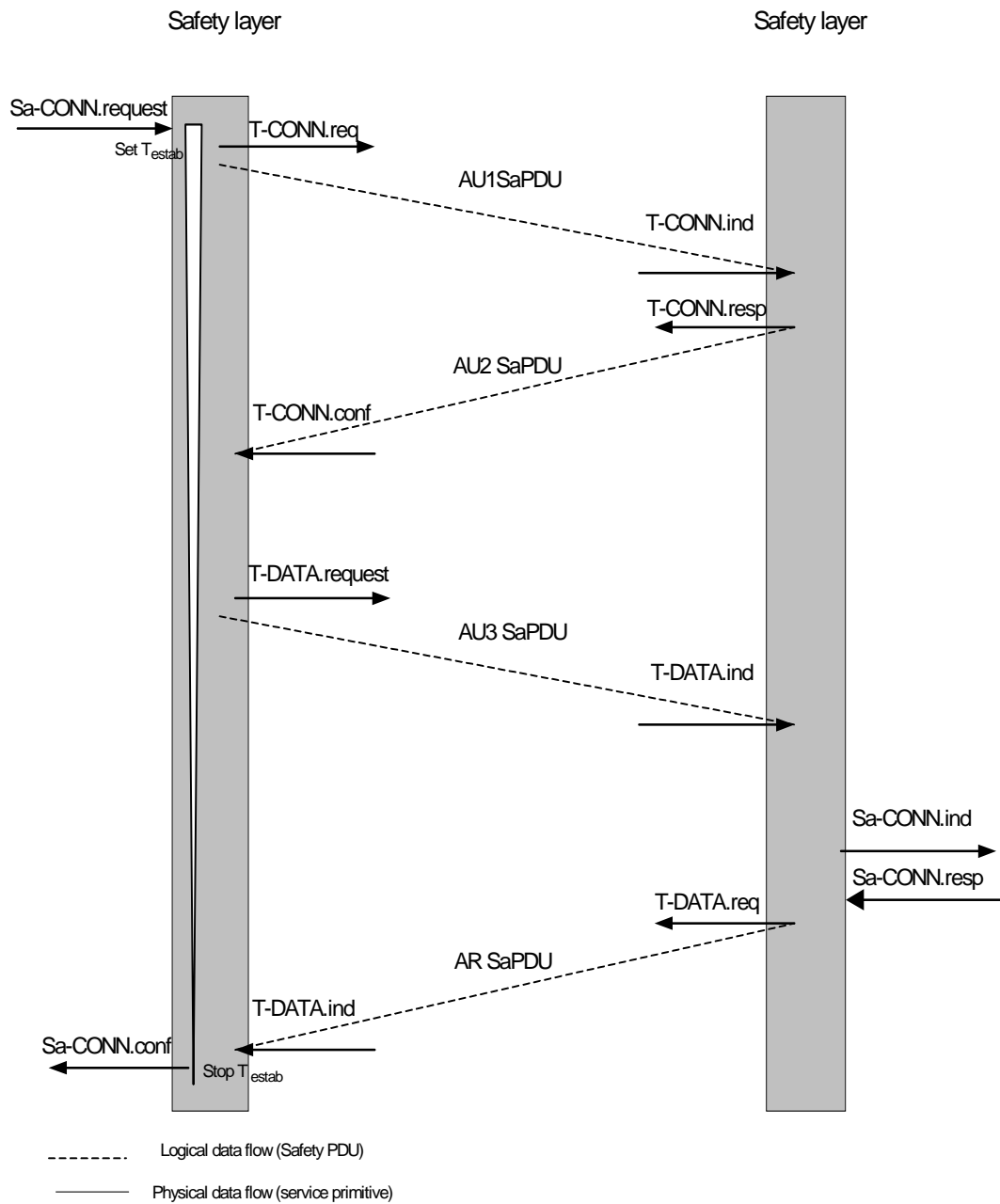

Figure 9 Time sequence during connection establishment

7.2.3.2.16 The maximum connection establishment delay timer is used for detecting unacceptable delay during the connection establishment. The timer T_{estab} is set after reception of the **Sa-CONNECT.request** and is stopped before generation of the **Sa-CONNECT.confirmation**. In the case of time-out, a **Sa-DISCONNECT.indication** is generated including a proper reason. All **SaPDUs** will be ignored if received after the timer elapses.

7.2.3.2.17 The safety layer entity of an RBC must be able to handle the establishment of more than one safe connection at the same time. The onboard system must be able to have contact with 2 entities at the same time to allow seamless area change. Other situations may also require this feature.

7.2.3.3 Data Transfer

7.2.3.3.1 The protocol sequence of Figure 9 shows how data are transmitted by the SFM. The user data of a **Sa-DATA.request** primitive are included in the user data part of the **DT SaPDU**. The transfer of the DT SaPDU uses the transport service primitives **T-DATA.request** and **T-DATA.indication**.

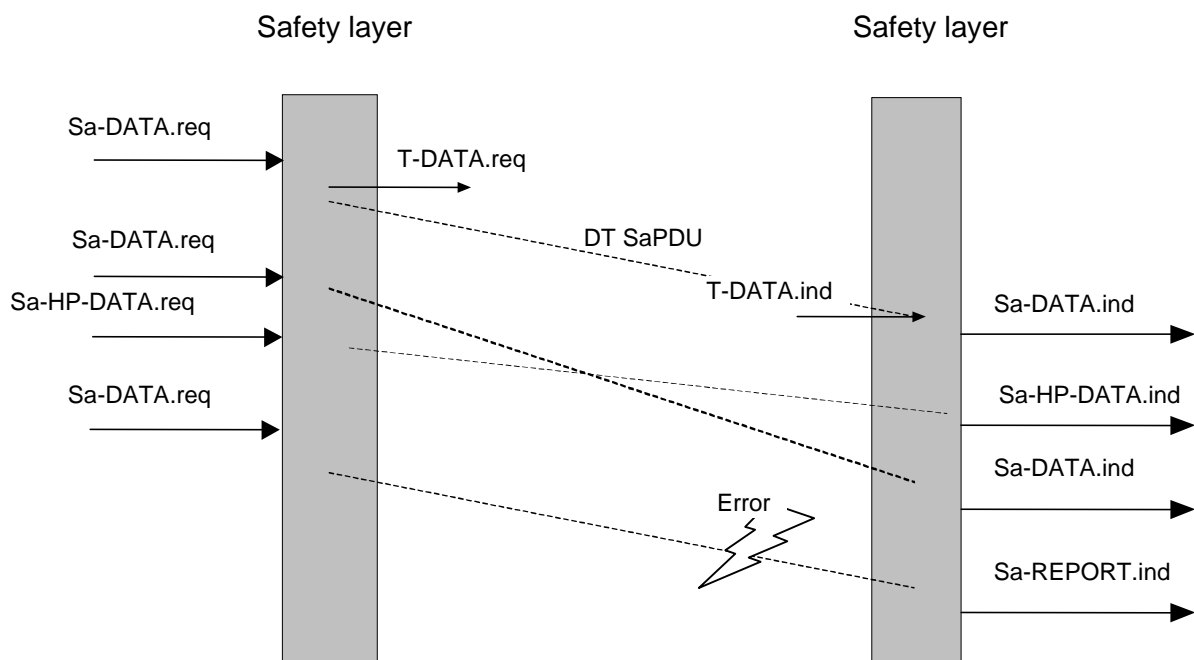

Figure 10 Time sequence during data transfer (example)

7.2.3.3.2 The receiving safety layer entity:

- Checks the format of the SaPDU and the protocol control information
- Checks the MAC and integrity

7.2.3.3.3 The user data of a safe transmitted **DT SaPDU** are included in a **Sa-DATA.indication** primitive.

7.2.3.3.4 The transfer of high priority data is similar to that of normal data transfer.

7.2.3.3.5 In the case of a safety problem with the **DT SaPDU**, the **Sa-REPORT.indication** or the **Sa-DISCONNECT.indication** indicates this to the safety user.

7.2.3.4 Connection Release

7.2.3.4.1 The connection release is requested by means of the primitive **Sa-DISCONNECT.request**. The safety layer then requests the transport layer to

disconnect by means of **T-DISCONNECT.request**. The DI SaPDU is included in the user data of the T-DISCONNECT.request primitive (Figure 11).

- 7.2.3.4.2 Peer entities are informed about the disconnection by means of **T-DISCONNECT.indication** and **Sa-DISCONNECT.indication**.
- 7.2.3.4.3 Authentication of the connection release phase is not required.
- 7.2.3.4.4 In the case of a service provider or safety layer originated connection release, this release will be indicated to both SaS-users by **Sa-DISCONNECT.indication** containing the respective reason.
- 7.2.3.4.5 NOTE: In the case of a service-provider-caused release, SaPDUs can be lost due to corrupted TPDU.

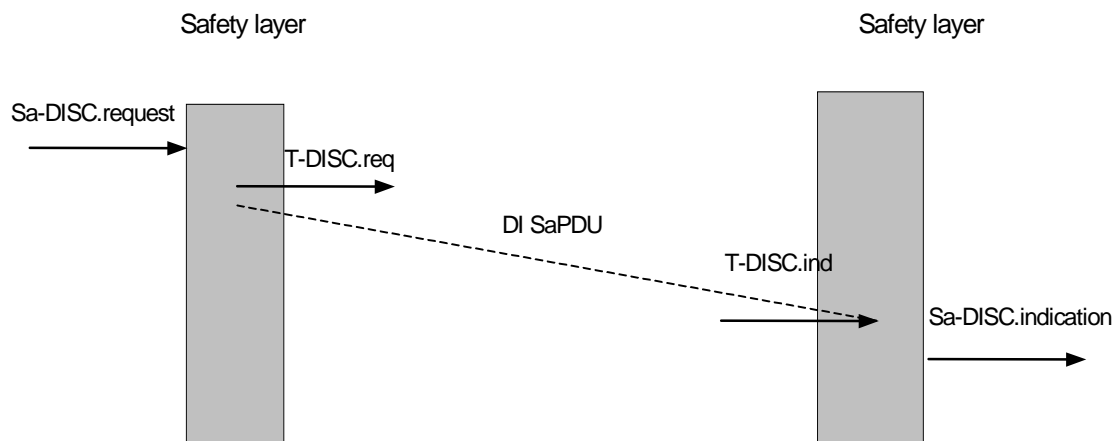

Figure 11 Time sequence during connection release (SaS-user originated)

7.2.4 Structure and encoding of safety PDUs

7.2.4.1 General structure of SaPDUs

7.2.4.1.1 All the safety protocol data units (SaPDUs) shall contain an integral number of octets. The octets in a SaPDU are numbered starting from 1 and increasing in the order they are put into a SaPDU. The bits in an octet are numbered from 8 to 1, where bit 1 is the lowest order bit. If a SaPDU field uses more than one octet, bit 8 of the first octet contains the most significant bit of the field.

7.2.4.1.2 When consecutive octets are used to represent a binary number, the lower octet number has the most significant value.

7.2.4.1.3 The meaning of an indication "Reserved" is:

- The transmitting side has to insert the value "0";
- The receiving side has to interpret as "Don't care".

7.2.4.1.4 SaPDUs shall contain, in the following order:

- The header (consisting of the message type identifier field and the direction flag field);
- The data field (if present);
- The MAC field (if applicable).

7.2.4.1.5 The structure is illustrated in Table 8.

Table 8 Structure of a Safety PDU

Header Type + Direction	Data	MAC Not used for AU1 or DI SaPDU
1 Octet	Variable	8 octets

7.2.4.1.6 Message Type Identifier field

7.2.4.1.6.1 The message type identifier (MTI) specifies the type of the SaPDU (Table 9).

Table 9 Safety PDUs

Type	Type Code	Name
AU1 SaPDU	0001	First authentication SaPDU (AU1)
AU2 SaPDU	0010	Second authentication SaPDU (AU2)
AU3 SaPDU	0011	Third authentication SaPDU (AU3)
AR SaPDU	1001	Response to third authentication SaPDU (AR)
DT SaPDU	0101	Data SaPDU (DT)
DI SaPDU	1000	Disconnect SaPDU (DI)

Note 1: HP SaPDU does not contain a header.

Note 2: Other SaPDUs are defined for key management (refer to Key Management FIS).

7.2.4.1.7 Direction flag field

7.2.4.1.7.1 The direction flag is used as a protection against reflection attacks. It is initialised during connection set-up. Its value is zero when the connection initiator transmits a message and one when the responder of the connection transmits a message.

7.2.4.1.7.2 The message type identifier field and direction flag field together make up the header.

7.2.4.1.8 MAC field

7.2.4.1.8.1 The MAC computation is specified in the relevant section.

7.2.4.2 Connection establishment PDU

7.2.4.2.1 AU1 and AU2 SaPDUs are exchanged by means of T-CONNECT primitives.

7.2.4.2.2 The **first authentication SaPDU** consists of the fields specified in Table 10.

Table 10 Structure of the AU1 SaPDU

Octet	Bit 8 7 6 5 4 3 2 1	Field name	Field
1	xxx. 001. 010. 011. 101. 110.	"ETY"	ETCS ID type of the field "SA" RBC Engine Reserved for Balise Key management entity Interlocking related entity Not required for Class 1
1	...0 001.	"MTI"	Message Type Identifier: AU1
10	"DF"	Direction Flag: '0'B indicates the direction to the responder
2 3 4	xxxx xxxx xxxx xxxx xxxx xxxx	"SA"	Calling ETCS ID
5	Xxxx xxxx 0000 0001	"SaF"	Requested Safety feature Single DES with modified MAC algorithm 3 All other values are reserved
6 ... 13	Xxxx xxxx ... xxxx xxxx	"R _B "	Random number R _B of the first authentication message

7.2.4.2.3 The **second authentication SaPDU** consists of the fields specified in Table 11.

Table 11 Structure of the AU2 SaPDU

Octet	Bit 8 7 6 5 4 3 2 1	Field name	Field
1	xxx. 000. 001. 010. 011. 101. 110.	"ETY"	ETCS ID type of the field "SA" Radio in-fill unit RBC Engine Reserved for Balise Key management entity Interlocking related entity Not required for Class 1
1	...0 010.	"MTI"	Message Type Identifier: AU2
11	"DF"	Direction Flag: '1'B indicates the direction to the initiator
2 3 4	xxxx xxxx xxxx xxxx xxxx xxxx	"SA"	Responding ETCS Id.
5	xxxx xxxx 0000 0001	"SaF"	Accepted safety features. Single DES with modified MAC algorithm 3 All other values are reserved.
6 ... 13	xxxx xxxx ... xxxx xxxx	"R _A "	Random number R _A of the second authentication message
14 ... 21	xxxx xxxx ... xxxx xxxx		MAC field. The MAC is computed according to the rules given in the peer entity and message origin authentication procedure.

7.2.4.2.4 The **third authentication SaPDU** consists of the fields specified in Table 12.

Table 12 Structure of the AU3 SaPDU

Octet	Bit 8 7 6 5 4 3 2 1	Field name	Field
1	0 0 0	"ETY"	Reserved
1	. . . 0 0 1 1 .	"MTI"	Message Type Identifier: AU3
1 0	"DF"	Direction Flag: '0'B indicates the direction to the responder
2 ... 9	xxxx xxxx . . . xxxx xxxx		MAC field. The MAC is computed according to the rules given in the peer entity and message origin authentication procedure

7.2.4.2.5 The **Authentication Response SaPDU** consists of the fields specified in Table 13.

Table 13 Structure of the AR SaPDU

Octet	Bit 8 7 6 5 4 3 2 1	Field name	Field
1	0 0 0	"ETY"	Reserved
1	. . . 1 0 0 1 .	"MTI"	Message Type Identifier: AR
1 1	"DF"	Direction Flag: '1'B indicates the direction to the initiator
2 ... 9	xxxx xxxx . . . xxxx xxxx		MAC field. the MAC computed according to the rules given in the peer entity and message origin authentication procedure

7.2.4.3 Data Transfer SaPDU

7.2.4.3.1 The **Data SaPDU** consists of the fields specified in Table 14.

Table 14 Structure of the DT SaPDU

Octet	Bit 8 7 6 5 4 3 2 1	Field name	Field
1	0 0 0		
1	. . . 0 1 0 1 .	"MTI"	Message Type Identifier: DT
1 x	"DF"	Direction Flag
2 ... 2+n-1	xxxx xxxx . . . xxxx xxxx		User data (length n>=1 octet): user data of the corresponding SaPDU
2+n ... 2+n+7	xxxx xxxx . . . xxxx xxxx		MAC field.

7.2.4.4 Disconnect SaPDU

7.2.4.4.1 The **Disconnect SaPDU** consists of the fields specified in Table 15.

Table 15 Structure of the DI SaPDU

Octet	Bit 8 7 6 5 4 3 2 1	Field name	Field
1	0 0 0		
1	. . . 1 0 0 0 .	"MTI"	Message Type Identifier: DI
1 x	"DF"	Direction flag.
2	xxxxx xxxxx		Reason field: the reason for the disconnect.
3	xxxxx xxxxx		SUB-reason field: the sub-reason for the disconnect.

7.2.4.5 High Priority SaPDU

7.2.4.5.1 The **High priority SaPDU** consists of the fields specified in Table 16. The High Priority SaPDU contains no header or MAC field.

Table 16 Structure of the HP SaPDU

Octet	Bit 8 7 6 5 4 3 2 1	Field
1 ... n	xxxxx xxxxx . . . xxxxx xxxxx	User data (length n>=1 octet): user data of the corresponding SaPDU

7.2.5 State table

7.2.5.1 The state transition diagram and the state table are symmetrical for on-board and trackside SFM.

7.2.5.2 General

7.2.5.2.1 This section describes the safety protocol in terms of state tables. The state tables show the state of a safety layer entity, the events that occur in the protocol, the actions taken and the resultant state. The state tables are conceptual and do not impose any constraints on the implementation.

7.2.5.2.2 The state tables also define the mapping between safety service primitives and protocol events that safety service users (SaS users) can expect.

7.2.5.2.3 The state tables do not necessarily describe all possible combinations of sequences of events at safety and transport service boundary, nor do they describe the exact mapping between SaPDUs and TSDUs.

7.2.5.3 Conventions

7.2.5.3.1 States are represented in the tables by their abbreviation, as defined in Table 17.

Table 17 States

State abbreviation	State name
WFTC	Wait for transport connection
WFAR	Wait for the authentication response SaPDU
DATA	Safety connection is opened and ready for data transfer
WFAU3	Wait for the third authentication message
WFRESP	Wait for Sa-CONNECT.response
IDLE	Safety connection is closed or does not exist

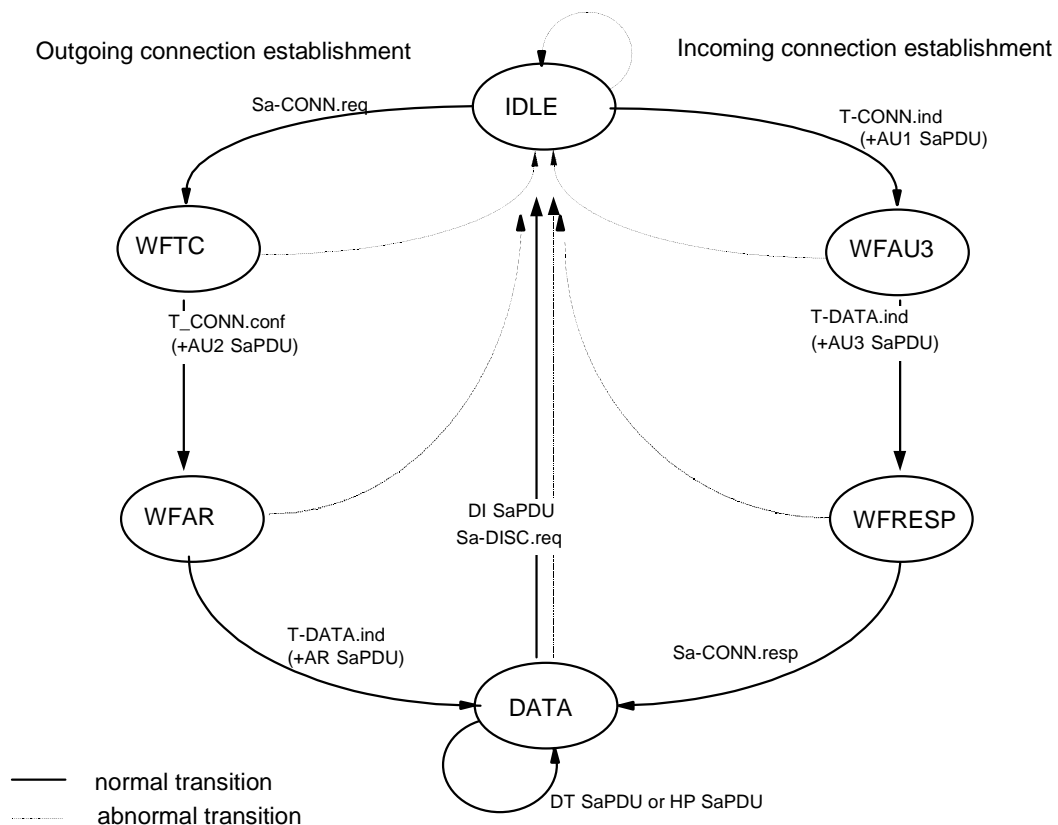

Figure 12 State transition diagram of the safety layer entity

7.2.5.3.2 The intersection of each state and incoming event that is invalid is left blank in the state tables. The action to be taken in this case shall be one of the following:

- for an event related to the safety service (i.e. coming from the SaS-user), take no action;
- for an event related to a received SaPDU, follow the procedure for treatment of protocol errors if the state of the supporting transport connection makes it possible;
- for an event falling into neither of the above categories (including those which are impossible by the definition of the behaviour of the safety entity or SaS-provider), take no action.

7.2.5.3.3 At each intersection of state and event which is valid the state tables specify an action which may include one of the following:

- one action constituted of a list of any number of outgoing events (none, one, or more) given by their abbreviation defined in Table 19 followed by certain special actions (see Table 21), if applicable, and the abbreviation of the resultant state (see Table 17);
- conditional actions separated by a semi-colon (;). Each conditional action contains a predicate followed by a colon (:) and by an action as defined in a). The predicates are Boolean expressions given by their abbreviation and defined in Table 20. Only the action corresponding to the true predicate shall be taken.

7.2.5.3.4 There is a unique association between the safety connection and the transport connection used. The mapping of the local references (SaCEPID and TCEPID) is a matter of the implementation.

7.2.5.3.5 Table 18 specifies the names and abbreviation of the incoming events classified as event originated by TS-provider, SaS-user or safety layer entity.

Table 18 Incoming events

Abbreviation	Origin of event	Name
Sa-CONN.req	SaS-user	Sa-CONNECT.request primitive
Sa-CONN.resp	SaS-user	Sa-CONNECT.response primitive
Sa-DATA.req	SaS-user	Sa-DATA.request primitive
Sa-HP-Data.req	SaS-user	Sa-HP-DATA.request primitive
Sa-DISC.req	SaS-user	Sa-DISCONNECT.request primitive
T-DISC.ind	TS-provider	T-DISCONNECT.indication primitive
T-CONN.ind (+AU1SaPDU)	TS-provider	T-CONNECT.indication primitive
T-CONN.conf (+AU2SaPDU)	TS-provider	T-CONNECT.confirmation primitive
AU3 SaPDU	Safety layer entity	Authentication 3 SaPDU
AR SaPDU	Safety layer entity	Authentication response SaPDU
DI SaPDU	Safety layer entity	Disconnect Request SaPDU
DT SaPDU	Safety layer entity	Data SaPDU
HP SaPDU	Safety layer entity	High priority data SaPDU
time-out Testab	Safety layer entity	Connection establishment timer

7.2.5.3.6 Table 19 specifies the names and abbreviations of the outgoing events classified as event originated by SaS-provider, TS-user or safety layer entity .

Table 19 Outgoing events

Abbreviation	Origin of event	Name
Sa-CONN.ind	SaS-provider	Sa-CONNECT.indication primitive
Sa-CONN.conf	SaS-provider	Sa-CONNECT.confirmationprimitive
Sa-DATA.ind	SaS-provider	Sa-DATA.indication primitive
Sa-HP-DATA.ind	SaS-provider	Sa-HP-DATA.indication primitive
Sa-DISC.ind	SaS-provider	Sa-DISCONNECT.indication primitive
Sa-REPORT.ind	SaS-provider	Sa-REPORT.indication primitive
T-CONN.req (+AU1SaPDU)	TS-user	T-CONNECT.request primitive
T-CONN.resp (+AU2SaPDU)	TS-user	T-CONNECT.response primitive
T-DISC.req	TS-user	T-DISCONNECT.request primitive
AU3 SaPDU	Safety layer entity	Authentication 3 SaPDU
AR SaPDU	Safety layer entity	Authentication response SaPDU
DI SaPDU	Safety layer entity	Disconnect Request SaPDU
DT SaPDU	Safety layer entity	Data SaPDU
HP SaPDU	Safety layer entity	High Priority data SaPDU

Table 20 Predicates

Name	Description
Pre0	Sa-CONNECT. request unacceptable <ul style="list-style-type: none"> at least the following parameter is required : application type application type error
Pre1	Unacceptable T-CONNECT.indication, <ul style="list-style-type: none"> at least the following parameters are required : application type, user data application type error Unacceptable AU1 SaPDU <ul style="list-style-type: none"> AU1 SaPDU format error ETY,MTI,DF or SaF error KMAC not available
Pre2	Unacceptable T-CONNECT.confirmation, <ul style="list-style-type: none"> at least the following parameter is required: user data Unacceptable AU2 SaPDU <ul style="list-style-type: none"> AU2 SaPDU format error <ul style="list-style-type: none"> ETY,MTI,DF or SaF error KMAC not available MAC error
Pre3	Unacceptable AU3 SaPDU <ul style="list-style-type: none"> AU3 SaPDU format error <ul style="list-style-type: none"> ETY, MTI or DF error MAC error
Pre4	Unacceptable AR SaPDU <ul style="list-style-type: none"> AR SaPDU format error

© This document is the property of

ALCATEL * ALSTOM * ANSALDO SIGNAL * BOMBARDIER * INVENSYS RAIL * SIEMENS

	<ul style="list-style-type: none"> • ETY, MTI or DF error • MAC error
Pre 5	Erroneous SaPDU <ul style="list-style-type: none"> • MAC error of DT SaPDU
Pre6	Unacceptable DT SaPDU <ul style="list-style-type: none"> • DT SaPDU length error • MTI error • DF error (condition: no MAC error)

7.2.5.3.7 The state table specifies the precise protocol to provide interoperability, but does not specify the implementation of the protocol.

Table 21 Timer definitions

Symbol	Name	Definition
T _{estab}	Connection establishment time	An upper bound for the time after which the local safety entity will initiate the error handling procedure, if it does not receive the authentication response message.

Table 22 Integrity actions

Abbreviation	Action
a5	Set timer T _{estab}
a6	Stop timer T _{estab}
a19	Stop all timers; reset all counters.

Table 23 State table

State Event	IDLE	WFTC	WFAR	DATA	WFAU3	WFRESP
Sa-CONN.req	Pre0: Sa-DISC.ind, IDLE; not Pre0: T-CONN.req (AU1 SaPDU), a5, WFTC					
Sa-CONN.resp						AR SaPDU, DATA
Sa-DATA.req				DT SaPDU, DATA		
Sa-HP-DATA.req				HP SaPDU, DATA		
Sa-DISC.req		T-DISC.req a19, IDLE Note1	T-DISC.req (+DI SaPDU), a19, IDLE	T-DISC.req (+DI SaPDU), a19, IDLE		T-DISC.req (+DI SaPDU) a19, IDLE

State Event	IDLE	WFTC	WFAR	DATA	WFAU3	WFRESP
T-CONN.ind (+AU1SaPDU)	Pre1:T-DISC.req (+DI SaPDU), IDLE; not Pre1: T-CONN.resp (+AU2 SaPDU) WFAU3					
T-CONN.conf (+AU2SaPDU)		Pre2: Sa-DISC.ind, T-DISC.req, a19, IDLE Note1 not Pre2: AU3 SaPDU, WFAR				
T-DISC.ind or T-DISC.ind (+DI SaPDU)		Sa-DISC.ind, a19, IDLE	Sa-DISC.ind, a19, IDLE	Sa-DISC.ind a19, IDLE	a19, IDLE	Sa-DISC.ind a19, IDLE
AU3 SaPDU					Pre3: T-DISC.req (+DI SaPDU), a19, IDLE not Pre3: Sa-CONN.ind, WFRESP	
AR SaPDU			not Pre4: Sa-CONN.conf, a6, DATA; Pre4: Sa-DISC.ind, T-DISC.req (+DI SaPDU), a19, IDLE			
DT SaPDU				not Pre5 and not Pre6: Sa-DATA.ind, DATA; Pre5: Sa-REPORT.ind, DATA Note 3 Pre6: Sa-DISC.ind, T-DISC.req (+DI SaPDU), a19, IDLE		
HP SaPDU				Sa-HP-DATA.ind, DATA Note 2		
time-out T _{estab}		Sa-DISC.ind, T-DISC.req, a19, IDLE Note1	Sa-DISC.ind, T-DISC.req (+DI SaPDU), a19, IDLE			
Notes: 1. The DI SaPDU is not contained. 2. HP SaPDUs by-pass the safety procedures. 3. Optional Sa-REPORT.indication delivered to the SaS user, if supported.						

7.3 Safety Protocol Management

7.3.1 Functions of the Safety Protocol Management

- 7.3.1.1 The safety protocol management defines the configuration management needed to handle the parameters of the safety protocol, and the supervision and diagnostics of the safety protocol. The main emphasis is placed on achieving technical interoperability between the on-board unit and the trackside unit with respect to the safety protocol management.
- 7.3.1.2 All details of the specification, which are implementation dependent like the generation, storage, and deletion of keys, or error logging are not covered by this specification.
- 7.3.1.3 The over-the-air updating of keys etc. are possible using management SaPDU's. The use of management SaPDU's is optional. Further information can be found in annex C.
- 7.3.1.4 The management of the safety layer protocol is embedded in the SFM sub-system. Parts of it are clearly safety related and have to be realised in a safe environment whereas other parts are not. The details depend on the particular implementation and are not covered by this specification.

7.3.2 Configuration Management

- 7.3.2.1 The configuration management defines the parameters needed for the execution of the safety protocol and its management, and the functions to manage them.
- 7.3.2.2 Address Parameters
- 7.3.2.2.1 The safety protocol uses the ETCS Identities for addressing. The ETCS Identities are unique within the scope of the respective ETCS ID type. The ETCS ID together with the application type identifies the safety service user.

Table 24 ETCS Identity (see Unisig SRS [Subset-026] chapter 7)

ETCS ID	Range of values			Description
	Octet1	Octet2	Octet3	
	8765 4321	8765 4321	8765 4321	
ETCS ID of on-board unit	tttt	tttt	tttt	tttt
ETCS ID of RBC	cccc	cccc	ccrr	rrrr
	rrrr	rrrr	rrrr	rrrr
11	1111
	1111	1111	1111	1111
ETCS ID of radio in-fill unit (ETCS level1)	cccc	cccc	ccrr	rrrr
	rrrr	rrrr	rrrr	rrrr
11	1111
	1111	1111	1111	1111

© This document is the property of

ALCATEL * ALSTOM * ANSALDO SIGNAL * BOMBARDIER * INVENSYS RAIL * SIEMENS

ETCS ID	Range of values			Description
	Octet1	Octet2	Octet3	
	8765 4321	8765 4321	8765 4321	
ETCS ID of KM entity	c...c	c...c	cckk kkkk kkkk kkkk	Country or region ID Key management entity ID

7.3.2.2.2 Note: The definition of ETCS ID structure and values is out of scope for this FIS.

7.3.2.2.3 Identities are used during the connection set-up to compute the corresponding safety association, i.e. the ETCS IDs are relevant for the execution of the safety procedure peer entity authentication.

7.3.2.2.4 A safety association is defined between two ETCS-Identities as soon as they share a common authentication key to set up a safe connection. Besides the authentication key, also the other parameters have to be defined for every safety association.

7.3.2.2.5 Additionally, the transport service access points (TSAPs) are used by the safety layer to access the transport layer.

7.3.2.3 Timer Parameter

7.3.2.3.1 The parameter maximum connection establishment delay is used for detecting unacceptable delay during the connection establishment.

Table 25 Safety layer timer parameter

Parameter	Symbol	Applied value	Comments
Maximum connection establishment delay	T _{estab}	40 s	Depends on the communication network

7.3.3 Supervision and Diagnostics

7.3.3.1 The supervision and diagnostics describes the error management of the safety layer and the monitoring and auditing of safety relevant events.

7.3.3.2 The error management defines the error handling, and the error reporting to the application layer, as far as it is needed for interoperability reasons.

7.3.3.3 NOTE: Error logging by SFM is not required for Class 1. It has to be done by the application, if required.

7.3.3.4 Error Reporting

7.3.3.4.1 All safety relevant errors that occur in the safety layer which are treated by the application have to be reported to the application immediately after their occurrence. Errors handled internally by the safety layer management, may be reported to the application but do not have to be. There are two possibilities for reporting errors to the application:

- If the error leads to a mandatory connection release, it can be reported to the application using the service primitive **Sa-DISCONNECT.indication**. The application is informed about the type of the error using the parameter **disconnect reason**.
- If the error is only treated internally by the safety layer management or does not lead to a mandatory connection release it can be reported optionally to the application using the service primitive **Sa-REPORT.indication**. The application is informed about the type of the error by the parameter tuple (**reason code, sub-reason code**).

7.3.3.5 Error Handling

7.3.3.5.1 If an error occurs in the safety layer the error management has to undertake the following actions depending on the reason and sub-reason of this error. One indicated reason may be caused by different sub-reasons which may be detected by symptoms requiring different error handling actions. The tuples (reason code, sub-reason code) are applied in the **Sa-DISCONNECT.indication** and **Sa-REPORT.indication** to indicate the type of the error to the user of the service.

7.3.3.5.2 An error handling action implies the sending of T-DISCONNECT.request (+DI SaPDU), if requested according to state table .

7.3.3.5.3 **Class 1 requirement:** When error information is transmitted to the application by **Sa-DISCONNECT.indication**, it is the responsibility of the application for further action.

7.3.3.5.4 The error indication provided by T-DISCONNECT.indication shall be handled by the safety layer:

- When reason = Network error is received, this error is forwarded to the application.
- The reason = Called TS user not available should not be received from the Communication Layer, as the ATP is supposed to be supported by the peer entity. However, if this reason is received by the safety layer, the application will be informed.

Table 26 Normal release

Reason Code	Sub-reason Code	Description	Error handling action
0		Normal release requested by peer SFM user	Sa-DISCONNECT.indication

Table 27 Sub-reasons for the reason 'No transport service available'

Reason Code	Sub-reason Code	Description	Error handling action
1	1	Network error	Sa-DISCONNECT.indication The application should try to establish

© This document is the property of

ALCATEL * ALSTOM * ANSALDO SIGNAL * BOMBARDIER * INVENSYS RAIL * SIEMENS

Reason Code	Sub-reason Code	Description	Error handling action
			again the connection
1	2	Network resource not available	Sa-DISCONNECT.indication The application should try to establish again the connection with a lower quality of service parameter
1	3	Service or option is temporarily not available	Sa-DISCONNECT.indication The application should try to establish again the connection with a modified parameter .
1	5	Reason unknown	Sa-DISCONNECT.indication
1	6	Called TS user not available	Sa-DISCONNECT.indication The application should try to establish again the connection with short dialling code
1	8	No mobile station has been registered	Sa-DISCONNECT.indication The application should re-try network registration
NOTE: 1.The sub-reason is equivalent to the reason of T-DISCONNECT.indication.			
2. Sub-reasons are a matter of implementation. The error codes are not transmitted via the air interface			

Table 28 Sub-reasons for the reason 'Missing parameter or invalid parameter value'

Reason Code	Sub-reason Code	Description	Error handling action
3	2	Missing authentication key	Sa-DISCONNECT.indication.
3	3	Other problem related to the key management (e.g. loss of session key).	Sa-DISCONNECT.indication. The SFM user can set-up a new connection.
3	29	Requested safety feature is not supported	Sa-DISCONNECT.indication

Table 29 Sub-reasons for the reason 'Invalid MAC'

Reason Code	Sub-reason Code	Description	Error handling action
4	1	MAC error	Sa-REPORT.indication
4	2	MAC error in AU2 SaPDU.	Sa-DISCONNECT.indication.
4	3	MAC error in AU3 SaPDU	T-DISCONNECT.request.
4	4	MAC error in AR SaPDU	Sa-DISCONNECT.indication

Table 30 Sub-reasons for the error type 'failure in sequence integrity'

Reason Code	Sub-reason Code	Description	Error handling action
5	1	Replay of authentication message (AU1 SaPDU, AU2 SaPDU, AU3 SaPDU, AR SaPDU) after connection establishment. Error code is used, if the error is not covered by reason code 9.	Sa-DISCONNECT.indication

7.3.3.5.5 Error type: Failure in the direction flag

7.3.3.5.6 This check is performed after the check of the MAC (not in the case of AU1 or DI SaPDU). If there is a transmission error that affects the flag, the MAC will detect this, and the reaction will be as in table 29. If the MAC is correct, but the flag is not correct, there will be a SA-DISCONNECT.indication.

Table 31 Sub-reasons for the reason 'Failure in the direction flag'

Reason Code	Sub-reason Code	Description	Error handling action
6	1	Value of direction flag '0' instead of '1'	Sa-DISCONNECT.indication The application is supposed to request a new connection establishment.
6	2	Value of direction flag '1' instead of '0'	Sa-DISCONNECT.indication (after previous Sa-CONNECT.indication) The application is supposed to request a new connection establishment.

Table 32 Sub-reasons for the reason 'Time out at connection establishment'

Reason Code	Sub-reason Code	Description	Error handling action
7	3	Time out of T_{estab} without receiving the AR SaPDU	Sa-DISCONNECT.indication The application is supposed to request a new connection establishment.

Table 33 Sub-reasons for the reason 'Invalid SaPDU field'

Reason Code	Sub-reason Code	Description	Error handling action
8	1	Invalid information field	Rejection of SaPDU
8	4	Invalid responding ETCS Id in AU2, i.e. ETCS-Identity does not correspond to an acceptable ETCS ID. ⁴	Sa-DISCONNECT.indication

⁴ If there is a call establishment request to an unknown RBC any one of the possible RBCs can be an expected one.

Reason Code	Sub-reason Code	Description	Error handling action
8	5	Invalid AU1 SaPDU : the header indicates a AU1 SaPDU, but the rest of the Sa PDU does not match with the structure of an AU1 SaPDU.	Rejection of SaPDU

Table 34 Sub-reasons for the reason 'Failure in sequence of the SaPDUs during connection set-up'

Reason Code	Sub-reason Code	Description	Error handling action
9	1	Transmission of AU1 SaPDU but a message different from AU2 SaPDU is obtained.	Sa-DISCONNECT.indication
9	2	Transmission of AU2 SaPDU but a message different from AU3 SaPDU is obtained.	T-DISCONNECT.request
9	3	Transmission of AU3 SaPDU but a message different from AR SAPDU is obtained.	Sa-DISCONNECT.indication

Table 35 Sub-reasons for the reason ' SaPDU length error '

Reason Code	Sub-reason Code	Description	Error handling action
10	1	AU1 SaPDU length error	Rejection of AU1 SaPDU
10	2	AU2 SaPDU length error	Sa-DISCONNECT.indication
10	3	AU3 SaPDU length error	T-DISCONNECT.request
10	5	DT SaPDU length error	Sa-DISCONNECT.indication
10	8	AR SaPDU length error	Sa-DISCONNECT.indication

7.3.3.5.7 The code 127 (unknown) has to be used, when

- no proper reason code or subreason code can be selected
- the reason code or subreason code is undefined

7.3.3.5.8 The reason codes 11-126 are reserved for future use. The reason codes 128-255 are reserved for national use/implementation specific use. For these reason codes the subreason codes (0...126, 128...255) are also reserved for national use / implementation specific use.

8. COMMUNICATION FUNCTIONAL MODULE

8.0.0.1 This chapter specifies the Communication Functional Module (CFM), its services, and the protocol stack based on circuit switched bearer services of GSM PLMNs and fixed networks. The CFM covers the OSI layers 4 (transport layer), 3 (network layer), and 2 (data link layer).

8.0.0.2 NOTE: The service interface is not mandatory for Class 1. The service primitives of Annex B describe the interface at a functional level only.

8.1 Service definition

8.1.1 Model of communication services

8.1.1.1 The communication services that the RCS Communication Functional Module offers to its users (Safe Functional Module and optionally non-safe users) are based on the services provided by the transport layer of ISO/OSI reference model [X.214]. These services concern:

- Transport connection establishment/release
- Reliable data transmission
- Transparent data transmission.

8.1.1.2 Additionally, the transmission of high priority data is provided.

8.1.1.3 A communication functional module offers also reliability enhancement of the transmission channel.

8.1.1.4 A CFM entity communicates with its users (CFM user⁵) through one or more Transport Service Access Point (TSAP) by means of transport service primitives. The CFM entities supporting a transport connection exchange Transport Protocol Data Units (TPDU) for normal data use the service of the lower layers, through the respective Service Access Points.

8.1.1.5 The service for high priority data is described in section 8.1.5.

8.1.1.6 Optionally, more than one transport connection per physical channel can be supported by a CFM. This option is not required for ETCS level 1 radio in-fill unit.

8.1.1.7 Figure 13 contains a model only. It does not restrict any implementations.

8.1.2 Connection establishment

8.1.2.1 The process of establishing a transport connection is initiated at the time where the communication service user requests a connection set up to Communication

⁵ CFM user is applied to indicate a service user of the CFM. The correct OSI term would be TS user.

Functional Module. This service is accessed through the service primitive T-CONNECT.request with its associated parameters at the TSAP. At the time of connection set up request, the user has the possibility to specify its needs by means QoS class and of the application type to be served.

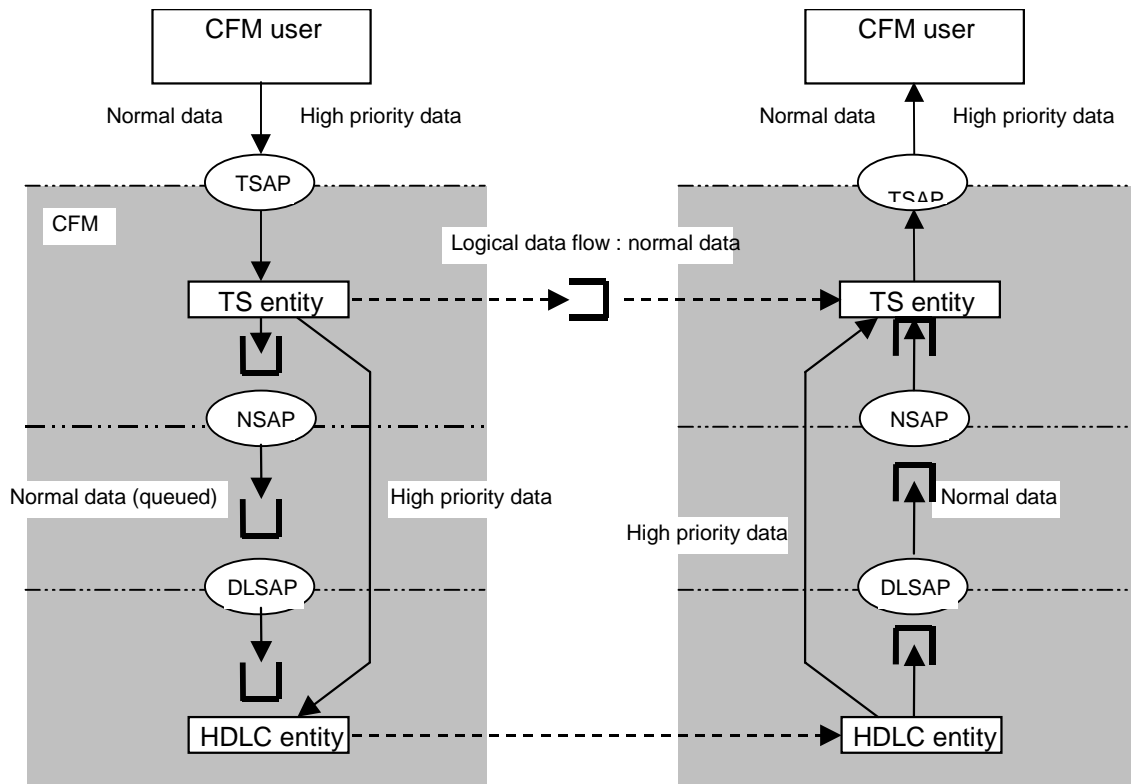

 Symbol of a queue

Figure 13 Model of communication service

8.1.2.2 The communication functional module evaluates the value of the QoS class and the application type. The associated set of quality of service parameter values will be used

- to select the proper bearer service for physical connection establishment, when this connection does not yet exist;
- optionally, to select the scheduling features of transport layer multiplexing.

8.1.3 Data transfer

8.1.3.1 The data transfer service is provided after a successful transport connection set up. This service is accessed through the service primitive T-DATA.request with its associated parameters at the TSAP. The Communication Functional Module provides

transparent and reliable transfer of user data in both directions simultaneously, and hides to its users the way in which the data are handled internally.

8.1.4 Connection release

8.1.4.1 The transport connection release is provided by the Communication Functional Module through the use of the transport service primitive T-DISCONNECT.request, with its associated parameters. The connection release due to the Communication Functional Module, or caused by lower layers, will be indicated to the user.

8.1.5 High priority data

8.1.5.1 The HP data transfer service is an additional service provided for the transport connection with the application type ATP only (refer to section 8.2.4.6). HP data will be transferred with the highest transport priority in respect to data of all transport connections multiplexed on the same physical connection.

8.1.5.2 The service is accessed through the additional service primitive T-HP-DATA.request with its associated parameters at the TSAP.

8.1.5.3 Layers 4 and 3 protocol stack of the user plane is empty. Protocols which add headers are not specified. The user data are exchanged between the CFM users and layer 2. These data are immediately transmitted, by-passing any existing queues. All data will be routed to the peer CFM user, i.e. to the CFM user with the application type ATP. Multiplexing of HP data streams for different transport connections on the same physical connection is not possible.

8.1.5.4 NOTE: In the case of more than one receiving CFM users of application type ATP multiplexed on the same physical connection, the receiving CFM entity shall transfer the HP data to all CFM users of application type ATP.

8.1.5.5 Layer 2 sends/receives these data - and only this type of data - as UI-frames. In the case of erroneous or lost UI frames, layer 2 does not repeat the transmission. Acknowledgement and repetition shall be provided if required by the CFM users.

8.1.5.6 Segmenting and reassembling of the user data is not possible. The user data length is restricted to the length of the data field of the UI frame.

8.1.5.7 **Class 1 requirement:** It is **mandatory** to transfer HP data from RBC to the train.

8.1.6 Quality of Service

8.1.6.1 The term Quality of Service (QoS) refers to certain characteristics of a transport connection as observed between the endpoints.

8.1.6.2 The QoS parameters give transport service (TS) users a method of specifying their needs, and give the TS provider a basis for selection of the protocol or for requesting services of lower layers. The QoS is normally negotiated between the TS users and the

TS provider on a per transport connection basis, using the T-CONNECT request, indication, response, and confirm TS primitives. The negotiated QoS values then apply throughout the lifetime of the transport connection. For the purposes of this FIS for the use in the transport protocol the values for all parameters are fixed for a given application type, in which case QoS negotiation on a per transport connection basis is restricted to local negotiation between the requesting side and its local transport providing entity.

8.1.6.3 There is no guarantee that the originally negotiated QoS will be maintained throughout the transport connection lifetime. The Transport Service provider does not explicitly signal changes in QoS.

8.1.6.4 Possible choices and default values for each parameter will normally be specified at the time of initial TS provider installation.

8.2 Communication protocols

8.2.1 Introduction

8.2.1.1 This section provides a precise specification of the communication protocols of the user channel. The protocol specifications are described layer by layer as delta specifications to existing standards.

8.2.2 Data Link Layer

8.2.2.1 According to the OSI reference model the reliable transfer of data is provided by the data link layer. The data link layer of the B/B_m-channel provides functional and procedural means to establish, maintain, and release connections and to transfer data. It will detect and correct data transfer errors, which may occur in the physical layer.

8.2.2.2 The protocol of layer 2 (DTE-DTE communication) will transmit data according to the sequence of their data request primitives.

8.2.2.3 The layer 2 protocol is covered by the HDLC standards. The application conditions are given as delta specifications.

8.2.2.4 The frame structure according to [ISO/IEC 3309] and the elements of the control procedures according to [ISO/IEC 4335] shall be used.

8.2.2.5 The HDLC balanced asynchronous class (BAC) of procedures shall be used. The HDLC basic procedure shall provide the following error detection and recovery features:

- automatic re-transmission after missing acknowledge;
- 16 bit frame check sequence.

8.2.2.6 Some standardised options of HDLC are required as defined in [ISO/IEC 7809]:

- option 3.2: multi-selective reject (SREJ);
- option 4: unnumbered information (UI)⁶;
- option 10: extended sequence numbering (SABME);
- option 15.1 Start/stop transmission.

Note: Option 8 is not used (see 8.2.2.9).

Note: Option 2 is not used.

8.2.2.7 The elements supporting the procedure and options are described in [ISO/IEC 7776] except for the following rules⁷:

- a) Only the single link procedure is used.
- b) An independent HDLC protocol is used in each B/B_m channel.
- c) In the case of concurrent transmission requests for the data link (one I frame and one UI frame), the UI frame has to be transmitted with higher priority.
- d) An "unsolicited DM" is not used.
- e) In the case of FRMR condition link reset shall not be used. The receiver of FRMR shall send a DISC frame as a response (see [ISO/IEC 7776] section 5.6).
- f) An "unsolicited UA response frame" in the information transfer phase is ignored.
- g) "Basic mode of operation" is not used.
- h) Extended sequence numbering (modulo 128) is used.
- i) The calling system plays the DTE role and the called system plays the DCE role. These roles include the layer 2 addressing. The system initiating the establishment of the B/B_m channel is considered to be the calling system.
- j) The end system with the DTE role is responsible for the establishment and release of the layer 2 connection. Only the end system with the DTE role is allowed to send SABME frames. However, the other system can also release the connection.
- k) In the case of ordered release of the connection, the layer 2 connection should be released before the B/B_m channel.
- l) The interframe time fill-in shall be "Mark".
- m) The layer 2 protocol shall not insert any inter-octet time fill-in (ISO 4335 §4.1.4.2).
- n) Only control escape transparency shall be used (ISO/IEC 7776 §3.5.2.2).

8.2.2.8 The order of transmitting bits within each octet in the information field is to send the least significant bit first.

⁶ Applied for HP data. In the case of error, there is no layer 2 re-transmission .

⁷ For further detailed information see Annex D.

8.2.2.9 Response I frames shall be sent only with F=1. Response I frames with F=0 shall not be sent.

8.2.2.10 SREJ shall be sent as response frame only.

8.2.2.11 UI frames can be sent either as command or as response; the receiver shall not check it. The receiver shall not check the P/F bit, which can be set to 1 or 0.

8.2.3 Network Layer

8.2.3.1 Co-ordinating Function

8.2.3.1.1 The co-ordinating function provides the synchronisation mechanism required between the usage of the B/B_m- channel protocol stack and the signalling protocol stack.

8.2.3.1.2 The following tasks shall be performed by the co-ordinating function:

- a) Registration with requested/appropriate GSM PLMN.
- b) Establishment of network connection(s) by means of the GSM 07.07 and ETS 300102 signalling protocol.
- c) Mapping of the requested QoS parameters into signalling information.
- d) Connection refusal when applicable
- e) Connection release by means of the GSM 07.07 and ETS 300102 signalling protocols
- f) Handling of the GSM/ISDN supplementary services information.
- g) Error reporting and retrieving information on error reasons received from GSM 07.07 and ETS 300102 signalling protocols.
- h) disconnect of data link layer followed by release of physical connection in case of disconnect phase (e.g. when the number of retransmission attempts exceeds N2 or in case of FRMR condition detected) (see ISO/IEC 7776 section 5.3.3, 5.3.4).

8.2.3.1.3 If a B/B_m-channel connection is not already established, the receipt of an N-CONNECT.request primitive shall cause the control plane signalling procedures for circuit switched connection to establish a B/B_mchannel connection. The requested QOS parameters for the N-connection shall be mapped onto user-network signalling information elements.

8.2.3.1.4 During B/B_m- channel connection establishment, supplementary services information and signalling protocol cause codes shall be handled as specified in [GSM/R interfaces].

8.2.3.1.5 NOTE: A simplified handling of signalling information and error reasons is allowed for Class 1.

- 8.2.3.1.6 When the B/B_m- channel connection is established in layer 1, the co-ordinating function informs the B/B_m- channel network layer entity and B/B_m- channel data link layer entity. The data link layer entity performs synchronisation with its peer data link layer entity and informs the network layer entity after successful synchronisation.
- 8.2.3.1.7 Each RCS has to operate one or more B/B_m-channels with peer RCS. The layer 3 and layer 2 entities are processed independently in each B/B_m- channel.
- 8.2.3.1.8 When the N-DISCONNECT.request is received, the B/B_m- channel is released by the GSM 07.07 and ETS 300102 signalling protocols.
- 8.2.3.2 B/B_mChannel network Layer
 - 8.2.3.2.1 According to the OSI reference model the network layer of a B/B_m- channel provides functional and procedural means to establish, maintain, and release network connections between open systems containing communicating transport entities independent from routing and relay considerations.
 - 8.2.3.2.2 For Layer 3, the T.70 network layer protocol for CSPDNs shall be used in the B/B_m- channel. Only the T.70 header (refer to T.70 Section 3.3.3 and Figure 14) is applied: Segmentation/re-assembly of the NSDU out of/into sequences of NPDUs and setting of the M-Bit.
 - 8.2.3.2.3 NOTE: ISDN B-channel circuit switched mode: T.90 specifies in appendix II the T.70 network layer protocol as an optional protocol usable on a per call basis.

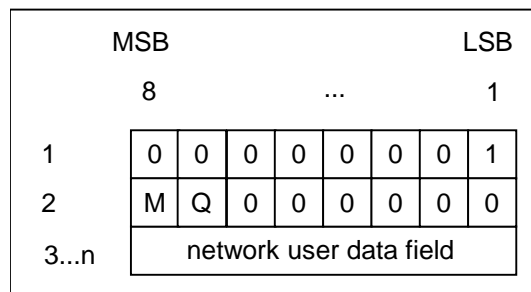

Figure 14 Format of NPDU

- 8.2.3.2.4 When the more data mark (M) is set to 1 it indicates that more data is to follow. The Q-bit is reserved; currently the value is set to 0.
- 8.2.3.2.5 Error handling of T.70 header is a matter of implementation.

8.2.4 Transport Layer

8.2.4.1 Functions

8.2.4.1.1 The transport layer only establishes a transport connection if a network connection exists. If the network connection does not exist at the moment when an association is requested, the transport entity first of all requests the establishment of such a connection and then automatically sets up the transport connection. Each different application type should have established its own transport connection for the intended duration of the communication. TP2 shall be used in order to provide more than one transport connection over the same network connection.

8.2.4.1.2 The layer 4 protocol is covered by ITU-T Rec. X.224 "Protocol for providing the OSI connection-mode transport service"; the application conditions are given as delta specifications in section 8.2.4.7. The elements of transport procedure class 2 (TP2) listed in Table 36 shall be used. Some special problems of the protocol are described in the following sections.

Table 36 Procedure elements of TP2

Protocol mechanism	X.224 Cross-ref.	Variant or Option	TP Class 2	used	not used
Assignment to network connection	6.1.1		x	*	
TPDU transfer	6.2		x	*	
Segmenting and reassembling	6.3		x	*	
Concatenation and separation	6.4		x		*
Connection establishment	6.5		x	*	
Connection refusal	6.6		x	*	
Normal release	6.7	Explicit	x	*	
Error release	6.8		x	*	
Association of TPDU's with transport connection	6.9		x	*	
TPDU numbering	6.10	Normal Extended	m (Note 1) o (Note 1)	*	*
Expedited data transfer	6.11	Network Expedited	x (Note 1)		*
Reassignment after failure	6.12		na		*
Retention and acknowledgement of TPDU's	6.13	Confirmation of receipt	na		*
Re synchronisation	6.14		na		*
Multiplexing and de-multiplexing	6.15		x (Note 2)	(Note 3)	*
Explicit flow control	6.16		m	*	
Checksum	6.17		x		*
Frozen references	6.18				*
Re transmission on time-out	6.19		na		*
Resequencing	6.20		na		*
Inactivity control	6.21		na		*
Treatment of protocol errors	6.22		x	*	
Splitting and recombining	6.23				*

Protocol mechanism	X.224 Cross-ref.	Variant or Option	TP Class 2	used	not used
NOTES					
<p>X Procedure always included in class 2</p> <p>na Not applicable in TP class 2</p> <p>m Negotiable procedure whose implementation in equipment is mandatory</p> <p>o Negotiable procedure whose implementation in equipment is optional</p> <p>1 Not applicable in class 2 when non-use of explicit flow control is selected.</p> <p>2 Multiplexing may lead to degradation of the quality of service if the non-use of explicit flow control has been selected.</p> <p>3 Option. This option is not required for ETCS level1 radio in-fill unit.</p>					

8.2.4.2 Priority handling

8.2.4.2.1 The priority has to be handled:

- during set-up phase of the physical connection ("eMLPP priority"): The GSM phase 2+ supplementary service "Enhanced Multi-Level Precedence and Pre-emption service (eMLPP)" [GSM 02.67] will provide different levels of priority for call set-up and for call continuity. The GSM PLMN operator allocates set-up classes and pre-emption capabilities to each priority level according to the railway specifications (refer to EIRENE SRS). The priority is requested during set-up of the physical connection by the co-ordination function. The priority level 1 (Control-command safety) will be used for all application types.
- by the scheduling algorithm during multiplexing ("transport priority"): A transport priority is defined for the different application types (see section 8.3.2.2)

8.2.4.2.2 NOTE: All priority treatment of the transport layer refers to transport priorities.

8.2.4.2.3 The action taken by the transport protocol during connection lifetime is not explicitly defined in X.224.

8.2.4.2.4 The following policy has to be adopted in each CFM at transport connection set-up request:

- If sufficient resources are available to provide the service (in both the local and distant system) the new connection will be established.
- Otherwise the connection request is refused.

8.2.4.2.5 The handling of transport priority during the data phase of the transport connection is specified in the following section.

8.2.4.3 Multiplexing

8.2.4.3.1 Multiplexing of two or more transport connections onto a single network connection can be provided as an option. This option is not required for ETCS level 1 radio in-fill unit.

8.2.4.3.2 Multiplexing requires the following functions:

- a) The identification of the transport connection source is provided by an appropriate DST-REF parameter of each DT TPDU and additionally the SRC-REF parameter of CR, CC, DR, and DC TPDU. These parameters are used to identify each TPDU in a given transport connection and ensures that data from different transport connections are not mixed or mis-routed.
 - b) Peer flow control regulates the rate at which TPDU of individual transport connections are sent to the peer transport entity. The use of explicit flow control on each transport connection will conform to X.224 recommendation sub-section 10.2.4.2 and will be used in addition to any other form of flow control performed in the lower layers.
 - c) The scheduling of the next transport connection to be served over the network connection: The connection associated with application type ATP has to be served first.
 - d) The transport connection endpoint identifier (TCEPID) at the TSAP provides local identification of the transport connection. Service boundary flow control is provided as a matter of implementation. These local flow control mechanisms shall be in accordance to transport priority requests.
- 8.2.4.4 Release of the network connection
- 8.2.4.4.1 The release of network connection occurs when all the transport connections associated with it have been released.
 - 8.2.4.4.2 In the case of an abnormal release by the network, all associated transport connections are released and the transport service users are immediately informed.
- 8.2.4.5 Segmenting/reassembling
- 8.2.4.5.1 If the size of the transport service data unit (TSDU), which is requested for transmission to the transport layer, exceeds the maximum size of the user data part of the DT TPDU, then segmentation must first be performed on the TSDU. One TSDU is mapped into more than one TPDU with added protocol control information.
 - 8.2.4.5.2 The segmenting/reassembling reduces the throughput because of the increased overhead in the TPDU. Normal priority user data is segmented, if it does not fit into one TPDU. The recommended length of TSDUs is ≤ 123 octets.
 - 8.2.4.5.3 The transmitting transport entity should apply the length 128 octets for all TPDU except the last one.
 - 8.2.4.5.4 The peer transport entity has to identify the transport connection of the received segments and to reassemble the segments into the TSDU.
 - 8.2.4.5.5 The receiving transport entity shall be able to accept TPDU of different length: from 1 up to 128 octets.
 - 8.2.4.5.6 If one TPDU (which is requested for transmission to the network layer as NSDU) is handled by the network entity, the next TPDU has to wait. Segmenting of long lower

© This document is the property of

ALCATEL * ALSTOM * ANSALDO SIGNAL * BOMBARDIER * INVENSYS RAIL * SIEMENS

priority TSDU provides the possibility to multiplex TPDU of higher priority with the stream of lower priority TSDU segments.

8.2.4.6 Addressing

8.2.4.6.1 The ConnectRequest TPDU (CR TPDU) and the ConnectConfirm TPDU (CC TPDU) contain address information: the calling transport selector, and the called transport selector or the responding transport selector in the respective TSAP IDs. The transport selector consists of the sub-parameters application type, ETCS ID type and ETCS ID (Figure 15 and Table 37).

8.2.4.6.2 NOTE: The parameter code and length shown in Figure 15 indicate the structure according to X.224 section 13.3.4

Parameter code (1 octet)	Parameter length (1 octet)	Application type (1 octet)	ETCS ID type (1 octet)	ETCS ID (3 octets)
-----------------------------	-------------------------------	-------------------------------	---------------------------	-----------------------

Figure 15 Structure of the transport selector

8.2.4.6.3 The first octet of the transport selector is used for the assignment of the application type (Table 37). The first 5 bits specify the main application type. The minor application types specify the main application types in more details. Every main application type can comprise eight applications. The general structure of the parameter "application type" is:

$$\begin{aligned} &\text{application type (1 octet) = main application type (5 bits)} \\ &\quad + \text{ minor application type(3 bits)} \end{aligned}$$

8.2.4.6.4 The application type of calling and called transport selectors has to be identical. If the called CFM does not support a requested application type, the establishment request will be rejected by DR TPDU.

Table 37 Format and encoding of transport selector

Octet	Bit 8765 4321	Content
1	1100 0001 1100 0010	Parameter code of calling TSAP or Parameter code of called TSAP
2	0000 0101	Parameter length (fixed length=5)
3	xxxx xxxx	Application type ¹
	0001 0xxx 0001 0000 0001 0001 0001 0111	ATP ERTMS/ETCS level 2/3 ERTMS/ETCS level 1 National use ²
	0001 1xxx 0001 1010 0001 1011	National use for trackside equipment RBC-Interlocking communication RBC-RBC communication

Octet	Bit	Content
	8765 4321	
	0001 1100	Interlocking-Interlocking communication
	0010 0xxx 0010 0000 0010 0001	Key management KMC/KMC communication KM domain internal communication
	1111 1111	Reserved for error handling
4	0000 0000 0000 0001 0000 0010 0000 0011 0000 0100 0000 0101 0000 0110 1111 1111	ETCS ID type Radio in-fill unit RBC Engine Reserved for Balise Reserved for Field element (Level crossing,...) Not required for Class 1 Key management entity Interlocking related entity Unknown ³
5-7		ETCS ID
NOTE:		
<ol style="list-style-type: none"> 1. Application type ATP is mandatory. All other application type values are reserved. 2. Minor application type "National use" is reserved for non-interoperable national applications. 3. Can only be used together with an ETCS ID value "unknown". 		

8.2.5 Applicability conditions of X.224

Table 38 Applicability conditions of X.224

Section	Application conditions
Introduction	These application conditions only apply for the RCS specification.
§ 1	Transport procedure class 2 (TP class 2) for the connection-oriented data transfer shall be used. All other TP classes of X.224 shall not shall not be used. "Conformance testing" shall not be used.
§ 4.2	ED, EA, and RJ TPDU shall not be used.
§ 5.1	The communication services are specified in section 8.1. Tab.1/X.224 shall not be used.
§ 5.2	The network service used is a "connection oriented network service(CONS)". The parameter exchange between the transport entity and the network service provider is implementation dependent. The network service primitives according to X.213 should be used. The following applies for Tab.2a/X.224, if used: <ul style="list-style-type: none"> • N-DATA-ACKNOWLEDGE primitives shall not be used. • N-EXPEDITED-DATA primitives shall not be used. With N-CONNECT primitives, "receipt confirmation option", "expedited data option" and "NS user data" shall not be used. • With N-DISCONNECT primitives, "NS user data" shall not be used. • N-UNITDATA shall not be used. • Tab. 2b/X.224 shall not be used.
§ 5.3.1	The future functions "encryption", "accounting mechanisms", "status exchange", "blocking", "temporary release of network connections", and "alternative checksum algorithm" shall not be used. "Monitoring of QoS" shall not be used.

Section	Application conditions
§ 5.3.1.1	c) "error detection" shall not be used. d) "error recovery" shall not be used.
§ 5.3.1.2	b) All transport connections from trainborne transport layer entity to the same trackside layer entity and vice versa are multiplexed onto one network connection. ⁸ (Option) c) The default size of the TPDU shall be 128 octets. e) The called network address, if provided, shall be used as network address. If this network address is not provided by T-CONNECT.request, the ETCS IDs have to be mapped ⁹ . f) A TCEPID should be used to distinguish between transport connections. g) "TS user data" can be used. h) "inactivity timers" shall not be used.
§ 5.3.1.3	a) "concatenation and separation" shall not be used. c) "splitting and recombining" shall not be used. f) "expedited data" shall not be used.
§ 5.4.1	TP class 2 shall be used.
§ 5.4.2	The TP class cannot be negotiated. The accepted class and its options must be equal to the required class 2.
§ 5.4.3	A network connection of Type A is a precondition.
§ 5.4.4	TP class 0 shall not be used.
§ 5.4.5	TP class 1 shall not be used.
§ 5.4.6.2	"Explicit flow control" shall be used.
§ 5.4.7	TP class 3 shall not be used.
§ 5.4.8	TP class 4 shall not be used.
§ 5.5	TP class 4 with "connectionless-mode network service (CNLS)" shall not be used.
§ 6.1.1.3	All transport connections between the same pair of transport layer entities are multiplexed onto one network connection. ¹⁰ (Option) Procedures for "re-synchronisation", "reassignment after failure" and "splitting" shall not be used. Note 3: The value of the appropriate delay should be 0s. ¹¹ Note 4: shall not be used. Note 5: shall not be used.
§ 6.1.2	"connectionless-mode network service" shall not be used.
§ 6.2.2	N-EXPEDITED-DATA and N-UNITDATA primitives shall not be used.
§ 6.2.3	"connectionless-mode network service" shall not be used. The network expedited variant shall not be used.
§ 6.4	"concatenation and separation" shall not be used.
§ 6.5.2	N-UNITDATA primitives shall not be used.

⁸Refer to section 8.2.4.3

⁹Refer to section 8.3.1

¹⁰Refer to section 8.2.4.3

¹¹Refer to section 8.2.4.4

Section	Application conditions
§ 6.5.3	<p>The following TPDU parameters shall not be used:</p> <ul style="list-style-type: none">• use of extended format;• version number;• protection;• checksum;• additional option selection;• alternate protocol classes;• acknowledge time;• inactivity time;• residual error rate;• reassignment time;• Option “non-use of explicit flow control in class 2”. <p>The following TPDU parameters should not be used:</p> <ul style="list-style-type: none">• TPDU size (proposed and selected);• preferred maximum TPDU size (proposed and selected). <p>If these parameters are used, the receiver shall ignore them.</p>

Section	Application conditions
§ 6.5.4	<p>Transport connections are only established by the initiator of the network connection.</p> <p>Optionally, the responder can try to establish a transport connection. If it cannot be negotiated with peer transport layer entity or peer TS user, the transport connection establishment request will be rejected.</p> <p>"splitting and recombining" shall not be used.</p> <p>The timer TS1 is a matter of local implementation.</p> <p>The network expedited variant shall not be used.</p> <p>a) A TCEPID should be used as a reference.</p> <p>c) "initial credit" equals to 15 for transport connections with application type ATP; "initial credit" equals to 1 for all other transport connections (if option "Multiplexing" is used).</p> <p>e) "acknowledge time" shall not be used.</p> <p>f) "checksum" shall not be used.</p> <p>g) "protection" shall not be used.</p> <p>h) "inactivity time" shall not be used.</p> <p>o) Option "non-use of explicit flow control in class 2" shall not be used</p> <p>The following parameters shall not be negotiated:</p> <p>i) "Protocol class" shall be always 2; "alternative class" shall not be used.</p> <p>Table 3/X.224 shall not be used. The following parameters shall not be negotiated:</p> <p>j) The default size of the TPDU shall be 128 octets. This shall be maximum size usable.</p> <p>k) "Preferred maximum TPDU size" should not be used.</p> <p>l) "extended format" shall not be used.</p> <p>m) "checksum" shall not be used.</p> <p>n) The parameter value of "priority" shall be set according to the value of transport priority¹².</p> <p>p) "network receipt confirmation" and "network expedited data transfer" shall not be used.</p> <p>q) "transport expedited data transfer" shall not be used.</p> <p>r) "use of selective acknowledgement" shall not be used.</p> <p>s) "use of request acknowledgement" shall not be used.</p> <p>t) "version number" shall not be used.</p> <p>u) "reassignment time parameter" shall not be used.</p>
§ 6.5.5	"connectionless-mode network service" shall not be used.
§ 6.6	The required class and options must be accepted.
§ 6.7.1	The explicit "release procedure" shall be used. ¹³
§ 6.7.1.4	The implicit "release procedure" shall not be used. If the network connection is interrupted, an error indication should be given to the application.
§ 6.7.1.5	<p>The orderly release of the transport connection requires the availability of the network connection.</p> <p>The release may result in discarding of TPDU.</p> <p>Note 5: a network connection shall be immediately released in order when all transport connections multiplexed onto the network connection have been released.</p> <p>Note 6: The timer TS2 is a matter of local implementation.</p>
§6.7.2	"connectionless-mode network service" shall not be used.

¹²Refer to section 8.3.2.3.4

¹³Refer to 8.2.4.4

Section	Application conditions
§ 6.8	"Error release" shall be used. On receipt of N-RESET.indication a N-DISCONNECT.request has to be issued.
§ 6.9.1.2	N-EXPEDITED-DATA primitives shall not be used.
§ 6.9.1.4.2	f) Add: The DST-REF parameter shall be mapped onto the local "transport connection endpoint identifier (TCEPID)".
§ 6.9.2	"connectionless-mode network service" shall not be used.
§ 6.11	"expedited data transfer" shall not be used.
§ 6.12	"reassignment after failure" shall not be used.
§ 6.13	"retention and acknowledgement of TPDU's" shall not be used.
§ 6.14	"re-synchronisation" shall not be used.
§ 6.15	Details of multiplexing are specified in section 8.2.4.3
§ 6.15.2	ED, EA, and RJ TPDU's shall not be used.
§ 6.15.3	Note 2: "concatenation" shall not be used.
§ 6.16	Explicit flow control shall be used.
§ 6.17	"checksum" shall not be used.
§ 6.18	"frozen reference" shall not be used.
§ 6.19	"re transmission on time-out" shall not be used.
§ 6.20	"resequencing" shall not be used.
§ 6.21	"inactivity control" shall not be used.
§ 6.22.2	"connectionless-mode network service" shall not be used.
§ 6.23	"splitting and combining" shall not be used.
§ 7	Tab.6/X.224 shall not be used. Refer to Table 36.
§ 8	TP class 0 shall not be used.
§ 9	TP class 1 shall not be used.
§ 10.2.1	d) "concatenation and separation" shall not be used. f) "multiplexing and de-multiplexing" are used.
§ 10.2.3	Data transfer without flow control shall not be used.
§ 10.2.4.1	"segmenting and reassembling" are used.
§ 10.2.4.3	"Expedited data transfer" shall not be used.
§ 11	TP class 3 shall not be used.
§ 12	TP class 4 shall not be used.
§ 13.1	Table 8/X.224: ED, EA and RJ TPDU's shall not be used.

Section	Application conditions
§ 13.3.3	b) "initial credit" equals 15 for transport connections with application type ATP "initial credit" equals to 1 for all other transport connections (if option "Multiplexing" is used).. e) TP class 2; Options: "use of normal format in all classes" "use of explicit flow control in class 2"
§ 13.3.4	The following parameters shall be used in the variable part: a) TSAP-IDs are used. The parameter length shall be equal to 5. The parameter value contains the respective transport selector ¹⁴ . l) "Priority" shall be used. The parameter value shall be set according to the value of transport priority ¹⁵
§ 13.5.4	The variable part of the DR TPDUs should not be used.
§ 13.7.1	"extended format" shall not be used.
§ 13.7.4	The variable part shall not be used.
§ 13.8	ED TPDUs shall not be used.
§ 13.9.1	"extended format" shall not be used.
§ 13.9.4	The variable part shall not be used.
§ 13.10	EA TPDUs shall not be used.
§ 13.11	RJ TPDUs shall not be used.
§ 14	"Conformance" with ITU-T Rec. X.224 shall not be required
Annex A	TP class 0, 1, 3 and 4 and "connectionless mode network service" shall not be used
Annex B	The "network connection management sub protocol(NCMS)" shall not be used.
Annex C	"Conformance" with ITU-T Rec. X.224 shall not be required
Annex D	"checksum" shall not be used.
Annex E	shall not be used.

8.2.6 Time sequences

8.2.6.1 The time sequences are shown in the appropriate OSI layer service definition standards (e.g. for layer 4 refer to X.214). This chapter illustrates the interaction of the layers.

8.2.6.2 Figure 16 contains the connection establishment by trainborne RCS only. The signalling connection between RCS and the mobile station is established after "power-on" of the mobile station to provide the radio resources and mobile management.

¹⁴ Refer to section 8.2.4.6

¹⁵ Refer to section 8.3.2.2

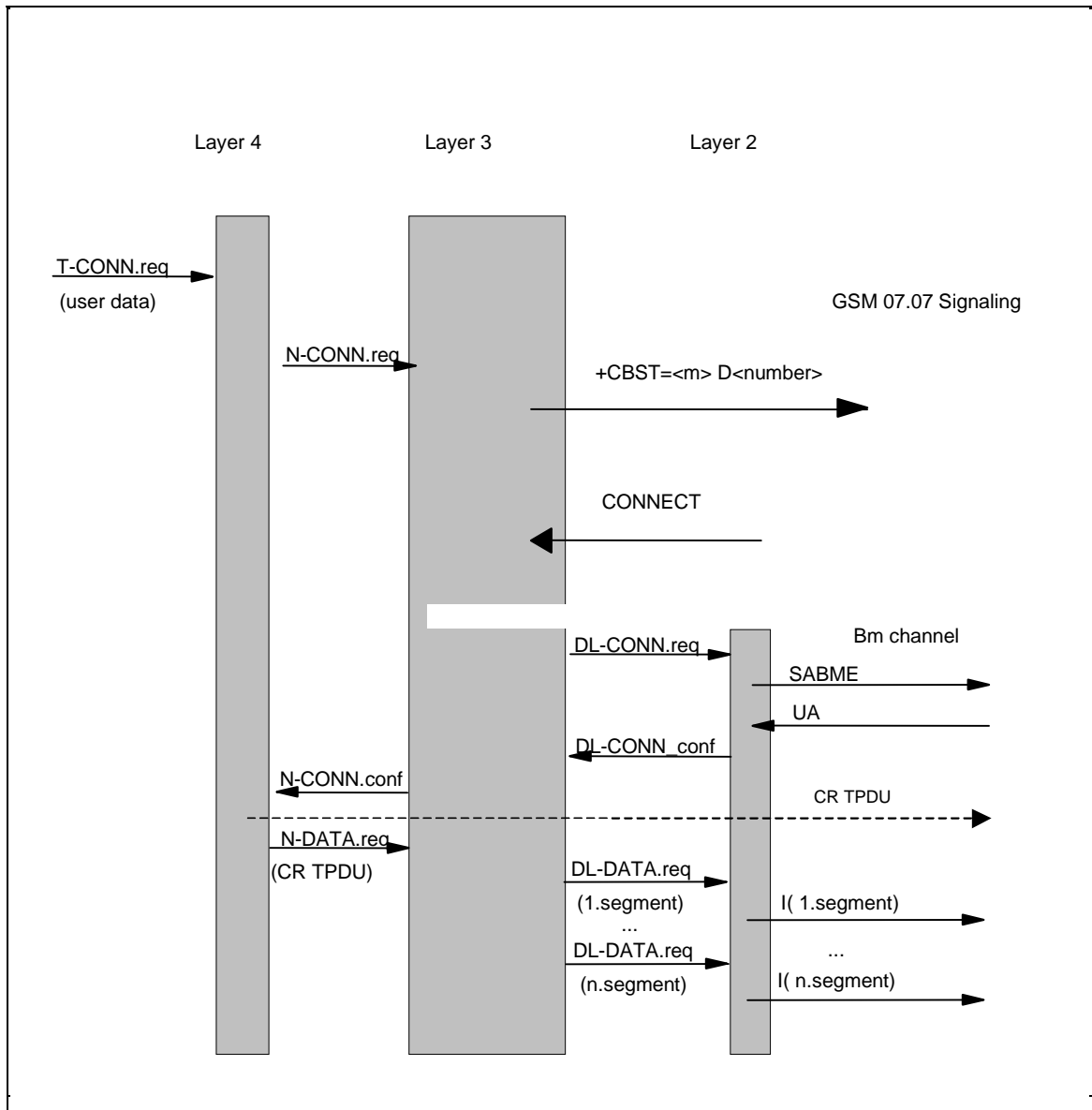

Figure 16 Detailed protocol sequence during connection establishment (requesting side only)

8.2.6.3 NOTE: The lower part of Figure 16 shows the segmentation of the CR TPDU as an example of a TPDU size > 123 octets.

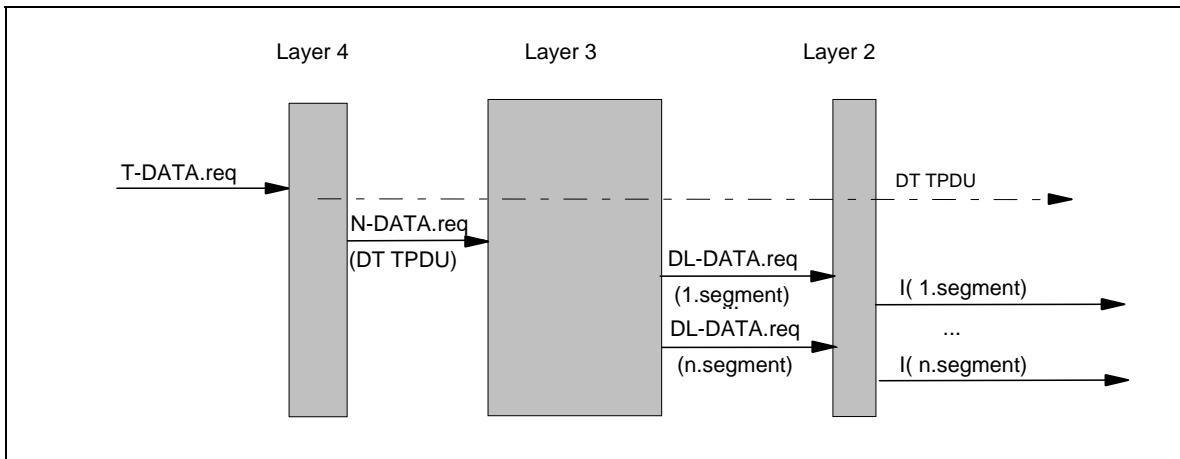

Figure 17 Detailed protocol sequence during data transfer (requesting side only)

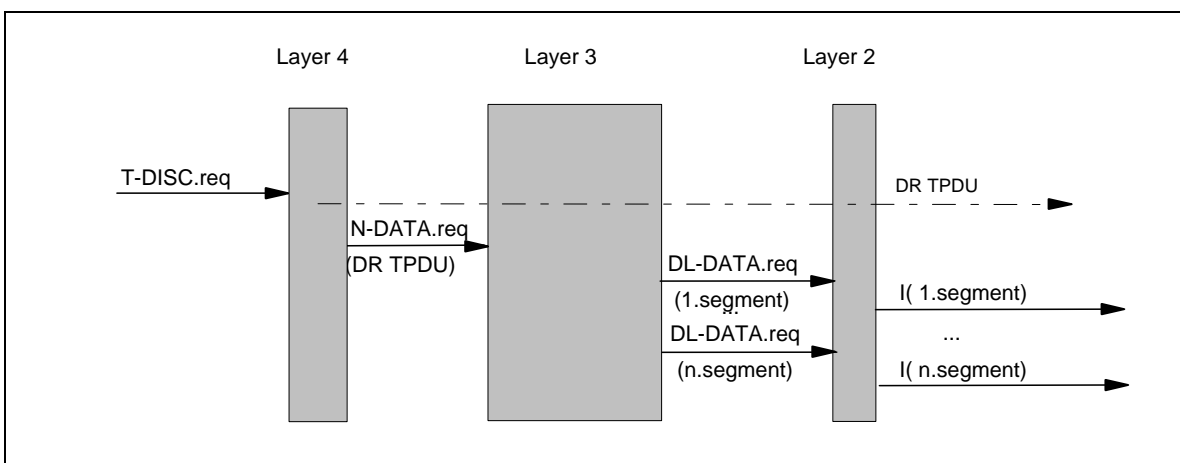

Figure 18 Detailed protocol sequence during connection release (requesting side only)

8.2.7 Relationships of PDUs and SDUs

- 8.2.7.1 This chapter contains examples of layer overheads based on a 25 octet data field in HDLC frames.
- 8.2.7.2 The safety layer, if applied, adds a header and the MAC to the user data.
- 8.2.7.3 Transport connections are multiplexed on one network connection according to their transport priority. The layer 4 adds a header to the user data.
- 8.2.7.4 If the TS user provides a normal priority TSDU of appropriate length (≤ 123 octets), the layer 4 does not segment/reassemble the user data (Figure 19). Segmenting and reassembling in layer 3 results in a 2 byte segment header.
- 8.2.7.5 In the case of a non-safe connection Figure 19 is still valid, but without the second line (SaPDU).

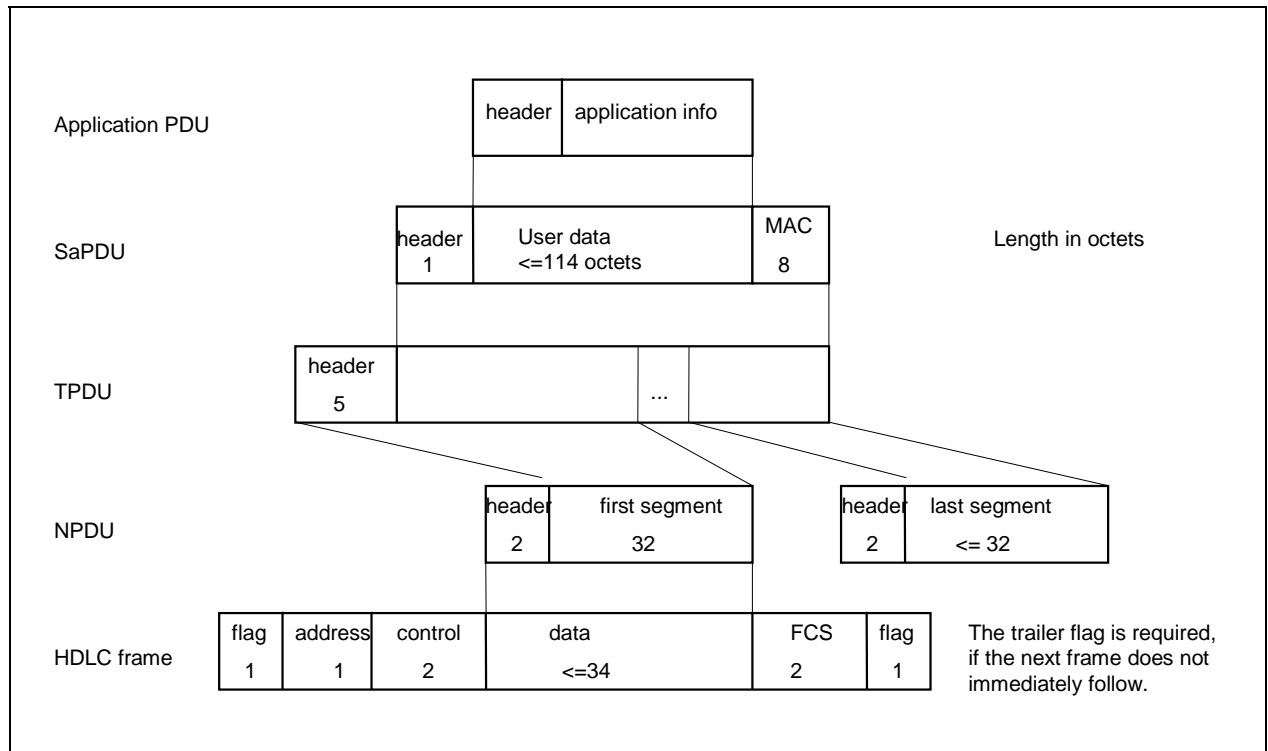

Figure 19 Example of segmenting/reassembling in layer 3

8.2.7.6 If the TS user did not provide a normal priority TSDU of appropriate length, the layer 4 segments/reassembles the user data into/from TPDU's of standard length of 128 octets. Segmenting and reassembling in layer 4 will result in a 5 byte header added to each segment (Figure 20). The layer 3 header is additionally required to be consistent with the NPDU format of the other connections.

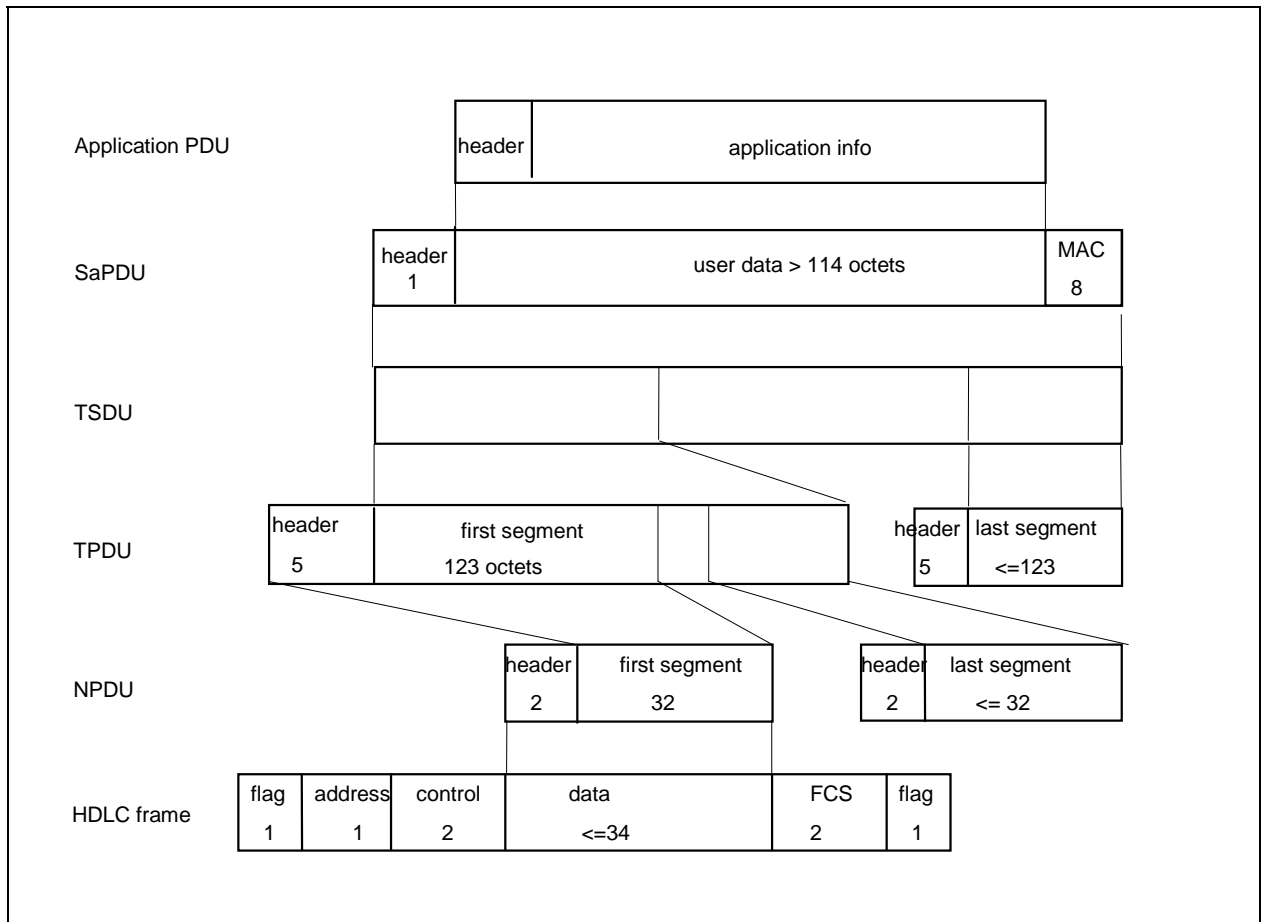

Figure 20 Example of segmenting/reassembling in layer 4 and layer 3

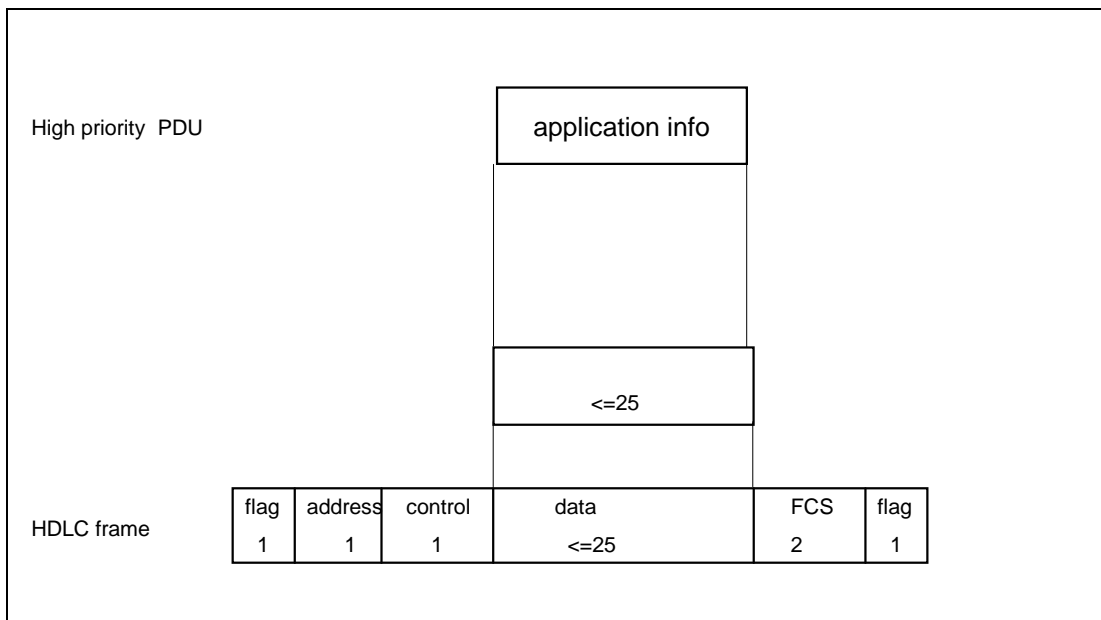

Figure 21 Example of layer overhead of high priority data

8.3 Management of Communication Functional Module

8.3.1 Call and ID-Management

- 8.3.1.1 The CFM has to establish the connections on demand between peer applications (i.e. CFM users). The details of the following tasks are a matter of implementation.
- 8.3.1.2 The RCS communication functional module optionally offers several logical connections between the trackside and the onboard equipment via the same physical channel. This option is not required for ETCS level 1 radio in-fill unit.
- 8.3.1.3 The "transport address" is a generic name that is used to identify a set of transport service access points (TSAPs) which are all located at the interface between a higher layer and the transport layer of the CFM. If a generic name is used to denote an object, then exactly one member of the set of objects will be selected.
- 8.3.1.4 The transport address is used to access a single transport service (TS) user entity. The network address by itself is not sufficient to identify a particular CFM user entity. It is necessary to refer to the requested CFM user entity type by using a special identifier or address qualifier: the application type.

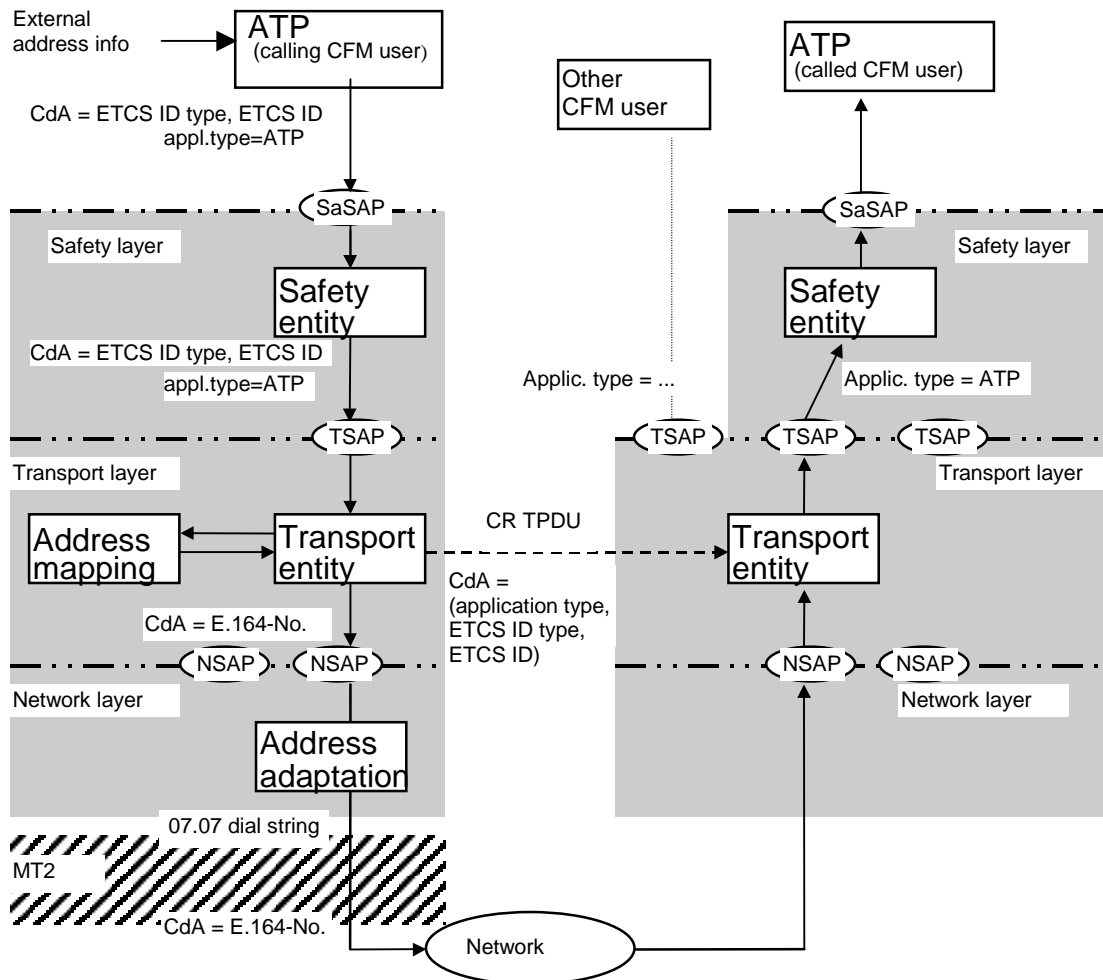

Figure 22 Example of address mapping

- 8.3.1.5 Transport layer entities and CFM user entities are bound together at TSAPs. Every CFM user entity may be bound to one or more TSAPs. This is a matter of implementation. There is no relationship between TSAPs and multiplexing. The multiplexed transport connections may terminate at different TSAPs.
- 8.3.1.6 The addresses are used in the T-CONNECT primitives (transport address) and N-CONNECT-primitives (network address) at the service interface. If a CFM user entity (e.g. the safety layer entity) wants to establish a connection with another CFM user entity, it provides information to address the called CFM user (e.g. an ETCS ID type and ETCS ID) and the application type. This address information has to be mapped into the format and structure requested by the CFM for connection establishment.
- 8.3.1.7 Figure 22 gives an example of address information mappings during the connection establishment from trainborne CFM to trackside CFM. The calling TS user entity (i.e. in this example the safety layer entity) obtains the called transport address from the application (ETCS ID type and ETCS ID). The address information will be passed through the SFM towards the CFM.
- 8.3.1.8 The calling CFM has the following tasks:
- To check, that a mobile station is registered with the mobile network contained in the T-CONNECT.request.
 - To associate the requested connection with an appropriate mobile station.
 - To derive the called network address from address information indicating the called CFM user.
 - To insert into the connection request (CR) TPDU the called transport selector (in the case of train initiated physical connection establishment according to Figure 15) and the calling transport selector.
- 8.3.1.9 To select the local NSAP by which the network service primitives (if applicable) is issued.
- 8.3.1.10 The following rules are applied to derive the called network address in the case of train initiated physical connection establishment:
1. If the T-CONNECT.request primitive contains a network address, this address has to be used for physical connection establishment. The network address is transparent for CFM.
 2. If no network address or ETCS ID type and ETCS ID, are contained in the T-CONNECT.request primitive or in the case of mapping errors, the call has to be established towards the most appropriate RBC by means of the short dialling code (refer to [EIRENE SRS]).
- 8.3.1.11 In the case of RBC-initiated physical connection establishment, the ETCS ID of the on-board equipment provided by T-CONNECT.request has to be mapped to the called network address (i.e. to the MSISDN applied).

8.3.1.12 NOTE: The details of local call and ID management (e.g. address mapping) are out of scope for this FIS. Refer to [Euroradio FFFIS] and [Subset-040] for requirements at the interface to mobile station.

8.3.1.13 Table 39 shows the defined combinations of address information values.

Table 39 Address information (train initiated call set-up)

ETCS ID type	ETCS ID	Network address	Action	Remarks
RBC	RBC ID	RBC network address provided	Use network address	
RBC	RBC ID	Network address not provided or Default value "NA unknown"	Use short dialling code "Most appropriate RBC"	Short dialling code 15xx [EIRENE SRS]
"unknown"	Default value "RBC unknown"	Network address not provided or Default value "NA unknown"	Use short dialling code "Routing to the most appropriate RBC"	Default for addressing

8.3.1.14 The ConnectRequest TPDU (CR TPDU) and the ConnectConfirm TPDU (CC TPDU) contain the calling and the called transport selectors in the format specified for the TPDUs (see section 8.2.4.6).

8.3.1.15 The trackside called network address will be a generic address to identify a set of network service access points (NSAPs), which are bound to the "Primary rate access" (ISDN-like networks). The called network number should be a "hunting number": incoming calls to the network number will be distributed by the terminating exchange (or the PABX) among a group of interfaces. One of the idle interfaces will be selected to receive the call.

8.3.1.16 The trackside sets of TSAPs are bound to special CFM user entities (e.g. in Figure 22 the safety layer entity is bound to a special TSAP). The CFM user entity A is bound to a TSAP but actually not used (may be it is a non-safe application layer entity, which has to use another TSAP and application type).

8.3.1.17 The transport layer entity in the called CFM uses:

- the address information contained in the connection request (CR) TPDU to derive the called ETCS ID type and ETCS ID and to select one appropriate TSAP (based on the application type received);
- the responding ETCS ID type and ETCS ID contained in the T-CONNECT response primitive to build the connection confirm (CC) TPDU.

8.3.1.18 If the transport layer entity of the called side is not able to select a TSAP bound with the requested application type, the CR TPDU will be rejected.

8.3.2 Configuration management

8.3.2.1 The local O&M stack provides an initial set of configuration parameters. This set can be a default set installed during manufacturing. If more than one default set exists, one of these sets can be selected prior to the journey by a local management action based on national railway rules. All these off-line management actions are out of scope of this FIS.

8.3.2.2 Configuration parameters

Table 40 Layer 2 configuration parameters¹⁶

Parameter	Symbol	Defined range of values	Applied value(s)	Comments
Address		A, B	Calling entity: A Called entity: B	
Window size	k	1 - 127	9 - 61	The window size can be different in both directions. Recommended value = 20
Acknowledge time	T1	> 500 ms	0,8 - 2 s	$T1 > T2 + 2 * \text{transfer delay}$
Local processing delay time	T2		< 80 ms	Implementation dependent
Out of service time	T3		$T3 \gg T4$	Matter of implementation (to be used only if T4 is supported)
Inactivity time	T4		Recommended value $T4 > N2 * T1$	$T4 \gg T1$ Matter of implementation
maximum number of bits in a l frame	N1	> 0	$240 \leq N1 \leq 1024$.	Flags are not included. Receive buffers shall support $N1 = 1024$. Recommended value for transmission = 312 (This is equal to 4 frames per 1 TPDU)
Maximum number of retransmission attempts	N2	> 0	3 – 6.	Note: ISO/IEC 7776 specifies the number of transmissions = $N2 + 1$ Recommended value: 5
Error detection and correction			FCS-16	No options

8.3.2.2.1 The description of the layer 2 configuration parameters is provided by [ISO/IEC 7776] section 5.7.

8.3.2.2.2 Timer T5 shall not be used.

Table 41 Layer 3 configuration parameters

Parameter	Symbol		Applied value	Comments
Maximum number of octets in a segment	N_{L3seg}		$N_{L3seg} = (N1/8) - 5$	The layer 3 header is included.

¹⁶ All recommended values in this table should be optimised (e.g. on track characteristics, industrial / rural locations etc.)

Parameter	Symbol		Applied value	Comments
				N_{L3seg} is related to the layer 2 frame length $N1$

8.3.2.2.3 The description of the layer 3 configuration parameters is provided in T.70.

Table 42 Layer 4 configuration parameters

Parameter	Symbol	Range of values	Applied value	Comments
TP class	TP x		TP 2	No choice
Procedure elements				Refer to Table 36
Standard TPDU length	N_{TPDU}	1 - 128 octets	128 octets	
Initial credit	N_{TIC}	1 - 15	15 1	Application type = ATP All other optional application types

8.3.2.2.4 The description of the layer 4 configuration parameters is provided by X.224.

8.3.2.3 QoS parameters

8.3.2.3.1 Normally, the QoS parameters give CFM users a method of specifying their needs, and give the CFM a basis for selection of the protocol or for requesting services of lower layers. For the purposes of this FIS sets of QoS parameters values are specified.

8.3.2.3.2 Each value of service primitive parameter **QoS class** is associated with a set of QoS parameter values, which represents the requirements to the physical connection to be established. The requirements are independent from application type.

8.3.2.3.3 The default value for the QoS parameter **User data rate** is 4800 bit/s.

8.3.2.3.4 The range of QoS parameter **Transport priority** is 0-5. Table 43 contains the association with application types.

Table 43 Transport priority

Value	Associated application type	Comments
0	-	Not used
1	Application type ATP	Highest value used
All other values are reserved.		

8.3.2.3.5 QoS classes 0-9 are reserved for application type ATP of ERTMS/ETCS. The data rate and eMLPP priority (refer to section 8.2.4.2) parameters have to be used during physical connection set-up.

Table 44 Mapping of QoS classes 0- 9

QoS class	Data rate [bit/s]	eMLPP priority
0	9 600	1
1	4 800	1
2	2 400	1
All other QoS class values are reserved for future use.		

8.3.3 Supervision / Diagnostics

8.3.3.1 Error handling

8.3.3.1.1 If an error occurs in the communication functional module or if the communication functional module receives an indication of an error, the error and its reason will be indicated. The different reasons require different error handling actions. The errors can be ignored, locally logged or indicated.

8.3.3.1.2 If there is a problem with call establishment, the CFM should try by itself to recover the problem. Only if the problem cannot be solved, (i.e. the transport connection can not be established), will the CFM inform the CFM user.

Table 45 Error types of the CFM and their handling

Reason/ code	Sub-reasons		Error handling action
Network error Code =1	1 2 3	Number not assigned; invalid number format Channel unacceptable Impossibility to establish physical connection for other reason. (e.g. V.25ter response No DIALTONE)	Indication of a persistent error is created by the provider and is contained in the reason parameter of the T-DISCONNECT.indication
Network resource not available Code =2	1 2 3	No channel available Network congestion Other sub-reason. (e.g. V.25ter response NO CARRIER)	Indication of a transient error is created by the provider and is contained in the reason parameter of the T-DISCONNECT.indication
Service or option is temporarily not available Code =3	1 2	QoS not available Bearer capability not available	Indication of a transient error is created by the provider and is contained in the reason parameter of the T-DISCONNECT.indication
Reason unknown Code =5			Error indication is created by the called communication functional module and is contained in the reason parameter of the T-DISCONNECT.indication.
Called TS user not available Code =6	1 2 3	Application of requested type is not supported Called user unknown (e.g. V.25ter response NO ANSWER) Called user not available (e.g. V.25ter response BUSY)	Error indication is created by the called communication functional module and is contained in the user data of the DR TPDU. The calling CFM will report the error to the calling application with the T-DISCONNECT.indication
Internal error Code =7	1 2 3	Mandatory element ¹⁷ is missing (e.g. element of a TS primitive) Inappropriate state Other sub-reasons (e.g. V.25ter response ERROR)	Error logging Deletion of the invalid message
1	8	No mobile station has been registered	T-DISCONNECT.indication The application should re-try network registration
NOTES:			
1. All other reason/sub-reason values are reserved.			
2. Reasons and sub-reasons are a matter of implementation.			
3. Reason Code 0 is reserved for normal release requested by a CFM user.			

¹⁷ Caused by the local application

8.3.3.2 Error reporting

8.3.3.2.1 The safety functional module and/or the applications are informed about error situations that lead to a disconnection by using the T-DISCONNECT indication service primitive.

Table 46 Parameter of the T-DISCONNECT Primitive and their contents

Parameter of the T-DISCONNECT Primitive	Contents
Reason	TS user invoked / TS provider invoked In the case of TS provider disconnection: error type/sub-reason (see Table 45)
User data	User data of the DISCONNECT request of the remote TS user (internal information from the remote TS user)

8.3.3.3 Error logging

8.3.3.3.1 Error logging is a matter of the implementation.

Annex A (normative) Assumptions placed on the ATP application

This section defines the conditions and constraints, which shall be covered by the ATP application when using the services provided by SFM.

- a) Protection against occurrence of message delay, wrongly sequenced messages, message deletion and message replay shall be provided by the application, if required.
- b) The procedure for HP data acknowledgement and repetition has to be defined and provided. The length of user data is restricted to maximum 25 octets.
- c) Safe connection monitoring should be provided, if required.
- d) Service primitives have to be issued according to the sequence defined.
- e) In the case of RBC area change or entrance into RBC area, the connection establishment request has to be requested as soon as possible. Normally, safe connection establishment delay is less than the value $T_{\text{estab}} = 40\text{s}$.
- f) In the case of registration with a mobile network (roaming into another GSM-R PLMN), an additional delay has to be taken into account (refer to [Subset-093 section 6.3.7]).
- g) The maximum length of an application message to be transferred is restricted to 1023 octets.
- h) If more than one ATP application is multiplexed on the same physical connection (option), the received high priority data are transferred to all ATP applications.
- i) The transfer of application data has to be finished for both directions before a connection release is requested.
- j) In the case of network caused release of the safe connection or rejected connection establishment request, the application has to request the re-establishment of the safe connection. The on-board ATP shall initiate the safe connection re-establishment. Due to possible loss of user data a re-synchronisation of the application data can be required.
- k) If required, the application has to pad the user data to octet boundaries.
- l) The application should check if the called ETCS ID of Sa-CONNECT.indication primitive is the same as its own ETCS ID (see fig.9).
- m) The OBU application has to provide the mobile network ID for a safe connection request.

Annex B (Option) Interface to communications services

B.1.1.1.1 Communication services are accessed by means of service primitives similar to the service primitives defined in X.214 for connection mode service.

B.1.1.1.2 NOTE: It is a matter of implementation to adapt this interface to implementation needs and constraints, where there is no exchange on the air gap and where there is no impact on the behaviour of the system.

B.1.1.1.3 **Class1 requirement:** The internal interface between the modules SFM and CFM is not mandatory.

B.1.1.1.4 The interface to communication services can be provided for non-safe applications.

B.1 Service primitives for connection establishment

B.1.1.1.5 The following table gives the service primitives used for connection establishment and their corresponding parameters.

Table 47 Service primitives of the communication layer for connection set-up

Primitive Parameters	T-CONNECT request	T-CONNECT indication	T-CONNECT response	T-CONNECT confirm
TCEPID		X	X(=)	X
Called address <ul style="list-style-type: none"> • Address type • Network address • Mobile network ID • Called ETCS ID type • Called ETCS ID 	X X(D) X(U) X X	X X		
Calling address <ul style="list-style-type: none"> • Calling ETCS ID type • Calling ETCS ID 	X X	X(=) X(=)		
Responding address <ul style="list-style-type: none"> • Responding ETCS ID type • Responding ETCS ID 			X X	X(=) X(=)
Application type	X	X(=)		
QoS class	X(D)			
User data	X(U)	X(=)	X(U)	X(=)
X Mandatory parameter. (=) The value of that parameter is identical to the value of the corresponding parameter of the preceding transport primitive. X(U) Use of this parameter is a CFM user option. X(D) Use of this parameter is an user option. If not provided, a default value will be used by CFM internally				

B.1.1.1.6 The parameter **TCEPID** (Transport Connection End Point Identifier) is provided locally to distinguish between different transport connections.

- B.1.1.1.7 The **Address type** qualifies the usage of sub-parameters of called address (refer to section 8.3.1 for details).
- B.1.1.1.8 The **Mobile network ID** identifies the mobile network. mobile network ID shall consist of the Mobile Country Code and the Mobile Network Code according to [ITU-T E.212].
- B.1.1.1.9 In the case of mobile originated calls, the connection request should contain the sub-parameter Mobile network ID, to request the appropriate network associated with the called user.
- B.1.1.1.10 The **Network Address**, if provided, identifies the network address of the called CFM user. This parameter is composed of sub-fields, e.g. the length of the called number, the type of number, the numbering plan, and the number itself.
- B.1.1.1.11 The parameter **ETCS ID type** together with **ETCS ID** is unique within the scope of ETCS and refers to ETCS equipment. The ETCS IDs are used by the transport layer during connection establishment. The ETCS ID type and ETCS ID together with the application type identifies the service user. ETCS ID
- B.1.1.1.12 The **Calling ETCS ID** identifies together with the **application type** the transport connection initiator. The **Called ETCS ID** identifies together with the application type the called CFM user. The **Responding ETCS ID** identifies the accepting/responding CFM user, which was locally selected by the responding transport entity.
- B.1.1.1.13 The **QoS class** is associated with a set of quality of service parameter values. The QoS parameters will not be negotiated. The requested QoS parameter values have to be accepted by the service provider and the peer application. Otherwise the connection establishment has to be rejected.
- B.1.1.1.14 The user data length is restricted to 32 octets.
- B.1.1.1.15 The following figure shows the sequence of transport service primitives at TSAP for connection establishment:

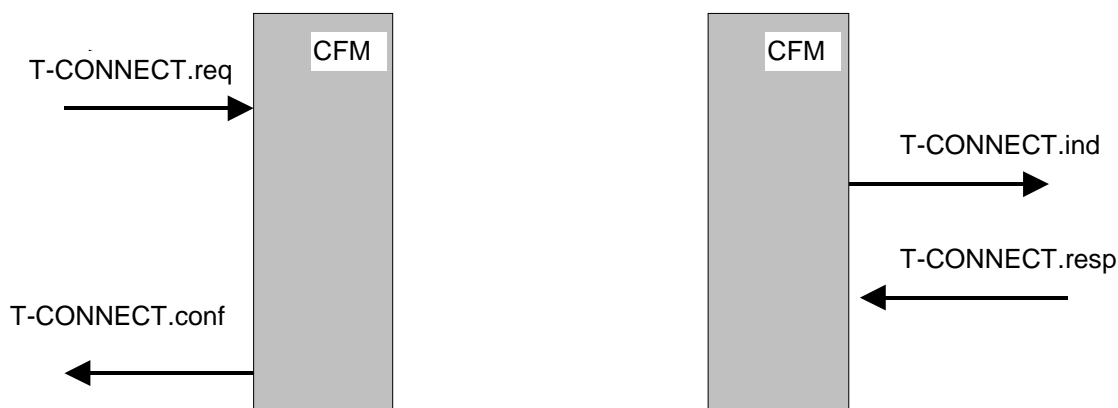

Figure 23 Sequence of primitives for connection set up

B.2 Service primitives for data transfer

- B.1.1.1.16 The following table gives the service primitives of the communication layer used for data transfer

Table 48 Service primitives of the communication layer for data transfer

Primitive Parameters	T-DATA.request	T-DATA.indication
TCEPID	X	X
User data	X	X(=)

B.1.1.1.17 A request for data transfer is made by a service user (after a successful transport connection set up) through the use of the T-DATA.request service primitive, with user data as a parameter. These data are delivered to the intended user through the use of the primitive T-DATA.indication with user data as a parameter.

B.1.1.1.18 User data are transparent to the CFM. The recommended length is ≤ 123 octets. If more than 123 octets are requested, the CFM segments/reassembles the user data.

B.3 Service primitives for HP data transfer

B.1.1.1.19 HP data transfer service primitives are supported for application type ATP only.

B.1.1.1.20 The following table gives the service primitives of the communication layer used for high priority data transfer.

Table 49 Service primitives of the communication layer for HP data transfer

Primitive Parameters	T-HP-DATA.request	T-HP-DATA.indication
TCEPID	X	X
User data	X	X(=)

B.1.1.1.21 A request for data transfer is made by a service user (after a successful transport connection set up) through the use of the T-HP-DATA.request service primitive, with user data as parameter. These data are delivered to the intended user through the use of the primitive T-HP-DATA.indication with user data as a parameter.

B.1.1.1.22 The user data length is restricted to the length of data field of the UI frame (currently less than or equal to 25 octets).

B.1.1.1.23 The following figure shows as an example the consequence of priority handling in respect to the sequence of transport service primitives for data transfer.

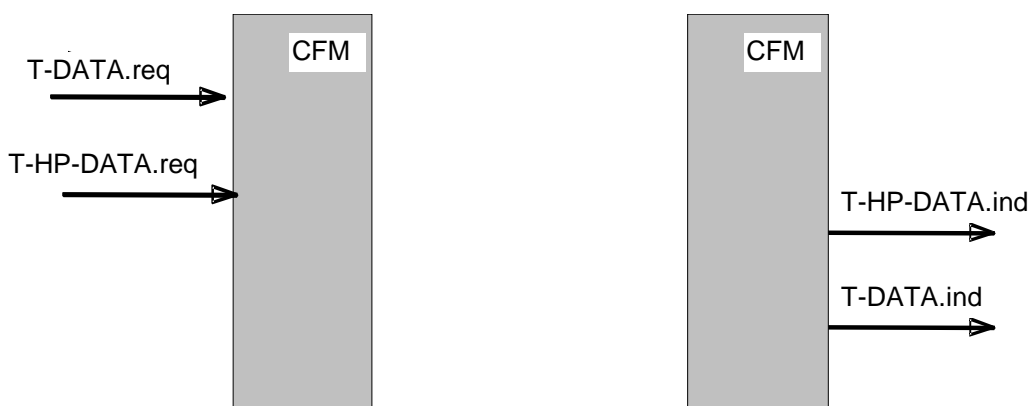

Figure 24 Sequence of primitives for data transfer (example)

B.4 Service primitives for connection release

B.1.1.1.24 The transport connection release is provided by the communication layer through the service primitive T-DISCONNECT.request. The connection release is indicated to the user using the service primitive T-DISCONNECT.indication. The connection release is indicated to the communication layer user as a consequence of a disconnection request issued by the user (normal release), as a consequence of connection establishment rejection or because of a network failure.

B.1.1.1.25 The following table gives the service primitives used for connection release.

Table 50 Service primitives of the communication layer for connection release

Primitive Parameters	T-DISCONNECT.request	T-DISCONNECT.indication
TCEPID	X	X
Reason		X(U) ¹
User data	X(U)	X(=)
Note: 1. It has to be used in the error case.		

B.1.1.1.26 Optionally, user data can be included (maximum 64 octets).

B.1.1.1.27 The following figure shows the sequence of transport service primitives at TSAP for connection release.

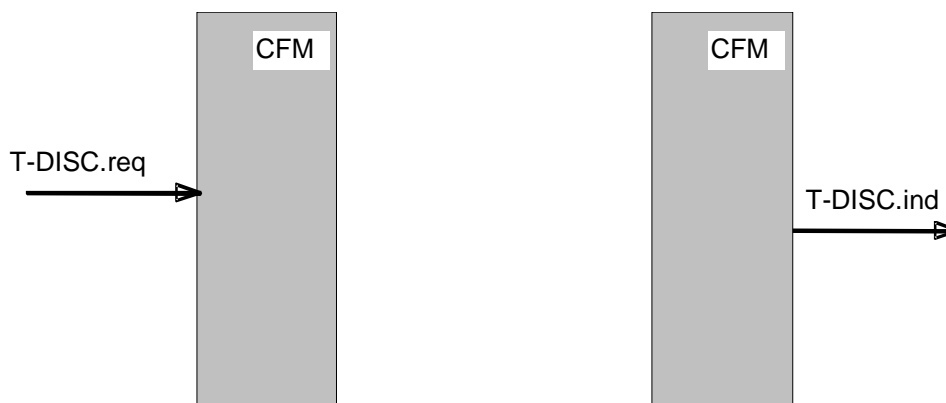

Figure 25 Sequence of primitives for connection release initiated by a CFM user

B.5 Service primitives for network registration

B.1.1.1.28 Two service primitives are provided for network registration of Mobile stations (MS) (see Table 51):

- to request mobile network registration and
- to indicate mobile network registration status

B.1.1.1.29 These service primitives apply to On Board Units only.

Table 51 Service primitives for network registration

Parameter	Primitive	T-REGISTRATION.request	T-REGISTRATION.indication
MNID list		X (>= 0 MNIDs)	(>= 0 MNIDs)

By means of the service primitive "T-REGISTRATION.request" the service user is able to request the registration of one or more mobile stations with one or more mobile networks.

B.1.1.1.30 **MNID list** is a list of mobile network IDs.

B.1.1.1.31 A **Mobile network ID** identifies the mobile network a local mobile station is requested to register with. The mobile network ID shall consist of the Mobile Country Code and the Mobile Network Code according to [ITU-T E.212].

B.1.1.1.32 The interpretation of the MNID list is matter of implementation. E.g.:

Empty :

All available mobile stations are requested to be registered using automatic network registration from GSM-R on-board radio equipment (see GSM 02.11).

One entry:

All available mobile stations are requested to be registered on network defined by the entry using manual network registration from GSM-R on-board radio equipment.

Two different entries (MNID#1, MNID#2):

The available mobile stations have to be split in two parts and to register first part on network defined by MNID #1 and second part on network defined by MNID #2.

In case not enough mobile stations are available to perform registration on both networks, registration shall be provided according to priority in the list : MNID # 1 shall be delivered first.

B.1.1.1.33 The status of registration with mobile networks is indicated by the service primitive "T-REGISTRATION.indication" to the service user. The service primitive contains a list of mobile network IDs, which are usable because mobile station(s) are registered with them.

B.1.1.1.34 NOTE: the association between MS and MNID in these service primitives is a local implementation matter.

B.1.1.1.35 The service user is not informed on how many mobile stations are available but receives only status of registered network which means implicitly that connection request on these networks can be issued or not.

B.1.1.1.36 If the indicated list of mobile network IDs is empty, the registration of mobile stations was not possible or the coverage has been lost.

B.1.1.1.37 The network registration indication can be given independently of a request. This feature allows indications after power-up or after loss of coverage. Any change on network registration can be indicated.

Annex C (Option) Safety Protocol Management

- C.1.1.1.1 The safety protocol management defines the configuration management needed to handle the parameters of the safety protocol, and the supervision and diagnostics of the safety protocol. The main emphasis is placed on achieving technical interoperability between the on-board unit and the trackside unit with respect to the safety protocol management.
- C.1.1.1.2 All details of the specification, which are implementation dependent like the generation, storage, and deletion of keys, or error logging are not covered by this specification.
- C.1.1.1.3 If the safe connection has been established, the management SaPDUs can be exchanged.
- C.1.1.1.4 The transfer of management SaPDUs is caused by internal management events. The Management SaPDUs allow the requested communication for the key management.
- C.1.1.1.5 The timer T_{trans} is applied to check the maximal acceptable delay of a management transaction. The timer T_{trans} is set after transmission of the **RQ SaPDU** (by means of a **T-DATA.request**) and is stopped after receiving the related RP SaPDU (included in the **T-DATA.indication**). In the case of time-out, the pending transaction is cancelled, and the request is sent again. The timer T_{trans} is fixed to 1minute.
- C.1.1.1.6 In case of disconnection during the management transaction, the request will be repeated: the receiver of a RQ SaPDU will not establish the physical link and directly send the RP SaPDU: it will wait until a new safe link is established and the RQ SaPDU is received again before answering. An RP SaPDU must always be linked to an RQ SaPDU of the same session.

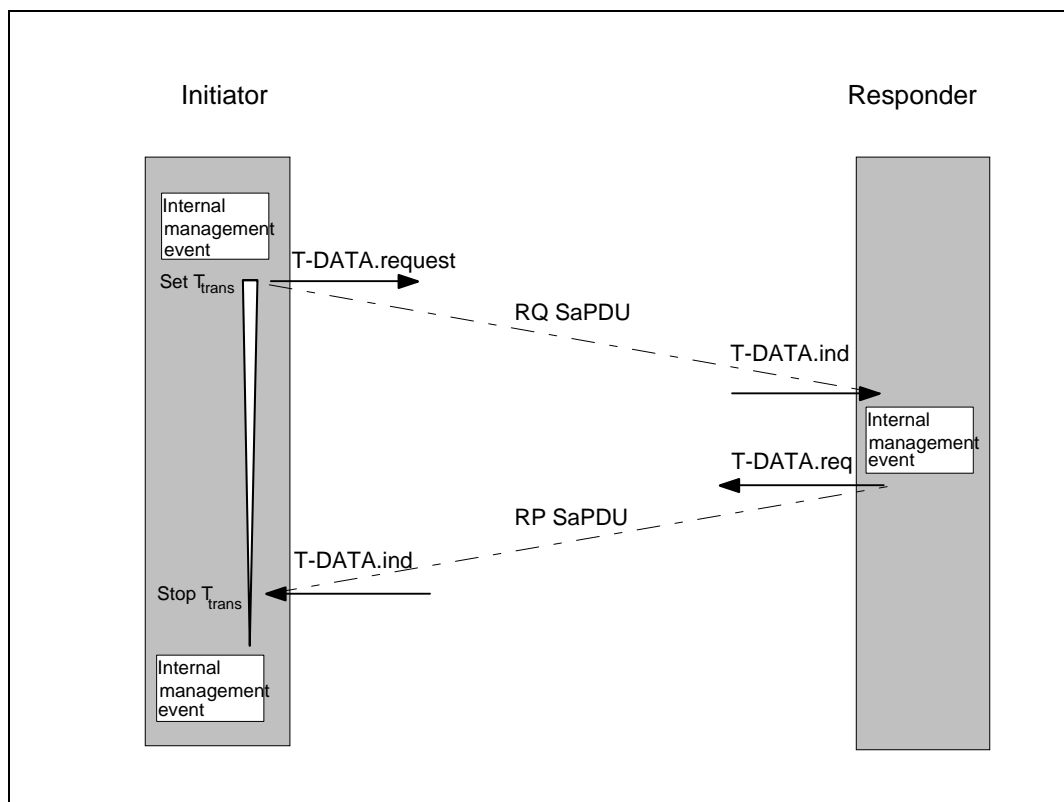

Figure C-1 Time sequence of a management transaction

C.1 Management SaPDUs

C.1.1.1.7 The Management SaPDUs are used for exchanging messages for the key management. The on-board equipment will receive the Management SaPDUs (messages for the key management), directly from its KMC.

C.1.1.1.8 For exchanging RP SaPDUs and RQ SaPDUs, it is necessary to establish first a safe connection (I&A dialogue). The structure of management SaPDUs is specified in Table 52.

Table 52 Structure of a Management SaPDU

Header	Identifier	Sub-Type of Message	Data	MAC
1 octet	1 octet	1 octet	variable	8 octets

C.1.1.1.9 The **request management SaPDU (RQ)** and **response management SaPDU (RP)** consist of the fields specified in Table 53.

Table 53 Structure of RQ and RP SaPDU

Octet	Bit 8765 4321	Field ¹⁸
1	xxx. 000. 001. 010. 101. 110.	ETCS ID type of the SaPDU sender Radio in-fill unit RBC Engine Key management entity Reserved for Interlocking related entity Not required for Class 1
1	...1 011. ...1 100.	Message Type Identifier: RQ Message Type Identifier: RP
1x	Direction flag
2	xxxx xxxx	Identifier
3	xxxx xxxx	Sub-Type of Message
4 ... 4+n-1	xxxx xxxx ... xxxx xxxx	Data (1 octet ≤ length ≤ 1021octets): MANDATA.
4+n ... 4+n+7	xxxx xxxx ... xxxx xxxx	MAC field (the MAC is computed according to the rules given in the peer entity and message origin authentication procedure).

C.1.1.1.10 The **Identifier** is arbitrarily chosen by the sender. The aim of this identifier is to make a link between a response and a request. The identifier will also be used in order to avoid a replay attack. Therefore, inside a session, the same identifier cannot be used twice.

C.1.1.1.11 This means, that, inside a session, no more than 256 exchanges can be carried out. The identifier can be "a sequence number" for example, but it is not required to do a check on the right "sequence" at the reception.

C.1.1.1.12 The sender can choose to use a one byte random number for identifying the messages; it must just guarantee that the same random number will not be used twice in the same session.

C.2 Error Handling

C.1.1.1.13 Error type: Replay of a message (same message type, with same content when another type was expected)

Table 54 Sub-reasons for the error type 'failure in sequence integrity'

Reason Code	Sub-reason Code	Description	Error handling action

¹⁸ The exact format of the messages is defined in the Unisig documents related to on-line key management.

Reason Code	Sub-reason Code	Description	Error handling action
5	5	Replay of management message exchanged between KMC and entity	Sa- REPORT.indication
5	6	Missing management message exchanged between KMC and entity	Sa- REPORT.indication

C.1.1.1.14 Error type: Time out at connection establishment or for management transaction.

Table 55 Sub-reasons for the error type 'failure in connection monitoring'

Reason Code	Sub-reason Code	Description	Error handling action
7	4	Time out of T_{trans} without receiving the correct RP SaPDU	Sa-REPORT.indication

C.1.1.1.15 Error type: Failure in the sequence of SaPDUs during connection set up and during management functions, respectively.

Table 56 Sub-reasons for the error type 'failure in sequence of the SaPDUs'

Reason Code	Sub-reason Code	Description	Error handling action
9	4	Transmission of RQ SaPDU but a message different from RP SaPDU is obtained.	Sa-REPORT.indication

C.1.1.1.16 Error type: SaPDU too short, i.e. fields are missing

Table 57 Sub-reasons for the error type ' SaPDU too short, i.e. fields are missing'

Reason Code	Sub-reason Code	Description	Error handling action
10	6	RQ SaPDU too short	Sa-REPORT.indication, rejection of RQ SaPDU
10	7	RP SaPDU too short	Sa-REPORT.indication, rejection of RP SaPDU

Annex D (Informative) Applicability conditions of ISO/IEC 7776 (1995)

Notes:

1. Only DTE to remote DTE will be considered since this is the case applicable to Euroradio
2. “Not applicable” means this case is not possible for Euroradio
3. “shall be used” and “shall not be used” indicate the application conditions for Euroradio
4. “Optional” means this feature can be implemented or not; if implemented it shall be compliant with the specification

Section	Application conditions
Foreword	Annex A (conformance) shall not be used
Introduction	"Protocol Implementation Conformance Statement" shall not be used
§ 1 Scope	<p>Shall be used</p> <p>Only the following features/options shall be used</p> <ul style="list-style-type: none"> • DTE/DTE communication • Start/Stop transmission • Extended (mod 128) operation • Single link procedure <p>Bilateral agreements means: “General agreement for all EuroRadio implementations is made by this application conditions”</p> <p>Clause 7 (conformance) shall not be used</p>
§ 2 Normative references	<p>Shall be used</p> <p>ISO/IEC 7478, X.25, ISO/IEC 9646—1,2:1994 ISO/IEC 646 are not applicable</p>
§ 3 Frame structure	Shall be used. Table 1 (modulo 8) shall not be used
§ 3.1 Flag sequence	Shall be used
§3.2 Address field	Shall be used
§ 3.3 Control field	Shall be used. Basic (modulo 8) operation shall not be used
§3.4 Information field	Shall be used
§ 3.5.1 Transparency Synchronous transmission	Not Applicable
§ 3.5.2 Transparency Start/stop transmission	Shall be used. Control-escape transparency only shall be used
§3.5.2.1 Seven-bit data path transparency	Shall not be used
§ 3.5.2.2 Control-escape transparency	Shall be used

Section	Application conditions
§ 3.5.2.3 Extended transparency	Shall not be used
§ 3.5.2.3.1 Flow-control transparency	Shall not be used
§ 3.5.2.3.2 Control-character octet transparency	Shall not be used
§ 3.6 Frame check sequence (FCS) field	Shall be used
§ 3.7.1 Order of bit transmission	Shall be used The order of transmitting bits within each octet in the information field is to send the least significant bit first.
§ 3.7.2 Start/stop transmission	Shall be used
§ 3.8.1 Invalid frames Synchronous transmission	Not Applicable
§ 3.8.2 Invalid frames Start/stop transmission	Shall be used
§ 3.9.1 Frame abortion Synchronous transmission	Not Applicable
§ 3.9.2 Frame abortion Start/stop transmission	Shall be used
§ 3.10.1 Interframe time fill Synchronous transmission	Not Applicable
§ 3.10.2 Interframe time fill Start/stop transmission	Shall be used. Flags shall not be used as interframe time fill . [FIS 8.2.2.7I]]
§ 3.11.1 Data link channel states Synchronous transmission	Not Applicable
§ 3.11.2.1 Data link channel states Start/stop transmission Active channel state	Channel state shall not be used. Flags shall not be used as interframe time fill in. [FIS 8.2.2.7I]]
§ 3.11.2.2 Data link channel states Start/stop transmission Idle channel state	Channel state shall not be used. Timer T5 shall not be used
§ 4.1.1 Control field formats	Shall be used. Table 3 (Modulo 8 operation) shall not be used
§ 4.1.1.1 Information transfer format — I	Shall be used

Section	Application conditions
§ 4.1.1.2 Supervisory format — S	Shall be used
§ 4.1.1.3 Unnumbered format — U	Shall be used
§ 4.1.2.1 Modulus	Shall be used. Modulo 8 shall not be used.
§ 4.1.2.2.1 Send state variable V(S)	Shall be used
§ 4.1.2.2.2 Send sequence number N(S)	Shall be used
§ 4.1.2.2.3 Receive state variable V(R)	Shall be used
§ 4.1.2.2.4 Receive sequence number N(R)	Shall be used
§ 4.1.2.2.5 Poll/Final bit P/F	Shall be used
§ 4.2 Functions of the poll/final bit	Shall be used
§ 4.3 Commands and responses	Shall be used. Table 5 (Modulo 8) shall not be used. Table 6 (modulo 128): response I frames shall be accepted only with F=1 Supervisory frame REJ shall not be used. Supervisory frame SREJ shall be used as response frame only. Unnumbered information frame UI shall be used
§ 4.3.1 Information (I) command	Shall be used
§ 4.3.2 Receive ready (RR) command and response	Shall be used
§ 4.3.3 Receive not ready (RNR) command and response	Shall be used
§ 4.3.4 Reject (REJ) command and response	Shall not be used
§ 4.3.5 Set asynchronous balanced mode (SABM) command/Set asynchronous balanced mode extended (SABME) command	Shall be used. SABME only shall be used
§ 4.3.6 Disconnect (DISC) command	Shall be used
§ 4.3.7 Unnumbered acknowledgement (UA) response	Shall be used

Section	Application conditions
§ 4.3.8 Disconnected mode (DM) response	Shall be used. An "unsolicited DM" shall not be used. . [FIS 8.2.2.7d)]
§ 4.3.9 Frame reject (FRMR) response	Shall be used. REJ shall be identified as "not implemented". SREJ and UI shall be identified as "implemented". Table 7 (modulo 8) shall not be used.
§ 4.4.1 Busy condition	Shall be used
§ 4.4.2 N(S) sequence error	Shall be used . The first sentence (The information field....shall be discarded) shall not be used. The last sentence shall be used only for the means specified in 4.4.2.1 (Checkpoint recovery) and 4.4.2.3 (Timeout recovery).
§ 4.4.2.1 Checkpoint recovery	Shall be used
§ 4.4.2.2 REJ recovery	Shall not be used. SREJ recovery shall be used instead.
§ 4.4.2.3 Time-out recovery	Shall be used
§ 4.4.3 Invalid frame condition	Shall be used
§ 4.4.4 Frame rejection condition	Shall be used In the case of FRMR reject condition; link reset shall not be used. The receiver of FRMR shall send a DISC frame as a response. [FIS 8.2.2.7e)]
§ 5.1 Procedure for addressing	Shall be used. Single link operation (SLP) only shall be used. The end system initiating the establishment of the B/B _m channel is considered to be the "calling end system". The calling end system plays the DTE role and the called system plays the DCE role in respect to addressing. [FIS 8.2.2.7i)]
§ 5.2 Procedure for the use of the P/F bit	Shall be used
§ 5.3.1 Procedures for link set-up and disconnection Link set-up	Shall be used. The calling end system shall initiate link set-up. [FIS 8.2.2.7j)] SABME only shall be used. The DTE shall never re-initiate link set-up.
§ 5.3.2 Information transfer phase	Shall be used. Timer T4 is optional In the information transfer phase a SABME command shall not be sent, because link resetting is not allowed (see §5.3.1) When receiving a SABME command while in the information transfer phase, the DTE shall send a DISC command and then initiate the release of the B/B _m channel. For backward compatibility response I frames shall be accepted with F=1 (see [ISO 7809] section 5.4.2.1 and 5.4.2.2). [FIS 8.2.2.9]
§ 5.3.3 Link disconnection	Shall be used. Receiving of SABME is not applicable. Optionally, the sender of the DISC can initiate the release of the B/B _m channel.

Section	Application conditions
§ 5.3.4 Disconnected phase	Shall be used. Both DTE shall never re-initiate link set-up. The last two clauses shall not be used.
§ 5.3.5 Collision of unnumbered commands	Shall be used.
§ 5.3.6 Collision of DM response with SABM/SABME or DISC command	Not Applicable An "unsolicited DM" shall not be used. . [FIS 8.2.2.7d]]
§ 5.3.7 Collision of DM responses	Not Applicable.. An "unsolicited DM" shall not be used. . [FIS 8.2.2.7d]]
§ 5.4 Procedures for information transfer	Shall be used. Modulo 8 shall not be used.
§ 5.4.1 Sending I frames	Shall be used
§ 5.4.2 Receiving an I frame	Shall be used. The acknowledgement of the received I- frame shall be sent as soon as possible, in any case not later than T2.
§ 5.4.3 Reception of invalid frames	Shall be used
§ 5.4.4 Reception of out-of-sequence frames	Shall not be used. SREJ recovery action shall be used instead.
§ 5.4.5 Receiving acknowledgment	Shall be used
§ 5.4.6 Receiving a REJ frame	Not Applicable. REJ frame shall not be used A received REJ shall result in a FRMR.
§ 5.4.7 Receiving an RNR frame	Shall be used REJ shall not be used
§ 5.4.8 DTE busy condition	Shall be used REJ shall not be used
§ 5.4.9 Waiting acknowledgement	Shall be used REJ shall not be used. SREJ shall be used instead
§ 5.5 Conditions for link resetting or link re-initialization (link set-up)	Shall be used. Link resetting procedures (5.6.1) shall not be used.
§ 5.6.1 Procedure for link resetting Link reset	Shall not be used.
§ 5.6.2 Procedure for link resetting Request for link reset	Shall be used. Link resetting procedures (5.6.1) shall not be used.
§ 5.7.1.1 Timer T1	Shall be used Table 40 "Layer2 configuration parameters" contains the value(s)

Section	Application conditions
§ 5.7.1.2 Timer T2	Shall be used
§ 5.7.1.3 Timer T3	Optional
§ 5.7.1.4 Parameter T4	Optional
§ 5.7.1.5 Parameter T5	Not Used
§ 5.7.2 Maximum number of transmissions N2	Shall be used. See note in ER FIS §8.3.2.2
§ 5.7.3 Maximum number of bits in an I frame N1	Shall be used
§ 5.7.4 Maximum number of outstanding I frames k	Shall be used
§ 6 Multilink procedure	Not Used
§ 7.1 Static Conformance	Conformance to chapter 7 is not required. Subset 092-1 contains the conformance requirements to ER FIS
§ 7.2 Dynamic Conformance	Conformance to chapter 7 is not required. Subset 092-1 contains the conformance requirements to ER FIS
Annex B	Informative

Annex E (Informative) Version interoperability

Confirmed interoperability issues of EuroRadio implementations based on released versions are listed in this Annex.

E.1 Subset-037 version 2.0.0 and version 2.2.5

Interoperability is not possible.

Nr	ER FIS 200 section	Problem and changes	Comments
1.	7.2.2.1.1 clause 24; 7.2.2.1.1 clause 42	The length of string length is part of the input fields for MAC computation and MAC check. The length itself was not specified in ER FIS 2.0.0. and is specified as 2 octets in ER FIS 2.2.5	different interpretations are possible in v2.0.0; therefore interoperability can only be guaranteed if the implementation conforms to vn2.2.5.
2.	7.2.2.1.2 clause 50	The ETY field should be part of the text strings for peer entity authentication and MAC computation/MAC check. The ETY field was not inserted in procedure3 of ER FIS 2.0.0. and is inserted in procedure3 of ER FIS 2.2.5	different interpretations are possible in v2.0.0; therefore interoperability can only be guaranteed if the implementation conforms to vn2.2.5.
3.	8.2.2 clause 31	Collision of HDLC SABME should be avoided: only the calling party should send a SABME. Calling and called party are allowed to send SABME according to ER FIS 2.0.0. The restriction to calling party is specified in ER FIS 2.2.5	
4.	8.2.2.	A recommendation about interframe time fill-in should be given. Interframe time fill-in was not specified in ER FIS 2.0.0. and is recommended as 'Mark' in ER FIS 2.2.5	Interoperability problems should not exist: it is only a recommendation
5.	8.2.4.6	The ETCS ID type of RIU and RBC was the same one in ER FIS 2.0.0. and is different in ER FIS 2.2.5	
6.	8.3.1	Handling of mobile network ID should be specified at the interface to the application to be able to handle transitions between networks. It was considered as internal task of CFM and therefore not specified in ER FIS 2.0.0. and is specified in ER FIS 2.2.5	Network registration is not supported by SRS 2.2.2: i.e. this parameter will not be used.

E.2 Subset-037 version 2.2.5 and latest version

Nr	ER FIS 225 section	Problem and changes	Comments
1.	2.2.5 section 5.7 (new); section B.5 (new); 8.3.1	[Subset-026] §3.5.6 specifies registration with mobile networks. The solution specified in ER FIS 2.2.5 is not suitable. The respective sections of ER FIS are modified: Service primitives for network registration Handling of mobile network ID	Interoperability problems may exist at GSM-R network border crossing.
2.	8.2.2.6	Different interpretations of the behaviour of Option 8 are possible in version 2.2.5. The latest version of ER FIS clarifies the use of response I frames.	Interoperability of the implementation should be checked
3.	8.2.2	Option 3.2 (multi-selective reject) is used by all ER FIS versions, but different interpretations are possible. The latest version of ER FIS clarifies the use of Option 3.2.	No known problems have been reported so far.
4.	8.3.2.2. Table 39	The recommended values of layer 2 configuration parameters length are modified in latest version of ER FIS.	These parameters will not influence interoperability.