

INTEROPERABILITY UNIT

TAF TSI - ANNEX A.5 :FIGURES AND SEQUENCE DIAGRAMS OF THE TAF TSI MESSAGES

REFERENCE: ERA-TD-100	DOCUMENT TYPE: TECHNICAL DOCUMENT
VERSION: 2.1	TAF TSI
DATE: 10.02.2015	



AMENDMENT RECORD

Version	Date	Section number	Modification/description	Author
1.0	04.02.2011	All	Initial version	Mickael Varga
2.1	10.02.2015	All	Revision of Sequence Diagram and deletion of Train Position message as it was requested by ERA TAF TSI CCM Board on 10.02.2015, Published 18.03.2018	Rodrigo Gutiérrez Domínguez



Important note

The present document belongs to the set of Technical Documents listed in Appendix I 'List of technical documents' of the Commission Regulation (EU) No 1305/2014 of 11 December 2014..



Intended Audience

This document is one of the references to be used by designers and engineers responsible for the proper implementation of the TAF TSI [2] requirements regarding message exchange according chapter 4.2 of the the technical specification for interoperability relating to the telematics applications for freight subsystem of the rail system in the European Union (TSI Telematic Applications for Freight Services).

Evolution of this Document

Distribution:

The Document will be delivered by electronic means in MS-Word format or in PDF Format and published on the ERA Web-site: era.europa.eu.
New versions will be accessible electronically.

Configuration Management:

Any change requests on the content of this document shall be treated through the Change Control Management process prescribed in chapter 7.2 “Change Management” of the Commission Regulation (EU) No 1305/2014. Such a process is supported and managed by the European Railway Agency.



Table of Contents

0. INTRODUCTION	6
0.1. Purpose	6
0.2. Reference documents	6
1. FIGURES	7
1.1 Example of the critical points in Freight Transport.....	7
1.2 Example for train Path request and RU / IM Communication	8
1.3 Scenarios for path booking	9
1.4 Examples for ETI calculation	11
1.5 General Architecture Solution Overview	12
1.6 Access method to the different types of Databases using the common interface	13
2. SEQUENCE DIAGRAM: PATH REQUEST	14
2.1 Sequence diagram path request	14
2.2 Sequence diagram RU cancels a booked path	15
2.3 Sequence Diagram: Path Not Available	16
3. SEQUENCE DIAGRAM: TRAIN PREPARATION	17
4. SEQUENCE DIAGRAM: TRAIN RUNNING FORECAST	18
4.1 Process Description.	18
4.2 Examples.	21
5. SEQUENCE SHIPMENT ETI / ETA.....	25
5.1 Process Description	25
6. SEQUENCE DIAGRAM: WAGON MOVEMENT/INTERCHANGE REPORTING	27



0. INTRODUCTION

0.1. Purpose

This document is the collection of the figures and sequence diagrams to which the TAF TSI [2] refers. It gives support for the right understanding of the processes and functionality prescribed in the TAF TSI [2].

0.2. Reference documents

Ref. N°	Document Reference	Title	Last Issue
[1]	Directive 2008/57/EC	Interoperability of the rail system	17.06.2008
[2]	TAF TSI Regulation No 1305/2014	Commission Regulation (EU) No 1305/2014 of 11 December 2014 on the technical specification for interoperability relating to the telematics applications for freight subsystem of the rail system in the European Union and repealing the Regulation (EC) No 62/2006	11.12.2014
[3]	Directive 2012/34/EU	Directive 2012/34/EU of the European Parliament and of the Council of 21 November 2012 establishing a single European railway area (OJ L 343, 14.12.2012, p. 32).	21.11.2012
[4]	Directive 2004/49/EC	Directive 2004/49/EC of the European Parliament and of the Council of 29 April 2004 on safety on the Community's railways and amending Council Directive 95/18/EC on the licensing of railway undertakings and Directive 2001/14/EC on the allocation of railway infrastructure capacity and the levying of charges for the use of railway infrastructure and safety certification (Railway Safety Directive) (OJ L 164, 30.4.2004, p. 44).	28.11.2009

1. FIGURES

1.1 Example of the critical points in Freight Transport

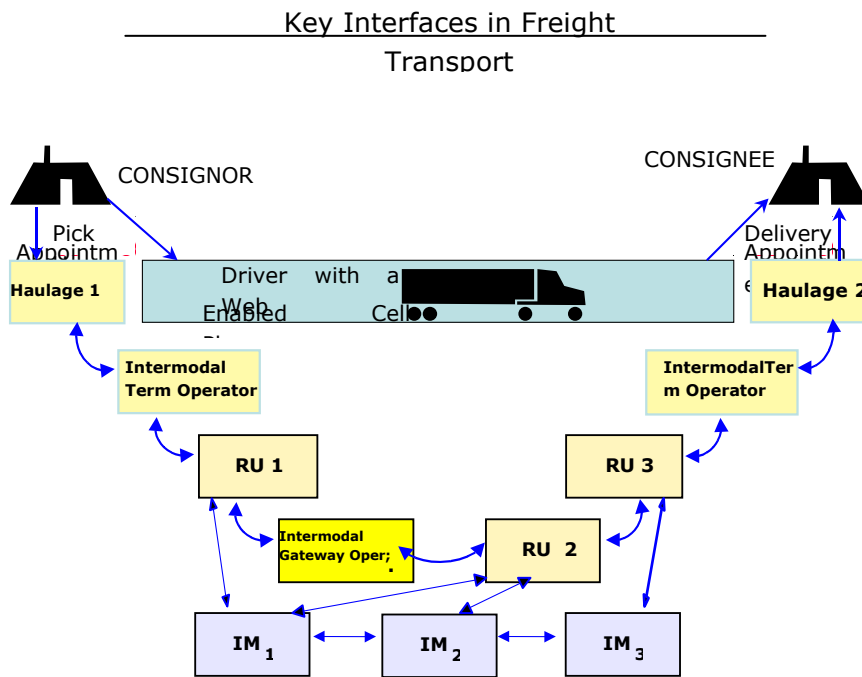

The figure above shows the critical points (interfaces between the various partners involved) in freight transport on road compared with the critical points of freight transport on rail for a simplified scenario.



1.2 Example for train Path request and RU / IM Communication

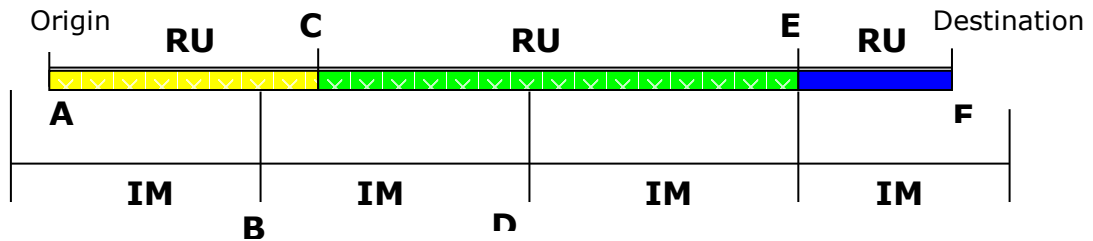

With B, D and E as handover points between IMs and C and E as interchange points between RUs the situation is as follows:

- RU1 has to request a train path A-B from IM1 and B-C from IM2;*
- RU2 has to request a train path C-D from IM2 and D-E from IM3;*
- RU3 has to request a train path E-F from IM4.*

The communication during the train running between RU and IM must always be based on train and path number, whereby the IM communicates with the RU, who has booked the train path on his infrastructure. This means for the example above:

- For the journey section A-B, IM1 communicates with RU1;*
- For the journey section B-C, IM2 communicates with RU1;*
- For the journey section C-D, IM2 communicates with RU2;*
- For the journey section D-E, IM3 communicates with RU2;*
- For the journey section E-F, IM4 communicates with RU3.*

If an RU provides the complete journey A – F (Open Access by RU, no other RUs are involved), then each IM involved communicates directly with this RU only. This “open access” by the RU can be realised by booking the train path via “One Stop Shop” or in sections with each IM directly. The TSI takes account both cases.

1.3 Scenarios for path booking

- **Scenario A:** The RU contacts all involved IMs directly or via the OSS to organise the paths for the complete journey. In this case the RU has also to operate the train on the complete journey according to Article 38 of the Directive 2012/34/EU [3].

a) Path booking via OSS by the RU for Transport Journey from A to F:

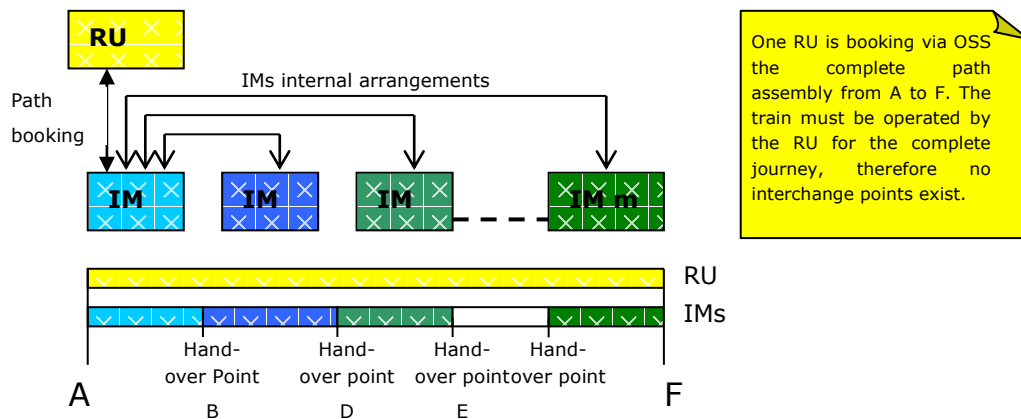

b) Direct path booking by the RU for Transport Journey from A to F:

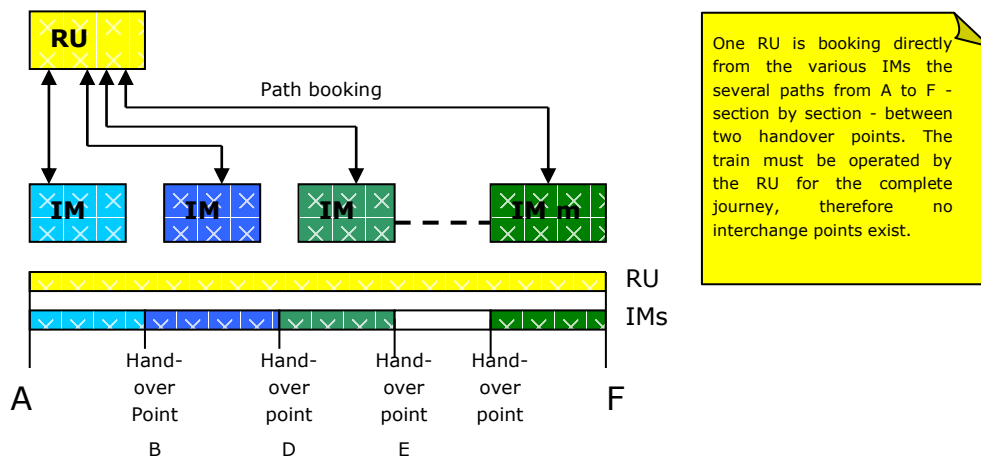

- **Scenario B:** Each RU involved in the Transport Journey from A to F contacts the local IMs directly or via OSS to request a path for the journey section on which it operates the train:

In this example:
 RU 1 is the LRU to co-ordinate the involved RUs

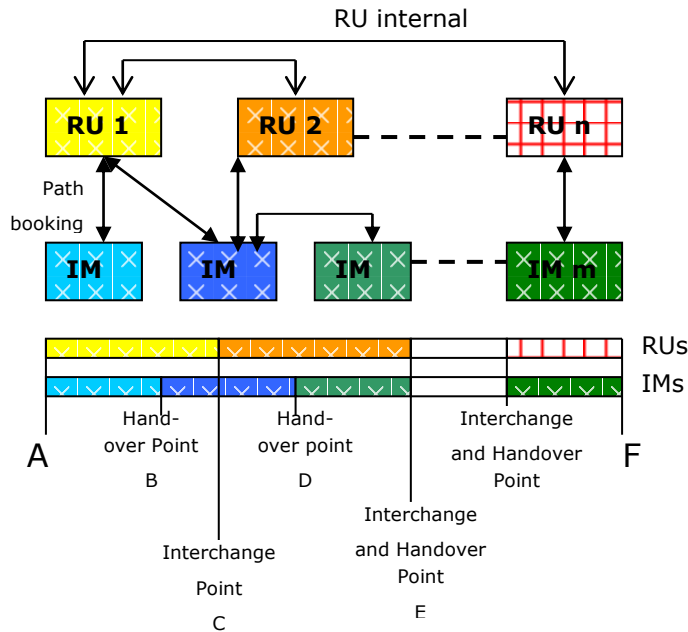

Various RUs request from the various IMs or via OSS only the path(s) for a journey section between two interchange points of the complete journey for a train from A to F. The RUs operate the train on its booked path.

In this example RU1 is booking the paths from A to the interchange point C directly, whereas RU2 is booking the paths from the interchange point C to the next interchange point E via OSS.

Remark: In the execution mode, the IM will always communicate with the RU which has booked the path. Therefore the “path ownership” is important for the message exchange during operation of the train.



1.4 Examples for ETI calculation

Example 1 for calculation of an ETI for LRU 1 and LRU 2 based on TETA from IM2 for interchange point C:

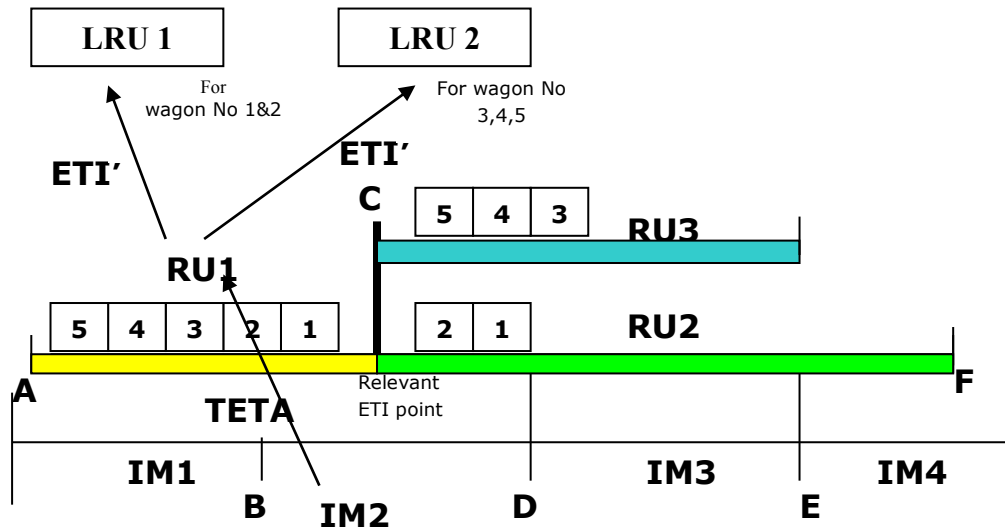

Example 2 for calculation ETI for LRU 1 and LRU 2 based on TETA from IM2 for interchange point C:

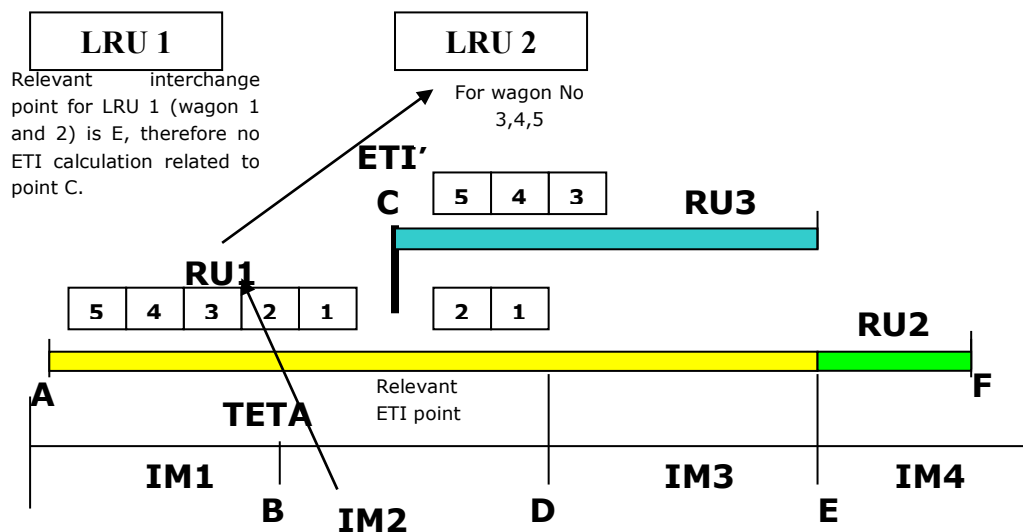



1.5 General Architecture Solution Overview

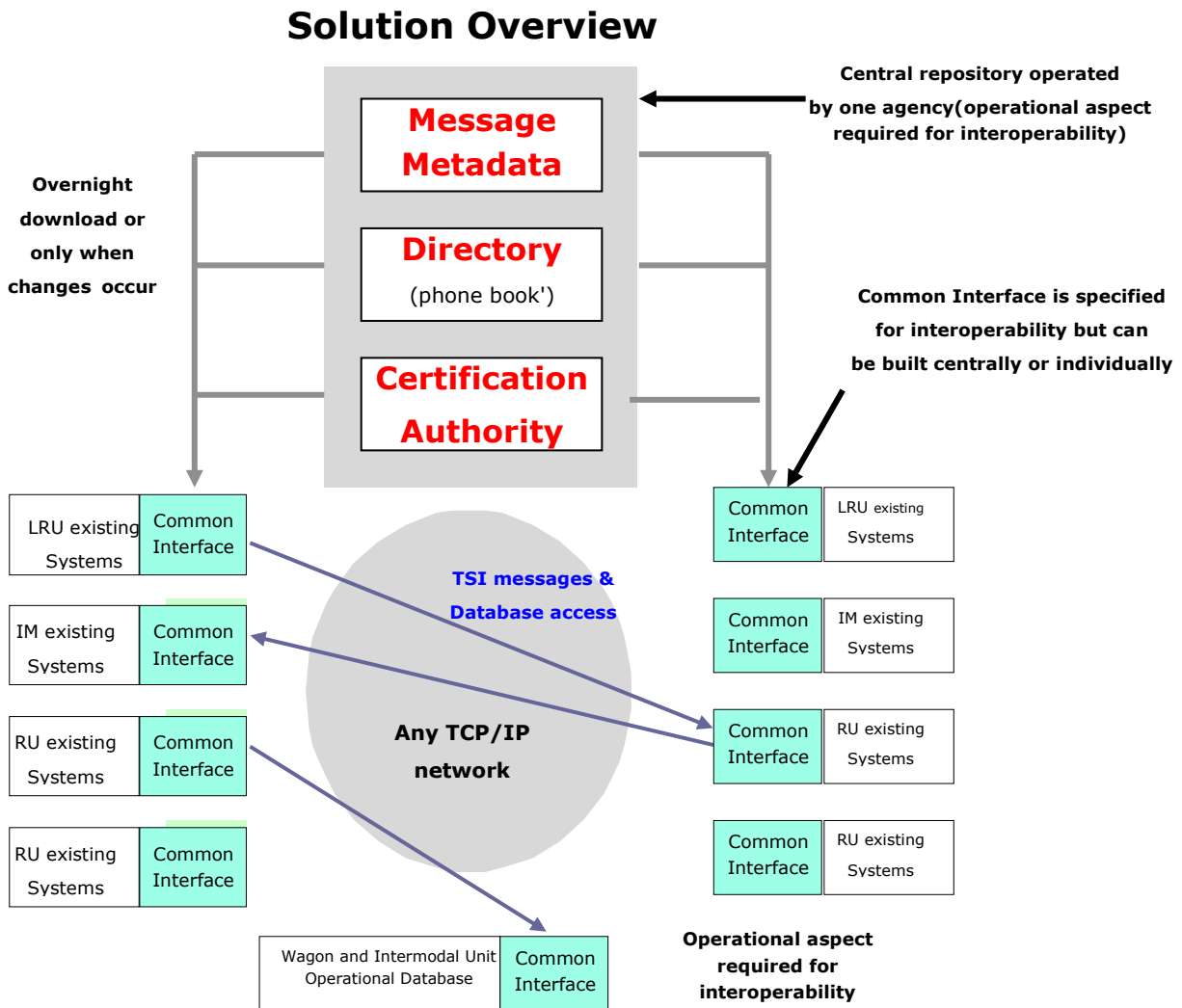



1.6 Access method to the different types of Databases using the common interface

Each instance of the Common Interface will have access to all the data required according the TSI within each RU, IM, etc, whether the relevant Databases are central or individual.

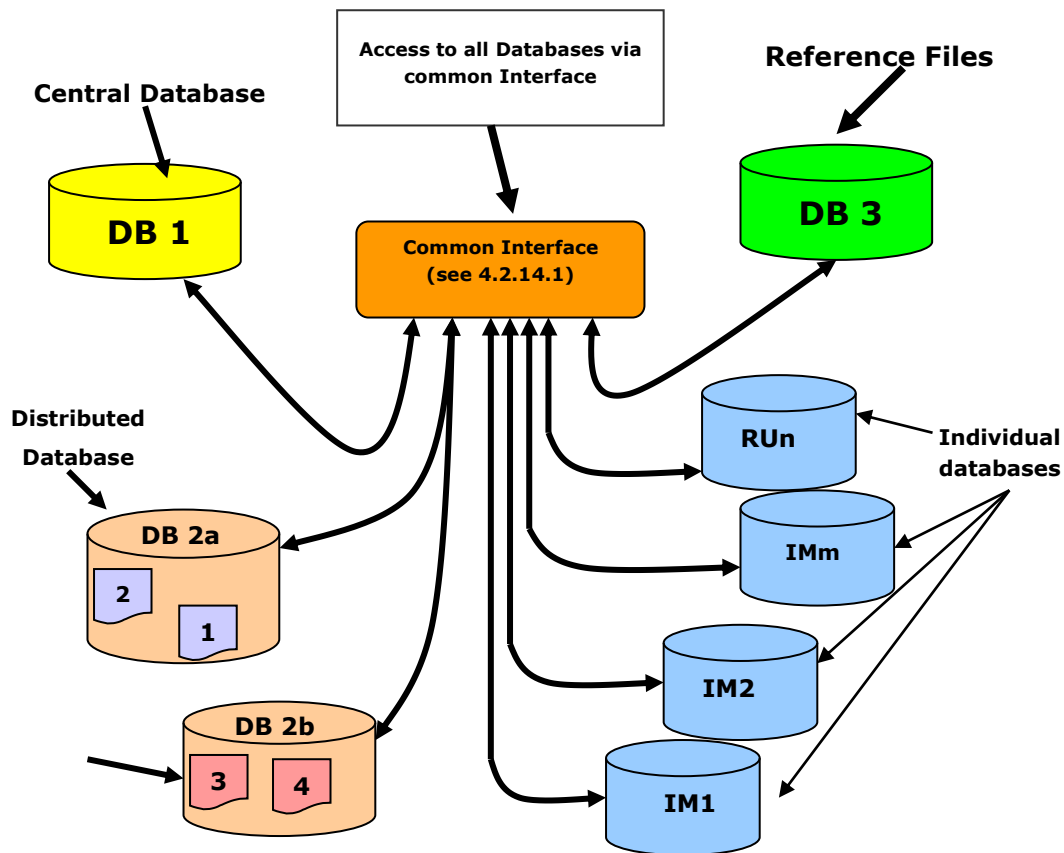



2. SEQUENCE DIAGRAM: PATH REQUEST

2.1 Sequence diagram path request

This Diagram is also valid for Open Access (RU is LRU) and OSS with IM 1 as OSS

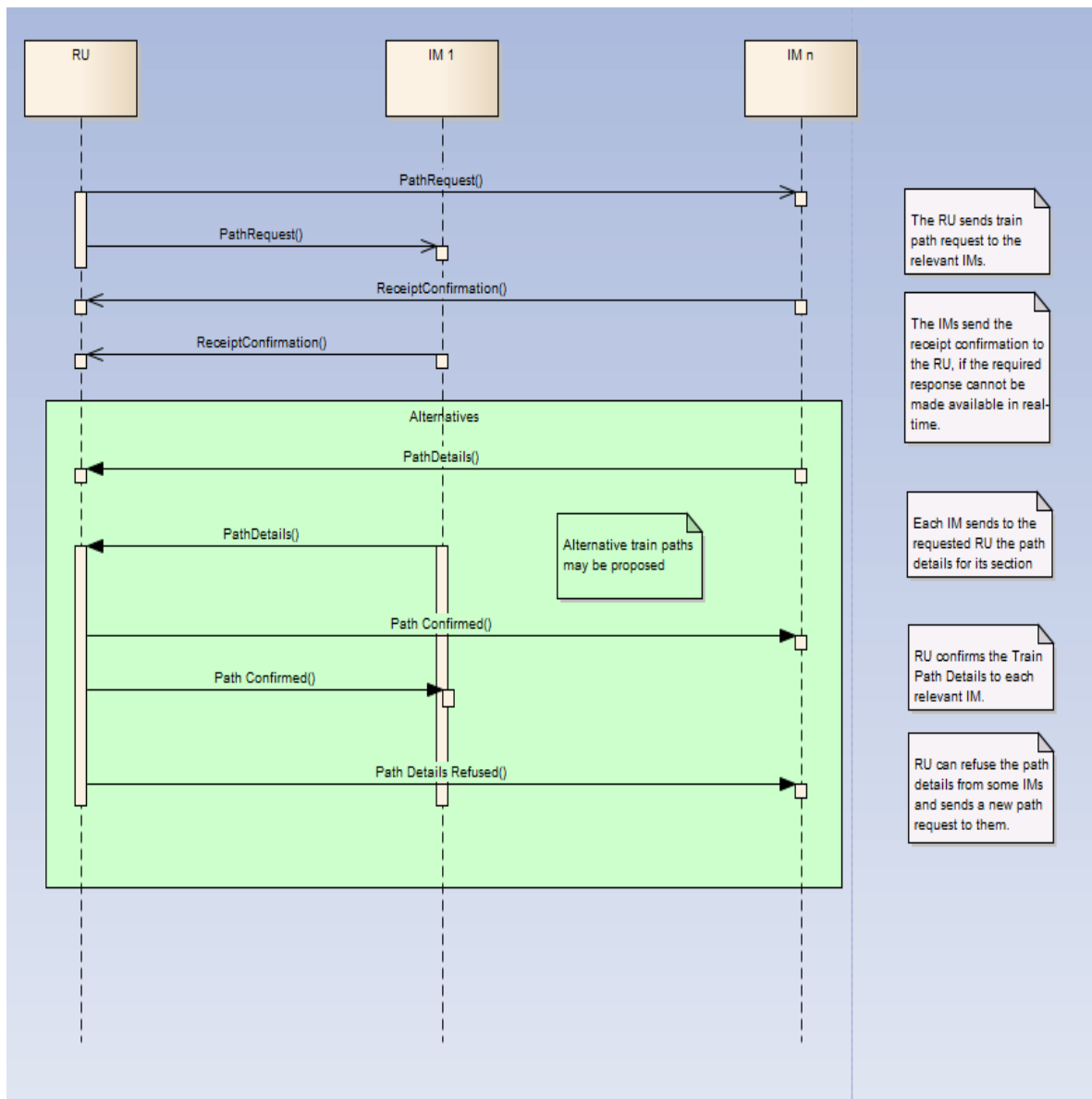



2.2 Sequence diagram RU cancels a booked path

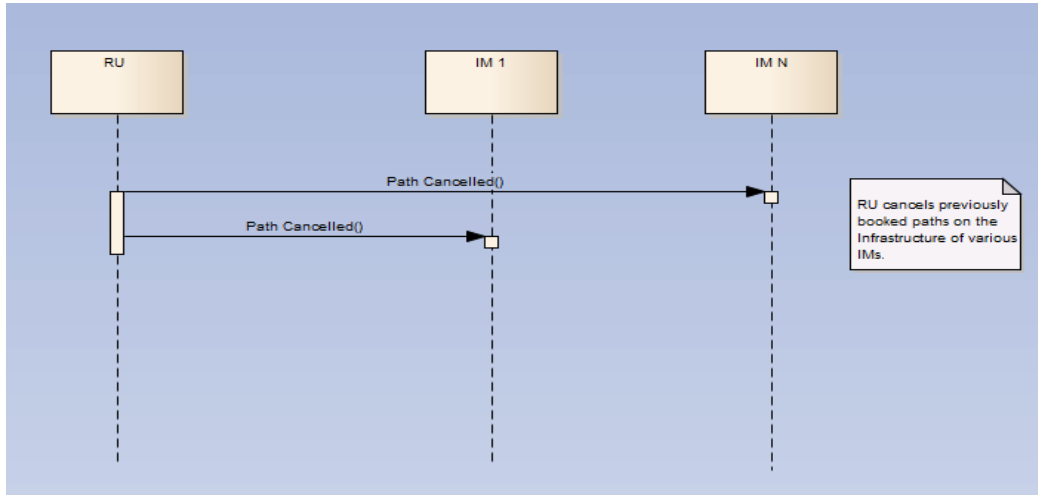



2.3 Sequence Diagram: Path Not Available

This Diagram is also valid for Open Access (RU is LRU) and OSS with IM as OSS:

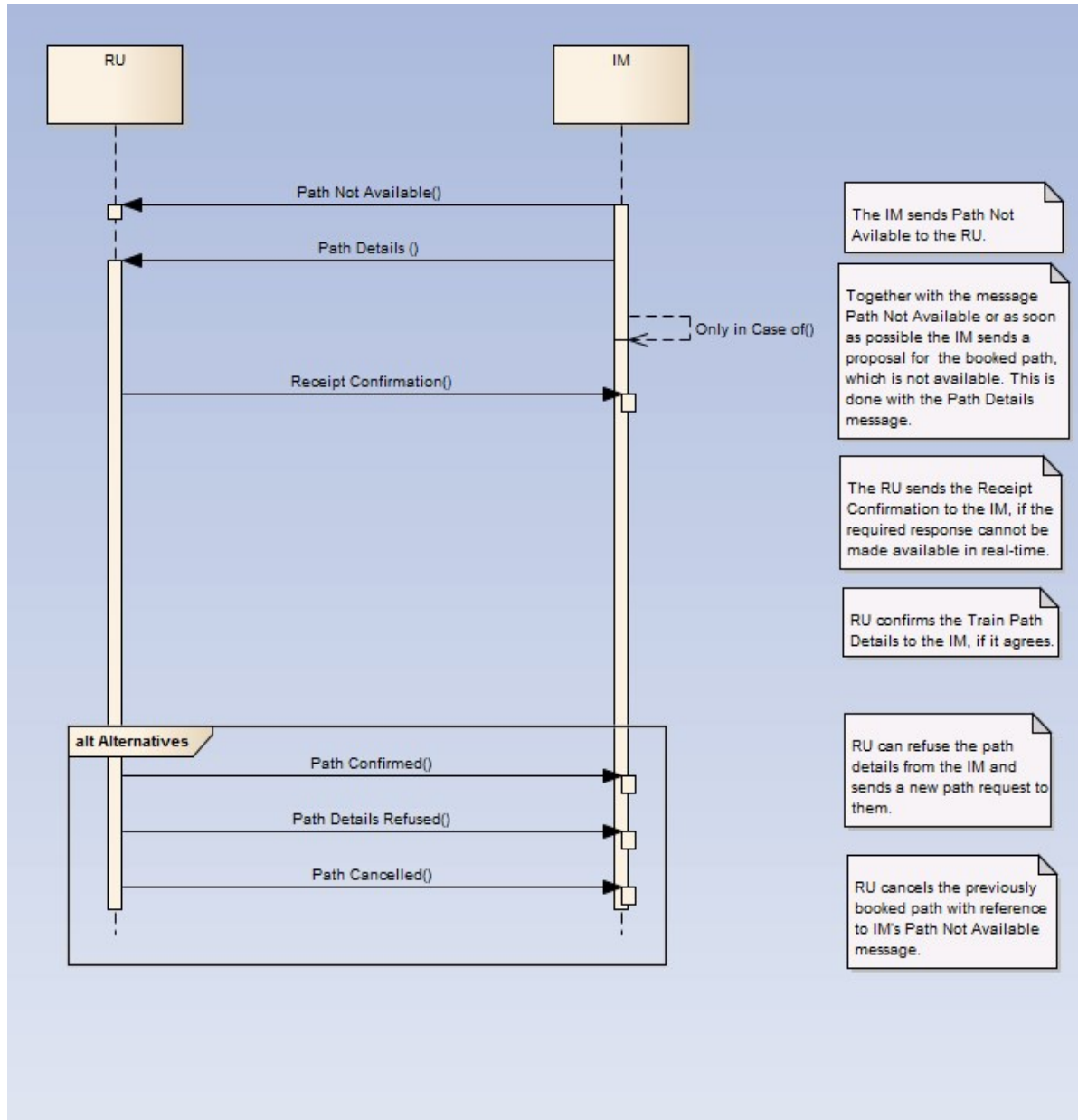



3. SEQUENCE DIAGRAM: TRAIN PREPARATION

This Diagram is also valid for Open Access (RU n is LRU) and OSS with IM 1 as OSS

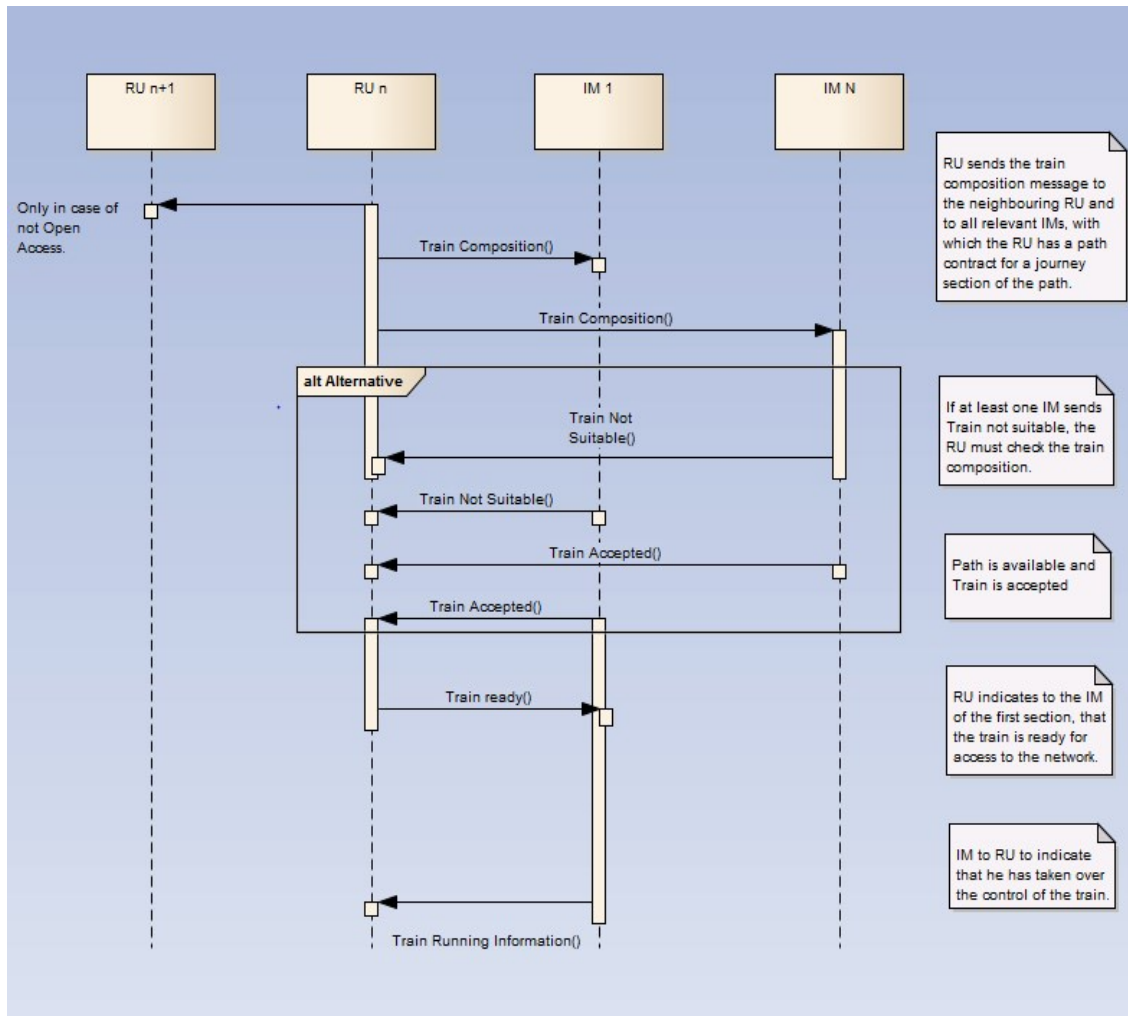

Remark: During the train preparation also a Train Path Not Available message can occur, since this message can be send at any time between the moment the train path is contracted and the departure of the train. This is not included in this diagram.



4. SEQUENCE DIAGRAM: TRAIN RUNNING FORECAST

4.1 Process Description.

For Train Running Forecast and Train Running Information different scenarios are considered, taking into account the various communication relations between RUs and IMs according to the path booking scenarios for chapter 4.2.2.1 (Path Request, Preliminary remarks) of the TAF TSI [2] coretext:

- **Train Approaching a Handover Point between IM n1 and his neighbour IM n2**

It is supposed that the handover point is not also an interchange (only scenario B) nor a handling Point. Thus, the handover point is a point on the booked paths of one RU and the RU has already sent the train composition to IM n2, whilst simultaneously sending this message to IM n1.

IM n1, after departure from the departure point, must send a train running forecast message to IM n2 with the estimated handover time (ETH). This message is simultaneously sent to the RU.

When the train leaves the infrastructure of IM n1 at the handover point this IM sends a Train running information with the actual handover time at this point to its path contracted RU.

When the train arrives on the infrastructure of IM n2 at the handover point this IM sends a Train running information with the actual handover time from this point to its path contracted RU.

- **Train Approaching an Interchange Point between RU 1 and the next RU 2 (only scenario B)**

In the path contract an interchange point must always be defined as a reporting point. (TETAs at reporting points will be generated by the IMs as specified in their contracts with the RUs.)

For this point the IM in charge sends, once the train left the previous reporting point, a train running forecast message with the TETA for this interchange point to the RU which has contracted the path with him (e.g. RU 1). RU 1 transfers this message to the next RU (e.g. RU 2) supposed to take over the train. Additionally, this message is also sent to the Lead RU (LRU) for the transport if there is one and if this is defined in the co-operation contract between both RUs.



If the interchange point is also a handover point between e.g. IM n1 and IM n2, IM n1 sends the train running forecast message already after departure from the departure point or from the previous interchange point to IM n2 with the estimated handover time (ETH). This message is also sent to the RU having contracted the path e.g. RU 1. For the RU the ETH is equal to the TETA at the interchange point. RU 1 transfers this message to its neighbour RU 2 and to the Lead RU or the transport if there is one and if this is defined in the co-operation contract between both RUs.

When the train arrives at an interchange point, the IM must send a Train running information to his path contracted RU, for example RU 1, with the actual time of the arrival at that point.

Before the train leaves the interchange point, RU 2 must send a new train composition message to the IM having allocated the path and follow the departure procedure as defined in chapter 4.2.3 (Train Preparation).

- **Train Approaching a Handling Point of an RU (scenario A)**

A Handling Point must always be defined in the path contract as a reporting point.

For this point the IM in charge must send a train running forecast message with a TETA only if this is specified in contract between IM and RU.

But if the Handling Point is also a handover point between, for example, IM n1 and IM n2, IM n1 must send the train running forecast message after departure from the departure point or from the previous interchange to IM n2 with the estimated handover time (ETH). This message is also sent to the RU. For the RU the ETH is equal to the TETA at the Handling Point.

When the train arrives at the Handling Point, the IM must send a Train running information with the actual time of arrival at this point to the RU.

Before the train leaves the Handling Point the RU and IM must follow the departure procedure as defined in chapter 4.2.3 (Train Preparation).

- **Train arrival at Destination**

When the train arrives at its destination the IM responsible sends a Train running information message with the actual arrival time to the RU which contracted the path.

Remark: In the path contract other locations may also be defined for which a train running forecast with TETA and train running information messages with the actual time are requested. For these points the IM in charge sends these messages as specified in the contract. The further evaluation and processing of the delivered ETHs and TETAs is described in the chapters 4.2.6 (Shipment ETI / ETA) to 4.2.8 (Interchange Reporting).



In the following examples the logical sequence message exchange of the “Train Running Forecast” and “Train Running Information” messages relating to the different communication scenarios are shown with the remark, that regarding the communication relation between RU and IMs for train running, the two path request scenarios A(case A) and A(case B) (chapter 4.2.2.1: Path Request, Preliminary remarks) are identical, because in both cases the IMs know only one RU e.g. RU1 which operates the complete path and is also responsible for new train composition at the handling points. The detailed formats of the messages are defined in Annex II, Annex A index 1. .



4.2 Examples.

- **Example A** according Path request scenario A(a) and A(b) (see chapter 1.3):

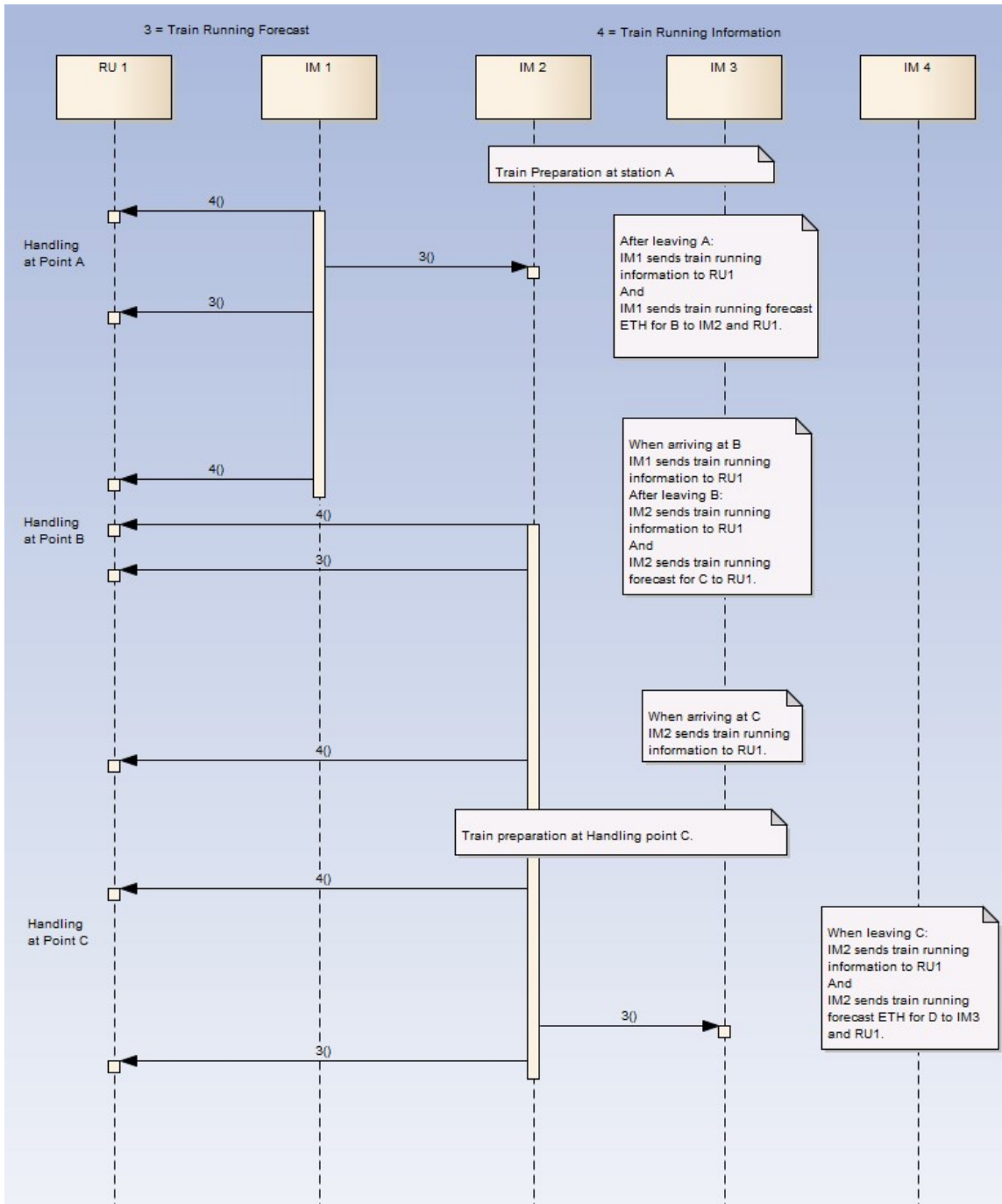



ERA-TD-100: TAF TSI - ANNEX A.5 :FIGURES AND SEQUENCE DIAGRAMS OF THE TAF TSI MESSAGES

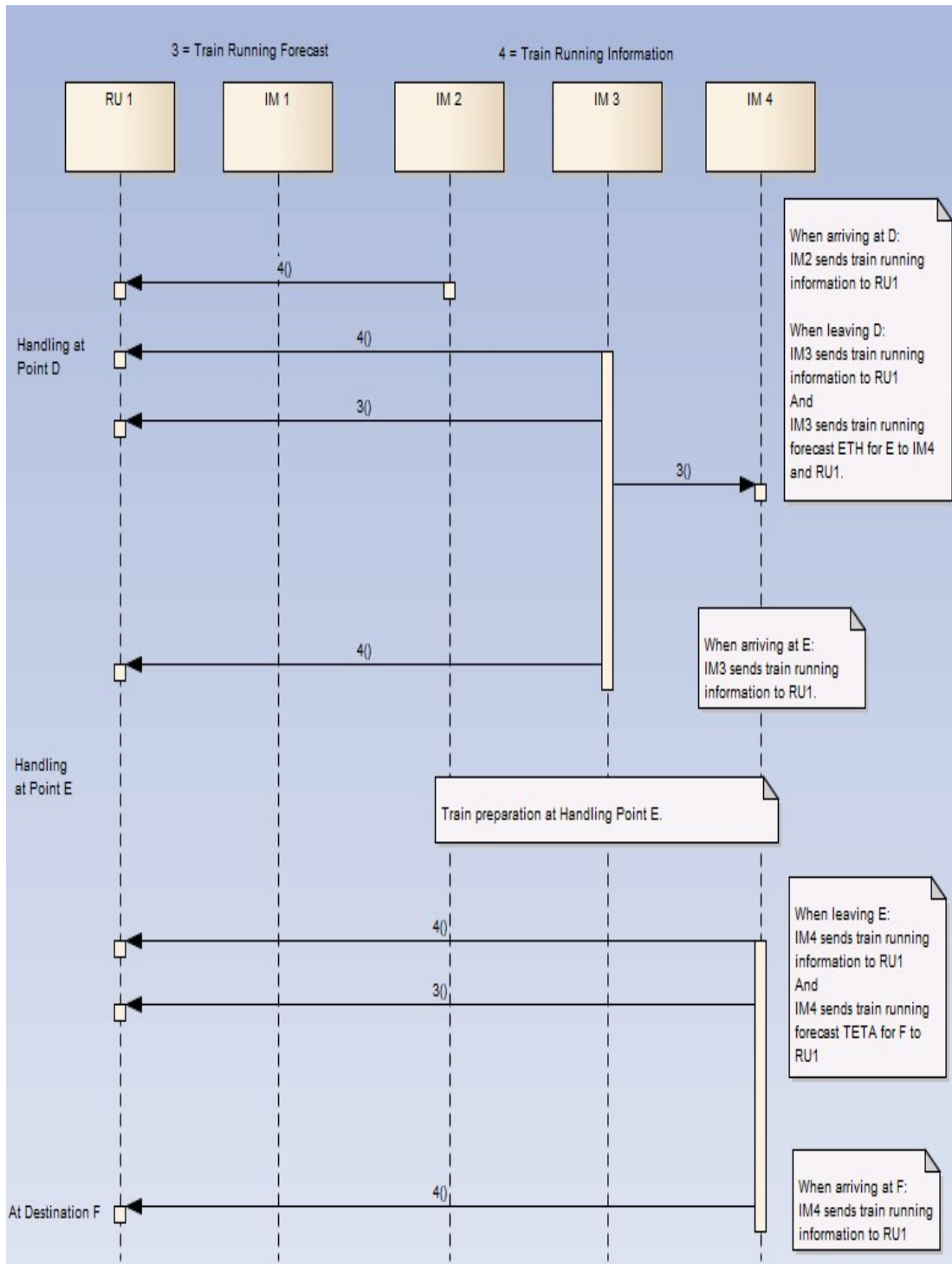



- **Example B** according Path request scenario B (see chapter 1.3):

In this example:
RU 1 is the LRU to co-ordinate the involved RUs.

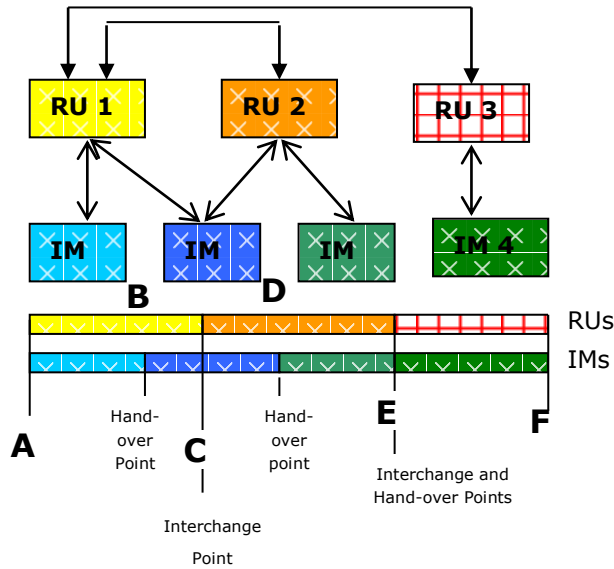

Each RU must know its neighbour RU. This information must be given by the LRU

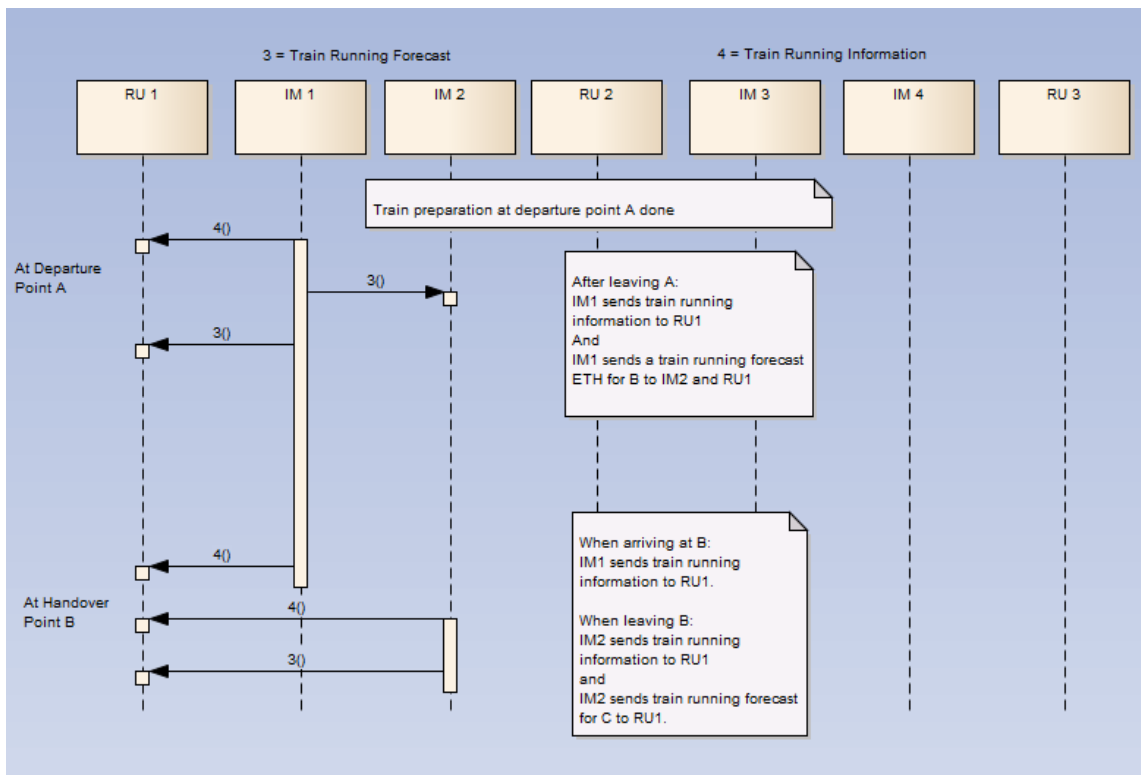



ERA-TD-100: TAF TSI - ANNEX A.5 :FIGURES AND SEQUENCE DIAGRAMS OF THE TAF TSI MESSAGES

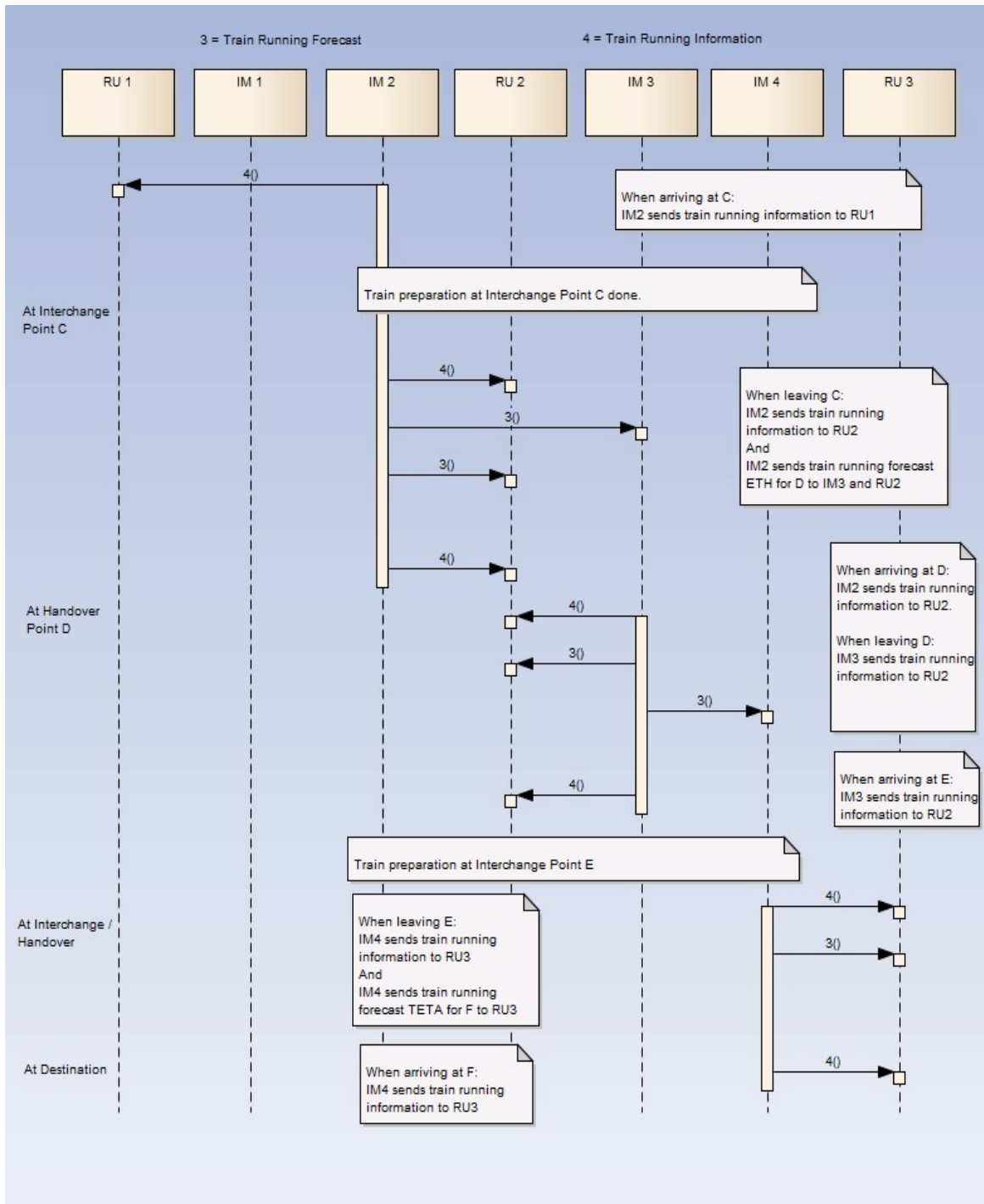



5. SEQUENCE SHIPMENT ETI / ETA

5.1 Process Description

The description of the sequence of exchange of information for Shipment ETI/ETA is explaining through two examples about different scenarios:

- **Example 1:** RU1 has wagon no. 1 and 2 from LRU LRU1 and wagon no. 3 to 5 from LRULRU2 within the same train. At the interchange point C the further transport of the wagon 1 and 2 will be done by RU2 and for the wagon 3 to 5 by RU3. In this case RU1 must calculate related to the interchange point C the ETI for the wagon 1 and 2 and must send these values to LRULRU 1. RU1 must also calculate related to the same interchange point C the ETI for the wagon 3 to 5 and send these values to LRU LRU 2.
- **Example 2:** RU1 has wagon no. 1 and 2 from LRU LRU1 and wagon no. 3 to 5 from LRU LRU2 within the same train. At the interchange point C the further transport of the wagon 3to 5 will be done by RU3 whereas the wagon 1 and 2 remain in the train of RU1 until the interchange point E, where the responsibility for these wagons will be changed to RU2. In this case RU1 must calculate related to the interchange point C only the ETI for the wagon 3 to 5 and must send these values to LRU LRU 2. For the wagons 1 and 2 the interchange point C is not relevant. The next relevant interchange point for these wagons is E and related to this point the RU1 must calculate the ETI and send these values to LRU LRU1.



This Sequence is based on the above example 1 for the interchange point C.

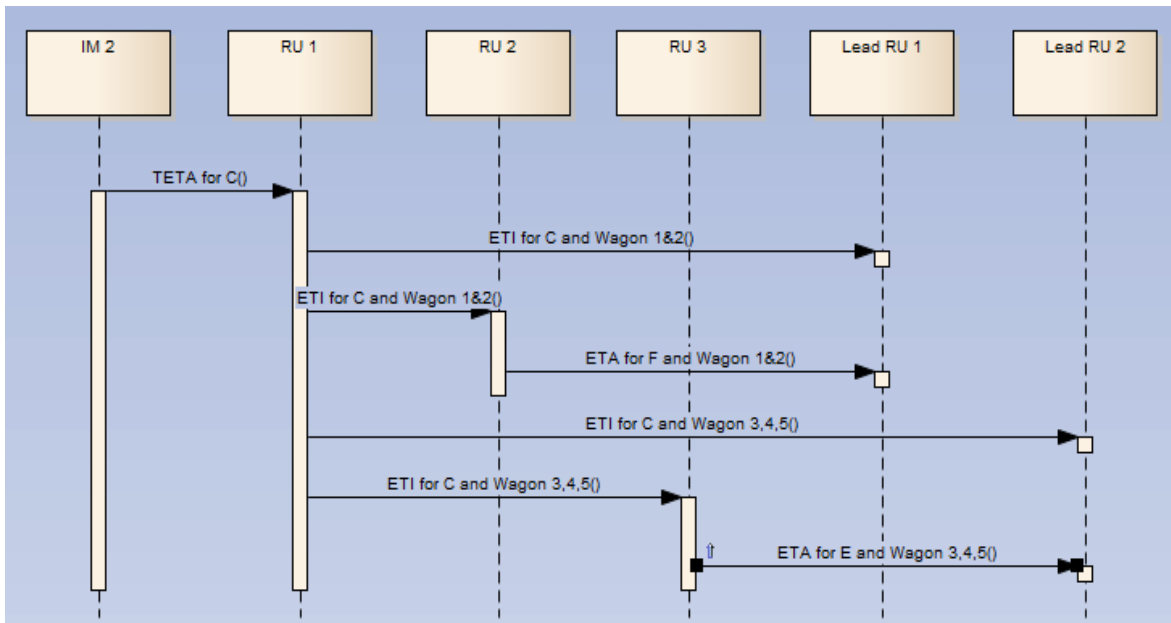
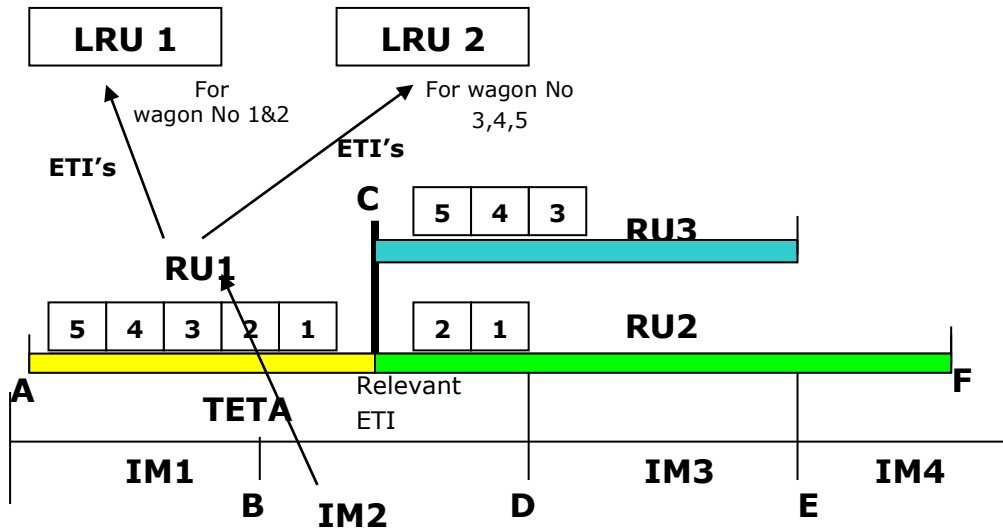

Remark: ETA for the wagons 1&2 is the ETI at F plus the time for delivery at customer siding according to commitment.
ETA for the wagons 3,4,5 is the ETI at E plus the time for delivery at customer siding according to commitment.



6. SEQUENCE DIAGRAM: WAGON MOVEMENT/INTERCHANGE REPORTING

The following Sequence diagram refers to figure 14 (Example 1, ETI Calculation) and considers the handling for the wagon Numbers 1 and 2.

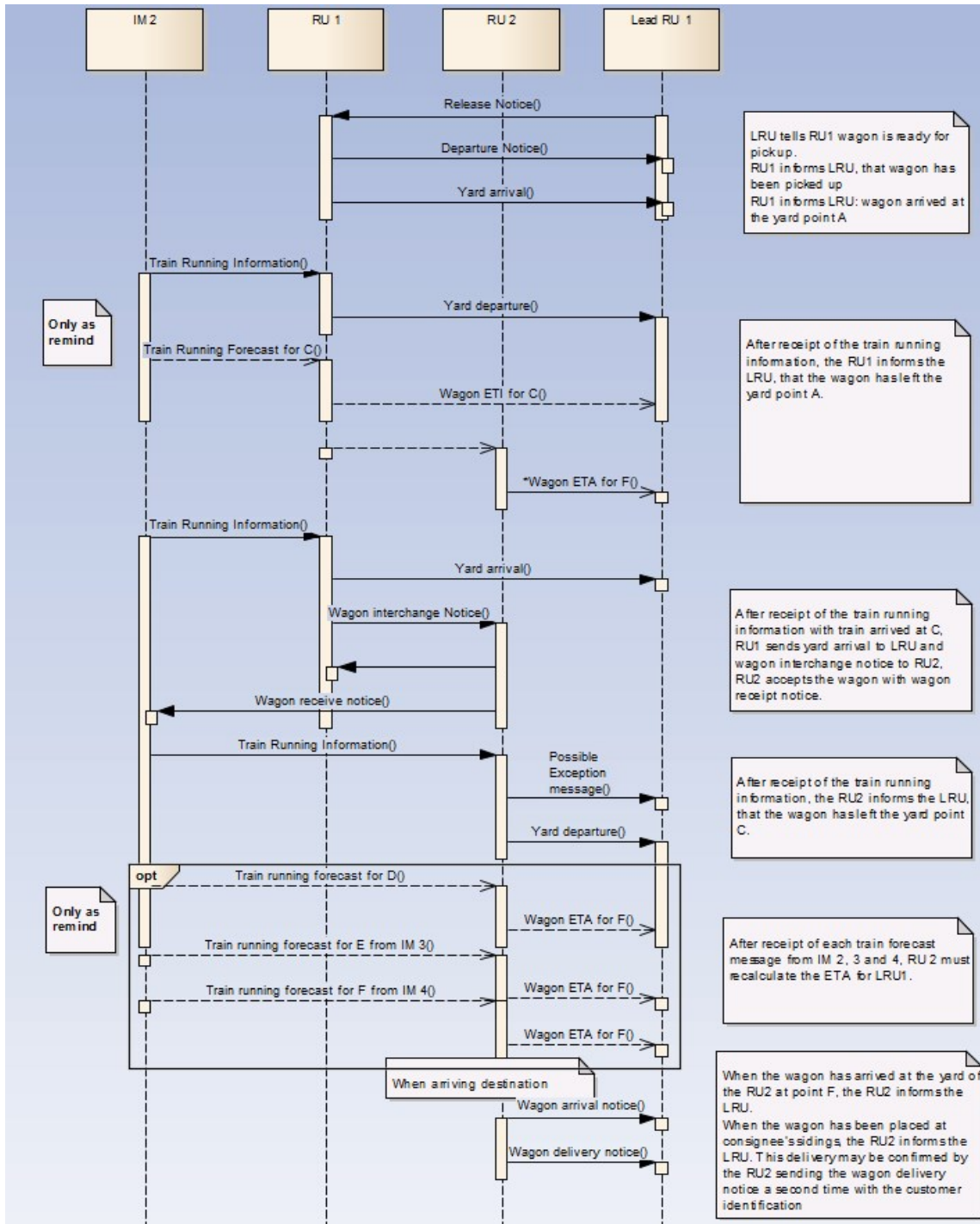



END OF DOCUMENT



Warning

© European Railway Agency 2015