

<b>ERTMS/ETCS UNIT</b>	
<b>INTERFACES BETWEEN CONTROL-COMMAND AND SIGNALLING TRACKSIDE AND OTHER SUBSYSTEMS</b>	
Reference: ERA/ERTMS/033281	Document type:
Version : 5.1	T
Date : 24/09/2025	

## INTERFACES BETWEEN CONTROL-COMMAND AND SIGNALLING TRACKSIDE AND OTHER SUBSYSTEMS

## Amendment record

Version	Date	Section number	Modification/description	Author
0.1	17/02/2010	All	First Draft	
0.2	04/03/2010	All	different modifications proposed	AC
0.3	12/03/2010	All	after EIM comments	AC
0.4	15/06/2010	All	ERA proposal: specific cases deleted and different clarifications	
0.4 modified			first proposal to insert emc requirements for magnetic fields	AC
0.5	29/09/2010	All	review meeting	AC
0.6	11/10/2010	All	language check; requirements for metal free space and use of magnetic brakes; requirements for 1520 mm gauge systems	AC
0.7	26/10/10	All	review meeting	AC
0.8	27/10/10	3.1.4.1; 3.1.4.2; 3.1.5; 3.1.6	editorial improvement	AC
0.9	03/12/10	different sections	Review meeting: axle load; sanding; EMC	AC
0.10	13/01/2011	3.1.4; 3.1.5; 3.2	open point for sand quality; editorial clarifications	AC
0.11	03/02/2011	2	interface table added	AC
0.12	07/03/2011	All	Clarification for DC and low frequency currents Open point for vehicle impedance (moved to section 3.2.2) EMC requirements for magnetic fields	AC
0.13	05/04/2011	3.2.1	EMC WG meeting	AC
0.14	03/05/2011	3.2.1; 3.1.10	Editorial group meeting Draft to EC	AC
0.15	19/05/2011	3.1.10	clarification	AC
1.0	08/06/2011	3.2.1	RISC meeting	AC
1.1	27/09/2012	Table 1 3.1.7.2 3.2.2.2	Proposal for closure of open points	AC
1.2	15/11/2012	3.1.7.2 3.2.2.2	Update of figure and change in text	AC
1.3	17/01/2013	Table 1 3.1.5 3.1.7 3.2.2.2	Editorial improvements and clarifications	AC
1.4	04/02/2013	3.1.6  3.1.7	Deletion of the reference to an obsolete technical document Modification of a value of resistance	AC
1.5	14/03/2013		Editorial improvement	AC
1.6	12/09/2013	3.1.1.3; 3.1.1.4	Alignment with rolling stock TSIs	AC
1.7	11/11/2013	2; 3; 4	Parameters for different track gauges	AC
1.8	13/02/2014		Minor corrections	AC
1.9	20/02/2014		Helsinki meeting	AC
1.10	01/04/2014		Received comments	AC
1.11	16/04/2014		Check before publishing	AC
1.12	23/04/2013		First Maintenance pre-release version	AC
2.0	12/05/2014		Publication	AC
2.1	04/02/2015			
2.2	21/07/2015	2, 3.1.3.1, 3.1.3.2, 3.1.3.3, 3.1.3.4, 3.1.5, 3.1.6, 3.1.7.1, 3.2.2.1	Editorial clarifications	AC

## INTERFACES BETWEEN CONTROL-COMMAND AND SIGNALLING TRACKSIDE AND OTHER SUBSYSTEMS

Version	Date	Section number	Modification/description	Author
2.3	26/11/2015		Updates according to NSA LV comments. Review before new official version	AC
3.0	04/12/2015		Publication	AC
3.1	21/03/2018	All	Inclusion of outcome of technical opinions Closing open points for 1520mm network Integration of Frequency Management for track circuits	DB, MS
3.2	18/04/2018	All	Changes after feedback from TDC WP and CCS WP New chapter 3.3. related to safety	MS
3.3	19/04/2018	3.1	Editorial changes	MS
3.4	13/06/2018	All	Changes discussed during TDC WP 44	MS
3.5	03/08/2018	3.2.2.4/ 3.2.2.6/ 3.2.3	Changes to FM, proposal to close OP Magnetic/Eddy Current Brake	MS,BD
3.6	21/08/2018	3.2.3	Update Magnetic/Eddy Current Brake Axle Counter test procedure	MS,BD
4.0	20/09/2018	All	Changes discussed in TDC 45 Metal Free Space, IC axle counter, Loops	MS
5.0	24/03/2023	All	Changes discussed in TDC 46-75, Closure of all Open Points	MS, BD, CC
5.1	24/09/2025	3.1.7; 3.1.8; 3.2.2.7; 3.2.2.8	Updated parameter for 1520mm. Updated reference to EN standard Update partial application of the Frequency management for vehicles (TDC87)	MS, BD, CC

## INTERFACES BETWEEN CONTROL-COMMAND AND SIGNALLING TRACKSIDE AND OTHER SUBSYSTEMS

---

### Table of Content

1.	INTRODUCTION.....	5
2.	SCOPE .....	6
3.	INTERFACE CHARACTERISTICS .....	8
3.1.	VEHICLE DESIGN AND OPERATION .....	8
3.1.1.	Definitions .....	8
3.1.2.	Axle distances .....	10
3.1.3.	Wheel geometry .....	11
3.1.4.	Use of sanding equipment.....	15
3.1.5.	On-board flange lubrication .....	17
3.1.6.	Use of composite brake blocks.....	17
3.1.7.	Vehicle axle load and metal construction.....	18
3.1.8.	Shunting behaviour and shunting assisting devices.....	18
3.1.9.	Impedance between wheels .....	19
3.1.10.	Intentionally deleted .....	19
3.2.	Electromagnetic compatibility .....	20
3.2.1.	Electromagnetic fields .....	20
3.2.2.	Conducted interference .....	24
3.2.3.	Use of magnetic / eddy current brakes .....	36
3.3.	Design of train detection systems.....	36
3.3.1.	Wrong Side Failures.....	36
4.	CONFORMITY ASSESSMENT .....	37
4.1.	Interoperability Constituent Axle Counter .....	39
5.	Non TSI Compliant Train Detection Systems.....	40
5.1.	Technical characteristics of non TSI compliant train detection systems.....	40
5.2.	Compliance with non TSI compliant train detection systems .....	40
6.	ANNEX A.1 Vehicle metal construction – requirements on the construction.....	41
7.	ANNEX A.2 Verification of Vehicle metal construction - Change of inductivity of trackside loops .....	43
8.	ANNEX B.1 ERA Technical Document for Non TSI compliant train detection systems.....	45

**INTERFACES BETWEEN CONTROL-COMMAND AND SIGNALLING TRACKSIDE AND OTHER SUBSYSTEMS**

---

**1. INTRODUCTION**

This document defines the interoperability requirements that shall be applicable at the interface between the Control-Command and Signalling Track-side and other subsystems (mainly, but not exclusively, rolling stock).

Since different types of trackside equipment originate different compatibility requirements, in this document traceability is provided, by mean of "Explanations" describing the source of each requirement. These "Explanations" are not representing a requirement for trackside subsystems.

Chapter 2 sets out the scope of the document.

Chapter 3 deals with interface requirements between train detection systems and other subsystems like rolling stock subsystem.

Chapter 4 defines conformity assessment requirements for the trackside train detection systems including specific assessment requirements for the interoperability constituent "axle counter".

## INTERFACES BETWEEN CONTROL-COMMAND AND SIGNALLING TRACKSIDE AND OTHER SUBSYSTEMS

### 2. SCOPE

This specification is limited to requirements related to compatibility of train detection systems with other subsystems.

The possible effects of parameters on equipment other than train detection systems are not taken into account (e.g., rolling stock and operation are involved in respecting the requirement on maximum amount of sand, not to disturb track circuits operations, while the possible effects of sand on infrastructure elements like switches are not in the scope of this specification).

The requirements specified in this document have been identified on the basis of compatibility requirements of train detection systems, by reference to the train detection systems intended for use in interoperable lines, i.e.,

1. Axle counters (with electromagnetic wheel detectors)
2. Track circuits
3. Loops
4. Other train detection systems like wheel detectors (e.g., for level crossing operations)

**Train detection systems, which are part of the Control-Command and Signalling Trackside, shall be designed in such a way that they are able to detect a vehicle or consist under the conditions specified by the parameters in this specification.**

In addition, these requirements apply to the relevant other subsystems as identified in the table below.

*Table 1*

Parameter	Subsystem involved				
	CCS on-board	Rolling Stock	Energy	Infra-structure	Operation and Traffic Management
3.1.2.1. Maximum distance between following axles		X			X (train composition)
3.1.2.2. Minimum distance between following axles		X			X (train composition)
3.1.2.3. Minimum distance between first and last axle		X			X (train composition)
3.1.2.4. Maximum distance between front/rear end of train and first/last axle for trains running exclusively on High Speed lines		X			X (train composition)
3.1.2.5. Maximum distance between front/rear end of train and first/last axle for trains running on other lines		X			X (train composition)
3.1.3.1. Geometric dimension of the rim width		X			
3.1.3.2. Minimum wheel diameter		X			
3.1.3.3. Geometric dimension of flange thickness		X			
3.1.3.4. Geometric dimension of the flange height		X			
3.1.3.5. Metal and inductive-component-free space between wheels		X			
3.1.3.6. Wheel material		X			

## INTERFACES BETWEEN CONTROL-COMMAND AND SIGNALLING TRACKSIDE AND OTHER SUBSYSTEMS

Parameter	Subsystem involved				
	CCS on-board	Rolling Stock	Energy	Infra-structure	Operation and Traffic Management
3.1.4.1. Maximum amount of sand		X (technical characteristics of sanding devices)			X (use of sanding devices)
3.1.4.2. Sand characteristics		X			
3.1.5. On-board flange lubrication		X			X (activation of lubrication)
3.1.6. Use of composite brake blocks		X			
3.1.7 Vehicle axle load and metal construction		X			
3.1.8. Shunting behaviour and shunting assisting devices <sup>1)</sup>					
3.1.9. Impedance between wheels		X			X
3.2.1. Electromagnetic fields	X (emissions of Eurobalise antenna)	X			
3.2.2.1. Vehicle impedance		X	X		
3.2.2.4. to 3.2.2.8. Conducted electromagnetic interference limits for traction current		X	X		X (number of trains running in the same power section)
3.2.3. Use of magnetic/eddy current brakes		X (technical characteristics of brakes)			X (operation of brakes)

<sup>1)</sup> such devices are not required by CCS TSI, so no impact for subsystems compliant with TSIs; specific cases or NNTR exist

Unless otherwise indicated, the values of the parameters specified in this document apply for networks with the following nominal track gauges: 1435 mm, 1520 mm, 1524 mm, 1600 mm, and 1668 mm.

If, for a certain parameter, different values apply according to the track gauge, this is explicitly indicated in the corresponding section.

Train detection systems which are compliant with the requirements of this interface document are called TSI compliant train detection systems.

Any existing train detection system being not compliant with the requirements of this interface document is called non-TSI compliant train detection system.

### 3. INTERFACE CHARACTERISTICS

#### 3.1. VEHICLE DESIGN AND OPERATION

##### 3.1.1. Definitions

For the definition of the longitudinal vehicle dimensions Figure 1, (which shows an example for a three-axle twin-bogie vehicle), applies, where:

$a_i$  = distance between following axles, where  $i = 1, 2, 3, \dots, n-1$ , where  $n$  is total number of axles of the vehicle

$b_x$  = distance from first axle ( $b_1$ ) or last axle ( $b_2$ ) to the nearest end of the vehicle, i.e. nearest buffer/nose

$L$  = total length of the vehicle

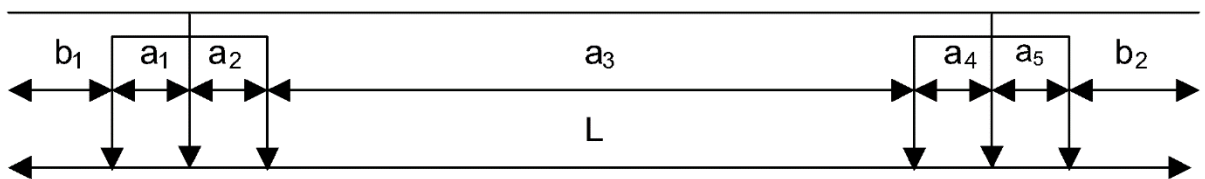

**Figure 1: Longitudinal vehicle dimensions**

If more vehicles are connected in a consist, the characteristics stated in the following part of this section 3.1 and related to  $a_i$  apply to the relevant distance of the axles belonging to each vehicle individually, while the characteristics related to  $b_i$  only apply to the two ends of the complete consist.

For definition of wheel dimensions Figure 2 applies, where:

$D$  = wheel diameter

$B_R + \text{Burr}$  = rim width

$S_d$  = thickness of the flange measured at the line 10mm above the running tread as given in Figure 2

$S_h$  = height of the flange

Other dimensions in Figure 2 are not relevant in this document.

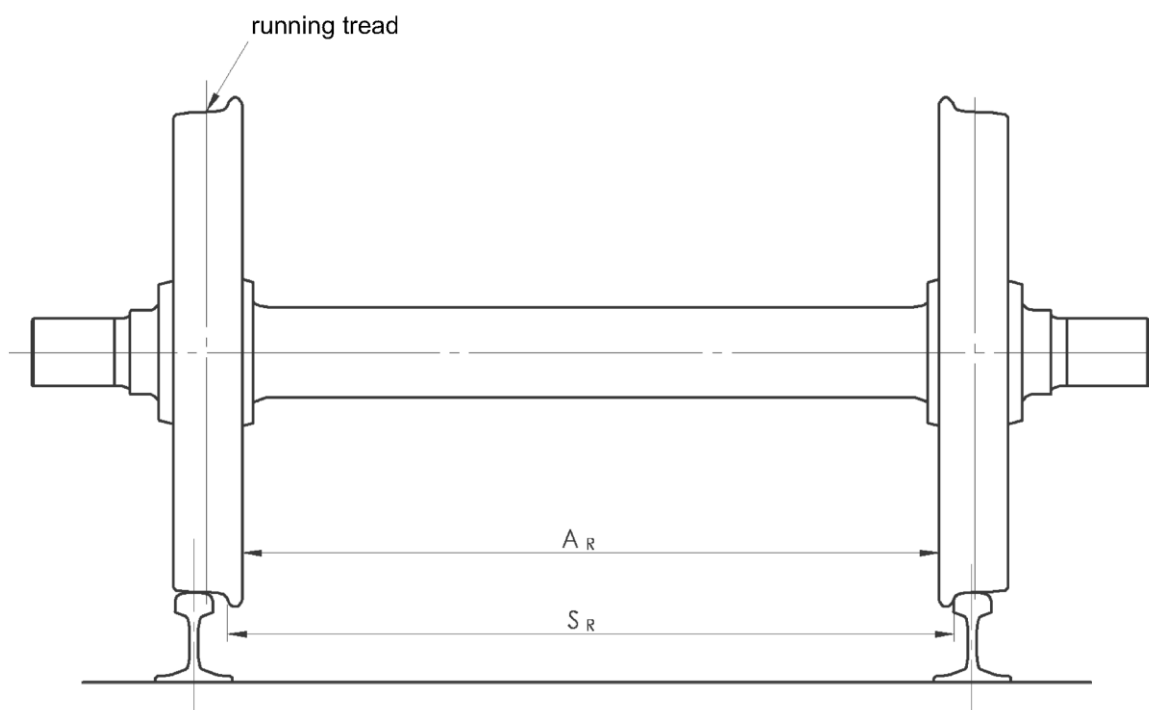
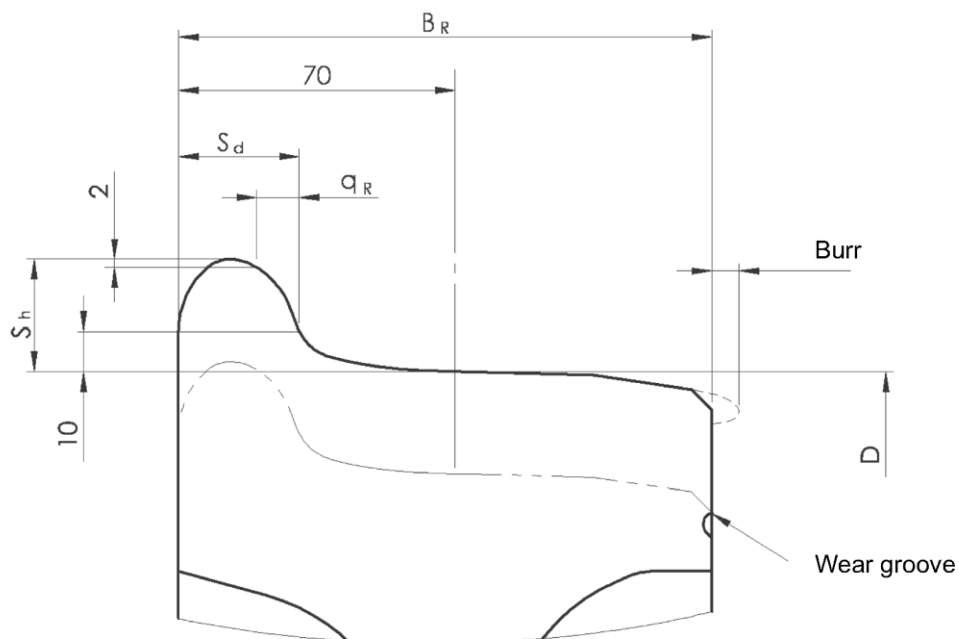
**INTERFACES BETWEEN CONTROL-COMMAND AND SIGNALLING TRACKSIDE AND OTHER SUBSYSTEMS**

*Figure 2: Wheel and wheelset dimensions*

The values quoted in the following paragraphs are absolute limit values including any measurement tolerances.

The term wheelset applies to any pair of opposite wheels, even those not connected by a common axle. Except where stated, wheelset assemblies are assumed to have continuous wheel centres and not have spoke wheels. Any references to wheel sets concern centre of wheels.

## INTERFACES BETWEEN CONTROL-COMMAND AND SIGNALLING TRACKSIDE AND OTHER SUBSYSTEMS

### 3.1.2. Axle distances

#### 3.1.2.1. Maximum distance between following axles

Harmonised parameter for 1435 mm, 1600 mm and 1668 mm track gauge:

The distance  $a_i$  (Figure 1) shall not not exceed 20 000 mm.

Harmonised parameter for 1520 mm and 1524 mm track gauge:

The distance  $a_i$  (Figure 1) shall not not exceed 19 000 mm.

Explanation:

Detection zones with a shorter range may be bridged by a vehicle or a consist with a longer distance between following axles .

#### 3.1.2.2. Minimum distance between following axles

Harmonised parameter:

The minimum axle distances ( $a_i$ ) shall be dependent to the speed of the vehicle  $v$  [km/h] as follows:

Table 2

Maximum Speed $v$ [km/h]	Minimum axle distances $a_i$ [mm]
$v \leq 100$	720
$100 < v \leq 300$	$v \times 7.2$
$300 < v \leq 400$	2160



Figure 3

Explanation:

Axle counter systems shall be able to distinguish the detection of an axle by 2 subsequent counters with sufficient resolution; otherwise the result will be a count-error.

#### 3.1.2.3. Minimum distance between first and last axle

Harmonised parameter:

The distance between first and last axle  $L - (b_1 + b_2)$  (Figure 1) shall be at least 3 000 mm

## INTERFACES BETWEEN CONTROL-COMMAND AND SIGNALLING TRACKSIDE AND OTHER SUBSYSTEMS

---

### Explanation:

The electrical joints between adjacent track circuits may have an area where the detection of an axle of a vehicle is not ensured.

#### 3.1.2.4. *Maximum distance between front/ rear end of train and first/last axle for trains running exclusively on High Speed lines*

### Harmonised parameter:

The distance  $b_x$  (Figure 1) shall not exceed 5 000 mm.

### Explanation:

Signalling systems for High Speed lines may have areas where the distance between a detected first / last axle and the nose / tail of the train is of relevance. High Speed lines are lines with line speeds equal or higher than 250 km/h (traffic code P1).

#### 3.1.2.5. *Maximum distance between front/ rear end of train and first/last axle for trains running on other lines*

Harmonised parameter for 1435 mm, 1524 mm, 1600 mm and 1668 mm track gauge:

The distance  $b_x$  (Figure 1) shall not exceed 4 200 mm.

Harmonised parameter for 1520 mm track gauge:

The distance  $b_x$  (Figure 1) shall not exceed 3 500 mm

### Explanation:

Signalling systems may have areas where the distance between a detected first / last axle and the nose / tail of the train is of relevance.

### 3.1.3. Wheel geometry

#### 3.1.3.1. *Geometric dimension of the rim width*

### Harmonised parameter:

The dimension  $B_R + B_{urr}$  (Figure 2) is (this value is in line with the values specified for geometrical characteristics of wheels in “Locomotives and Passenger rolling stock” and in the “Freight wagons” TSIs)

*Table 3*

*Rim width as a function of the wheel diameter D*

Track gauge [mm]	Wheel diameter D [mm]	Rim width $B_R + B_{urr}$ [mm]
1435	$D \geq 330$	133 to 145
1520	$400 \leq D \leq 1220$	130 to 146
1524	$D \geq 400$	133 to 145
1600	$690 \leq D \leq 1016$	137 to 139
1668	$D \geq 330$	133 to 145

### Explanation:

The detection field of the axle counter is influenced by the wheel passing. The rim width is big enough to influence the field sufficiently in order to ensure appropriate detection.

## INTERFACES BETWEEN CONTROL-COMMAND AND SIGNALLING TRACKSIDE AND OTHER SUBSYSTEMS

### 3.1.3.2. Minimum wheel diameter

Harmonised parameter:

For the maximum speed  $v$ , the dimension  $D$  (Figure 2) shall be at least

*Table 4*

$v$ [km/h]	D [mm] Hooped and Massive Wheels	D [mm] Spoke Wheels
$v \leq 100$	330	600
$100 < v \leq 250$	$150 + 1.8 \times v$	600
$250 < v \leq 350$	$50 + 2.2 \times v$	$50 + 2.2 \times v$
$350 < v \leq 400$	$750 + 0.2 \times v$	$750 + 0.2 \times v$

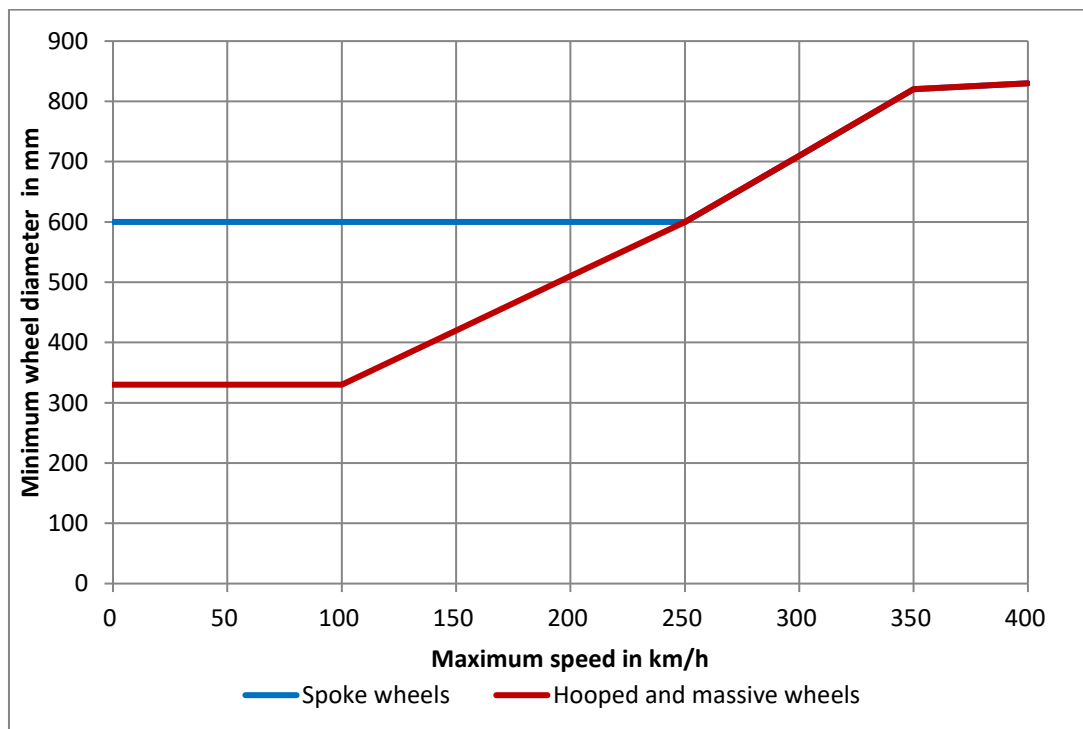

*Figure 4 Minimum wheel diameter*

The requirements for hooped and massive wheels are mandatory, the requirements for spoke wheels are informative.

Explanation:

The length of the influence of the detection field of the axle counter is related to the wheel diameter

Note: EN13979-1:2020 does not cover spoke wheels. It only covers massive (monoblock) and hooped wheels and it can be applied to forged and rolled wheels. For this reason, rolling stock equipped with spoke wheels is not compliant with LOC&PAS TSI. The mandatory scope of assessment of axle counters only includes hooped and massive wheels.

## INTERFACES BETWEEN CONTROL-COMMAND AND SIGNALLING TRACKSIDE AND OTHER SUBSYSTEMS

### 3.1.3.3. Geometric dimension of flange thickness

Harmonised parameter:

The dimension  $S_d$  (Figure 2) shall be (this value is in line with what specified for geometrical characteristics of wheels in “Locomotives and Passenger rolling stock” and in the “Freight wagons” TSIs):

*Table 5*

*Flange thickness as a function of the wheel diameter D*

Track gauge [mm]	Wheel diameter D [mm]	Flange thickness $S_d$ [mm]
1435	$330 \leq D \leq 760$	27.5 to 33
	$760 < D \leq 840$	25.0 to 33
	$D > 840$	22.0 to 33
1520	$400 \leq D \leq 1220$	25 to 33
1524	$400 \leq D \leq 760$	27.5 to 33
	$760 < D \leq 840$	25.0 to 33
	$D > 840$	22.0 to 33
1600	$690 \leq D \leq 1016$	26 to 33
1668	$330 \leq D < 840$	27.5 to 33
	$D \geq 840$	25 to 33

Explanation:

The detection field of the axle counter is influenced by the wheel which passes. The flange thickness has to be big enough to influence the field sufficiently to ensure appropriate detection.

### 3.1.3.4. Geometric dimension of the flange height

Harmonised parameter:

The dimension  $S_h$  (Figure 2) shall be (this value is in line with what specified for geometrical characteristics of wheels in “Locomotives and Passenger rolling stock” and in the “Freight wagons” TSIs):

*Table 6*

*Flange height as a function of the wheel diameter D*

Track gauge [mm]	Wheel diameter D [mm]	Flange height $S_h$ [mm]
1435	$330 \leq D \leq 630$	31.5 to 36
	$630 < D \leq 760$	29.5 to 36
	$D > 760$	27.5 to 36
1520	$400 \leq D \leq 1220$	28 to 37
1524	$400 \leq D \leq 630$	31.5 to 36
	$630 < D \leq 760$	29.5 to 36
	$D > 760$	27.5 to 36
1600	$690 \leq D \leq 1016$	28 to 38
1668	$330 \leq D \leq 630$	31.5 to 36
	$630 < D \leq 760$	29.5 to 36
	$D > 760$	27.5 to 36

Explanation:

The detection field of the axle counter is influenced by the wheel which passes. The flange height has to be big enough to influence the field sufficiently to ensure appropriate detection.

## INTERFACES BETWEEN CONTROL-COMMAND AND SIGNALLING TRACKSIDE AND OTHER SUBSYSTEMS

---

### 3.1.3.5. *Metal and inductive-components-free space between wheels*

Harmonised parameter:

Only wheels and their parts (gearboxes, brake parts) or non-metallic and non-inductive components are permitted to be mounted in the sensitive area of Figure 5.

Sanding pipes of sanding devices and rail guards are allowed to be mounted in a vertical (z-) distance  $\geq 30$  mm above the top of the rail. For sanding pipes below 40 mm to the top of the rail a maximum diameter of 60 mm is allowed.

Other metal parts (e.g. sanding pipe support, heating elements, magnetic track brakes or eddy current brakes in rest position) are allowed to be mounted in a vertical distance  $\geq 40$  mm above the top of the rail. Inside of the shaded area in Figure 5, a metal part with the lateral dimension of maximum 130 mm and maximum of 140 mm for magnetic track brakes, based on the dimensions of magnetic track brakes defined in EN 16207:2014+A1:2019, is allowed.

For magnetic track brakes or eddy current brakes in rest position, the vertical distance requirement ( $\geq 40$  mm above the top of the rail) shall be met:

- Taking into account static vertical deflection of the running gear at maximum load
- With fully allowed wear of the wheel or the maximum wear of the wheel between two re-adjustments.

For metal parts excluding magnetic track and eddy current brakes the vertical distance requirement shall be met:

- under all operational conditions (running in a curve, over switch, ...)
- for the maximum allowed wear of the wheel or the maximum wear of the wheel between two re-adjustments
- for the maximum spring compression of the primary and the secondary vehicle suspensions, considering:
  - a. static load
  - b. additional dynamic stimulation
  - c. tolerances of the stiffness
- for air springs the totally evacuation of the air-suspension bellow („emergency suspension“).

Requirements on steel springs and rubber springs:

Locomotive: Spring compression for an overload of 30% of the suspended mass

Freight wagon: Complete spring compression (till touchdown)

Passenger wagon, baggage wagon, special freight wagon and train set:

Spring compression for an overload of 30% of the suspended mass (maximum load).

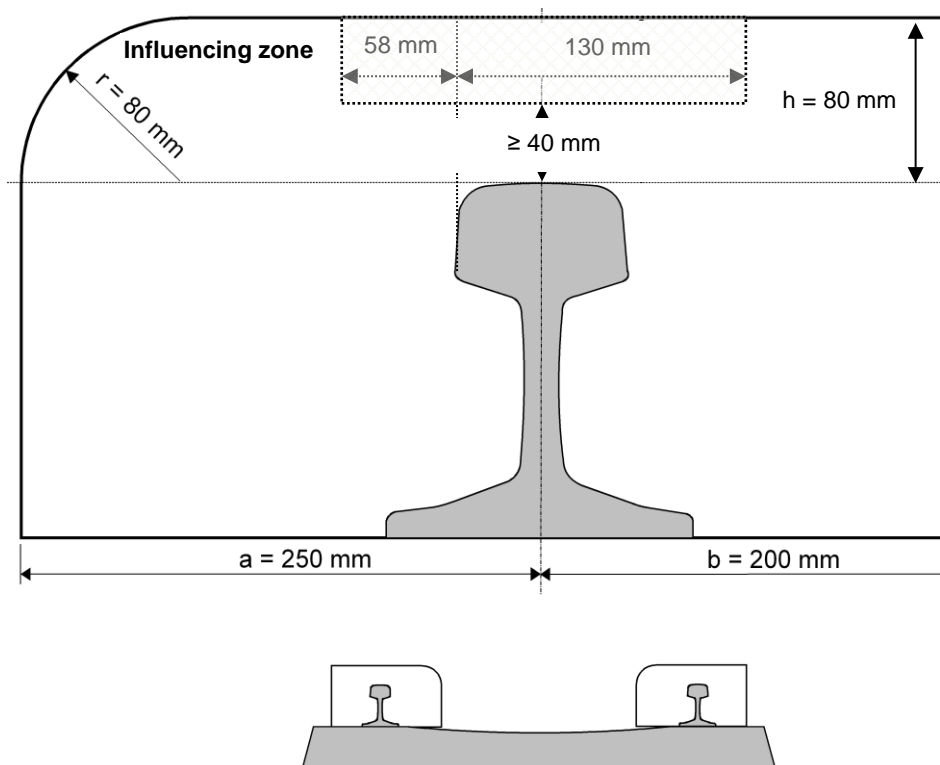

Figure 5: Sensitive area

Explanation:

The principle of axle counters is based on the distortion of an electromagnetic field. The distortion should occur only with the passage of the wheel and not with the passage of surrounding parts of rolling stock, like other ferromagnetic components or inductive coils.

#### 3.1.3.6. Wheel material

Harmonised parameter:

The wheels shall have ferromagnetic characteristics and shall be electrically conducting.

Explanation:

This characteristic is necessary to generate the distortion of the electromagnetic field of axle counters, to ensure appropriate detection.

### 3.1.4. Use of sanding equipment

#### 3.1.4.1. Maximum amount of sand

Harmonised parameter for 1435 mm, 1524 mm, 1600 mm and 1668 mm track gauge:

In case where an automatic sanding function is provided, it shall be possible for the driver to suspend its use.

The maximum amount of sand **per rail per sanding device** (sand at the rail head) shall be 5,0 g/m as measures against wheels being not detected (corresponding with 500g/30s at speed = 12 km/h).

If this value is exceeded at speeds  $\leq 12$  km/h then the maximum amount of sand per sanding device shall be  $\leq 500\text{g}/30\text{s}$ .

## INTERFACES BETWEEN CONTROL-COMMAND AND SIGNALLING TRACKSIDE AND OTHER SUBSYSTEMS

---

The number of active sanding devices shall not exceed the following:

1. For multiple units with distributed sanding devices:
  - with more than 8 wheelsets:  
in the direction of travel one active sanding device in front of a minimum of 7 consecutive wheels without active sanding devices or the maximum amount of sand - regardless of the number of active sanding devices - shall be applied as if there is only **one sanding device**
  - with less than 8 wheelsets:  
in the direction of travel one active sanding device or the maximum amount of sand - regardless of the number of active sanding devices - shall be applied as if there is only **one sanding device**,
  - It is permissible to couple such multiple units and to operate all sanding devices at the coupled ends.
2. For loco-hauled trains
  - a. For braking and for traction: a maximum of 1 active sanding device per bogie per rail
  - b. For locomotives without bogies, this requirement applies to two wheelsets at a time.

Note: The parameters on amount of sand do not apply in case of a coordinated application of an adhesion improving product (which may contain sand) on the rail - on specific lines or entire infrastructure - by assigned rolling stock vehicles, agreed by the infrastructure manager(s) and railway undertaking(s).

Requirements in Specific Cases could mandate specific amount of sand for certain networks.

Harmonised parameter for 1520 mm track gauge:

In case where an automatic sanding function is provided, it shall be possible for the driver to suspend its use.

The allowed amount of sand per sanding device within 60 s shall be:

- 1.2 to 1.5 kg for the front wheelsets
- 0.7 to 1.2 kg for all other wheelsets for passenger and freight locomotives respectively

This parameter shall be taken into account jointly with 3.1.4.2 (Sand Characteristics).

Explanation:

Sand is applied to the tracks to improve braking and traction performance. Sand can create an isolating layer between wheels and rails increasing the contact resistance, with risk of not detecting trains on tracks equipped with track circuits. The use of sand addresses two safety targets: brake and train detection.

### 3.1.4.2. Sand characteristics

Harmonised parameter for 1435 mm, 1520mm, 1524 mm, 1600 mm and 1668 mm track gauge:

**INTERFACES BETWEEN CONTROL-COMMAND AND SIGNALLING TRACKSIDE AND OTHER SUBSYSTEMS**

---

The characteristics of sand applied to the tracks shall be:

- quartz-rich natural sand with a minimum quartz weight of 90%
- the grain shall be sharp-edged and penetrating and – at the very minimum – irregularly shaped with a rough surface
- the sand shall not contain more than 2% of other parts such as humic, clay-like or binding components of foreign substances of any kind such as synthetic plastics
- no pollution material shall be allowed
- the mineral mixture of sand **shall not have** any metallic compounds or salt.

Note: The parameters on sand characteristics do not apply in case of a coordinated application of an adhesion improving product (which may contain sand) on the rail - on specific lines or entire infrastructure - by assigned rolling stock vehicles, agreed by the infrastructure manager(s) and the railway undertaker(s). Requirements in Specific Cases could mandate specific granularity for the sand for certain networks.

Explanation:

The composition of the sand which is used is relevant for the risk of not detecting trains on tracks equipped with track circuits.

### **3.1.5. On-board flange lubrication**

Harmonised parameter:

If the vehicle is equipped with flange lubricators, it shall be possible to activate/deactivate them.

The lubricant shall be biodegradable and shall be compliant with chapter 4 of EN15427-2-1 (2022). Such conditions shall be reported in the operational documentation of the vehicle (type).

Explanation:

Lubricant can create an isolating film between wheels and rails increasing the contact electrical resistance, with risk of not detecting trains on tracks equipped with track circuits. Infrastructure managers might propose the use of certain lubricants for their networks or they might forbid the use of lubricants in certain areas. Biodegradable lubricants only remain for a short period on the rail.

### **3.1.6. Use of composite brake blocks**

Harmonised parameter:

In case composite brake blocks are used, they shall be assessed for effects on the contact electrical resistance between wheel and rail.

Note:

The composite brake blocks suitable for train detection system based on track circuits are those listed in Appendix G of Regulation 321/2013 and those fulfilling the chapter 7 of ERA/TD/2013-02/INT. The application of EN 16452:2015+A1:2019 provides presumption of conformity to this requirement.

Explanation:

Composite brake blocks can create an isolating film between wheels and rails increasing the contact electrical resistance, with risk of not detecting trains on tracks equipped with track circuits.

**INTERFACES BETWEEN CONTROL-COMMAND AND SIGNALLING TRACKSIDE AND OTHER SUBSYSTEMS**

---

**3.1.7. Vehicle axle load and metal construction***3.1.7.1. Vehicle axle load*

Harmonised parameter for 1435 mm, 1520 mm, 1524 mm, 1600 mm and 1668 mm track gauge:

The axle load shall be

1. at least 3,5 t for vehicles with more than 4 axles and wheel tread brakes,
2. at least 4 t for vehicles with 4 axles and wheel tread brakes,
3. at least 5 t for other vehicles (that is, vehicles that do not fall into categories 1 or 2).

In case the minimum axle load is not achieved by the mass of the vehicle in tare condition, conditions for use shall be applied to the wagon requiring to operate it always with a minimum payload or a ballast (for example with an empty loading device). This shall be reported in the Technical file as a condition for use.

Explanation:

A minimum axle load will activate pedals and treadles. Also, minimum axle load will have a beneficiary effect on the resistance between wheel and rails, which is important for the operation of track circuits. Friction elements acting on the surface of wheels contribute to keep them clean and limit the increase of contact resistance.

*3.1.7.2. Vehicle metal construction*

Harmonised parameter for 1435 mm track gauge:

Compatibility with loops shall be shown by analysis of the vehicle metal construction according to the requirements defined in Annex A.1 or by field tests demonstration that the passing vehicle creates sufficient change of inductance of trackside loops according Annex A.2.

Harmonised parameter for 1520 mm, 1524 mm, 1600 mm and 1668 mm track gauge:

No requirement on vehicle metal construction exists.

Explanation:

This parameter specifies the requirements on the metal construction of a vehicle ensuring its detection by trackside inductive loops.

**3.1.8. Shunting behaviour and shunting assisting devices**

Harmonised parameter for 1435 mm, 1524 mm, 1600 mm and 1668 mm track gauge:

The use of shunting assisting devices is not required.

Harmonised parameter for 1520 mm track gauge:

The use of shunting assisting devices is required for 2-axles traction vehicles if the axle load is less than 11 t.

Note: Specific Cases could mandate requirements for demonstrating the shunting behaviour and/or improving the shunting behaviour between wheel and rail for certain networks.

Explanation:

Shunting assisting devices can improve the shunting behaviour between wheel and rail.

### **3.1.9. Impedance between wheels**

Harmonised parameter:

The electrical resistance between the running surfaces of the opposite wheels of a wheelset shall not exceed 0.05 Ohm, measured by a voltage between 1.8 VDC and 2.0 VDC (open circuit).

Explanation:

A track circuit is only able to detect rolling stock if the impedance between rails does not exceed a certain value, given by the impedance of the opposite wheels of the wheelsets and the contact resistance at the wheel-rail surface.

The interface requirement given here is only related to the electrical resistance between the running surfaces of the opposite wheels of a wheelset.

Remark: operational rules may apply to ensure that a sufficiently low value of the contact resistance is maintained during service: see 3.1.4 (Use of sanding equipment), 3.1.5 (On board flange lubrication) and 3.1.6 (Use of composite brake blocks)

### **3.1.10. Intentionally deleted**

### 3.2. Electromagnetic compatibility

The requirements related to electromagnetic compatibility are expressed by means of “frequency management”, the purpose of which is to define the frequency ranges and the associated limits required for compatibility between rolling stock and track-side equipment.

The requirements defined in chapter 3.2 are per Influencing Unit.

The Influencing Unit covers the complete train composition (traction units + wagons/coaches) producing maximum interference (current, magnetic field). The maximum interference of combinations of traction units including coaches and freight wagons, traction subsystems and auxiliary systems can be assessed by using summation rules.

Chapter 3.2.1, Electromagnetic fields, relates on the compatibility of vehicles with punctually working train detection systems like axle counters.

Chapter 3.2.2, Conducted Interference, relates on the compatibility with track circuits which detects vehicles along a certain track section length.

#### 3.2.1. Electromagnetic fields

##### 3.2.1.1. Frequency management

The compatibility requirements specified in this section shall apply for 1435 mm, 1600 mm, 1520 mm, 1524 mm and 1668 mm track gauge network. The frequency management defines three frequency bands:

1. 27 kHz – 52 kHz for band 1
2. 234 kHz – 363 kHz for band 2
3. 740 kHz – 1250 kHz for band 3

The subsequent figures illustrate the vehicle emission limits for x, y and z directions.

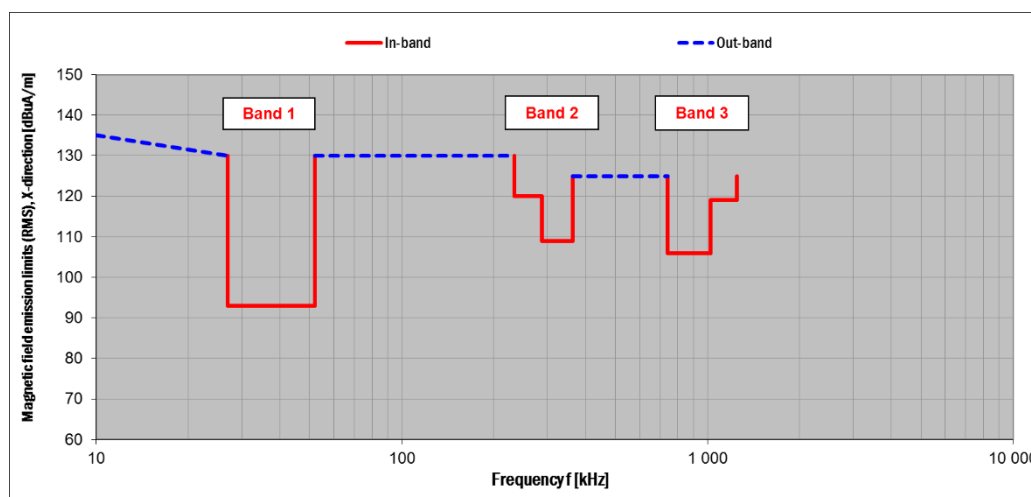

Figure 6: Vehicle emission limits for X direction

## INTERFACES BETWEEN CONTROL-COMMAND AND SIGNALLING TRACKSIDE AND OTHER SUBSYSTEMS

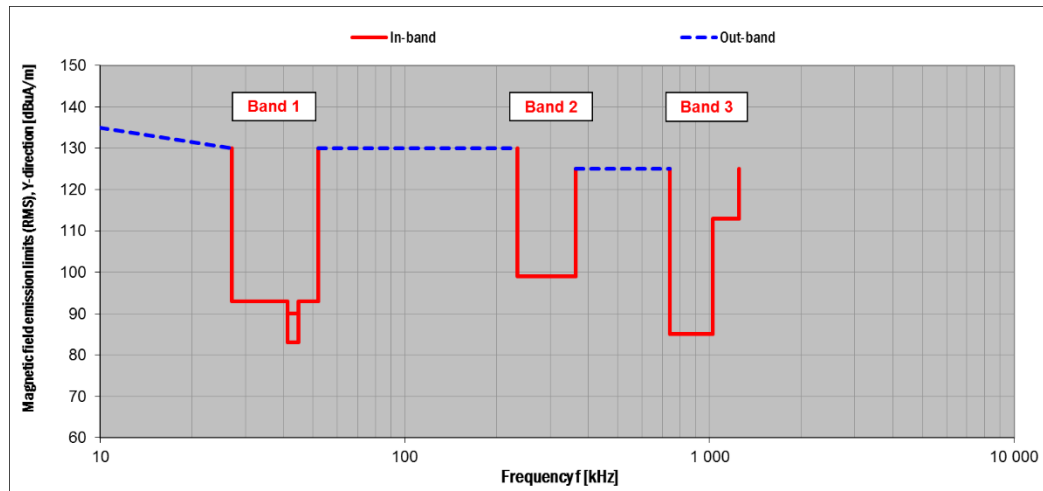

Figure 7: Vehicle emission limits for Y direction

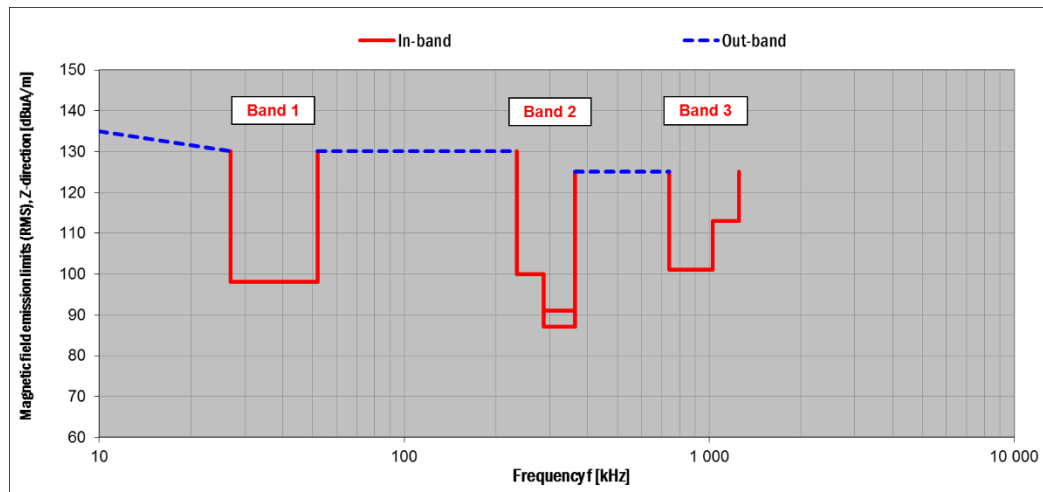

Figure 8: Vehicle emission limits for Z direction

### Explanation:

The magnetic fields generated by rolling stock can potentially interfere with the operation of train detection systems.

#### 3.2.1.2. Vehicle emission limits and evaluation parameters

The limits and associated parameters for the evaluation of rolling stock emissions against the requirements in 3.2.1.1 are provided in the following table 7. For in-band evaluation with band-pass filters a 20 % overlap of the 3 dB-bandwidth and a time overlapping of 75 % shall be required.

Compatibility with in-band limits can also be demonstrated by broadband evaluation using Fast Fourier Transformation with Hanning window, 75% of time overlapping and time windows of 1 ms for Band 1 and 0.5 ms for Band 2 and Band 3.

## INTERFACES BETWEEN CONTROL-COMMAND AND SIGNALLING TRACKSIDE AND OTHER SUBSYSTEMS

Table 7

Band	Frequency range defined by the centre frequency [kHz]	Emission limit X Axis [dB $\mu$ A/m] (RMS)	Emission limit Y Axis [dB $\mu$ A/m] (RMS)	Emission limit Z Axis [dB $\mu$ A/m] (RMS)	Evaluation method**	Filter order (Butterworth) and 3 dB-bandwidth	Evaluation parameters
Out of band	10 to 27	straight line from 135 to 130 in dB/log(f)	straight line from 135 to 130 in dB/log(f)	straight line from 135 to 130 in dB/log(f)	FFT		Record time 1 ms, Hanning window, 50% overlap, max hold
Band 1	27 to 41.2 and 44.8 to 52	93	93	98	BP	4 <sup>th</sup> order 300 Hz	20% overlap (3dB points) integration time: 1ms
Band 1	41.2 to 44.8	93	83*/90*	98	BP	4 <sup>th</sup> order 320 Hz	20% overlap (3dB points) integration time: 1ms
Out of band	52 to 234	130	130	130	FFT		Record time 1ms, Hanning window, 50% overlap, max hold
Band 2	234 to 287	120	99	100	BP	4 <sup>th</sup> order; 7500 Hz	20% overlap (3dB-points), integration time: 1.5 ms
Band 2	287 to 363	109	99	91	BP	4 <sup>th</sup> order; 7500 Hz	20% overlap (3dB-points), integration time 1.5 ms
Band 2	287 to 363	--	--	87	BP	4 <sup>th</sup> order; 4000 Hz	20% overlap (3dB-points), integration time: 1.5 ms
Out of band	363 to 740	125	125	125	FFT		record time 1ms, Hanning window, 50% overlap, max hold
Band 3	740 to 1026	106	85	101	BP	4 <sup>th</sup> order; 10 kHz	20% overlap (3dB-points), integration time: 1.5 ms
Band 3	1026 to 1250	119	113	113	BP	4 <sup>th</sup> order; 10 kHz	20% overlap (3dB-points), integration time 1.5 ms

\* 90 dB $\mu$ A/m for emissions under the train, defined by the distance between the middle of the first and the last axle of the train + 0.5m on both sides, independently of the radius of the wheels. See Figure 9 below.

83 dB $\mu$ A/m for emissions measured before the first axle and after the last axle of the train has passed over the measurement sensor, see Figure 9 below.

\*\* FFT= Fast Fourier Transformation; BP= Band-pass Filtering.

## INTERFACES BETWEEN CONTROL-COMMAND AND SIGNALLING TRACKSIDE AND OTHER SUBSYSTEMS

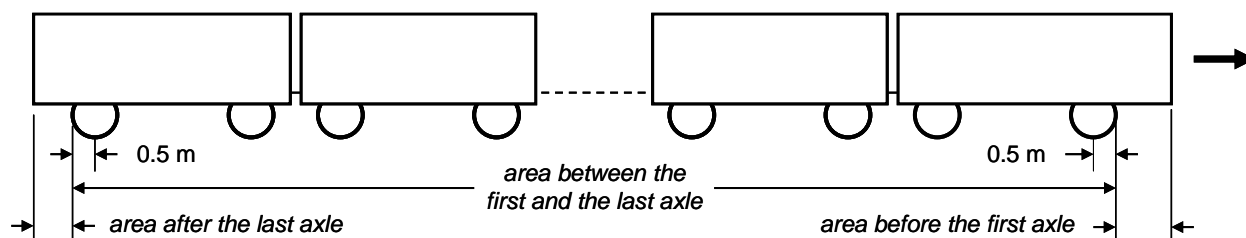

Figure 9

The uncertainty of the whole measurement chain shall be no more than +/- 3 dB of the defined magnetic field limit.

### 3.2.1.3. Evaluation of exceedances of limits defined in Table 7.

In case there are exceedances of the limits specified in Table 7 shorter than the integration time and the Minimum time interval between two exceedances is greater than the integration time  $T_{int}$  specified in Table 7, further evaluation can be done using shorter integration time as defined in Table 8.

Table 8

Frequency range	Field direction	Increasing of magnetic field limits for a reduced integration time of $0,5 \times T_{int}$ [dB]	Increasing of magnetic field limits for a reduced integration time of $0,25 \times T_{int}$ [dB]
27 to 52 kHz	X	2	6
27 to 52 kHz	Y, Z	6	12
234 to 287 kHz	X, Y, Z	6	12
287 to 363 kHz	X, Y, Z	3	6
740 to 1026 kHz	X, Y, Z	6	12
1026 to 1260 kHz	X, Y, Z	0	0

### 3.2.1.4. Measurement, test and evaluation specification

The magnetic field limits specified in table 7 and additional table 8 shall be measured using the antennas defined below (figure 10).

A rectangular 3-dimensional magnetic loop antenna with a common centre point with the following geometrical dimensions shall be used:

1. 5 cm x 5 cm (X-direction)
2. 5 cm x 15 cm (Y- and Z- direction). The longest arm is always in X-direction.

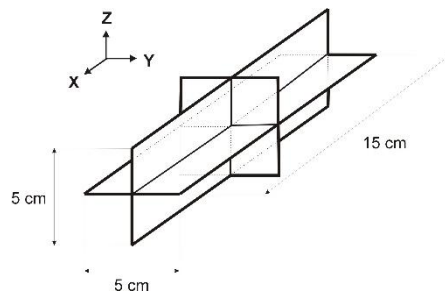

Figure 10: Loop antenna

The following table shall be used to define the mounting position of the measurement antennas MA for the frequency range considered.

Table 9

	<b>Y1 (tolerances) [mm]</b>	<b>Z1 (tolerances) [mm]</b>
<b>MA centre position</b> (10 kHz to 1.3 MHz)	96 (-3; +3)	73 (-5; +5)

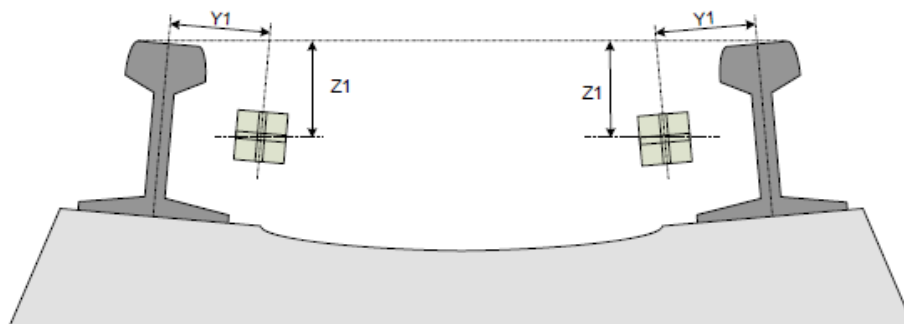

Figure 11: Position of the measurement antenna (internal between the rails)

EN 50592:2016 provides presumption of conformity to this requirement.

### 3.2.2. Conducted interference

The compatibility requirements specified in the following section shall apply for 1435 mm, 1600 mm, 1520 mm, 1524 mm and 1668 mm track gauge network.

#### 3.2.2.1. Vehicle impedance

For AC systems the absolute value of the minimum input impedance ( $|Z|$ ) of the influencing unit shall be as follows:

## INTERFACES BETWEEN CONTROL-COMMAND AND SIGNALLING TRACKSIDE AND OTHER SUBSYSTEMS

*Table 10*

Applicable for Track Circuit Bands with frequency $f$	Supply voltage	Impedance $ Z(f) $
$f \leq 300$ Hz	15 kV AC	$7 \text{ mH} \cdot 2\pi f$
	25 kV AC	$10 \text{ mH} \cdot 2\pi f$

The input impedance of the influencing unit is defined by the input impedance of the main transformer alone as a passive component (e.g. all traction and auxiliary windings of main transformers in short circuit, excluding secondary filter windings) or the input impedance of the passive input filter for architectures without a passive transformer (e.g. multi-level converter).

If the input impedance based on passive components is not sufficient to meet the impedance requirements, the verification can be done including active control for increasing the input impedance.

For AC systems the maximum input capacitance ( $C_{in}$ ), including roof cables and parasitic input capacitances of transformers, between pantograph and wheels of the influencing unit shall be as follows:

*Table 11*

Applicable for Track Circuit Bands with frequency $f$	Supply voltage	$C_{in}$
$4.5 \text{ kHz} \leq f \leq 6.5 \text{ kHz}$ $9 \text{ kHz} \leq f \leq 17 \text{ kHz}$	15 kV AC	200 nF
$1.5 \text{ kHz} \leq f \leq 17 \text{ kHz}$	25 kV AC	200 nF

Resulting capacitances of damping devices shall not be included.

For DC systems, the minimum input impedance  $Z = |Z|e^{j\alpha}$  for an Influencing Unit shall be:

*Table 12*

		1500 V DC	3000 V DC
$1.5 \text{ kHz} \leq f \leq 3 \text{ kHz}$	$ Z(f) $ Phase	$10 \Omega \cdot f [\text{kHz}] / 1.8$ kHz $0 \leq \alpha \leq 90^\circ$	$20 \Omega \cdot f [\text{kHz}] / 1.8$ kHz $0 \leq \alpha \leq 90^\circ$

Note: For frequencies above 3kHz, values for minimum impedance are not yet defined.

For DC the input impedance of the influencing unit is defined by the input impedance of the passive input filter.

If the input impedance based on passive components is not sufficient to meet the impedance requirements, the verification can be done including active control for increasing the input impedance.

**INTERFACES BETWEEN CONTROL-COMMAND AND SIGNALLING TRACKSIDE AND OTHER SUBSYSTEMS**

Explanation:

In train detection systems, to prevent interferences from harmonics generated in the traction system and to prevent (in case of track circuits) cross-over effect through the catenary system from one track to another, a sufficiently high impedance of the train is necessary.

3.2.2.2. *Intentionally deleted*

3.2.2.3. *Traction current at fundamental power supply frequency*

There is no need for harmonised requirements related to train detection.

3.2.2.4. *25 kV AC, 50 Hz Electromagnetic interference limits for traction current*

The subsequent figure illustrates the compatibility limits for interference current emissions from rolling stock (per influencing unit):

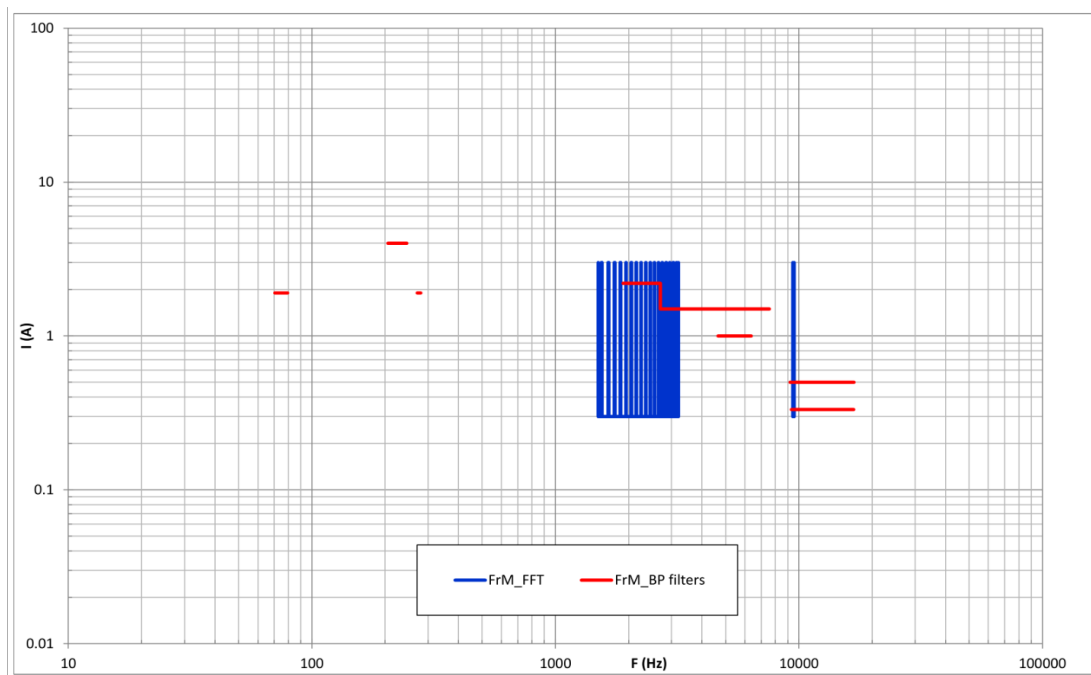

Figure 12: Frequency Management 25kV AC 50 Hz traction

Two types of limits have been defined according to the two methods of evaluation to be used (FFT and band pass filters).

The limits and associated parameters for the evaluation of rolling stock emissions are provided in the following table:

Table 13

**INTERFACES BETWEEN CONTROL-COMMAND AND SIGNALLING TRACKSIDE AND OTHER SUBSYSTEMS**

Band	Frequency range	Interference current limit [rms value]	Evaluation method	Evaluation parameters
A1	70.5 – 79.5 Hz	1,9 A	Band-Pass Filter	<ul style="list-style-type: none"> <li>BP filter characteristics Centre frequencies range: 73, 75, 77Hz 3dB-Bandwidth: 5 Hz Butterworth, order 2*4</li> <li>RMS calculation Integration time: 0.5 s Time overlap: min. 75 %</li> <li>Evaluation criteria Maximum time of exceedance: 1s Minimum time between two exceedances: 2s</li> </ul>
A2	205.5 - 245.4 Hz	4 A	Band-Pass Filter	<ul style="list-style-type: none"> <li>BP filter characteristics Centre frequencies: 208.75, 225.45, 242.15 Hz 3dB-Bandwidth: 6,5Hz Butterworth, 6th order (2 x 3rd order)</li> <li>RMS calculation: Integration time: 0,5s Time overlap: min. 50%</li> <li>Evaluation criteria Maximum time of exceedance: 0,2s Minimum time between two exceedances: 2s</li> </ul>
A3	270.5 – 279.5 Hz	1,9A	Band Pass Filter	<ul style="list-style-type: none"> <li>BP filter characteristics Centre frequencies range: 273, 275, 277 Hz 3dB-Bandwidth: 5 Hz Butterworth, order 2*4</li> <li>RMS calculation Integration time: 0.5 s Time overlap: min. 75 %</li> <li>Evaluation criteria Maximum time of exceedance: 1s Minimum time between two exceedances: 2s</li> </ul>
A4	1500 – 3200 Hz	0,3A (except in bands here below)  3A in bands (30+n)x50±5Hz (n=1,3,5, ...,33)	FFT	<p>Time window 1s, Hanning window, min. 80% overlap</p> <p>Maximum time of exceedance: 0.3s</p>

**INTERFACES BETWEEN CONTROL-COMMAND AND SIGNALLING TRACKSIDE AND OTHER SUBSYSTEMS**

Band	Frequency range	Interference current limit [rms value]	Evaluation method	Evaluation parameters
A5	1900 - 2700 Hz	2,2 A	Band-Pass Filter	<ul style="list-style-type: none"> <li>• BP filter characteristics Centre frequencies: 2100, 2500 Hz 3dB-Bandwidth: 400Hz Chebyshev, BP ripple 0.01dB, 10th order (2 x 5th order)</li> <li>• RMS calculation Integration time: 1s Time overlap: min. 90 %</li> <li>▪ Evaluation criteria Maximum time of exceedance: 1s Minimum time between two exceedances: 1,5s</li> </ul>
A6	2700 - 5100 Hz	1,5 A	Band-Pass Filter	<ul style="list-style-type: none"> <li>• BP filter characteristics Centre frequencies: 2900, 3300, 3700, 4100, 4500, 4900 Hz 3dB-Bandwidth: 400Hz Chebyshev, BP ripple 0.01dB, 10th order (2 x 5th order)</li> <li>• RMS calculation Integration time: 1s Time overlap: min. 90 %</li> <li>▪ Evaluation criteria Maximum time of exceedance: 1s Minimum time between two exceedances: 1,5s</li> </ul>
A7	3450 - 7550 Hz	1,5 A	Band-Pass Filter	<ul style="list-style-type: none"> <li>• BP filter characteristics Centre frequencies: 3750, 4250, 4750, 5250, 5750, 6250, 6750, 7250 Hz 3dB-Bandwidth: 600Hz Chebyshev, BP ripple 0.01dB, 10th order (2 x 5th order)</li> <li>• RMS calculation Integration time: 1s Time overlap: min. 90 %</li> <li>▪ Evaluation criteria Maximum time of exceedance: 1s Minimum time between two exceedances: 1,5s</li> </ul>

## INTERFACES BETWEEN CONTROL-COMMAND AND SIGNALLING TRACKSIDE AND OTHER SUBSYSTEMS

Band	Frequency range	Interference current limit [rms value]	Evaluation method	Evaluation parameters
A8	4650 - 6360 Hz	1 A	Band-Pass Filter	<ul style="list-style-type: none"> <li>• BP filter characteristics Centre frequencies: 4750, 5250, 5750, 6250 Hz 3dB-Bandwidths: 200, 206, 214, 220 Hz Butterworth, 6th order (2 x 3rd order)</li> <li>• RMS calculation Integration time: 40ms Time overlap: min. 50 %</li> <li>▪ Evaluation criteria Maximum time of exceedance: 40ms Minimum time between two exceedances: 80ms</li> </ul>
A9	9436 - 9564 Hz	0,3 A	FFT	<ul style="list-style-type: none"> <li>Time window 1s, Hanning window, min. 80% overlap</li> <li>Maximum time of exceedance: 0.3s</li> </ul>
A10	9200 - 16800 Hz	0,5 A	Band-Pass Filter	<ul style="list-style-type: none"> <li>• BP filter characteristics Centre frequencies: 9500, 10500, 11500, 12500, 13500, 14500, 15500, 16500 Hz 3dB-Bandwidth: 600Hz Chebyshev, BP ripple 0.01dB, 10th order (2 x 5th order)</li> <li>• RMS calculation Integration time: 1s Time overlap: min. 90 %</li> <li>▪ Evaluation criteria Maximum time of exceedance: 1s Minimum time between two exceedances: 1,5s</li> </ul>
A11	9320 - 16755 Hz	0,33 A	Band-Pass Filter	<ul style="list-style-type: none"> <li>• BP filter characteristics Centre frequencies: 9500, 10500, 11500, 12500, 13500, 14500, 15500, 16500 Hz 3dB-Bandwidths: 360, 380, 400, 425, 445, 470, 490, 510 Hz Butterworth, 6th order (2 x 3rd order)</li> <li>• RMS calculation Integration time: 40ms Time overlap: min. 50 %</li> <li>▪ Evaluation criteria Maximum time of exceedance: 40ms Minimum time between two exceedances: 80ms</li> </ul>

The contribution of substations is included in the margin taken into account in the limits of frequency management.

**INTERFACES BETWEEN CONTROL-COMMAND AND SIGNALLING TRACKSIDE AND OTHER SUBSYSTEMS**

Explanation:

The harmonics in the traction current in the rails can interfere with the operation of train detection systems.

*3.2.2.5. 15kV AC, 16,7Hz Electromagnetic interference limits for traction current*

The subsequent figure illustrates the compatibility limits for interference current emissions from rolling stock (per influencing unit):

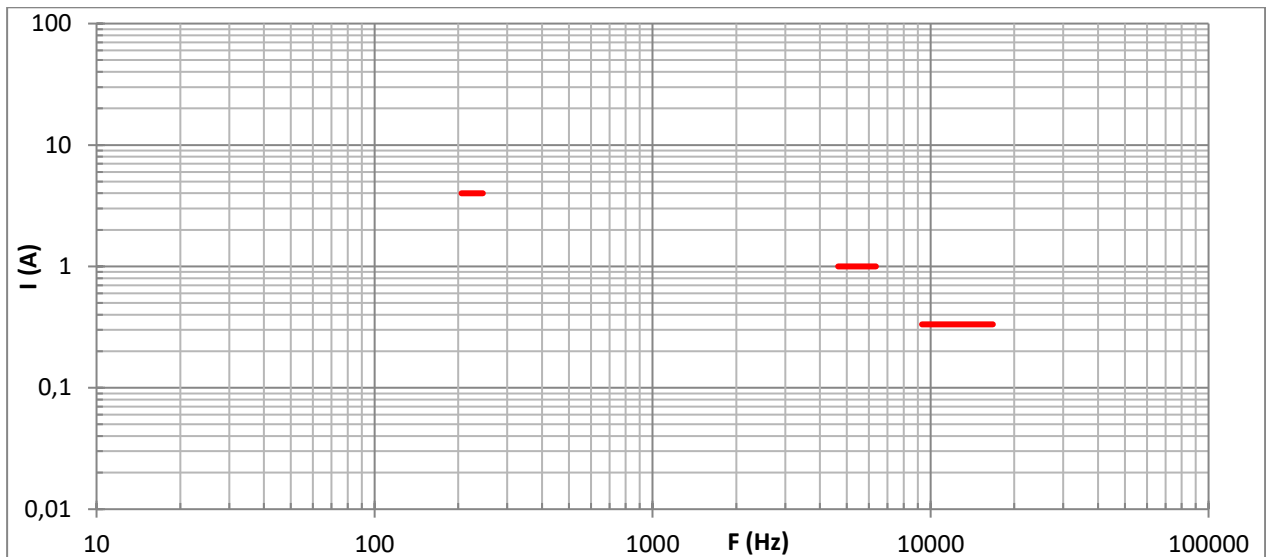

*Figure 13: Frequency Management 15kV AC 16,7 Hz traction*

The limits and associated parameters for the evaluation of rolling stock emissions are provided in the following table:

*Table 14*

Band	Frequency range	Interference current limit [rms value]	Evaluation method	Evaluation parameters
B1	205.5 - 245.4 Hz	4 A	Band-Pass Filter	<ul style="list-style-type: none"> <li>BP filter characteristics Centre frequencies: 208.75, 225.45, 242.15 Hz 3dB-Bandwidth: 6,5Hz Butterworth, 6th order (2 x 3rd order)</li> <li>RMS calculation Integration time: 0,5s Time overlap: min. 50%</li> <li>Evaluation criteria Maximum time of exceedance: 0,2s Minimum time between two exceedances: 2s</li> </ul>

## INTERFACES BETWEEN CONTROL-COMMAND AND SIGNALLING TRACKSIDE AND OTHER SUBSYSTEMS

Band	Frequency range	Interference current limit [rms value]	Evaluation method	Evaluation parameters
B2	4650 - 6360 Hz	1 A	Band-Pass Filter	<ul style="list-style-type: none"> <li>• BP filter characteristics Centre frequencies: 4750, 5250, 5750, 6250 Hz 3dB-Bandwidths: 200, 206, 214, 220 Hz Butterworth, 6th order (2 x 3rd order)</li> <li>• RMS calculation Integration time: 40ms Time overlap: min. 50 %</li> <li>▪ Evaluation criteria Maximum time of exceedance: 40ms Minimum time between two exceedances: 80ms</li> </ul>
B3	9320 - 16755 Hz	0,33 A	Band-Pass Filter	<ul style="list-style-type: none"> <li>• BP filter characteristics Centre frequencies: 9500, 10500, 11500, 12500, 13500, 14500, 15500, 16500 Hz 3dB-Bandwidths: 360, 380, 400, 425, 445, 470, 490, 510 Hz Butterworth, 6th order (2 x 3rd order)</li> <li>• RMS calculation Integration time: 40ms Time overlap: min. 50 %</li> <li>▪ Evaluation criteria Maximum time of exceedance: 40ms Minimum time between two exceedances: 80ms</li> </ul>

The contribution of substations is included in the margin taken into account in the limits of frequency management.

Explanation:

The harmonics in the traction current in the rails can interfere with the operation of train detection systems.

### 3.2.2.6. DC (3kV, 1.5kV) Electromagnetic interference limits for traction current

The subsequent figure illustrates the compatibility limits for interference current emissions measured on rolling stock per influencing unit including substation contribution:

**INTERFACES BETWEEN CONTROL-COMMAND AND SIGNALLING TRACKSIDE AND OTHER SUBSYSTEMS**

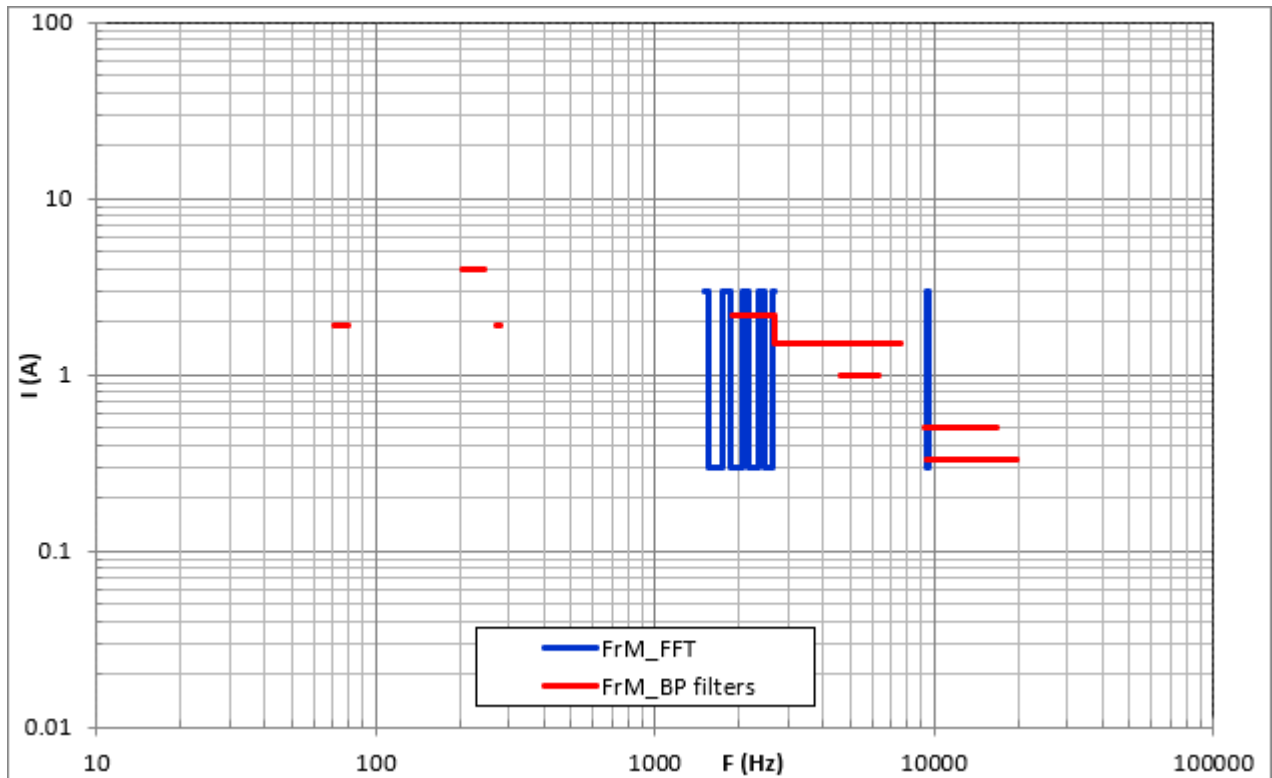

Figure 14: Frequency Management DC traction

Two types of limits have been defined according to the two methods of evaluation to be used (FFT and band pass filters).

The limits and associated parameters for the evaluation of rolling stock emissions are provided in the following table:

Table 15

Band	Frequency range	Interference current limit [rms value]	Evaluation method	Evaluation parameters
C1	70.5 – 79.5 Hz	1,9 A	Band-Pass Filter	<ul style="list-style-type: none"> <li>• BP filter characteristics Centre frequencies: 73, 75, 77 Hz 3dB-Bandwidth: 5 Hz Butterworth, order 2*4</li> <li>• RMS calculation Integration time: 0.5 s Time overlap: min 75 %</li> <li>▪ Evaluation criteria Maximum time of exceedance: 1s Minimum time between two exceedances: 2s</li> </ul>

**INTERFACES BETWEEN CONTROL-COMMAND AND SIGNALLING TRACKSIDE AND OTHER SUBSYSTEMS**

Band	Frequency range	Interference current limit [rms value]	Evaluation method	Evaluation parameters
C2	205.5 - 245.4 Hz	4 A	Band-Pass Filter	<ul style="list-style-type: none"> <li>• BP filter characteristics Centre frequencies: 208.75, 225.45, 242.15 Hz 3dB-Bandwidth: 6,5Hz Butterworth, 6th order (2 x 3rd order)</li> <li>• RMS calculation Integration time: 0,5s Time overlap: min. 50%</li> <li>▪ Evaluation criteria Maximum time of exceedance:0,2s Minimum time between two exceedances: 2s</li> </ul>
C3	270.5 – 279.5 Hz	1,9A	Band-Pass Filter	<ul style="list-style-type: none"> <li>• BP filter characteristics Centre frequencies: 273, 275, 277 Hz 3dB-Bandwidth: 5 Hz Butterworth, order 2*4</li> <li>• RMS calculation: Integration time: 0.5 s Time overlap: min. 75 %</li> <li>▪ Evaluation criteria</li> <li>▪ Maximum time of exceedance: 1s Minimum time between two exceedances: 2s</li> </ul>
C4	1500 - 2700 Hz	0,3A (except in bands here below) 3A in bands 6xnx50±55Hz (n=5,6,7,8,9)	FFT	Time window 1s, Hanning window, min. 80% overlap Maximum time of exceedance: 0.3s
C5	1900 - 2700 Hz	2,2 A	Band-Pass Filter	<ul style="list-style-type: none"> <li>• BP filter characteristics Centre frequencies: 2100, 2500 Hz 3dB-Bandwidth: 400Hz BP ripple 0.01dB, 10th order (2 x 5th order)</li> <li>• RMS calculation Integration time: 1s Time overlap: min. 90 %</li> <li>▪ Evaluation criteria Maximum time of exceedance: 1s Minimum time between two exceedances: 1,5s</li> </ul>

**INTERFACES BETWEEN CONTROL-COMMAND AND SIGNALLING TRACKSIDE AND OTHER SUBSYSTEMS**

Band	Frequency range	Interference current limit [rms value]	Evaluation method	Evaluation parameters
C6	2700 - 5100 Hz	1,5 A	Band-Pass Filter	<ul style="list-style-type: none"> <li>• BP filter characteristics Centre frequencies: 2900, 3300, 3700, 4100, 4500, 4900 Hz 3dB-Bandwidth: 400Hz Chebyshev, BP ripple 0.01dB, 10th order (2 x 5th order)</li> <li>• RMS calculation Integration time: 1s Time overlap: min. 90 %</li> <li>▪ Evaluation criteria Maximum time of exceedance: 1s Minimum time between two exceedances: 1,5s</li> </ul>
C7	3450 - 7550 Hz	1,5 A	Band-Pass Filter	<ul style="list-style-type: none"> <li>• BP filter characteristics Centre frequencies: 3750, 4250, 4750, 5250, 5750, 6250, 6750, 7250 Hz 3dB-Bandwidth: 600Hz Chebyshev, BP ripple 0.01dB, 10th order (2 x 5th order)</li> <li>• RMS calculation Integration time: 1s Time overlap: min. 90 %</li> <li>▪ Evaluation criteria Maximum time of exceedance: 1s Minimum time between two exceedances: 1,5s</li> </ul>
C8	4650 - 6360 Hz	1 A	Band-Pass Filter	<ul style="list-style-type: none"> <li>• BP filter characteristics Centre frequencies: 4750, 5250, 5750, 6250 Hz 3dB-Bandwidths: 200, 206, 214, 220 Hz Butterworth, 6th order (2 x 3rd order)</li> <li>• RMS calculation Integration time: 40ms Time overlap: min. 50 %</li> <li>▪ Evaluation criteria Maximum time of exceedance: 40ms Minimum time between two exceedances: 80ms</li> </ul>
C9	9436 - 9564 Hz	0,3 A	FFT	<p>Time window 1s, Hanning window, min. 80% overlap</p> <p>Maximum time of exceedance: 0.3s</p>

## INTERFACES BETWEEN CONTROL-COMMAND AND SIGNALLING TRACKSIDE AND OTHER SUBSYSTEMS

Band	Frequency range	Interference current limit [rms value]	Evaluation method	Evaluation parameters
C10	9200 - 16800 Hz	0,5 A	Band-Pass Filter	<ul style="list-style-type: none"> <li>• BP filter characteristics Centre frequencies : 9500, 10500, 11500, 12500, 13500, 14500, 15500, 16500 Hz 3dB-Bandwidth: 600Hz Chebyshev, BP ripple 0.01dB, 10th order (2 x 5th order)</li> <li>• RMS calculation Integration time: 1s Time overlap: min. 90 %</li> <li>▪ Evaluation criteria Maximum time of exceedance: 1s Minimum time between two exceedances: 1,5s</li> </ul>
C11	9320 - 19755 Hz	0,33 A	Band-Pass Filter	<ul style="list-style-type: none"> <li>• BP filter characteristics Centre frequencies: 9500, 10500, 11500, 12500, 13500, 14500, 15500, 16500, 17500, 18500, 19500 Hz 3dB-Bandwidths: 360, 380, 400, 425, 445, 470, 490, 510, 510, 510, 510 Hz Butterworth, 6th order (2 x 3rd order)</li> <li>• RMS calculation Integration time: 40ms Time overlap: min. 50 %</li> <li>▪ Evaluation criteria Maximum time of exceedance: 40ms Minimum time between two exceedances: 80ms</li> </ul>

### Explanation:

The harmonics in the traction current in the rails can interfere with the operation of train detection systems.

### 3.2.2.7. Measurement, test and evaluation specification

Compliance of rolling stock with the frequency management for track circuits shall be demonstrated by measurements on a suitable infrastructure and for all relevant rolling stock configurations and operation points. Such measurements are required once per power supply system. Parameters for evaluation are defined in 3.2.2.4, 3.2.2.5 and 3.2.2.6. During evaluation, especially summation of sources and influence of power supply resonances shall be taken into account properly.

### Note:

EN 50728:2024 provides presumption of conformity to this requirement.

### Explanation:

As for axle counters, a test and evaluation method for the vehicle is necessary to proof conformity with the frequency management.

**INTERFACES BETWEEN CONTROL-COMMAND AND SIGNALLING TRACKSIDE AND OTHER SUBSYSTEMS**

---

**3.2.2.8. Partial Application of the Frequency Management for vehicles**

It is permissible that vehicles are only partly compliant to the Frequency Management as specified in sections 3.2.2.1 to 3.2.2.6. The Notified Body shall provide the information in the technical file referenced in the certificate of verification, to which frequency bands the vehicle is compliant including the limitation of use.

The vehicle shall be compliant with the bands published on the ERA webpage for the area of the use of the vehicle.

Note: The vehicle can be a part of the influencing unit, to which the requirements in sections 3.2.2.1 to 3.2.2.6 apply. In this case, conditions of use for the vehicle need to be specified.

Explanation:

Partial application is necessary as long as there are non TSI compliant train detection systems installed in Member States which are not compatible with the complete Frequency Management for Track Circuits, to which vehicles need to be compliant in addition. Furthermore, infrastructure manager may decide to use TSI compliant track circuits working within selected bands of the Frequency Management ensuring compatibility with the existing vehicle fleet.

**3.2.3. Use of magnetic / eddy current brakes**

Harmonised parameter:

If the vehicle is equipped with magnetic or eddy current brakes, it shall be possible to activate and deactivate them.

Explanation:

The rules for the use of magnetic or eddy current brakes are defined by the infrastructure manager.

**3.3. Design of train detection systems**

This chapter includes aspects only applying to the trackside train detection systems and is informative.

**3.3.1. Wrong Side Failures**

Dealing with wrong side failures is part of the safety verification of the train detection system and is not an evaluation criterion for the vehicle-infrastructure interface addressed in this document.

Explanation:

If vehicles meet all requirements as defined in chapters 3.1 and 3.2, interoperability of the railway system is assured, which is the aim of this document.

Safety against harmful interferences is guaranteed by intrinsic properties of the train detection systems which are out of scope of the interface document.

## INTERFACES BETWEEN CONTROL-COMMAND AND SIGNALLING TRACKSIDE AND OTHER SUBSYSTEMS

### 4. CONFORMITY ASSESSMENT

For the different kinds of train detection systems, the following parameters shall be assessed either for the IC (Interoperability Constituent) certification or at subsystem level:

*Table 16*

Train Detection System	Parameters	Relevant for IC certification	Relevant for application engineering (assessed at subsystem level)
Axel counters	3.1.2.1. Maximum distance between following axles	X (**)	X (*)
	3.1.2.2. Minimum distance between following axles	X	
	3.1.2.3. Minimum distance between first and last axle	X	
	3.1.2.4. Maximum distance between front/rear end of train and first/last axle for trains running exclusively on High Speed lines	X (**)	X (*)
	3.1.2.5. Maximum distance between front/rear end of train and first/last axle for trains running on other lines	X (**)	X (*)
	3.1.3.1. Geometric dimension of the rim width	X	
	3.1.3.2. Minimum wheel diameter	X (***)	X (***)
	3.1.3.3. Geometric dimension of flange thickness	X	
	3.1.3.4. Geometric dimension of the flange height	X	
	3.1.3.5 Metal and inductive components-free space between wheels	X	
	3.1.3.6. Wheel material	X	
Track Circuits	3.2.1. Electromagnetic fields	X	
	3.1.2.1. Maximum distance between following axles		X (*)
	3.1.2.3. Minimum distance between first and last axle		X (*) (**)
	3.1.2.4. Maximum distance between front/rear end of train and first/last axle for trains running exclusively on High Speed lines		X (*)
	3.1.2.5. Maximum distance between front/rear end of train and first/last axle for trains running on other lines		X (*)
Loops (LX)	3.2.2 Conducted Interference		X (*)
	Check if the system does not impose any additional requirements at vehicle side as those specified in than chapter 3.1.7.2 in the interface document	Assessed at subsystem level	
Other train detection systems	Check if the system does not impose any additional requirements at vehicle side as those specified in the interface document (3.1/3.2)	Assessed at subsystem level	

The parameters which are not listed above, are not relevant for the conformity assessment of the trackside train detection system.

Train detection systems , which are part of the Control-Command and Signalling Trackside, shall be designed in such a way that they are able to detect a vehicle or consist under the conditions specified by the parameters in this specification (see scope).

As the specified parameters relate on vehicles, no one by one correspondence exists for each of these parameters on control-command and signalling trackside in any case. By considering the control-command and signalling trackside on subsystem level, compatibility of track-side installation can be shown by different ways.

**INTERFACES BETWEEN CONTROL-COMMAND AND SIGNALLING TRACKSIDE AND OTHER SUBSYSTEMS**

---

The applicant shall demonstrate that the train detection system is implemented in a way that interoperability is guaranteed.

This shall be done by applying one of the modules specified in the TSI CCS chapter 6.3.2.2. All modules for 'EC' Verification require evidence on (and assessment of) design and implementation.

Independently from the chosen module, the applicant for the trackside subsystem shall provide evidence for assessment.

(\*)

The assessment of axle counters or track circuits at subsystem level bases on the following evidence provided by the applicant for subsystem assessment:

- 1) Design evidence on:
  - a. the detection of vehicles with a maximum axle distance (see 3.1.2.1) by axle counters or track circuits integrated in the infrastructure (possible information may be the distance between those axle counters/track circuits) which define the begin and the end of a signalling section)
  - b. the detection of vehicles with a minimum axle distance between first and last axle ( $L - (b1 + b2)$ , see 3.1.2.3) by track circuits integrated in the infrastructure (possible information may be the distance of the electrical joints between adjacent track circuits)
  - c. the detection of vehicles with a maximum distance between the first/last axle and the nose/tail of the vehicle (see 3.1.2.4 and 3.1.2.5) in relation to relevant infrastructure side points by axle counters or track circuits integrated in the infrastructure (possible information may be the distance between relevant infrastructure side point and axle counter/track circuit). Information about the relevant infrastructure side points shall be provided by the applicant.

Note:

The applicant may deviate from the distances relating on a), b) and c) if it can be demonstrated that this will not have a negative impact on safety and interoperability of a vehicle defined according 3.1.2.1, 3.1.2.3, 3.1.2.4 or 3.1.2.5.

- 2) Implementation evidence on / results of tests / on-site measurements on:
  - a. the proof that the conditions and limits of use (including installation rules) of track circuits or the IC axle counter have been fulfilled
  - b. the proof that the track circuits or IC axle counters have been installed according to the requirements and criteria defined in 1) - design evidence.

Note: The applicant may deviate from the distances mentioned in 1) a), b) and c) if it can be demonstrated that this will not have a negative impact on safety and interoperability of the vehicle defined in 3.1.2.1, 3.1.2.3, 3.1.2.4 or 3.1.2.5.

(\*\*)

At IC level, it shall be checked that the installation documentation (e.g. manuals, installation procedures) shall take into account this requirement.

(\*\*\*)

The axle counter shall meet the speed requirements respect to the maximum line speed where it is installed.

A condition for use in the certificate of conformity shall indicate the maximum speed for which the axle counter is validated.

#### **4.1. Interoperability Constituent Axle Counter**

The EC declaration of conformity for axle counter products shall cover all parameters applicable for IC certification of axle counters (see Table 16).

For the frequency management defined in chapter 3.2.1 for the immunity level of axle counter (magnetic field), a margin of at least +9dB inband and +3dB outband shall be observed.

If the architecture of the axle counter product does not allow the declaration of conformity for all parameters applicable for axle counters, the EC declaration for conformity shall explicitly mention these parameters. These parameters have to be checked at subsystem level according to chapter 6.3 of the CCS TSI.

## **5. Non TSI Compliant Train Detection Systems**

### **5.1. Technical characteristics of non TSI compliant train detection systems**

Harmonised parameter:

The requirements to ensure compatibility of vehicles with non TSI compliant train detection systems are either specified as Specific Cases in TSI CCS or specified in an ERA technical document, with the structure and format as specified in Annex B.1

Explanation:

The requirements for non TSI compliant train detection system shall be specified in the same way as for TSI compliant train detection systems, as far as possible. Member States will transfer the requirements for each of their existing non TSI compliant train detection systems into this ERA technical document.

### **5.2. Compliance with non TSI compliant train detection systems**

Harmonised Parameter

Compatibility of a vehicle with non TSI compliant train detection systems is based on compliance with the requirements of technical documents as specified in section 5.1 or with specific cases.

The Notified Body of the assessment of the rolling stock subsystem shall include in his technical file the information about the technical documents and specific cases for which compliance was positively checked.

Explanation:

Member States notify either Technical documents or Specific Cases for the Non TSI compliant axle counters and track circuits.

**INTERFACES BETWEEN CONTROL-COMMAND AND SIGNALLING TRACKSIDE AND OTHER SUBSYSTEMS**

**6. ANNEX A.1 Vehicle metal construction – requirements on the construction**

In the following, “length” refers to the direction in parallel to the track and “width” refers to the direction orthogonal to the track.

The description of this parameter is done with reference to the figure below:

- a: section (distance) between the inner axles of two adjacent bogies or wheel sets
- b: section (distance) between the first (respectively the last) axle and the nearest end of the vehicle (excluding the coupling systems)
- c: distance between top of rail and vehicle floor (bottom side)
- d: distance between adjacent conducting cross connections / length of short circuit rings (electrically conducting loops) formed by frame beams and conducting cross connections
- e: distance of adjacent longitudinal frame beams
- f, g, h: dimensions of electrically connected conducting constituents (X)
- i, k: dimensions of short circuit rings (electrically conducting loops) formed by electrically connected conducting constituents (X)
- o: distance between adjacent short circuit rings
- p: distance between short circuit rings and adjacent wheel sets
- X: conductive constituents mounted below vehicle floor

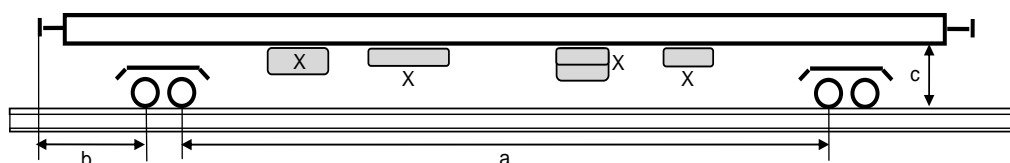

A: Defined distances and areas (the illustrated bogies with two axles are only an example; a bogie can consist of different numbers of axles)

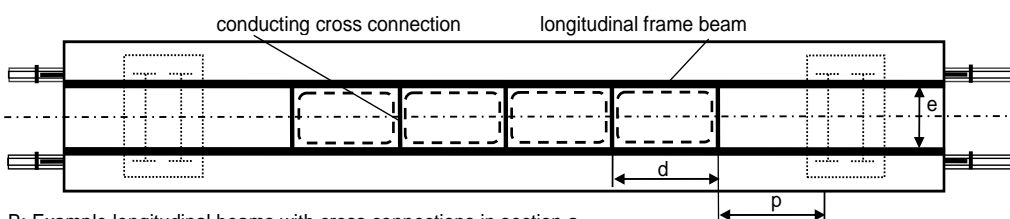

B: Example longitudinal beams with cross connections in section a

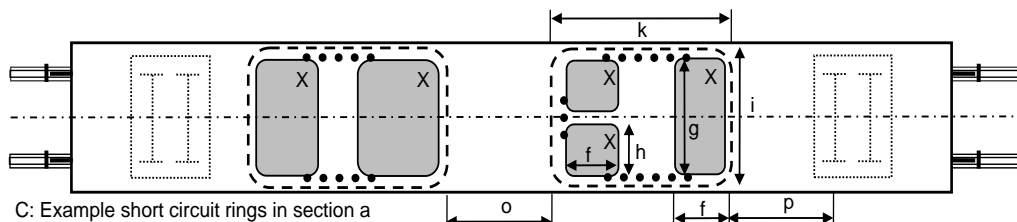

C: Example short circuit rings in section a

- Resulting short circuit ring (electrically conducting loop)
- Principle routing of the cables for the electrical connection of electrically conductive constituents

Figure A1.1: Vehicle layouts

## INTERFACES BETWEEN CONTROL-COMMAND AND SIGNALLING TRACKSIDE AND OTHER SUBSYSTEMS

---

For the scope of this parameter, the vehicle is subdivided in different sections as shown in Figure A1.1A: a central section (a), two outer sections (b) and the sections of the bogies or single wheel sets. The parameter is respected when the design of the vehicle is such that at least one of the conditions 1, 2 or 3 is fulfilled in section (a) and section (b) and condition 4 (or alternatively at least one of the conditions 1, 2 or 3) is fulfilled in the sections of bogies or single wheel sets (in case of vehicles without bogies):

1. The distance (c) between rail level and vehicle floor (bottom side) is less than 1.06 m and the vehicle has a metal floor over its full length (excluding the coupling systems) with a minimum width of 2 m and with a conductivity greater than  $1 \text{ m}/(\Omega \text{ mm}^2)$ .

2. The vehicle has constructive structures at least inside section (a) and (b) consisting of longitudinal frame beams symmetrically on both sides with a minimum distance (e) of 1.0 m. These are electrically connected with conducting cross connections in a distance (d) less than or equal to 3 m to form short circuit rings (electrically conducting loops) as illustrated in Figure A1.1B, showing an example for section (a).

The electrical DC resistance of the resulting short circuit rings is lower than  $1 \Omega$ .

The distance (o) between adjacent short circuit rings does not exceed 3 m. The distance (p) between a short circuit ring and an adjacent wheel set of a bogie does not exceed 3 m, the distance to a single wheel set does not exceed 1.5 m.

The distance between rail level and short circuit rings on the bottom side of vehicle floor is less than 1.06 m.

3. The vehicle has electrically conducting constituents (X) mounted below the floor at least inside section (a) and (b). These are electrically connected to form short circuit rings (electrically conducting loops) as illustrated in Figure A1.1C, showing an example for section (a). The dimensions of the constituents fulfil at least one of the following conditions:

- a) minimum width (g) of 2 m and minimum longitudinal length (f) of 1 m,
- b) minimum width (h) of 1 m and minimum longitudinal length (f) of 1 m on both long sides of the vehicle.

The electrical connection is done in a way that short circuit rings with a length (k) equal or more than 2.5 m but less or equal than 3 m and a minimum width (i) of 2 m result. Figure A1.1C illustrates the principle routing of the cabling.

The conductivity of the conducting constituents is greater than  $1 \text{ m}/(\Omega \text{ mm}^2)$ . The electrical DC resistance of the resulting short circuit rings is lower than  $1 \Omega$ .

The distance (o) between adjacent short circuit rings does not exceed 3 m. The distance (p) between a short circuit ring and an adjacent wheel set of a bogie does not exceed 3 m, the distance to a single wheel set does not exceed 1.5 m.

The distance between rail level and short circuit rings on the bottom side of vehicle floor is less than 1.06 m.

4. Bogies consist of metal parts with a conductivity greater than  $1 \text{ m}/(\Omega \text{ mm}^2)$ . Constructive supporting metal parts of a bogie frame are electrically connected with an electrical DC resistance lower than  $1 \Omega$ . The distance between rail level and the bottom side of the bogie frame is less than 1.06 m.

Alternatively, if these requirements are not fulfilled at least condition 1, 2 or 3 shall be fulfilled in the section of the bogie.

This parameters ensures compatibility with loops.

## 7. ANNEX A.2 Verification of Vehicle metal construction - Change of inductivity of trackside loops

Alternatively to the method defined in Annex A.1 compatibility of a vehicle with loops can be shown by the measurement and evaluation of the change of the inductivity of a reference loop by passing of the vehicle (the definitions below are related on loops, used for level crossing with a track gauge of 1435mm).

### Measurement arrangement

- The reference loop is installed in the form of an “8” (see Figure A.2.1)
- The loop is formed by an insulated copper cable 3 \* 1,5 mm<sup>2</sup> (like H07RN-F) and is located at the rail base between the running rails above the sleepers (wood or concrete sleepers, no steel sleepers). The distance of the cable form the rail shall be 10 – 20mm (see Figure A.2.2).
- The reference loop shall have three turns (windings) including a connection wire of 3,5 m.
- The length of a half-loop is 3.0m +0m/-0.05m
- The distance between both half-loops is 0.1m ± 0,05 m at the middle of the loop (see Figure A.2.1)

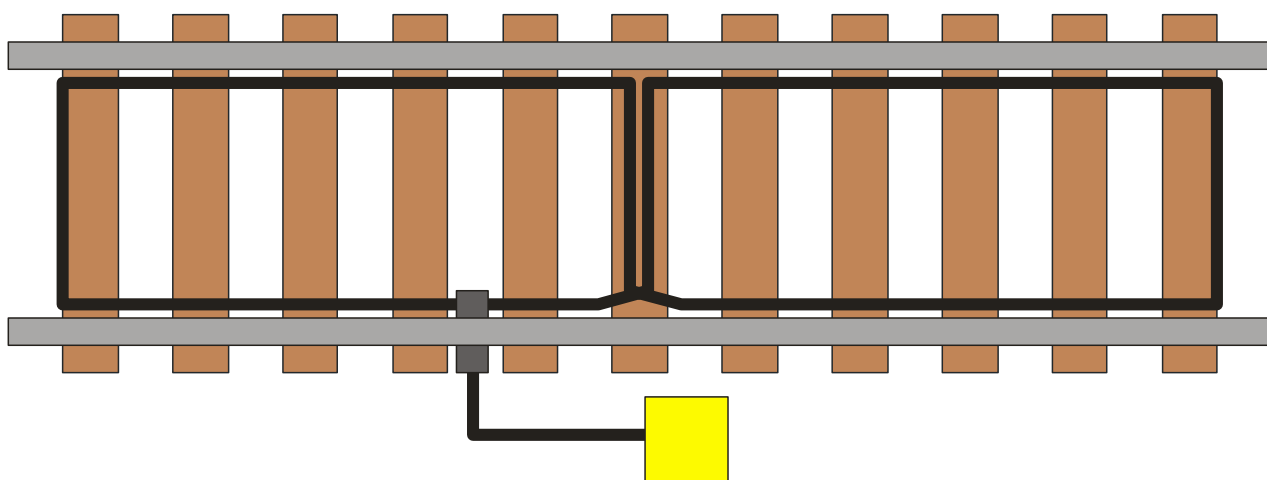

Figure A.2.1.- Reference loop mounted at the track (figure based on a track gauge of 1435 mm).

### Measurement process

- The passing vehicle is electrically passive while passing the reference loop. All electrical equipment/consumers are – as far as possible - switched off.
- The running speed of the vehicle is less than 30 km/h while passing the reference loop (based on the required detection period, defined below)
- Tests shall be carried out twice in both running directions. Tests with the vehicle and without the vehicle shall be carried out in short time distance.

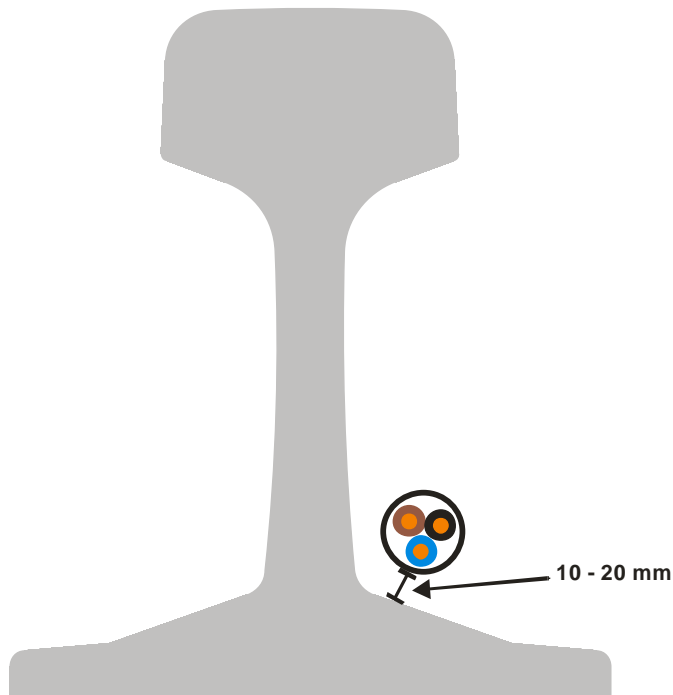

Figure A.2.2.- Mounted cable (the distance between cable and rail shall be inside the tolerance over the whole loop)

### Measurement and evaluation

- The inductivity of the reference loop shall be measured with the passing vehicle and without the vehicle; The relevant parameter is the relative reduction of the inductivity of the loop defined by  $(L_0 - L) / L_0$  in percent, when the vehicle runs over the loop, where:
  - o  $L_0$ : is the inductivity of the loop without vehicle and
  - o  $L$ : is the inductivity of the loop with vehicle.
- The inductivity shall be measured
  - o without the vehicle and
  - o while the vehicle is passing over the loop.
- It is sufficient to perform the measurement at a frequency of 60 kHz only (measurements done at 60 kHz are valid for loops working in frequency ranges from 20 kHz up to 110 kHz).
- The determination of the relative inductivity change shall have an accuracy of 0.1% (concerning only the results of the delta measurement).
- Measurement window (detection period) shall be maximum 10ms (overlap 50%)
- The relative reduction of inductivity of the loop shall be:
  - a) equal or greater than 3.5 % at the beginning of the vehicle (when the first axle is more than 3 m within the loop)
  - b) equal or greater than 0.8 % between the first and the last axle of a vehicle or train
  - c) less than 0.5 % when the vehicle has completely passed the loop.

## 8. ANNEX B.1 ERA Technical Document for Non TSI compliant train detection systems



Annex%20B1%20Tem  
plate%20for%20non%